

STATE OF ILLINOIS  
DEPARTMENT OF TRANSPORTATION

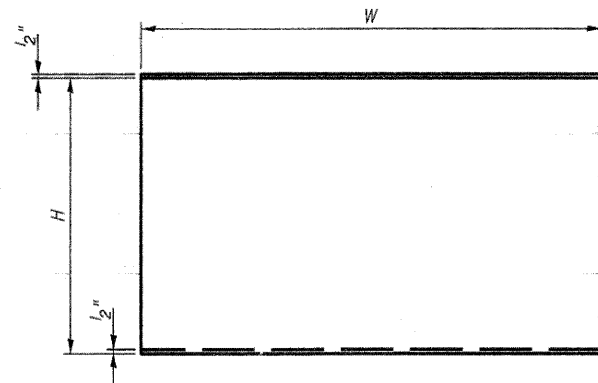

TYPICAL PANEL  
ELEVATION

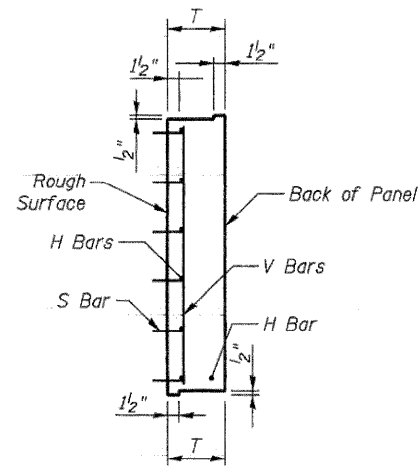

PANEL END VIEW

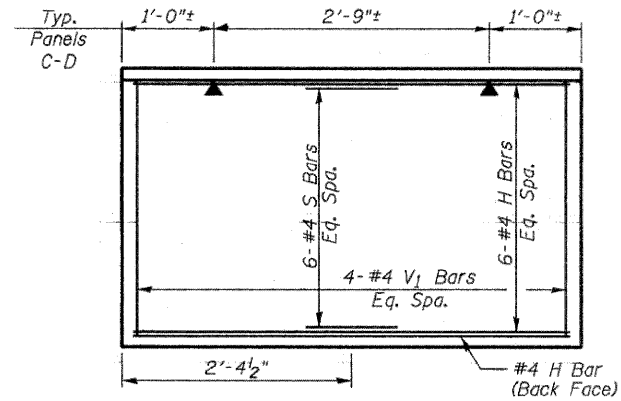

PANEL C REINFORCEMENT

\*Reinforcement Quantities for information only.  
Reinforcement and concrete for panels are  
included in the Pay Item "Retaining Wall (Special)."

\*BILL OF MATERIAL

BAR	NO.	SIZE	LENGTH	SHAPE
H	1045	#4	4'-6"	—
S	879	#4	2'-4"	—
V	468	#4	1'-9"	—
V <sub>1</sub>	196	#4	2'-9"	⌒
Reinforcement Bars			Pound	5,420
Concrete Structures			Cu. Yd.	52

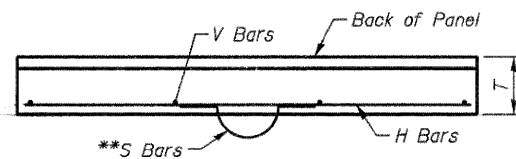

PANEL TOP VIEW

\*\*Embedded Connection Device  
(See Precast Wall Panels Special Provision)

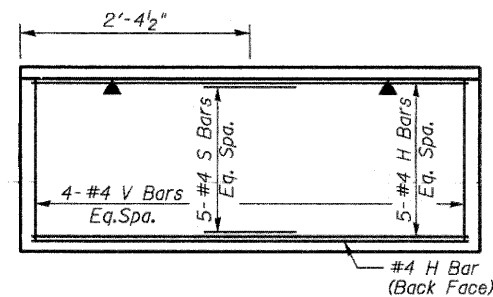

PANEL D REINFORCEMENT

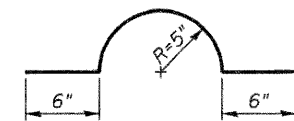

\*\* S BAR

PANEL	H	W	T
C	2'-11 <sup>3</sup> / <sub>4</sub> "	4'-9"	7 <sup>1</sup> / <sub>2</sub> "
D	1'-11 <sup>3</sup> / <sub>4</sub> "	4'-9"	7 <sup>1</sup> / <sub>2</sub> "

PANEL DETAILS  
IL. RTE. 2  
RETAINING WALL B  
STA. 634+70.00 TO STA. 637+05.00

DESIGNED	DFM
CHECKED	DSG
DRAWN	EBS
CHECKED	DFM

SHEET NO. 5 12 SHEETS	F.A.P. RTE.	SECTION	COUNTY	TOTAL SHEETS	SHEET NO.
	742	37 R-3	OGLE	345	105
		SN 071-7002	CONTRACT NO. 84788		
		FED. ROAD DIST. NO. 7	ILLINOIS	FED. AID PROJECT	