

STAGE 11

STA. 628 + 29 - 673 + 00

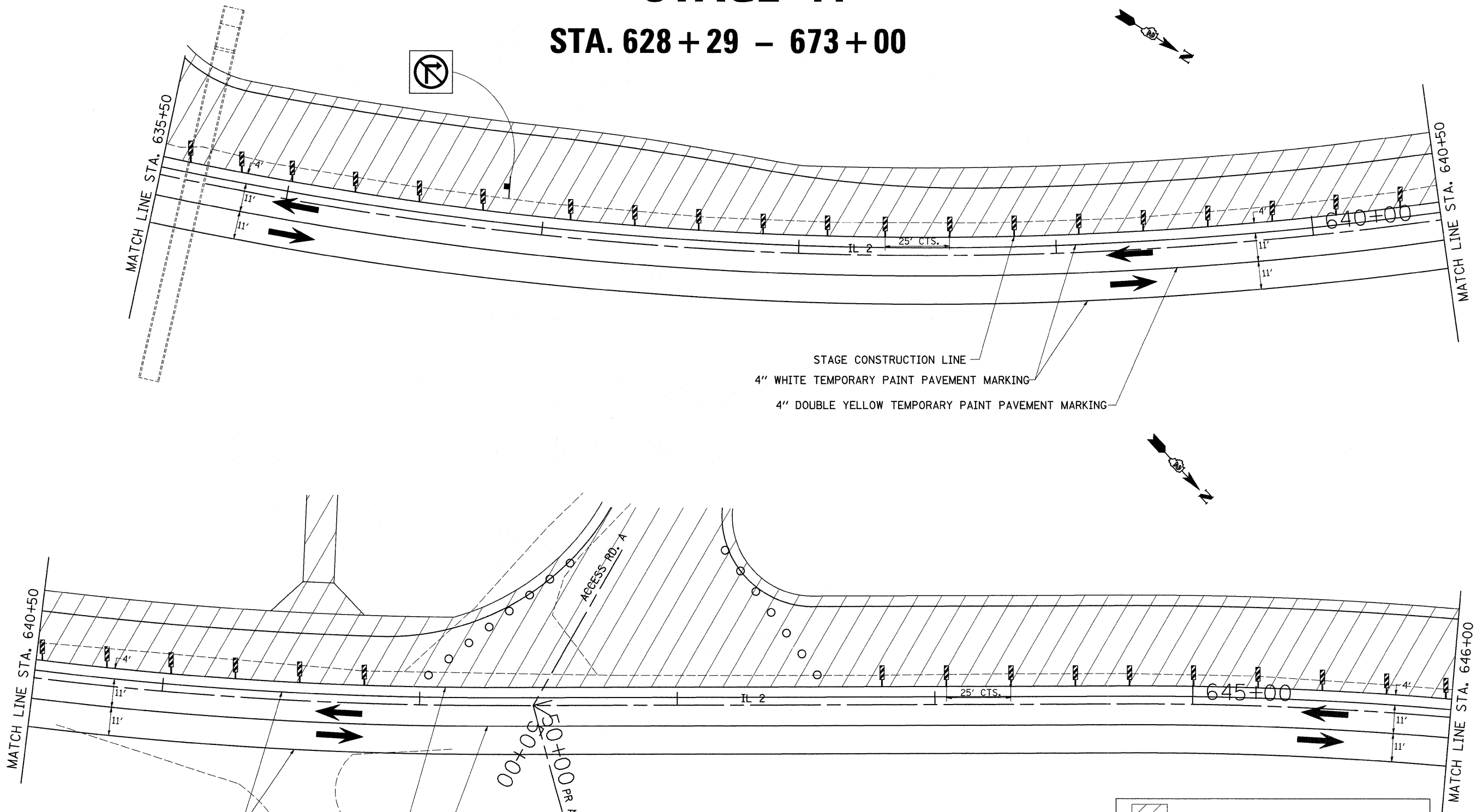

STAGE CONSTRUCTION LINE
 4" WHITE TEMPORARY PAINT PAVEMENT MARKING
 4" DOUBLE YELLOW TEMPORARY PAINT PAVEMENT MARKING

4" WHITE TEMPORARY PAINT PAVEMENT MARKING
 STAGE CONSTRUCTION LINE
 4" DOUBLE YELLOW TEMPORARY PAINT PAVEMENT MARKING

STAGE 11 NOTES

1. USE STANDARD 701331. SEE STANDARDS FOR ADDITIONAL SIGNING AND DEVICES NOT SHOWN IN DETAILS.
2. CLOSE SIDEROADS "BLACKHAWK VISTA" AND "CARTWRIGHT LN." AS SHOWN
3. REMOVAL OF EXISTING PAVEMENT FROM STA. 628+29 TO 673+00 TO STAGE LINE.
4. CONSTRUCT SUB-BASE GRANULAR MATERIAL TYPE A.
5. CONSTRUCT STORM SEWER, INLETS AND COMBINATION CONCRETE CURB & GUTTER.
6. CONSTRUCT PCC PAVEMENT (JOINTED) & PCC SHOULDERS.

	= WORK AREA
	= TYPE III BARRICADE WITH FLASHING LIGHTS
	= SIGN
	= BARRICADE, OR DRUM WITH STEADY BURNING LIGHTS
	= VERTICAL PANEL OR VERTICAL BARRICADE

FILE NAME =	USER NAME = cushmanbw	DESIGNED -	REVISED -
ci:\pw_work\PWIDOT\CUSHMANBW\dms34123\06486stg69.dgn		DRAWN -	REVISED -
PLOT SCALE = 20,0000' / IN.		CHECKED -	REVISED -
PLOT DATE = Fri May 01 07:37:43 2009		DATE -	REVISED -

STATE OF ILLINOIS
 DEPARTMENT OF TRANSPORTATION

STAGE 11

SCALE:	SHEET NO.	OF	SHEETS	STA.	TO STA.	F.A.P. RTE. 742	SECTION 37RS-3	COUNTY OGLE	TOTAL SHEETS 345	SHEET NO. 101
						CONTRACT NO. 84788				
						FED. ROAD DIST. NO. [ILLINOIS] FED. AID PROJECT				

STAGE 11

STA. 628 + 29 - 673 + 00

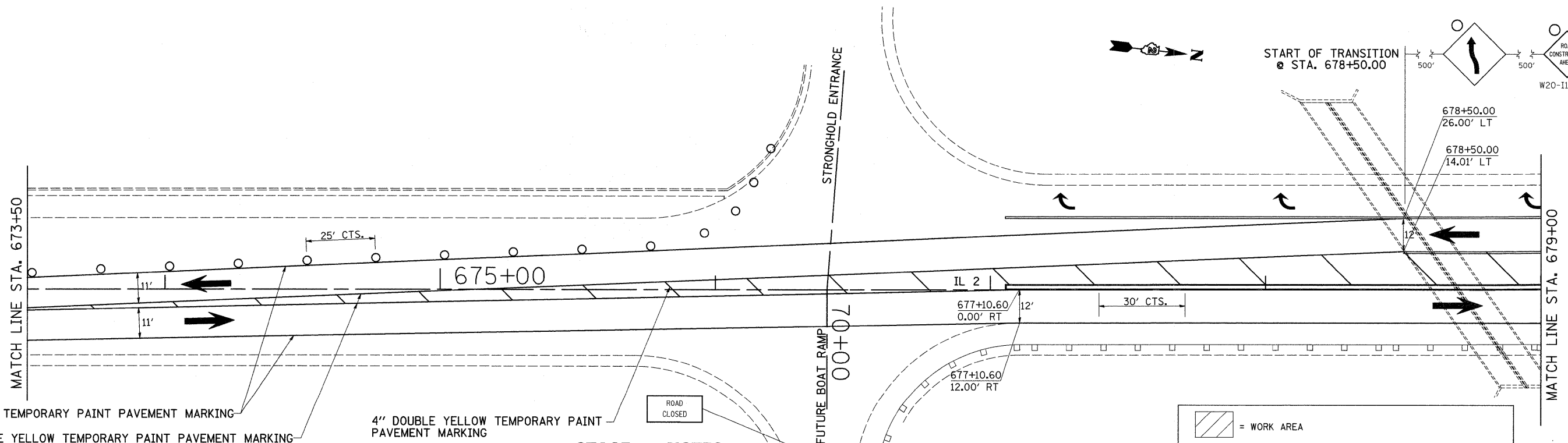
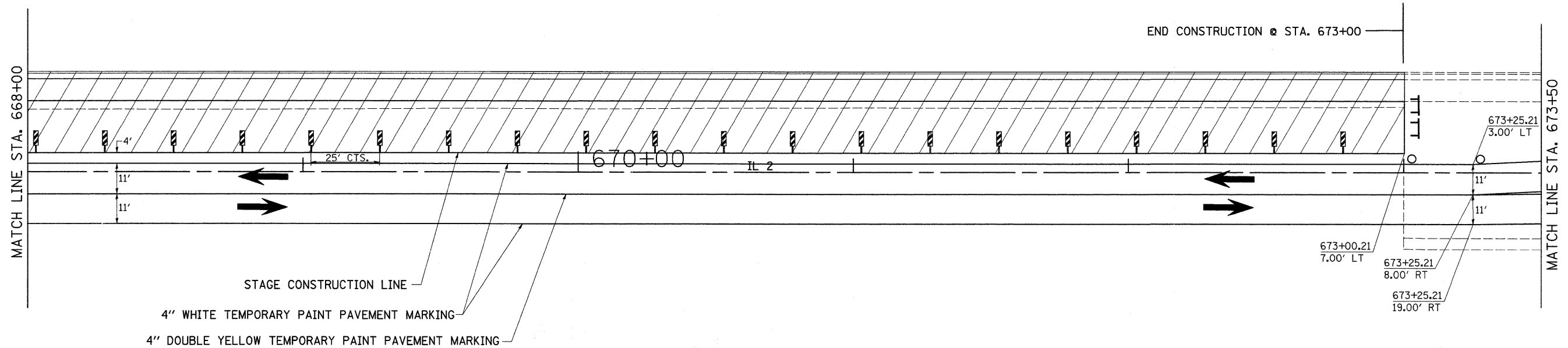

4" WHITE TEMPORARY PAINT PAVEMENT MARKING
4" DOUBLE YELLOW TEMPORARY PAINT PAVEMENT MARKING

4" DOUBLE YELLOW TEMPORARY PAINT PAVEMENT MARKING

STAGE 11 NOTES

1. USE STANDARD 701331. SEE STANDARDS FOR ADDITIONAL SIGNING AND DEVICES NOT SHOWN IN DETAILS.
2. CLOSE SIDEROADS "BLACKHAWK VISTA" AND "CARTWRIGHT LN." AS SHOWN
3. REMOVAL OF EXISTING PAVEMENT FROM STA. 628+29 TO 673+00 TO STAGE LINE.
4. CONSTRUCT SUB-BASE GRANULAR MATERIAL TYPE A.
5. CONSTRUCT STORM SEWER, INLETS AND COMBINATION CONCRETE CURB & GUTTER.
6. CONSTRUCT PCC PAVEMENT (JOINTED) & PCC SHOULDERS.

	= WORK AREA
	= TYPE III BARRICADE WITH FLASHING LIGHTS
	= SIGN
	= BARRICADE, OR DRUM WITH STEADY BURNING LIGHTS
	= VERTICAL PANEL OR VERTICAL BARRICADE

FILE NAME =	USER NAME = cushmanbw	DESIGNED -	REVISED -	STATE OF ILLINOIS DEPARTMENT OF TRANSPORTATION	STAGE 11	F.A.P. RTE. 742	SECTION 37RS-3	COUNTY OGLE	TOTAL SHEETS 345	SHEET NO. 104	
ct:\pwwork\pwidot\CUSHMANBW\dms34123\6486stg69.dgn	PLOT SCALE = 20.0000' / IN.	DRAWN -	REVISED -			SCALE:	SHEET NO. OF SHEETS	STA. TO STA.	FED. ROAD DIST. NO.	ILLINOIS FED. AID PROJECT	CONTRACT NO. 84788
	PLOT DATE = Fri May 01 07:38:20 2009	CHECKED -	REVISED -								
		DATE -	REVISED -								

STAGE 11

STA. 628 + 29 - 673 + 00

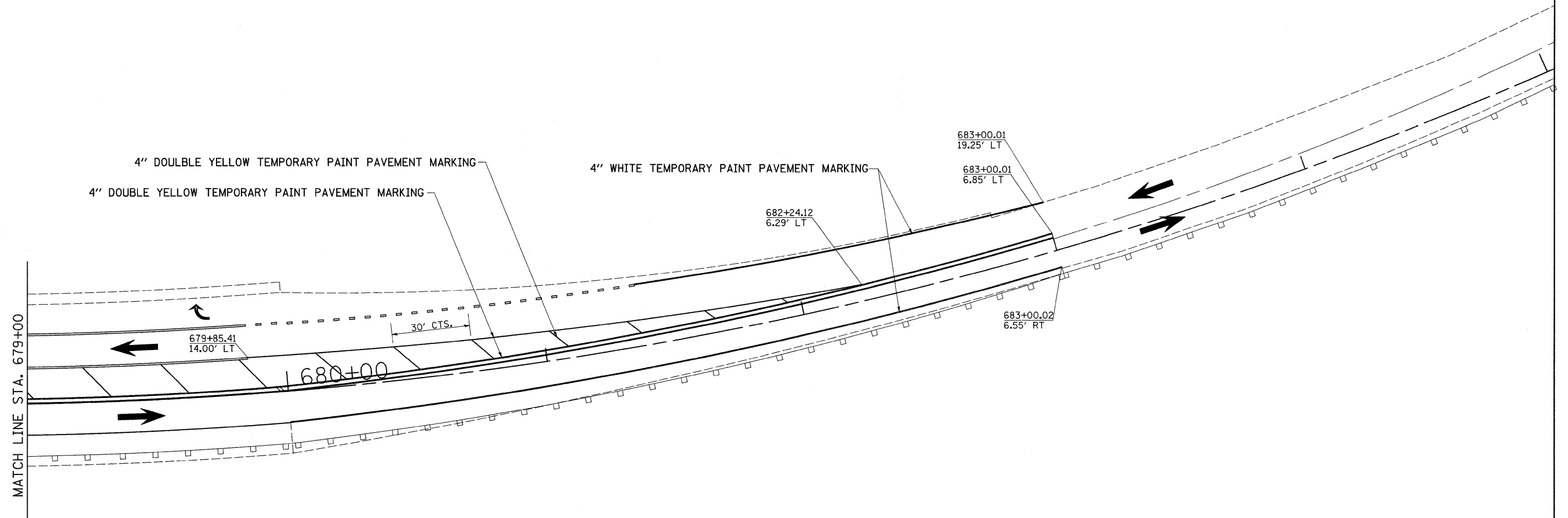

STAGE 11 NOTES

1. USE STANDARD 701331. SEE STANDARDS FOR ADDITIONAL SIGNING AND DEVICES NOT SHOWN IN DETAILS.
2. CLOSE SIDEROADS "BLACKHAWK VISTA" AND "CARTWRIGHT LN." AS SHOWN
3. REMOVAL OF EXISTING PAVEMENT FROM STA. 628+29 TO 673+00 TO STAGE LINE.
4. CONSTRUCT SUB-BASE GRANULAR MATERIAL TYPE A.
5. CONSTRUCT STORM SEWER, INLETS AND COMBINATION CONCRETE CURB & GUTTER.
6. CONSTRUCT PCC PAVEMENT (JOINTED) & PCC SHOULDERS.

	= WORK AREA
	= TYPE III BARRICADE WITH FLASHING LIGHTS
	= SIGN
	= BARRICADE, OR DRUM WITH STEADY BURNING LIGHTS
	= VERTICAL PANEL OR VERTICAL BARRICADE

FILE NAME =	USER NAME = cushmanbw	DESIGNED -	REVISED -	STATE OF ILLINOIS DEPARTMENT OF TRANSPORTATION	STAGE 11	F.A.P. RTE.	SECTION	COUNTY	TOTAL SHEETS	SHEET NO.	
cu:\pw_work\PWIDOT\CUSHMANBW\dms34123\6486stg69.dgn	6486stg69.dgn	DRAWN -	REVISED -			742	37RS-3	OGLE	345	105	
PLOT SCALE = 20.0000' / IN.	CHECKED -	REVISED -				CONTRACT NO. 84788					
PLOT DATE = Fri May 01 07:41:24 2009	DATE -	REVISED -				FED. ROAD DIST. NO. ILLINOIS FED. AID PROJECT					
						SCALE:	SHEET NO.	OF	SHEETS	STA.	TO STA.

STAGE 12

STA. 628 + 29 - 673 + 00

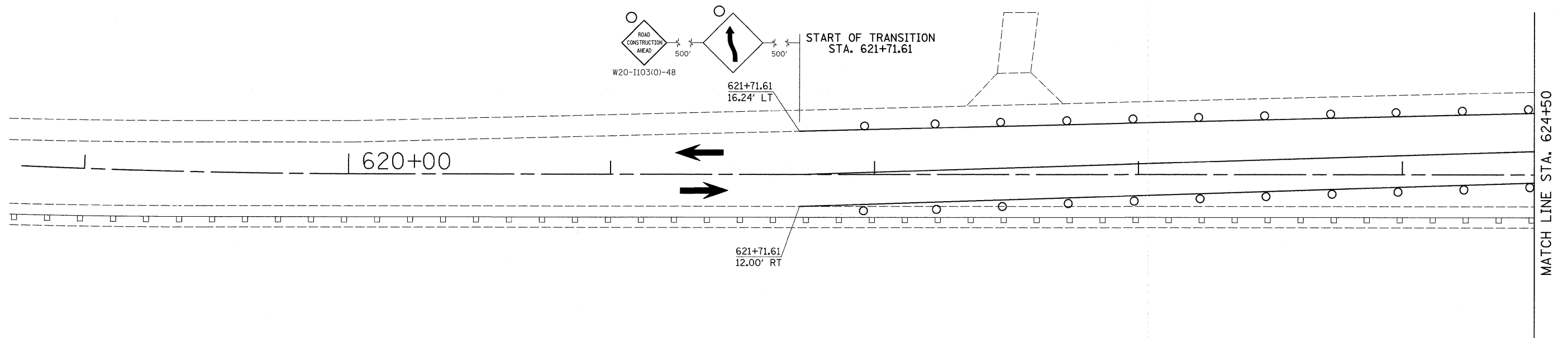

STAGE 12 NOTES

1. USE STANDARD 701331. SEE STANDARDS FOR ADDITIONAL SIGNING AND DEVICES NOT SHOWN IN DETAILS.
2. REMOVAL OF EXISTING PAVEMENT FROM STA. 628+29 TO 673+00 TO STAGE LINE.
3. CONSTRUCT SUB-BASE GRANULAR MATERIAL TYPE A.
4. CONSTRUCT PCC PAVEMENT (JOINTED) & PCC SHOULDERS.
5. COMPLETE DOWNSTREAM END OF CULVERT AT STA. 635+63 AND CONSTRUCT RETAINING WALL B.
6. REMOVE TEMPORARY IMPACT ATTENUATOR FROM STA. 627+00.
7. INSTALL STEEL PLATE BEAM GUARDRAIL, TYPE A, 6' POSTS FROM STA. 627+00 TO 637+08.
8. INSTALL TRAFFIC BARRIER TERMINAL, TYPE 2 AT STA. 637+08.

	= WORK AREA
	= TYPE III BARRICADE WITH FLASHING LIGHTS
	= SIGN
	= BARRICADE, OR DRUM WITH STEADY BURNING LIGHTS
	= VERTICAL PANEL OR VERTICAL BARRICADE

FILE NAME =	USER NAME = cushmanbw	DESIGNED -	REVISED -	STATE OF ILLINOIS DEPARTMENT OF TRANSPORTATION	STAGE 12	F.A.P. RTE.	SECTION	COUNTY	TOTAL SHEETS	SHEET NO.	
ct:\pw_work\PWIDOT\CUSHMANBW\dms34123\6486stg69.dgn	6486stg69.dgn	DRAWN -	REVISED -			742	37RS-3	OGLE	345	106	
PLOT SCALE = 20,0000 ' / IN.	CHECKED -	REVISED -				CONTRACT NO. 84788					
PLOT DATE = Fri May 01 07:40:06 2009	DATE -	REVISED -				SCALE:	SHEET NO.	OF	SHEETS	STA.	TO STA.

STAGE 12

STA. 628+29 - 673+00

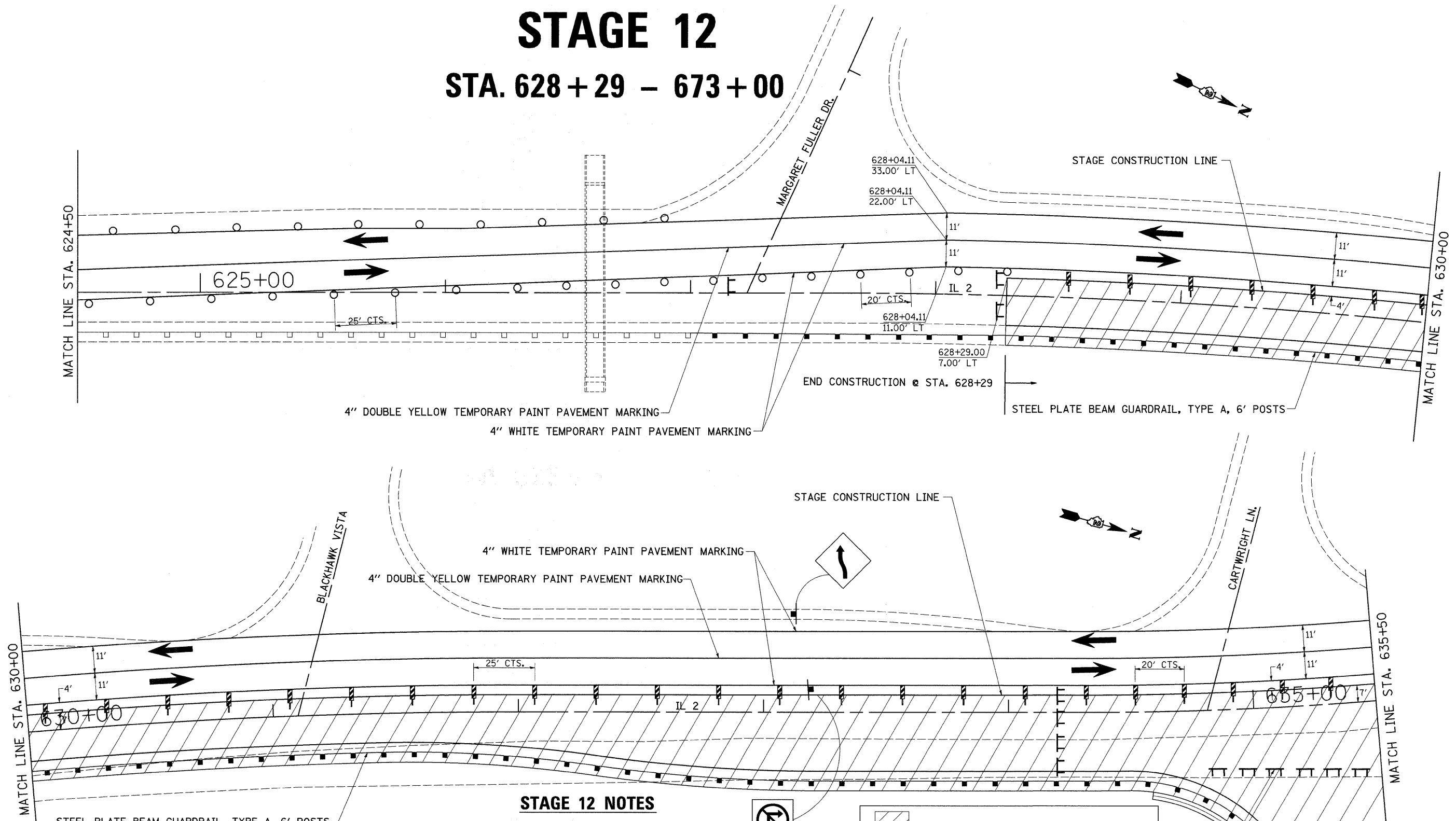

STAGE 12 NOTES

1. USE STANDARD 701331. SEE STANDARDS FOR ADDITIONAL SIGNING AND DEVICES NOT SHOWN IN DETAILS.
2. REMOVAL OF EXISTING PAVEMENT FROM STA. 628+29 TO 673+00 TO STAGE LINE.
3. CONSTRUCT SUB-BASE GRANULAR MATERIAL TYPE A.
4. CONSTRUCT PCC PAVEMENT (JOINTED) & PCC SHOULDERS.
5. COMPLETE DOWNSTREAM END OF CULVERT AT STA. 635+63 AND CONSTRUCT RETAINING WALL B.
6. REMOVE TEMPORARY IMPACT ATTENUATOR FROM STA. 627+00.
7. INSTALL STEEL PLATE BEAM GUARDRAIL, TYPE A, 6' POSTS FROM STA. 627+00 TO 637+08.
8. INSTALL TRAFFIC BARRIER TERMINAL, TYPE 2 AT STA. 637+08.

	= WORK AREA
	= TYPE III BARRICADE WITH FLASHING LIGHTS
	= SIGN
	= BARRICADE, OR DRUM WITH STEADY BURNING LIGHTS
	= VERTICAL PANEL OR VERTICAL BARRICADE

FILE NAME =	USER NAME = ouahmanbw	DESIGNED -	REVISED -	STATE OF ILLINOIS DEPARTMENT OF TRANSPORTATION	STAGE 12	F.A.P. RTE.	SECTION	COUNTY	TOTAL SHEETS	SHEET NO.	
cs:\pw_work\PWIDOT\CUSHMANBW\dms34123\dms6486stg69.dgn	PL0T SCALE = 20,0000' / IN.	DRAWN -	REVISED -			742	37RS-3	OGLE	345	107	
PL0T DATE = Fri May 01 07:38:43 2009	DATE -	CHECKED -	REVISED -			CONTRACT NO. 84788					
						SCALE:		SHEET NO. OF SHEETS STA. TO STA.		FED. ROAD DIST. NO. ILLINOIS FED. AID PROJECT	

STAGE 12

STA. 628+29 - 673+00

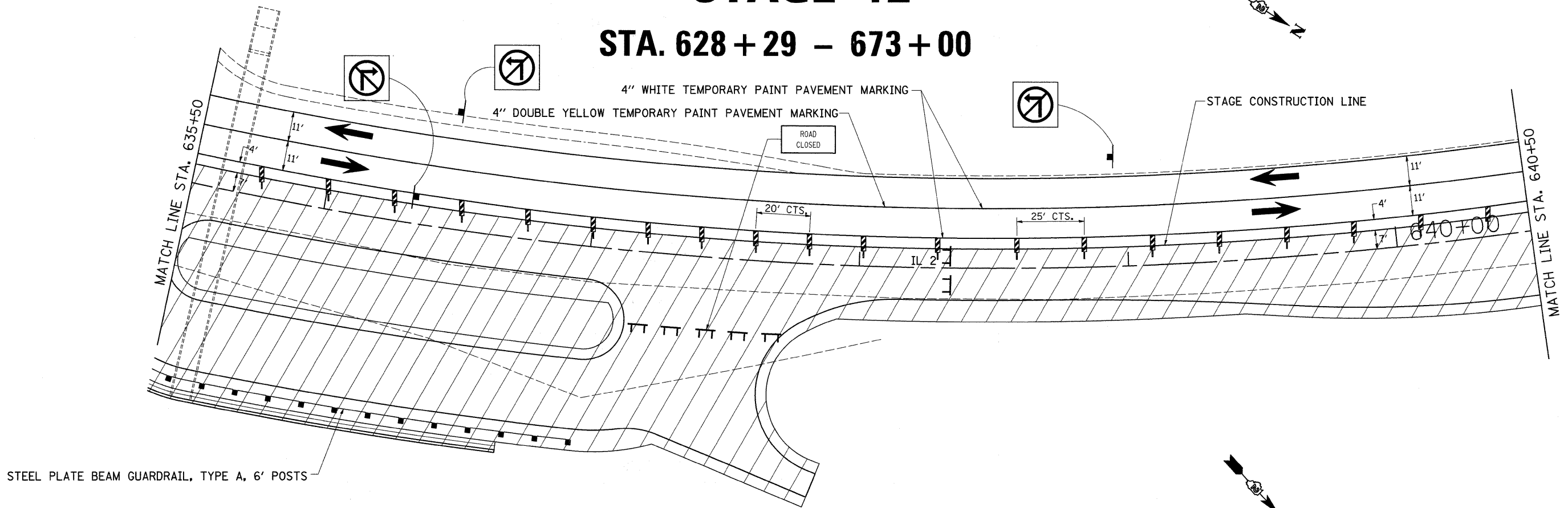

STEEL PLATE BEAM GUARDRAIL, TYPE A, 6' POSTS

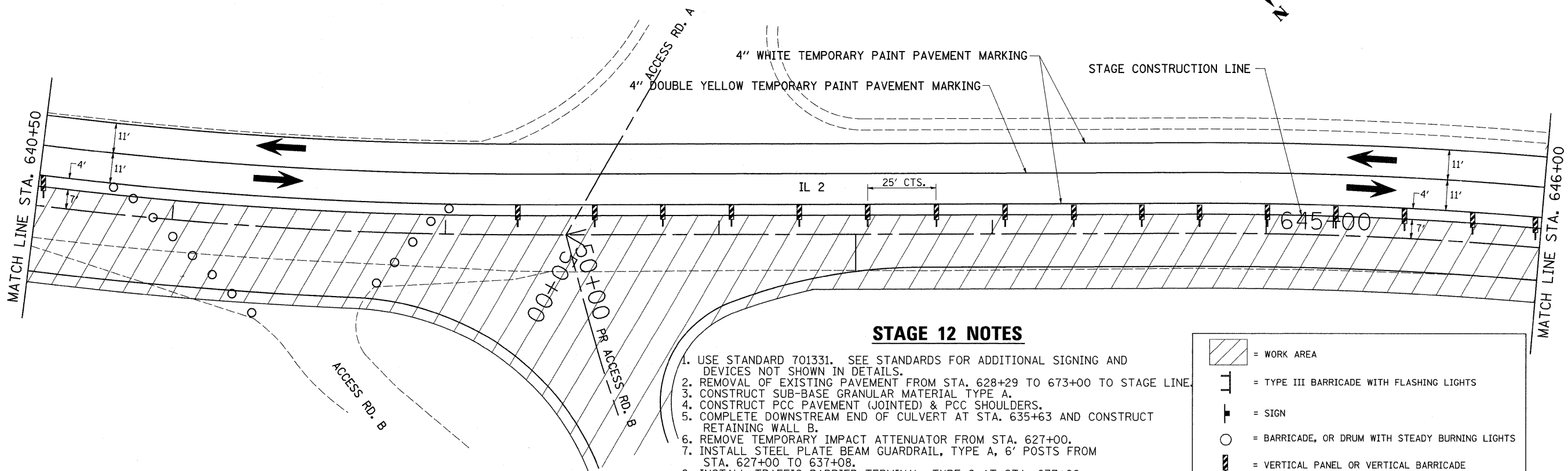

STAGE 12 NOTES

1. USE STANDARD 701331. SEE STANDARDS FOR ADDITIONAL SIGNING AND DEVICES NOT SHOWN IN DETAILS.
2. REMOVAL OF EXISTING PAVEMENT FROM STA. 628+29 TO 673+00 TO STAGE LINE.
3. CONSTRUCT SUB-BASE GRANULAR MATERIAL TYPE A.
4. CONSTRUCT PCC PAVEMENT (JOINTED) & PCC SHOULDERS.
5. COMPLETE DOWNSTREAM END OF CULVERT AT STA. 635+63 AND CONSTRUCT RETAINING WALL B.
6. REMOVE TEMPORARY IMPACT ATTENUATOR FROM STA. 627+00.
7. INSTALL STEEL PLATE BEAM GUARDRAIL, TYPE A, 6' POSTS FROM STA. 627+00 TO 637+08.
8. INSTALL TRAFFIC BARRIER TERMINAL, TYPE 2 AT STA. 637+08.

	= WORK AREA
	= TYPE III BARRICADE WITH FLASHING LIGHTS
	= SIGN
	= BARRICADE, OR DRUM WITH STEADY BURNING LIGHTS
	= VERTICAL PANEL OR VERTICAL BARRICADE

FILE NAME =	USER NAME = cushmanbw	DESIGNED -	REVISED -
ct:\pw_work\PW\DOT\CUSHMANBW\dms34123\066486stg69.dgn		DRAWN -	REVISED -
PLOT SCALE = 20,0000' / IN.		CHECKED -	REVISED -
PLOT DATE = Fri May 01 07:38:55 2009		DATE -	REVISED -

STATE OF ILLINOIS
DEPARTMENT OF TRANSPORTATION

STAGE 12

SCALE:	SHEET NO. OF SHEETS	STA. TO STA.	F.A.P. RTE. 742	SECTION 37RS-3	COUNTY OGLE	TOTAL SHEETS 345	SHEET NO. 108
			CONTRACT NO. 84788				
FED. ROAD DIST. NO. ILLINOIS FED. AID PROJECT							



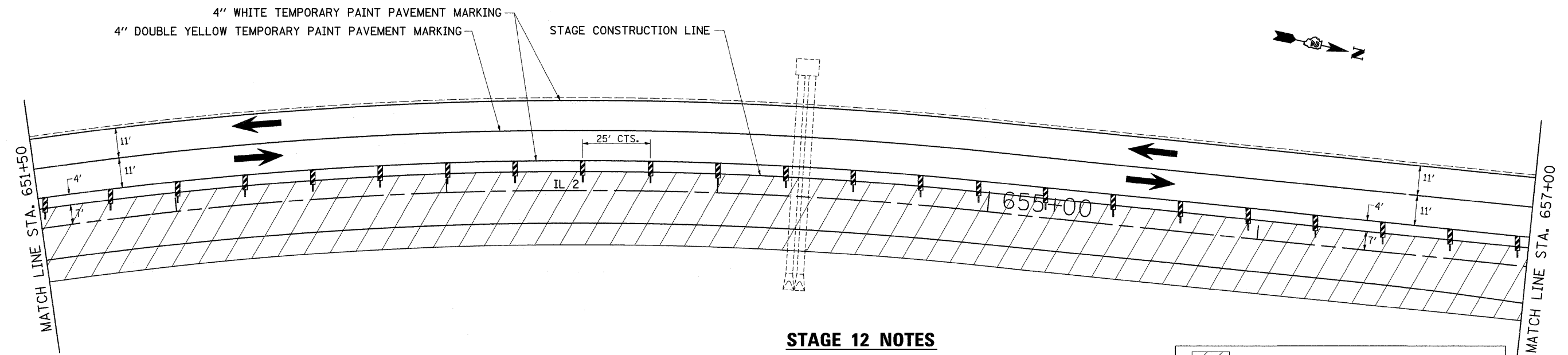
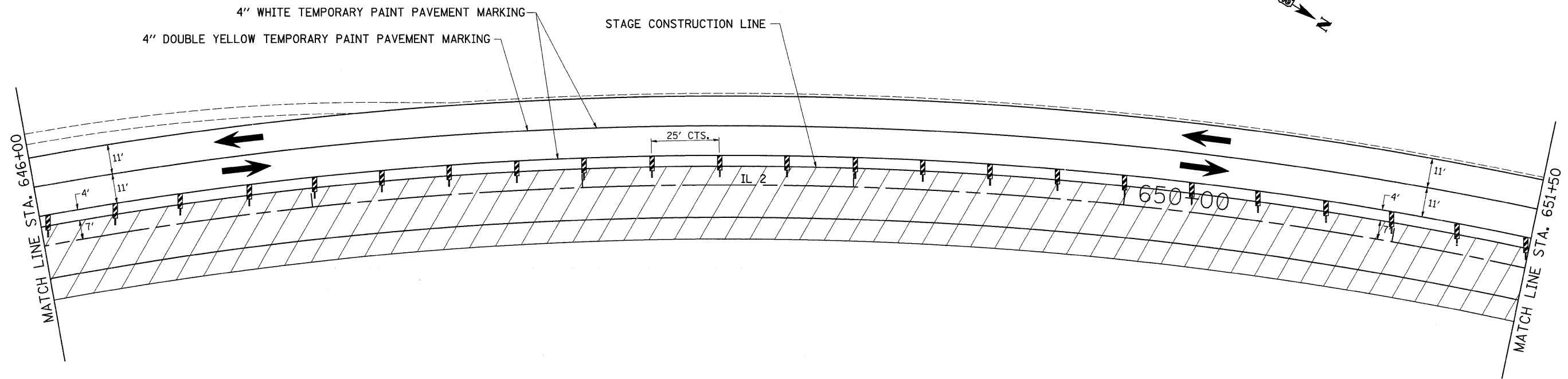

STAGE 12

STA. 628 + 29 - 673 + 00



STAGE 12 NOTES

1. USE STANDARD 701331. SEE STANDARDS FOR ADDITIONAL SIGNING AND DEVICES NOT SHOWN IN DETAILS.
2. REMOVAL OF EXISTING PAVEMENT FROM STA. 628+29 TO 673+00 TO STAGE LINE.
3. CONSTRUCT SUB-BASE GRANULAR MATERIAL TYPE A.
4. CONSTRUCT PCC PAVEMENT (JOINTED) & PCC SHOULDERS.
5. COMPLETE DOWNSTREAM END OF CULVERT AT STA. 635+63 AND CONSTRUCT RETAINING WALL B.
6. REMOVE TEMPORARY IMPACT ATTENUATOR FROM STA. 627+00.
7. INSTALL STEEL PLATE BEAM GUARDRAIL, TYPE A, 6' POSTS FROM STA. 627+00 TO 637+08.
8. INSTALL TRAFFIC BARRIER TERMINAL, TYPE 2 AT STA. 637+08.

	= WORK AREA
	= TYPE III BARRICADE WITH FLASHING LIGHTS
	= SIGN
	= BARRICADE, OR DRUM WITH STEADY BURNING LIGHTS
	= VERTICAL PANEL OR VERTICAL BARRICADE

FILE NAME =	USER NAME = cushmanbw	DESIGNED -	REVISED -	STATE OF ILLINOIS DEPARTMENT OF TRANSPORTATION	STAGE 12	F.A.P. RTE. 742	SECTION 37RS-3	COUNTY OGLE	TOTAL SHEETS 345	SHEET NO. 109	
or\pwwork\PWIDOT\CUSHMANBW\dms34123\6486stg69.dgn	PLLOT SCALE = 20,0000' / IN.	DRAWN -	REVISED -			SCALE:	SHEET NO. OF SHEETS	STA. TO STA.	FED. ROAD DIST. NO.	ILLINOIS FED. AID PROJECT	CONTRACT NO. 84788
	PLLOT DATE = Fri May 01 07:39:07 2009	CHECKED -	REVISED -								
		DATE -	REVISED -								

STAGE 12

STA. 628+29 - 673+00

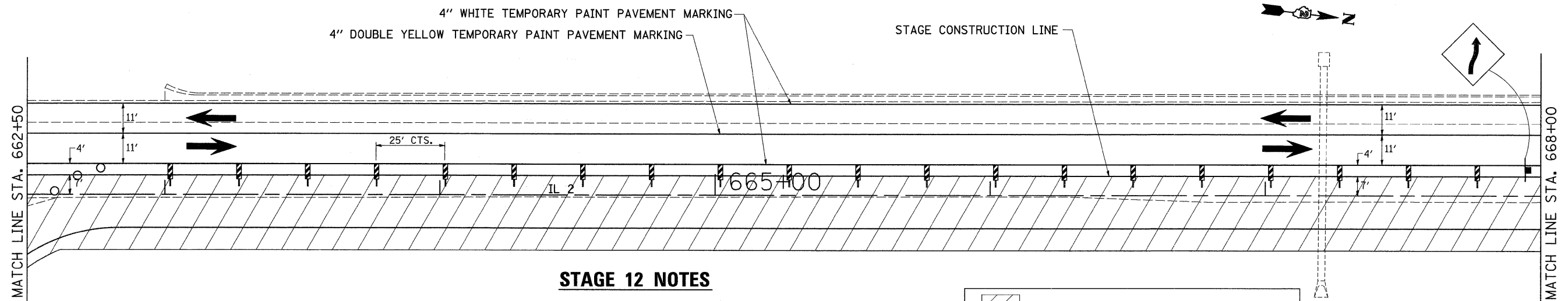
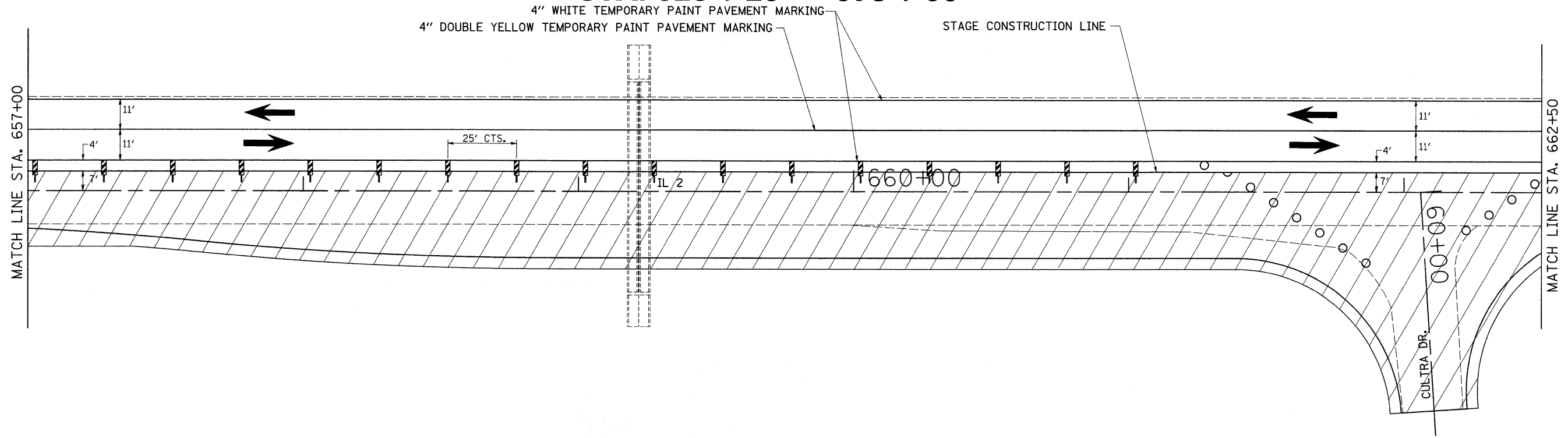

STAGE 12 NOTES

1. USE STANDARD 701331. SEE STANDARDS FOR ADDITIONAL SIGNING AND DEVICES NOT SHOWN IN DETAILS.
2. REMOVAL OF EXISTING PAVEMENT FROM STA. 628+29 TO 673+00 TO STAGE LINE.
3. CONSTRUCT SUB-BASE GRANULAR MATERIAL TYPE A.
4. CONSTRUCT PCC PAVEMENT (JOINTED) & PCC SHOULDERS.
5. COMPLETE DOWNSTREAM END OF CULVERT AT STA. 635+63 AND CONSTRUCT RETAINING WALL B.
6. REMOVE TEMPORARY IMPACT ATTENUATOR FROM STA. 627+00.
7. INSTALL STEEL PLATE BEAM GUARDRAIL, TYPE A, 6' POSTS FROM STA. 627+00 TO 637+08.
8. INSTALL TRAFFIC BARRIER TERMINAL, TYPE 2 AT STA. 637+08.

	= WORK AREA
	= TYPE III BARRICADE WITH FLASHING LIGHTS
	= SIGN
	= BARRICADE, OR DRUM WITH STEADY BURNING LIGHTS
	= VERTICAL PANEL OR VERTICAL BARRICADE

FILE NAME =	USER NAME = cushmanbw	DESIGNED -	REVISED -
es:\pw_work\PWIDOT\CUSHMANBW\dms34123\06486stg69.dgn		DRAWN -	REVISED -
PLOT SCALE = 20.0000' / IN.		CHECKED -	REVISED -
PLOT DATE = Fri May 01 07:39:19 2009		DATE -	REVISED -

STATE OF ILLINOIS
DEPARTMENT OF TRANSPORTATION

STAGE 12

SCALE: SHEET NO. OF SHEETS STA. TO STA.

F.A.P. RTE.	SECTION	COUNTY	TOTAL SHEETS	SHEET NO.
742	37RS-3	OGLE	345	110
CONTRACT NO. 84788				
FED. ROAD DIST. NO. ILLINOIS FED. AID PROJECT				

STAGE 12

STA. 628 + 29 - 673 + 00

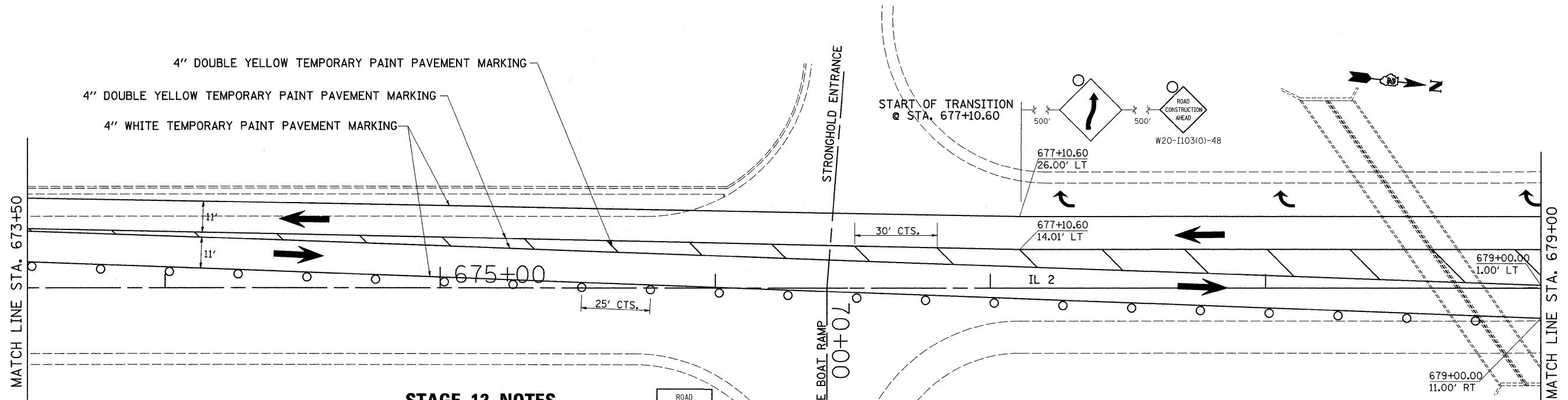
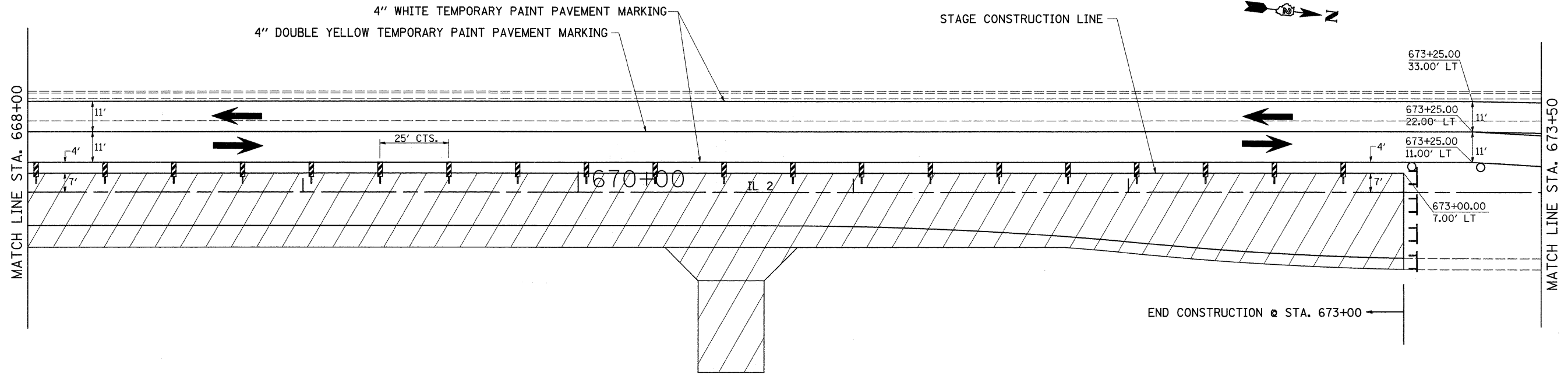

STAGE 12 NOTES

1. USE STANDARD 701331. SEE STANDARDS FOR ADDITIONAL SIGNING AND DEVICES NOT SHOWN IN DETAILS.
2. REMOVAL OF EXISTING PAVEMENT FROM STA. 628+29 TO 673+00 TO STAGE LINE.
3. CONSTRUCT SUB-BASE GRANULAR MATERIAL TYPE A.
4. CONSTRUCT PCC PAVEMENT (JOINTED) & PCC SHOULDERS.
5. COMPLETE DOWNSTREAM END OF CULVERT AT STA. 635+63 AND CONSTRUCT RETAINING WALL B.
6. REMOVE TEMPORARY IMPACT ATTENUATOR FROM STA. 627+00.
7. INSTALL STEEL PLATE BEAM GUARDRAIL, TYPE A, 6' POSTS FROM STA. 627+00 TO 637+08.
8. INSTALL TRAFFIC BARRIER TERMINAL, TYPE 2 AT STA. 637+08.

	= WORK AREA
	= TYPE III BARRICADE WITH FLASHING LIGHTS
	= SIGN
	= BARRICADE, OR DRUM WITH STEADY BURNING LIGHTS
	= VERTICAL PANEL OR VERTICAL BARRICADE

FILE NAME =	USER NAME = cushmanbw	DESIGNED -	REVISED -	STATE OF ILLINOIS DEPARTMENT OF TRANSPORTATION	STAGE 12	F.A.P. RTE.	SECTION	COUNTY	TOTAL SHEETS	SHEET NO.	
ci:\pwork\pwork\IDOT\CUSHMANBW\dms34123\dms34123.dgn	6486stg69.dgn	DRAWN -	REVISED -			742	37RS-3	OGLE	345	111	
PLOT SCALE = 20,0000' / IN.	CHECKED -	REVISED -	REVISED -			CONTRACT NO. 84788					
PLOT DATE = Fri May 01 07:39:32 2009	DATE -	REVISED -	REVISED -			FED. ROAD DIST. NO. [ILLINOIS] FED. AID PROJECT					

STAGE 12

STA. 628 + 29 - 673 + 00

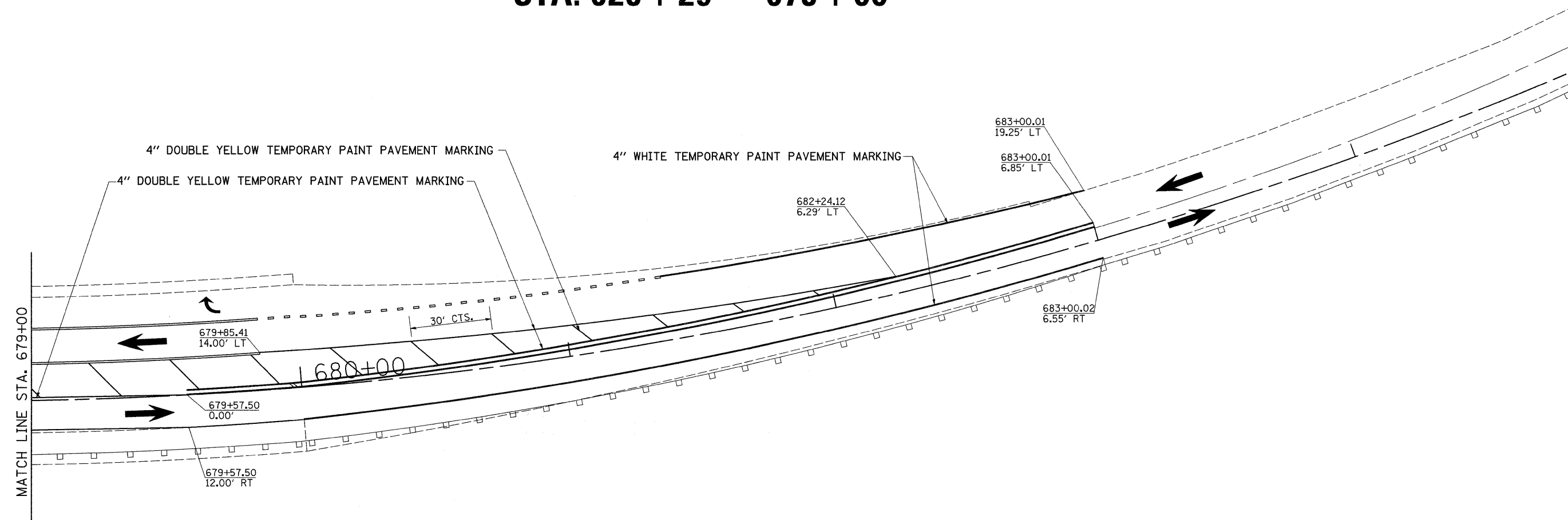

STAGE 12 NOTES

1. USE STANDARD 701331. SEE STANDARDS FOR ADDITIONAL SIGNING AND DEVICES NOT SHOWN IN DETAILS.
2. REMOVAL OF EXISTING PAVEMENT FROM STA. 628+29 TO 673+00 TO STAGE LINE.
3. CONSTRUCT SUB-BASE GRANULAR MATERIAL TYPE A.
4. CONSTRUCT PCC PAVEMENT (JOINTED) & PCC SHOULDERS.
5. COMPLETE DOWNSTREAM END OF CULVERT AT STA. 635+63 AND CONSTRUCT RETAINING WALL B.
6. REMOVE TEMPORARY IMPACT ATTENUATOR FROM STA. 627+00.
7. INSTALL STEEL PLATE BEAM GUARDRAIL, TYPE A, 6' POSTS FROM STA. 627+00 TO 637+08.
8. INSTALL TRAFFIC BARRIER TERMINAL, TYPE 2 AT STA. 637+08.

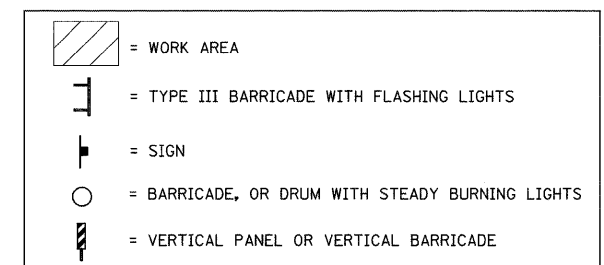

FILE NAME =	USER NAME = cushmanbw	DESIGNED -	REVISED -	STATE OF ILLINOIS DEPARTMENT OF TRANSPORTATION	STAGE 12	F.A.P. RTE.	SECTION	COUNTY	TOTAL SHEETS	SHEET NO.	
cd\pwwork\PWIDOT\CUSHMANBW\dms34123\6486stg69.dgn	6486stg69.dgn	DRAWN -	REVISED -			742	37RS-3	OGLE	345	112	
PLOT SCALE = 20,0000' / IN.	CHECKED -	REVISED -	REVISED -			SCALE: SHEET NO. OF SHEETS STA. TO STA.		CONTRACT NO. 84788			
PLOT DATE = Fri May 01 07:41:03 2009	DATE -	REVISED -	REVISED -			FED. ROAD DIST. NO. ILLINOIS FED. AID PROJECT					

STAGE 13









STA. 603 + 08 - 683 + 00

STAGE 13 NOTES







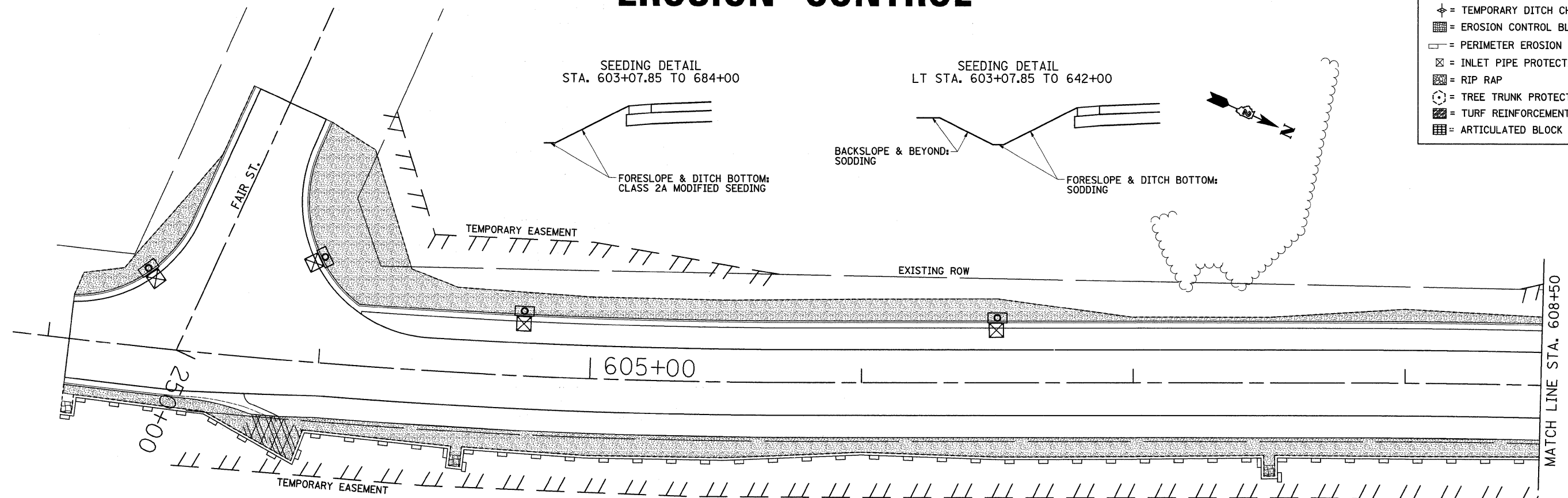

1. USE STANDARD 701306, 701311 AND/OR 701701. SEE STANDARDS FOR ADDITIONAL SIGNING AND DEVICES NOT SHOWN IN DETAILS.
3. COMPLETE FINAL PAVEMENT MARKING, LANDSCAPING AND CLEAN-UP WORK.

FILE NAME =	USER NAME = cushmanbw	DESIGNED -	REVISED -	STATE OF ILLINOIS DEPARTMENT OF TRANSPORTATION	STAGE 13	F.A.P. RTE.	SECTION	COUNTY	TOTAL SHEETS	SHEET NO.
c:\pwwork\pwwork\CUSHMANBW\dms34123\6486stg69.dgn	6486stg69.dgn	DRAWN -	REVISED -			742	37RS-3	OGLE	345	113
PLOT SCALE = 20.0000' / IN.	CHECKED -	REVISED -	SCALE: SHEET NO. OF SHEETS STA. TO STA. FED. ROAD DIST. NO. ILLINOIS FED. AID PROJECT							
PLOT DATE = Fri May 01 07:40:47 2009	DATE -	REVISED -	CONTRACT NO. 84788							

EROSION CONTROL

-  = SEEDING OR SOD
-  = TEMPORARY DITCH CHECKS
-  = EROSION CONTROL BLANKET
-  = PERIMETER EROSION BARRIER
-  = INLET PIPE PROTECTION
-  = RIP RAP
-  = TREE TRUNK PROTECTION
-  = TURF REINFORCEMENT MAT
-  = ARTICULATED BLOCK MAT



-  = SEEDING OR SOD
-  = TEMPORARY DITCH CHECKS
-  = EROSION CONTROL BLANKET
-  = PERIMETER EROSION BARRIER
-  = INLET PIPE PROTECTION
-  = RIP RAP
-  = TREE TRUNK PROTECTION
-  = TURF REINFORCEMENT MAT
-  = ARTICULATED BLOCK MAT

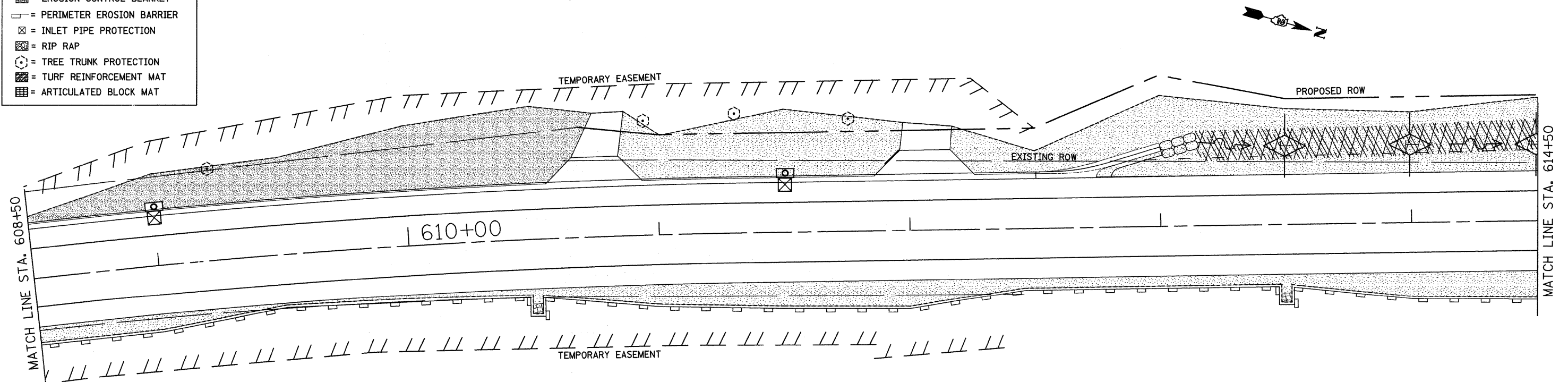

FILE NAME =	USER NAME = cushmanbw	DESIGNED -	REVISED -	STATE OF ILLINOIS DEPARTMENT OF TRANSPORTATION	EROSION CONTROL	F.A.P. RTE.	SECTION	COUNTY	TOTAL SHEETS	SHEET NO.	
c:\pwork\FWIDOT\CUSHMANBW\dms34123\dms34123.dwg	6486er.dgn	DRAWN -	REVISED -			742	37R-3	OGLE	345	114	
PLOT SCALE = 28.0000' / IN.	CHECKED -	REVISED -	REVISED -			CONTRACT NO. 84788					
PLOT DATE = Fri May 01 08:02:11 2009	DATE -	REVISED -	REVISED -			FED. ROAD DIST. NO. ILLINOIS FED. AID PROJECT					
SCALE: SHEET NO. OF SHEETS STA. TO STA.											

EROSION CONTROL

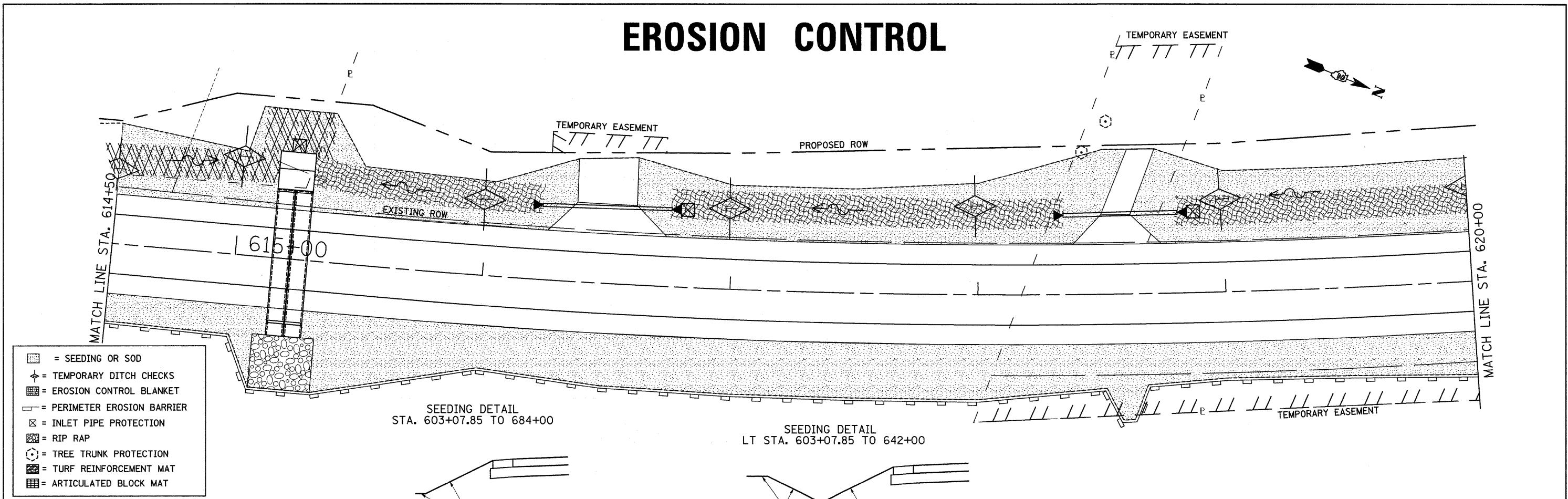

- = SEEDING OR SOD
- = TEMPORARY DITCH CHECKS
- = EROSION CONTROL BLANKET
- = PERIMETER EROSION BARRIER
- = INLET PIPE PROTECTION
- = RIP RAP
- = TREE TRUNK PROTECTION
- = TURF REINFORCEMENT MAT
- = ARTICULATED BLOCK MAT

SEEDING DETAIL
STA. 603+07.85 TO 684+00

SEEDING DETAIL
LT STA. 603+07.85 TO 642+00

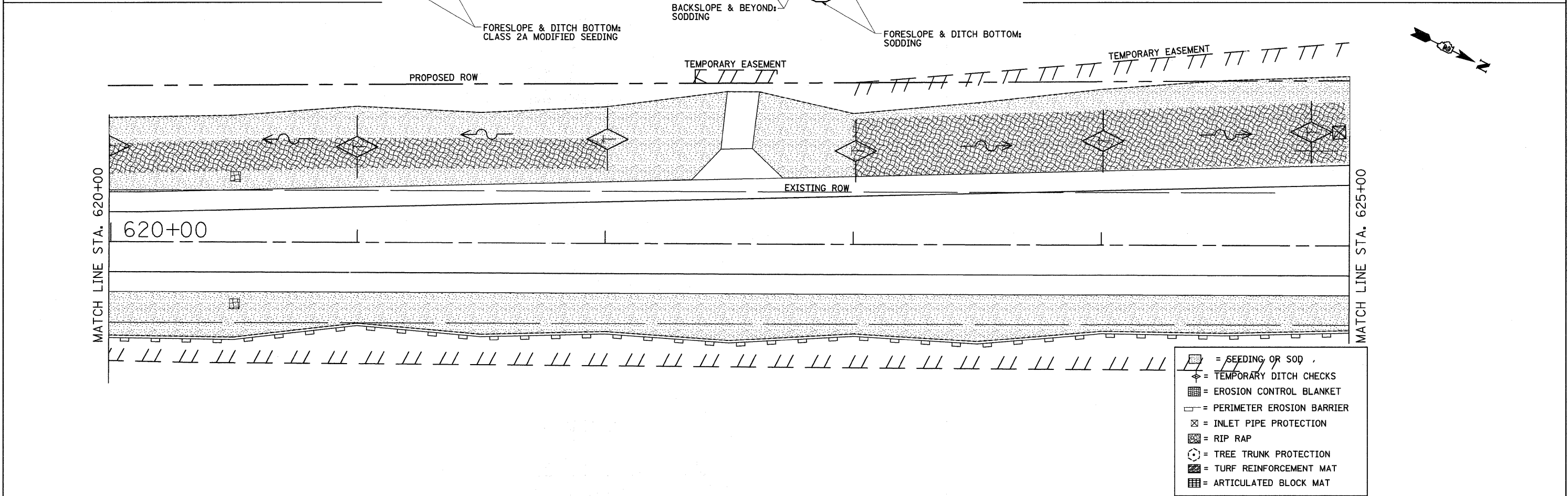
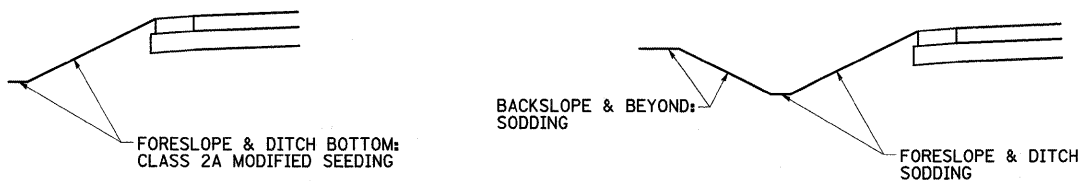

- = SEEDING OR SOD
- = TEMPORARY DITCH CHECKS
- = EROSION CONTROL BLANKET
- = PERIMETER EROSION BARRIER
- = INLET PIPE PROTECTION
- = RIP RAP
- = TREE TRUNK PROTECTION
- = TURF REINFORCEMENT MAT
- = ARTICULATED BLOCK MAT

FILE NAME =	USER NAME = cushmanbw	DESIGNED -	REVISED -	STATE OF ILLINOIS DEPARTMENT OF TRANSPORTATION	EROSION CONTROL	SCALE:	SHEET NO. OF SHEETS	STA. TO STA.	F.A.P. RTE. 742	SECTION 37R-3	COUNTY OGLE	TOTAL SHEETS 345	SHEET NO. 115
cr\pw_work\PWIDOT\CUSHMANBW\dms34123\05496err.dgn	PLOT SCALE = 20.0000' / IN.	DRAWN -	REVISED -			CONTRACT NO. 84788							
PLOT DATE = Fri May 01 08:02:16 2009	DATE -	CHECKED -	REVISED -			ILLINOIS FED. AID PROJECT							

EROSION CONTROL

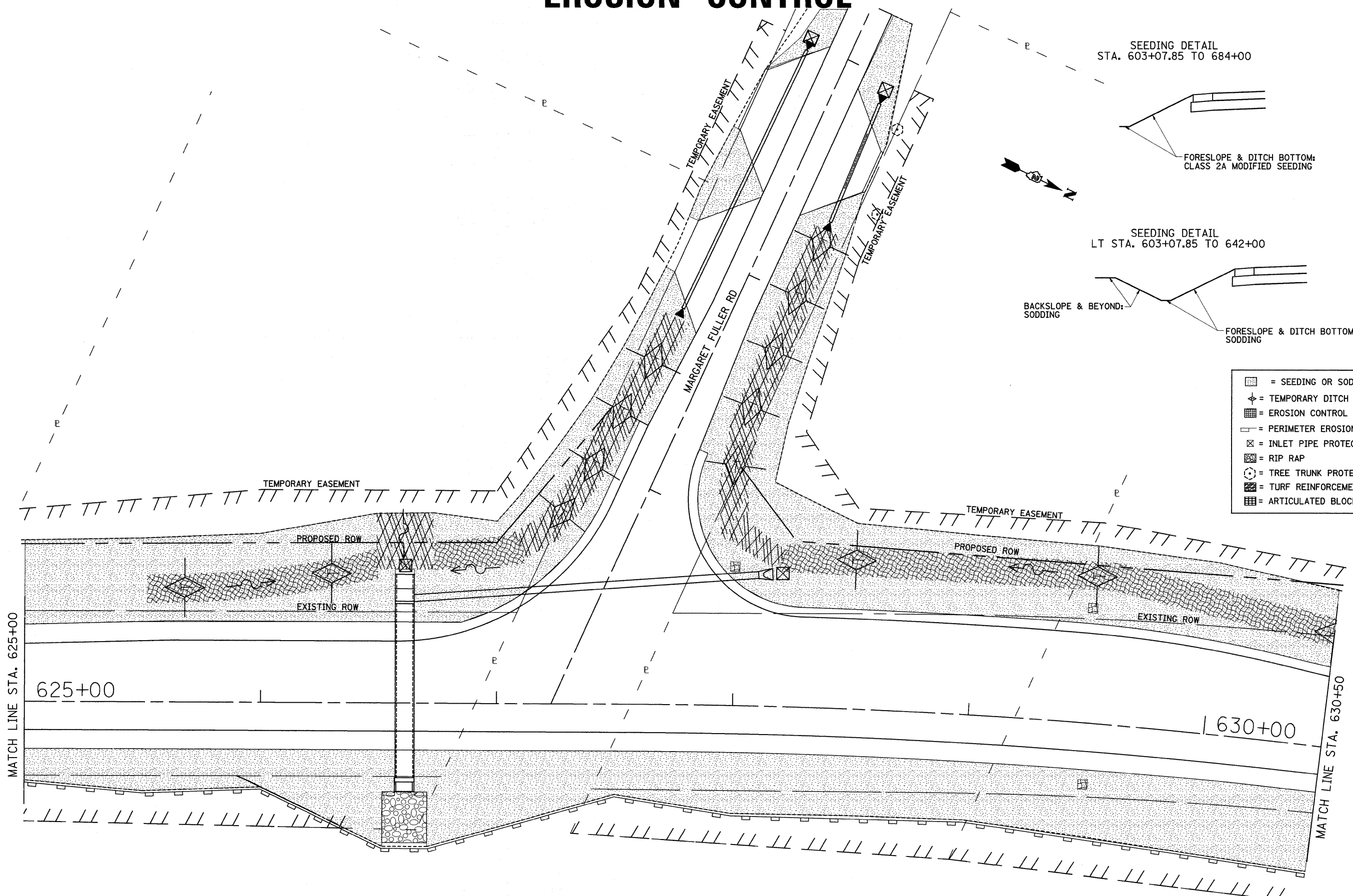

SEEDING DETAIL
STA. 603+07.85 TO 684+00

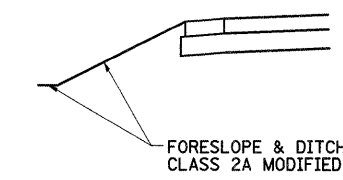

SEEDING DETAIL
LT STA. 603+07.85 TO 642+00

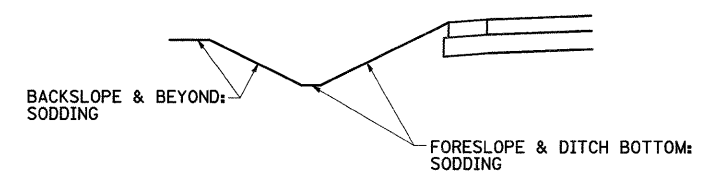

- = SEEDING OR SOD
- = TEMPORARY DITCH CHECKS
- = EROSION CONTROL BLANKET
- = PERIMETER EROSION BARRIER
- = INLET PIPE PROTECTION
- = RIP RAP
- = TREE TRUNK PROTECTION
- = TURF REINFORCEMENT MAT
- = ARTICULATED BLOCK MAT

FILE NAME =	USER NAME = cushmanbw	DESIGNED -	REVISED -	STATE OF ILLINOIS	EROSION CONTROL	F.A.P. RTE.	SECTION	COUNTY	TOTAL SHEETS	SHEET NO.
ct\pw_work\PW\DOT\CUSHMANBW\dms34123\dms34123.dwg	dms34123.dwg	DRAWN -	REVISED -	DEPARTMENT OF TRANSPORTATION		742	37R-3	OGLE	345	116
		PLOT SCALE = 20.0000' / IN.	CHECKED -						CONTRACT NO. 84788	
		PLOT DATE = Fri May 01 08:02:03 2009	DATE -						ILLINOIS FED. AID PROJECT	
				SCALE:		SHEET NO. OF SHEETS		STA. TO STA.		

EROSION CONTROL

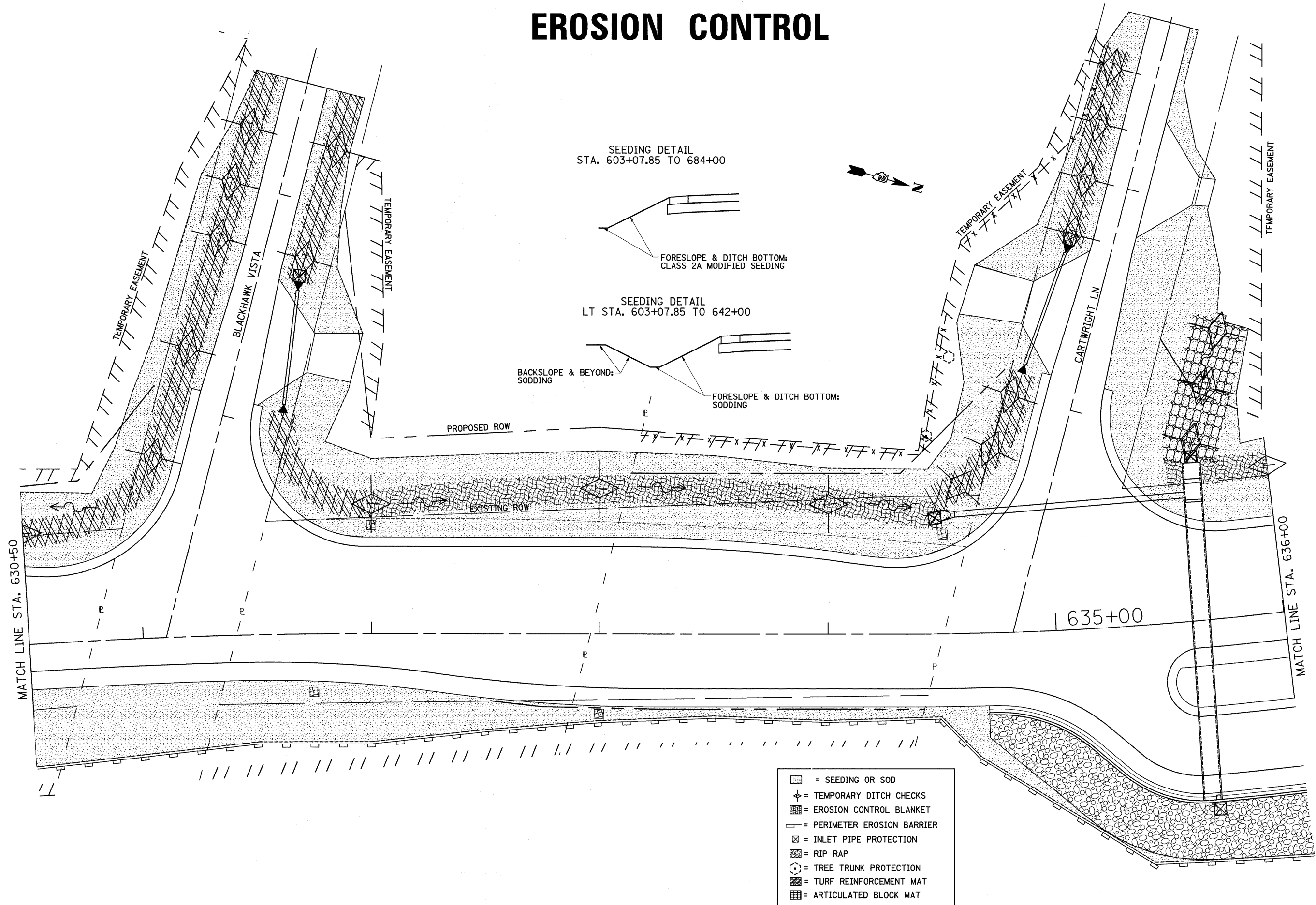

SEEDING DETAIL
STA. 603+07.85 TO 684+00

SEEDING DETAIL
LT STA. 603+07.85 TO 642+00

- [Grid] = SEEDING OR SOD
- [Cross] = TEMPORARY DITCH CHECKS
- [Stippled] = EROSION CONTROL BLANKET
- [Dashed] = PERIMETER EROSION BARRIER
- [Cross-hatched] = INLET PIPE PROTECTION
- [Stone] = RIP RAP
- [Circle] = TREE TRUNK PROTECTION
- [Cross-hatched] = TURF REINFORCEMENT MAT
- [Grid] = ARTICULATED BLOCK MAT

FILE NAME =	USER NAME = cushmanbw	DESIGNED -	REVISED -	STATE OF ILLINOIS DEPARTMENT OF TRANSPORTATION	EROSION CONTROL	F.A.P. RTE.	SECTION	COUNTY	TOTAL SHEETS	SHEET NO.	
α\p\work\PWIDOT\CUSHMANBW\dms34123\dms34123.dgn		DRAWN -	REVISED -			742	37R-3	OGLE	345	117	
PLOT SCALE = 20,0000' / IN.		CHECKED -	REVISED -			CONTRACT NO. 84788					
PLOT DATE = Fri May 01 08:01:10 2009		DATE -	REVISED -			FED. ROAD DIST. NO. ILLINOIS FED. AID PROJECT					
SCALE:						SHEET NO. OF SHEETS STA. TO STA.					

EROSION CONTROL

SEEDING DETAIL
STA. 603+07.85 TO 684+00

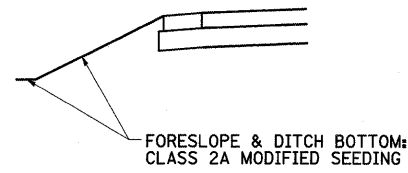

SEEDING DETAIL
LT STA. 603+07.85 TO 642+00

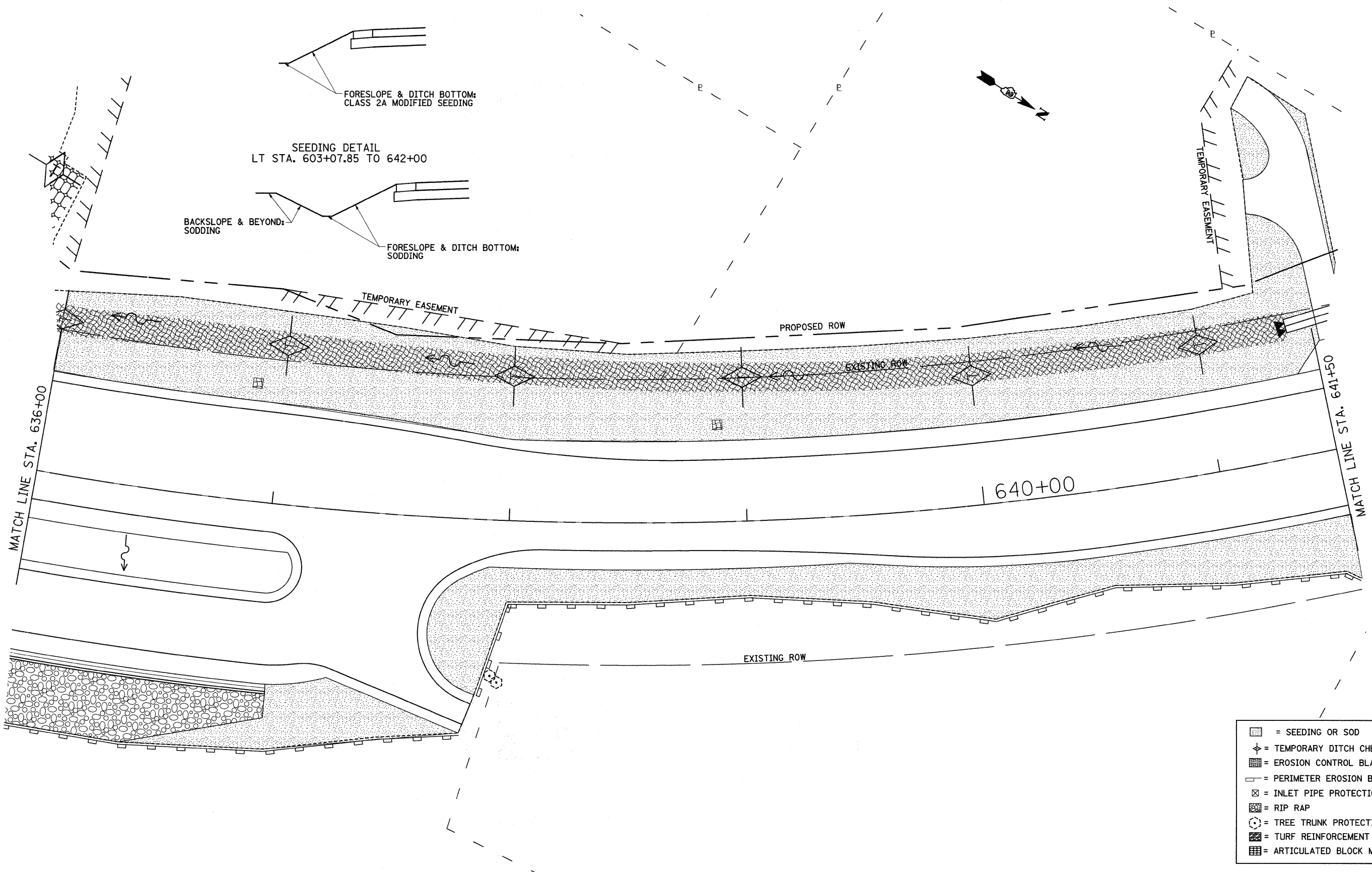
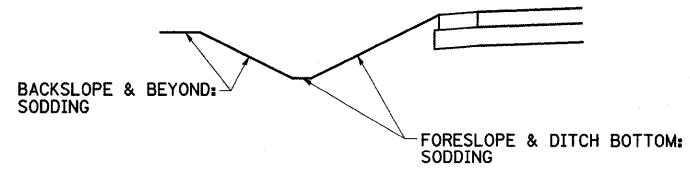

- = SEEDING OR SOD
- = TEMPORARY DITCH CHECKS
- = EROSION CONTROL BLANKET
- = PERIMETER EROSION BARRIER
- = INLET PIPE PROTECTION
- = RIP RAP
- = TREE TRUNK PROTECTION
- = TURF REINFORCEMENT MAT
- = ARTICULATED BLOCK MAT

FILE NAME =	USER NAME = cushmanbw	DESIGNED -	REVISED -
ct:\pw_work\PW\DOT\CUSHMANBW\dms34123\dms34123.dwg	dms34123.dwg	DRAWN -	REVISED -
	PLOT SCALE = 20.0000' / IN.	CHECKED -	REVISED -
	PLOT DATE = Fri May 01 08:01:18 2009	DATE -	REVISED -









**STATE OF ILLINOIS
DEPARTMENT OF TRANSPORTATION**

EROSION CONTROL

SCALE: SHEET NO. OF SHEETS STA. TO STA.

F.A.P. RTE.	SECTION	COUNTY	TOTAL SHEETS	SHEET NO.
742	37R-3	OGLE	345	118
CONTRACT NO. 84788				
FED. ROAD DIST. NO. ILLINOIS FED. AID PROJECT				

EROSION CONTROL

-  = SEEDING OR SOD
-  = TEMPORARY DITCH CHECKS
-  = EROSION CONTROL BLANKET
-  = PERIMETER EROSION BARRIER
-  = INLET PIPE PROTECTION
-  = RIP RAP
-  = TREE TRUNK PROTECTION
-  = TURF REINFORCEMENT MAT
-  = ARTICULATED BLOCK MAT

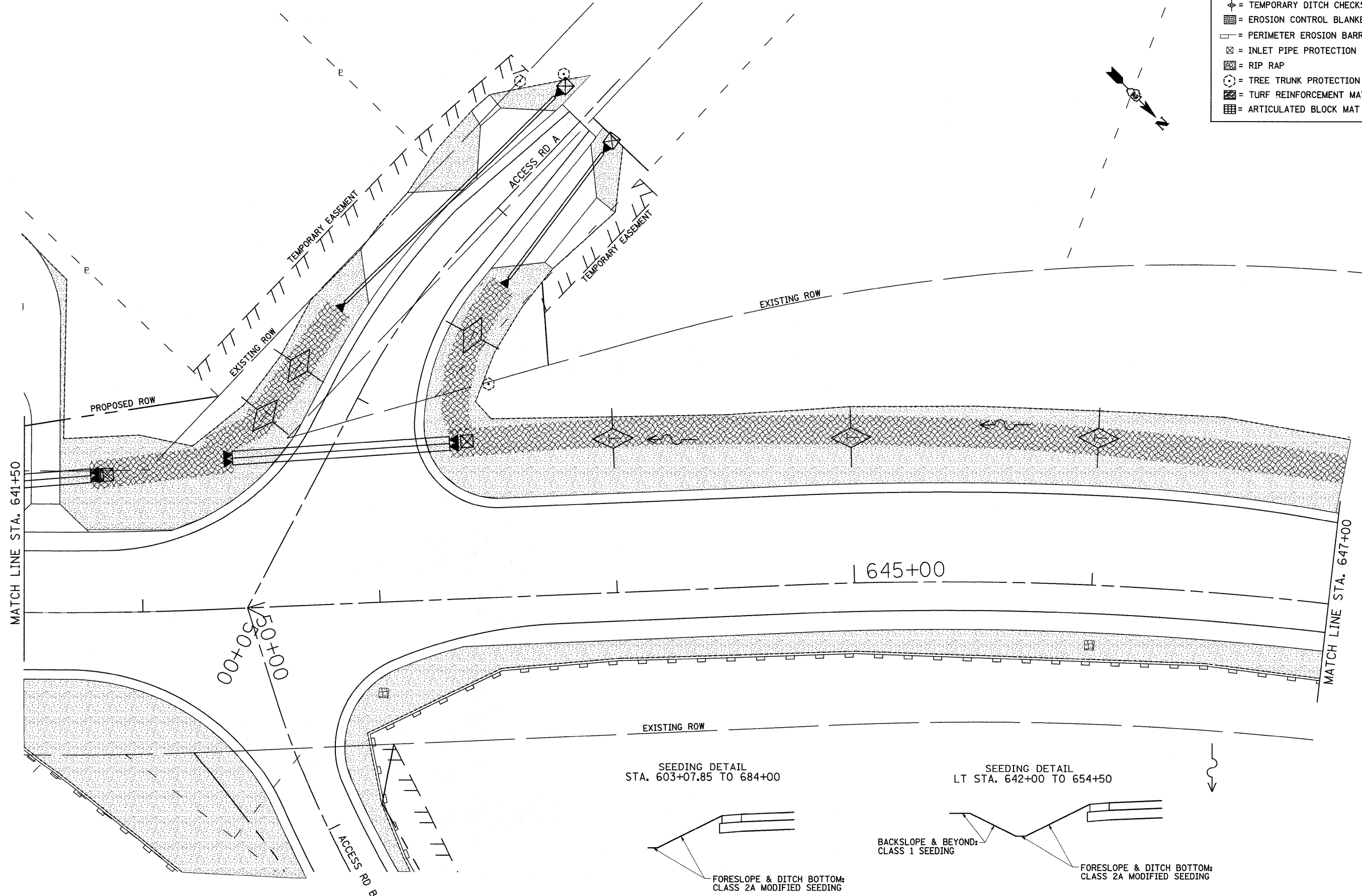

SEEDING DETAIL
STA. 603+07.85 TO 684+00

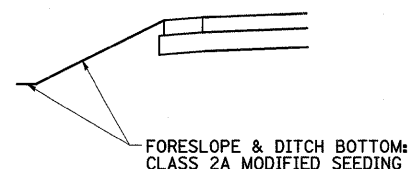

SEEDING DETAIL
LT STA. 642+00 TO 654+50

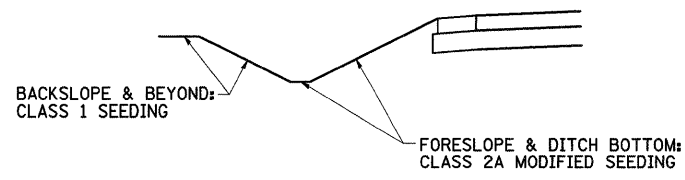

FILE NAME =	USER NAME = cushmanbw	DESIGNED -	REVISED -	STATE OF ILLINOIS	EROSION CONTROL	F.A.P. RTE.	SECTION	COUNTY	TOTAL SHEETS	SHEET NO.
ct\pw_work\PWIDOT\CUSHMANBW\dms34123\06486er.dgn		DRAWN -	REVISED -	DEPARTMENT OF TRANSPORTATION		742	37R-3	OGLE	345	119
		PLOT SCALE = 20.0000' / IN.	CHECKED -						CONTRACT NO. 84788	
		PLOT DATE = Fri May 01 08:01:24 2009	DATE -						ILLINOIS FED. AID PROJECT	
				SCALE:	SHEET NO. OF SHEETS	STA.	TO STA.			

EROSION CONTROL

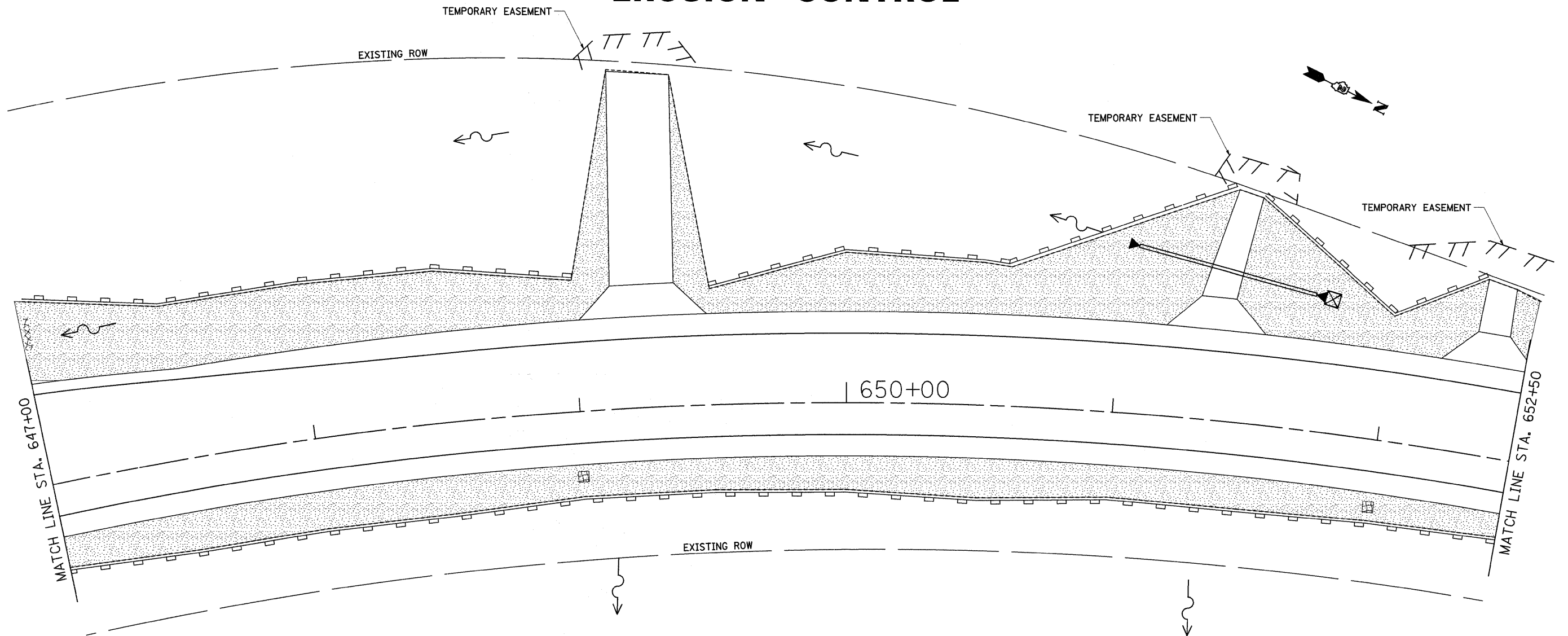

SEEDING DETAIL
STA. 603+07.85 TO 684+00

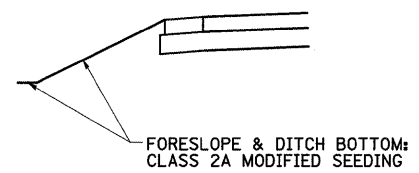

SEEDING DETAIL
LT STA. 642+00 TO 654+50

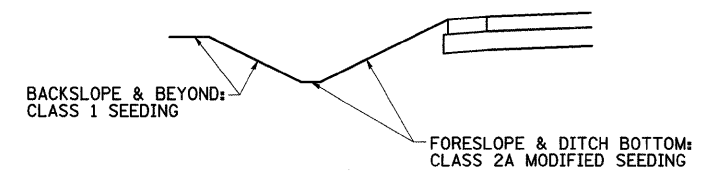

- = SEEDING OR SOD
- = TEMPORARY DITCH CHECKS
- = EROSION CONTROL BLANKET
- = PERIMETER EROSION BARRIER
- = INLET PIPE PROTECTION
- = RIP RAP
- = TREE TRUNK PROTECTION
- = TURF REINFORCEMENT MAT
- = ARTICULATED BLOCK MAT

FILE NAME =	USER NAME = cushmanbw	DESIGNED -	REVISED -
c:\pwork\PWIDOT\CUSHMANBW\dms34123\dms34123.dgn		DRAWN -	REVISED -
	PLOT SCALE = 20.0000' / IN.	CHECKED -	REVISED -
	PLOT DATE = Fri May 01 08:01:30 2009	DATE -	REVISED -

STATE OF ILLINOIS
DEPARTMENT OF TRANSPORTATION

EROSION CONTROL

SCALE: SHEET NO. OF SHEETS STA. TO STA.

F.A.P. RTE.	SECTION	COUNTY	TOTAL SHEETS	SHEET NO.
742	37R-3	OGLE	345	120
CONTRACT NO. 84788				
FED. ROAD DIST. NO. ILLINOIS FED. AID PROJECT				

EROSION CONTROL

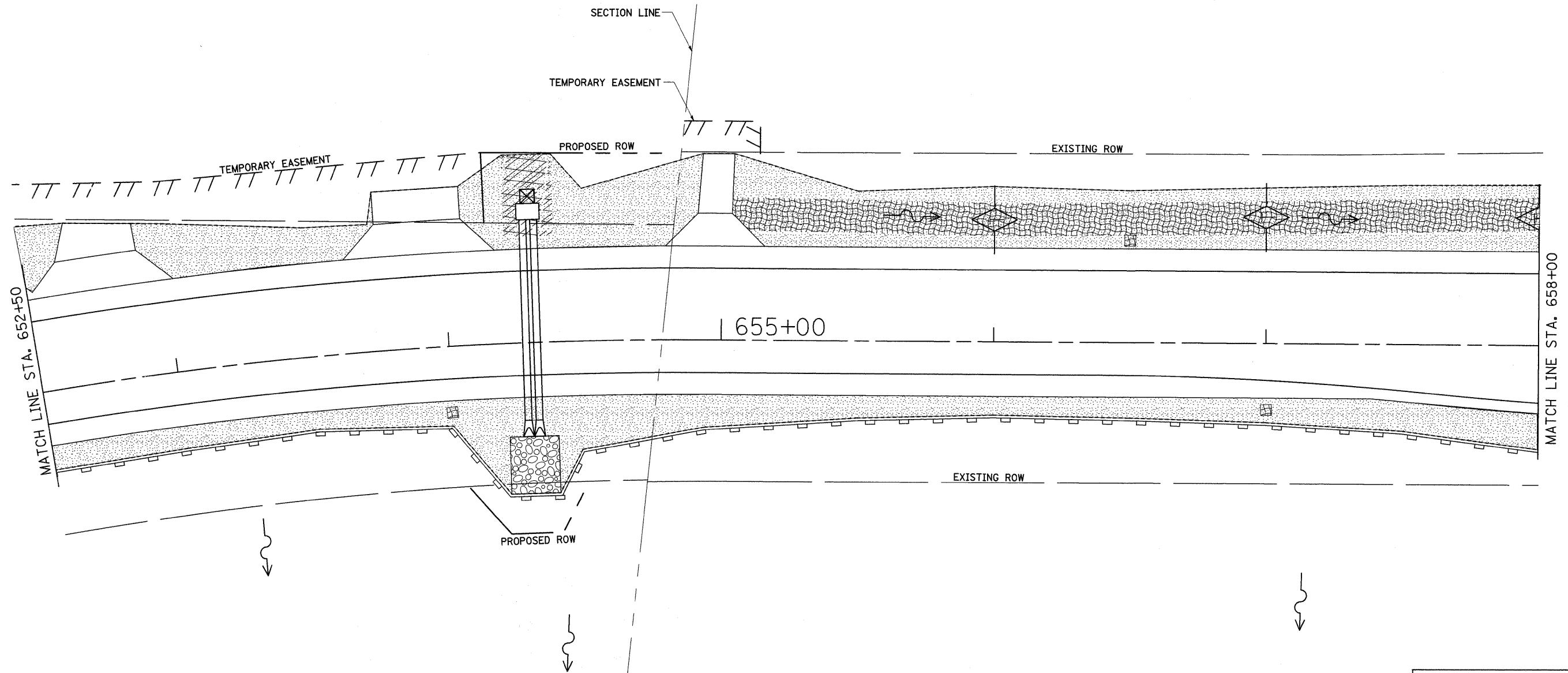

SEEDING DETAIL
STA. 603+07.85 TO 684+00

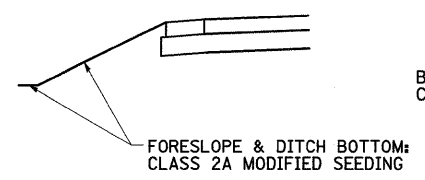

SEEDING DETAIL
LT STA. 654+50 TO 662+00

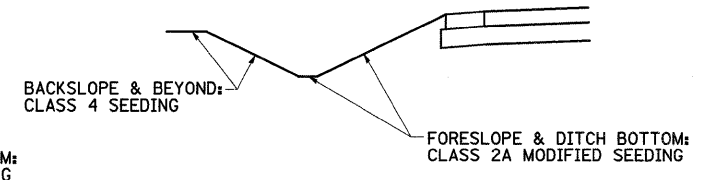

- = SEEDING OR SOD
- = TEMPORARY DITCH CHECKS
- = EROSION CONTROL BLANKET
- = PERIMETER EROSION BARRIER
- = INLET PIPE PROTECTION
- = RIP RAP
- = TREE TRUNK PROTECTION
- = TURF REINFORCEMENT MAT
- = ARTICULATED BLOCK MAT

FILE NAME =	USER NAME = cushmanbw	DESIGNED -	REVISED -
cr:\pw_work\FWIDOT\CUSHMANBW\dms34123\06486er.dgn		DRAWN -	REVISED -
	PLOT SCALE = 20.0000' / IN.	CHECKED -	REVISED -
	PLOT DATE = Fri May 01 08:01:34 2009	DATE -	REVISED -

**STATE OF ILLINOIS
DEPARTMENT OF TRANSPORTATION**

EROSION CONTROL

SCALE:	SHEET NO.	OF	SHEETS	STA.	TO STA.
--------	-----------	----	--------	------	---------

F.A.P. RTE.	SECTION	COUNTY	TOTAL SHEETS	SHEET NO.
742	37R-3	OGLE	345	121
CONTRACT NO. 84788				
FED. ROAD DIST. NO. ILLINOIS FED. AID PROJECT				

EROSION CONTROL

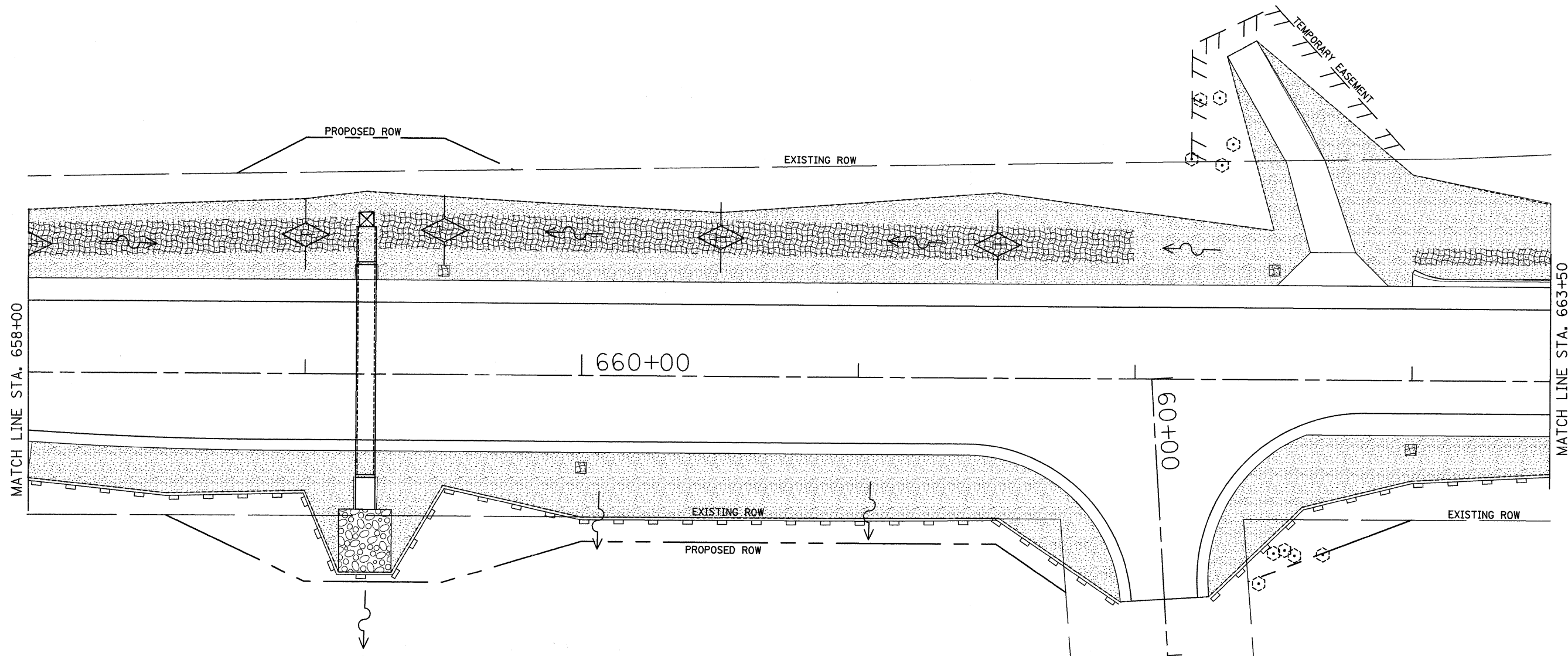

SEEDING DETAIL
STA. 603+07.85 TO 684+00

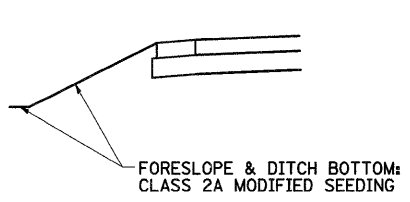

SEEDING DETAIL
LT STA. 654+50 TO 662+00

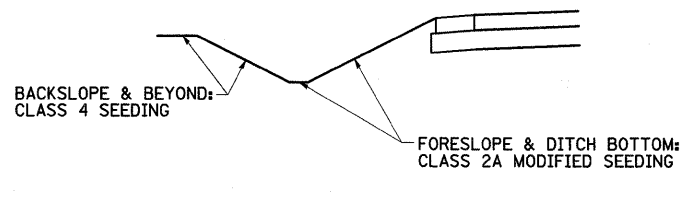

SEEDING DETAIL
LT STA. 662+00 TO 663+50

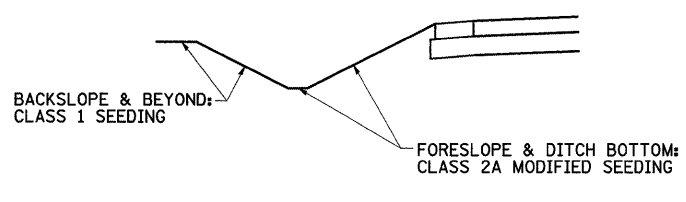

	= SEEDING OR SOD
	= TEMPORARY DITCH CHECKS
	= EROSION CONTROL BLANKET
	= PERIMETER EROSION BARRIER
	= INLET PIPE PROTECTION
	= RIP RAP
	= TREE TRUNK PROTECTION
	= TURF REINFORCEMENT MAT
	= ARTICULATED BLOCK MAT

FILE NAME =	USER NAME = cushmanbw	DESIGNED -	REVISED -
c:\pw_work\PWIDOT\CUSHMANBW\dms34123\06496er.dgn		DRAWN -	REVISED -
PLOT SCALE = 20.0000' / IN.		CHECKED -	REVISED -
PLOT DATE = Fri May 01 08:01:38 2009		DATE -	REVISED -

**STATE OF ILLINOIS
DEPARTMENT OF TRANSPORTATION**

EROSION CONTROL

SCALE:	SHEET NO.	OF	SHEETS	STA.	TO STA.
--------	-----------	----	--------	------	---------

F.A.P. RTE.	SECTION	COUNTY	TOTAL SHEETS	SHEET NO.
742	37R-3	OGLE	345	122
CONTRACT NO. 84788				
FED. ROAD DIST. NO.		ILLINOIS FED. AID PROJECT		

EROSION CONTROL

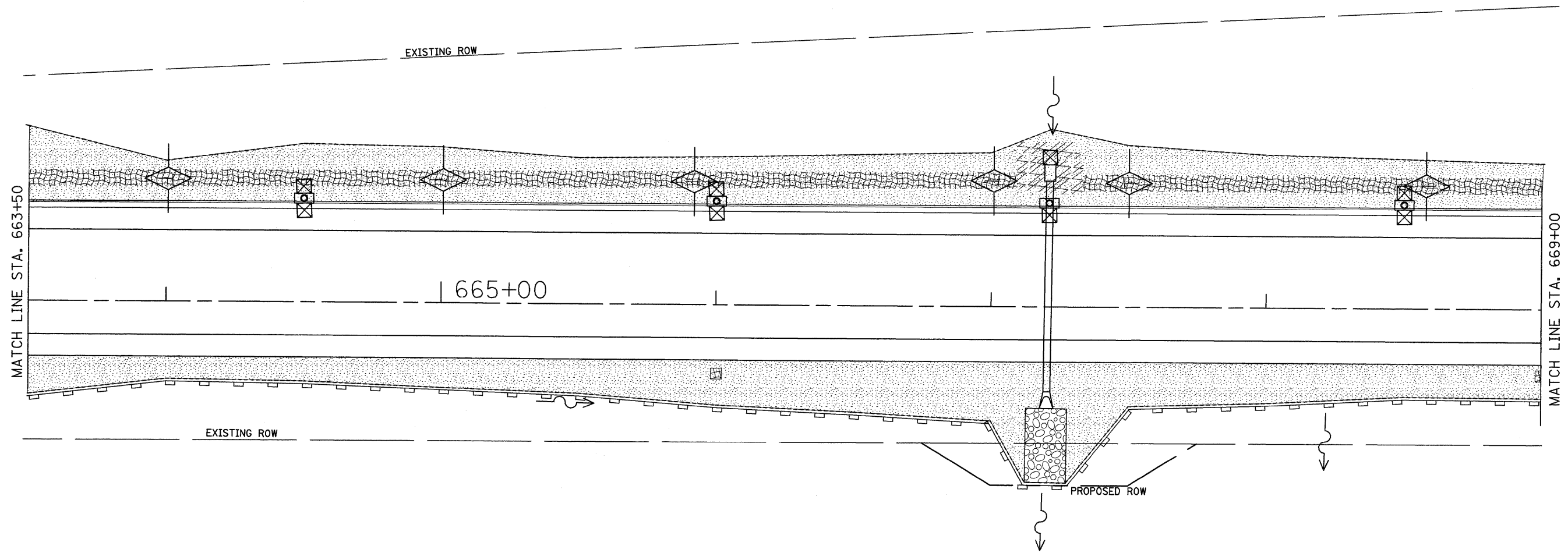

SEEDING DETAIL
STA. 603+07.85 TO 684+00

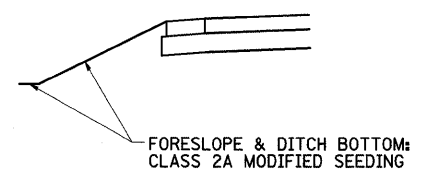

SEEDING DETAIL
LT STA. 663+50 TO 675+50

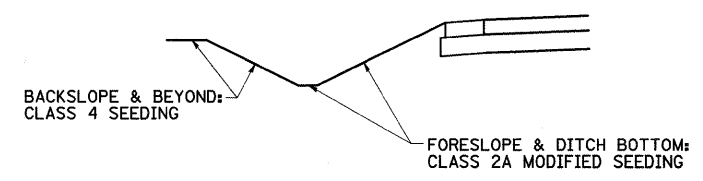

- | | |
|--|-----------------------------|
| | = SEEDING OR SOD |
| | = TEMPORARY DITCH CHECKS |
| | = EROSION CONTROL BLANKET |
| | = PERIMETER EROSION BARRIER |
| | = INLET PIPE PROTECTION |
| | = RIP RAP |
| | = TREE TRUNK PROTECTION |
| | = TURF REINFORCEMENT MAT |
| | = ARTICULATED BLOCK MAT |

FILE NAME =	USER NAME = cushmanbw	DESIGNED -	REVISED -
c:\pw_work\PW\DOT\CUSHMANBW\dms34123\dms34123.dwg		DRAWN -	REVISED -
	PLOT SCALE = 20.0000' / IN.	CHECKED -	REVISED -
	PLOT DATE = Fri May 01 08:01:43 2009	DATE -	REVISED -

**STATE OF ILLINOIS
DEPARTMENT OF TRANSPORTATION**

EROSION CONTROL

SCALE:	SHEET NO.	OF	SHEETS	STA.	TO STA.
--------	-----------	----	--------	------	---------

F.A.P. RTE.	SECTION	COUNTY	TOTAL SHEETS	SHEET NO.
742	37R-3	OGLE	345	123
CONTRACT NO. 84788				
FED. ROAD DIST. NO.		ILLINOIS FED. AID PROJECT		

EROSION CONTROL

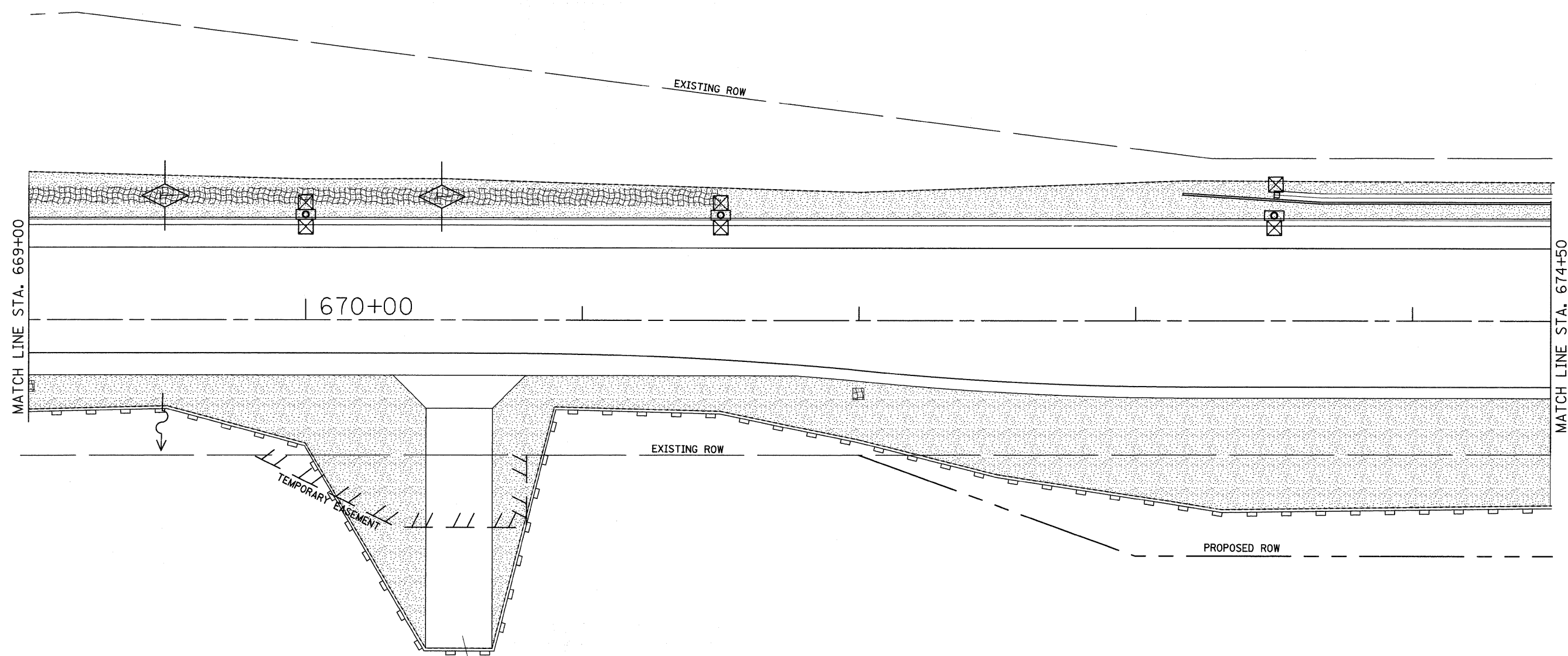

SEEDING DETAIL
STA. 603+07.85 TO 684+00

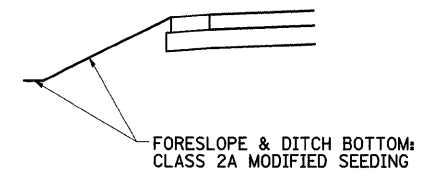

SEEDING DETAIL
LT STA. 663+50 TO 675+50

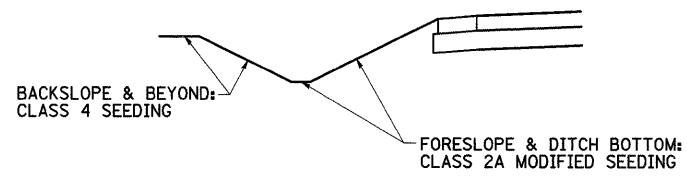

- = SEEDING OR SOD
- = TEMPORARY DITCH CHECKS
- = EROSION CONTROL BLANKET
- = PERIMETER EROSION BARRIER
- = INLET PIPE PROTECTION
- = RIP RAP
- = TREE TRUNK PROTECTION
- = TURF REINFORCEMENT MAT
- = ARTICULATED BLOCK MAT

FILE NAME =	USER NAME = cushmanbw	DESIGNED -	REVISED -
ct\pw_work\FWIDOT\CUSHMANBW\dms34123\dms34123.dgn	6486er.dgn	DRAWN -	REVISED -
PLOT SCALE = 20.0000' / IN.	CHECKED -	REVISED -	REVISED -
PLOT DATE = Fri May 01 08:01:46 2009	DATE -	REVISED -	REVISED -

**STATE OF ILLINOIS
DEPARTMENT OF TRANSPORTATION**

EROSION CONTROL

SCALE: SHEET NO. OF SHEETS STA. TO STA.

F.A.P. RTE.	SECTION	COUNTY	TOTAL SHEETS	SHEET NO.
742	37R-3	OGLE	345	124
CONTRACT NO. 84788				
FED. ROAD DIST. NO. ILLINOIS FED. AID PROJECT				

EROSION CONTROL

SEEDING DETAIL
STA. 603+07.85 TO 684+00

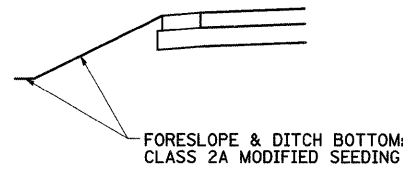

SEEDING DETAIL
LT STA. 675+50 TO 678+00
LT & RT STA. 68+00 TO 69+50 (STRONGHOLD ENT)

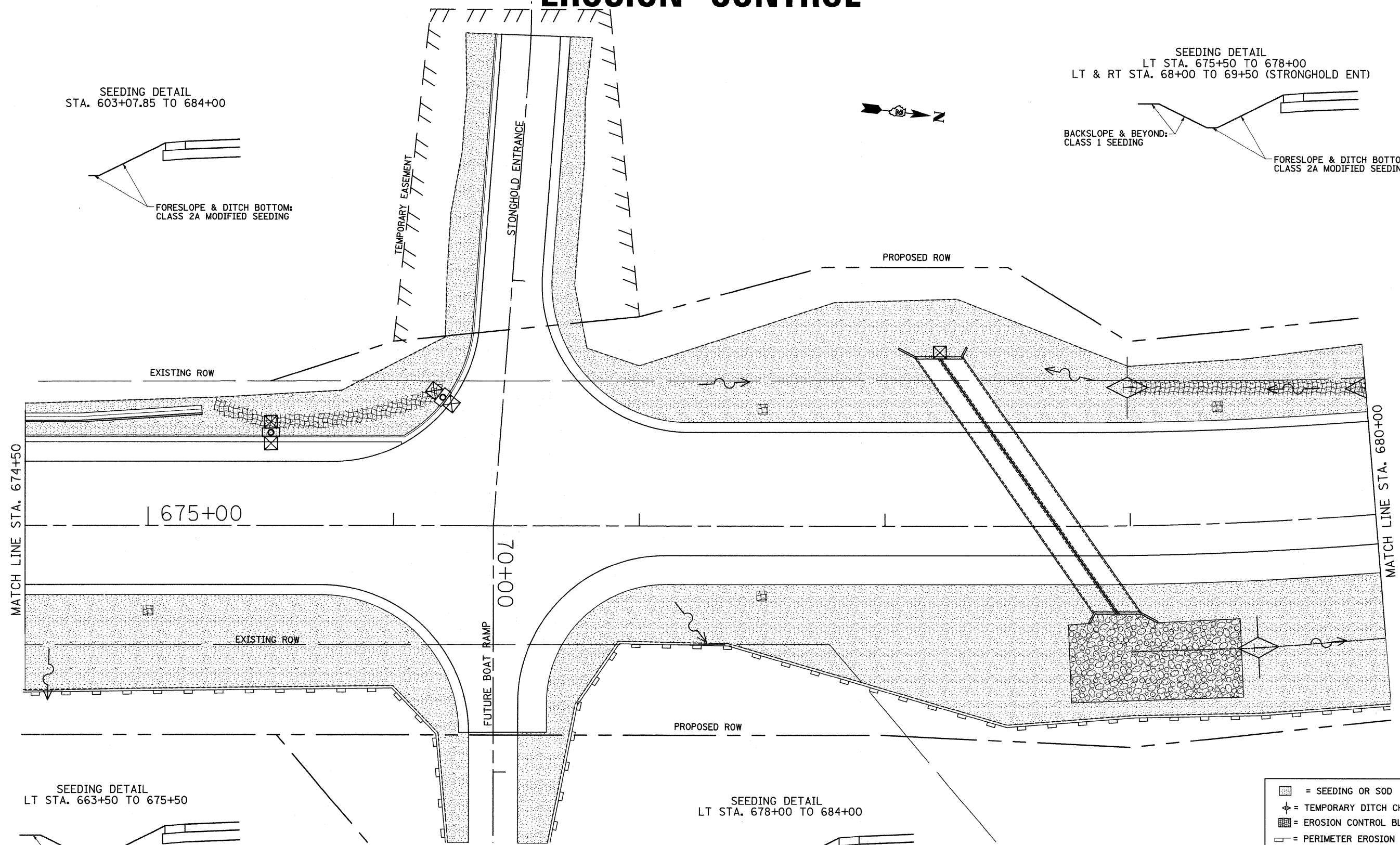
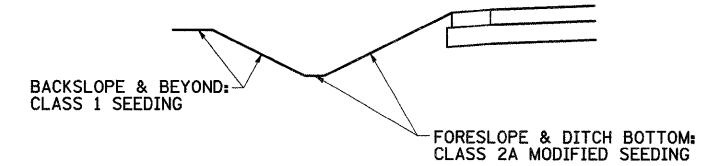

SEEDING DETAIL
LT STA. 663+50 TO 675+50

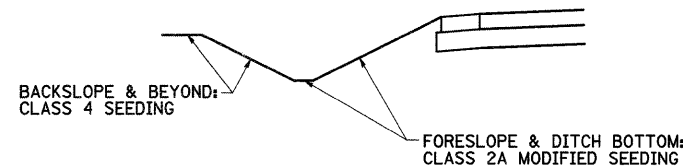

SEEDING DETAIL
LT STA. 678+00 TO 684+00

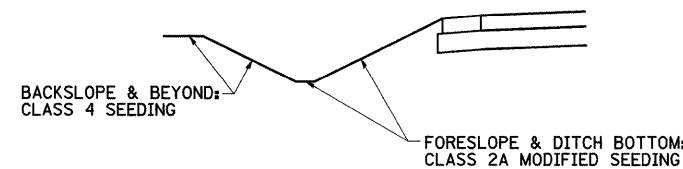

- = SEEDING OR SOD
- = TEMPORARY DITCH CHECKS
- = EROSION CONTROL BLANKET
- = PERIMETER EROSION BARRIER
- = INLET PIPE PROTECTION
- = RIP RAP
- = TREE TRUNK PROTECTION
- = TURF REINFORCEMENT MAT
- = ARTICULATED BLOCK MAT

FILE NAME =	USER NAME = cushmanbw	DESIGNED -	REVISED -
c:\pwork\FWIDOT\CUSHMANBW\dms34123\dms34123.dwg		DRAWN -	REVISED -
		CHECKED -	REVISED -
		DATE -	REVISED -

STATE OF ILLINOIS
DEPARTMENT OF TRANSPORTATION

EROSION CONTROL

SCALE: SHEET NO. OF SHEETS STA. TO STA.

F.A.P. RTE.	SECTION	COUNTY	TOTAL SHEETS	SHEET NO.
742	37R-3	OGLE	345	125
CONTRACT NO. 84788				
FED. ROAD DIST. NO. ILLINOIS FED. AID PROJECT				

EROSION CONTROL

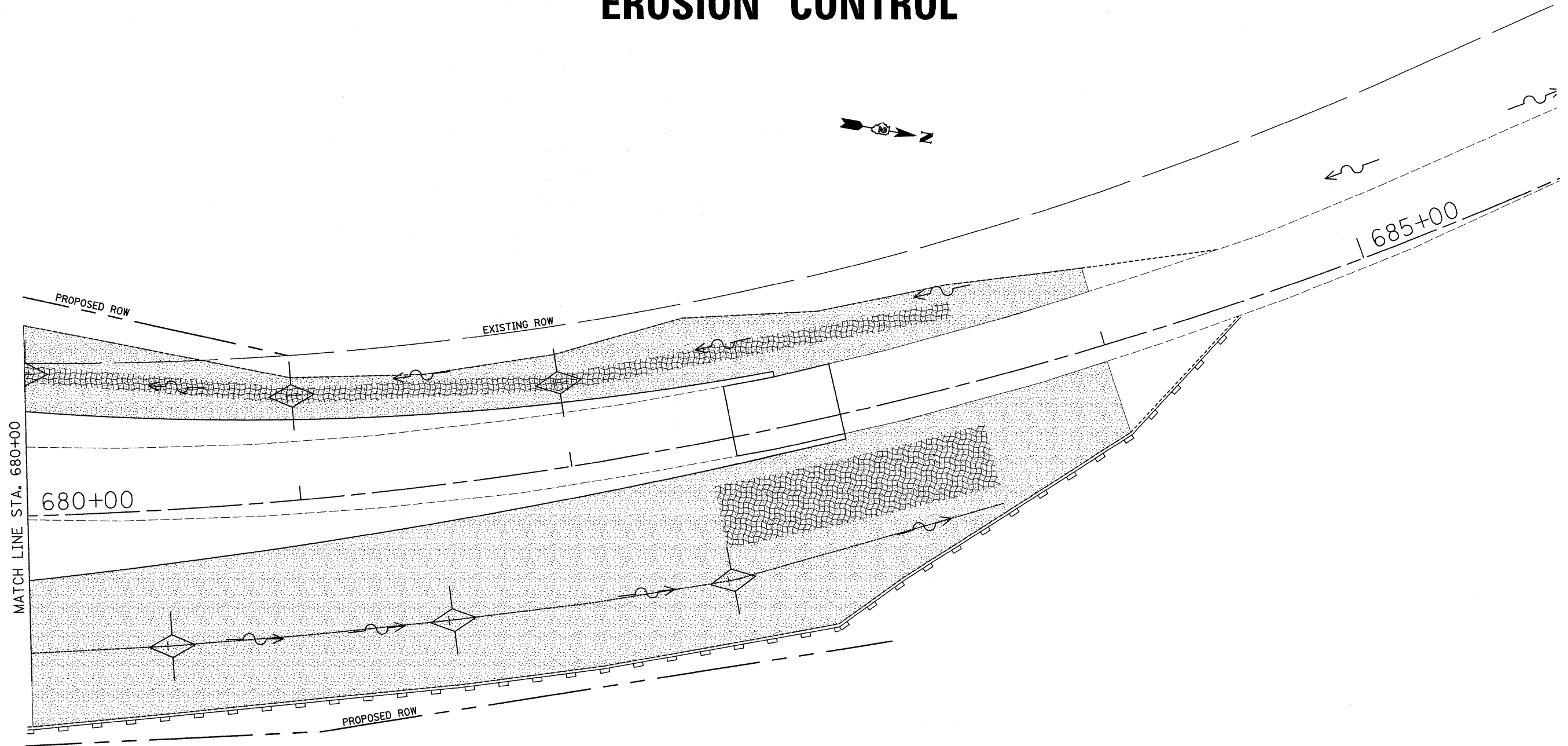

SEEDING DETAIL
STA. 603+07.85 TO 684+00

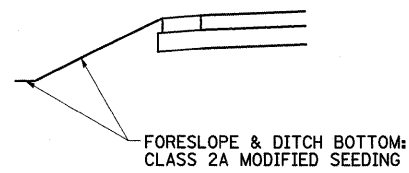

SEEDING DETAIL
LT STA. 678+00 TO 684+00

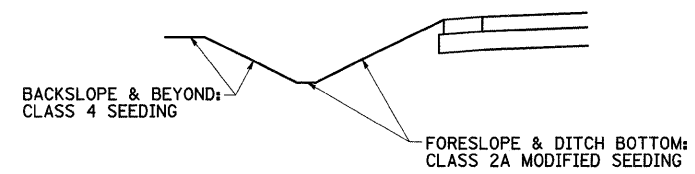

- = SEEDING OR SOD
- = TEMPORARY DITCH CHECKS
- = EROSION CONTROL BLANKET
- = PERIMETER EROSION BARRIER
- = INLET PIPE PROTECTION
- = RIP RAP
- = TREE TRUNK PROTECTION
- = TURF REINFORCEMENT MAT
- = ARTICULATED BLOCK MAT

FILE NAME =	USER NAME = cushmanbw	DESIGNED -	REVISED -
c:\pw_work\PWIDOT\CUSHMANBW\dms34123\066488er.dgn		DRAWN -	REVISED -
	PLOT SCALE = 20.0000' / IN.	CHECKED -	REVISED -
	PLOT DATE = Fri May 01 08:01:57 2009	DATE -	REVISED -

STATE OF ILLINOIS
DEPARTMENT OF TRANSPORTATION

EROSION CONTROL

SCALE: SHEET NO. OF SHEETS STA. TO STA.

F.A.P. RTE.	SECTION	COUNTY	TOTAL SHEETS	SHEET NO.
742	37R-3	OGLE	345	126
FED. ROAD DIST. NO. ILLINOIS FED. AID PROJECT			CONTRACT NO. 84788	

DRAINAGE DETAILS

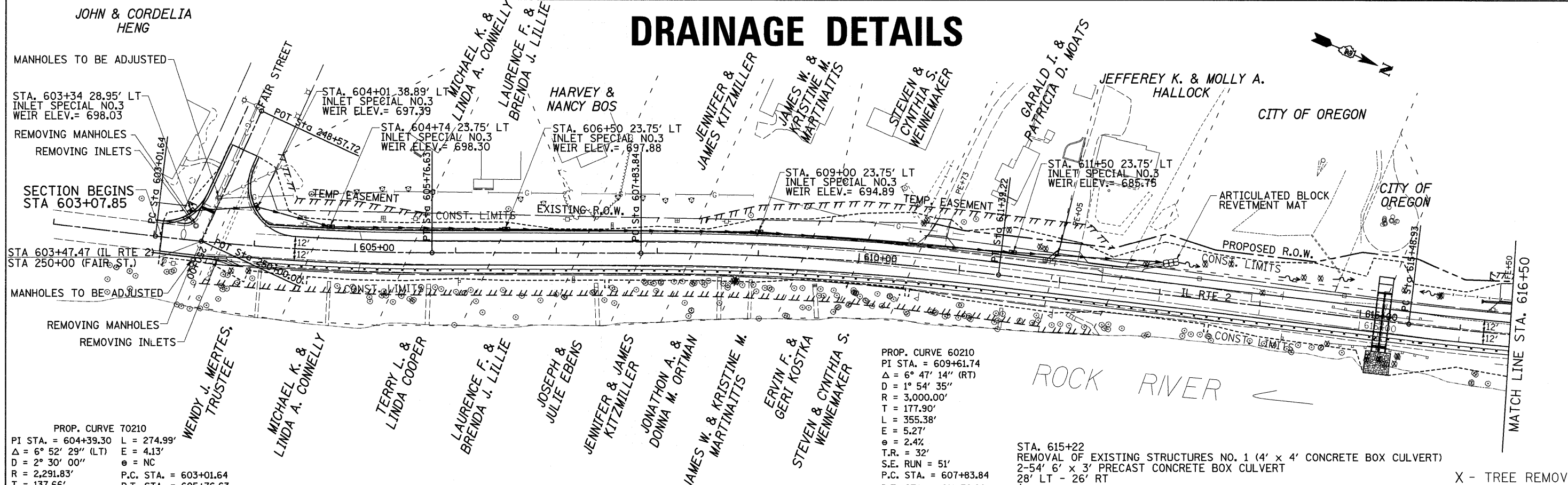

PROP. CURVE 70210
 PI STA. = 604+39.30 L = 274.99'
 $\Delta = 6^\circ 52' 29''$ (LT) E = 4.13'
 D = 2° 30' 00" e = NC
 R = 2,291.83' P.C. STA. = 603+01.64
 T = 137.66' P.T. STA. = 605+76.63

PROP. CURVE 60210
 PI STA. = 609+61.74
 $\Delta = 6^\circ 47' 14''$ (RT)
 D = 1° 54' 35"
 R = 3,000.00'
 T = 177.90'
 L = 355.38'
 E = 5.27'
 e = 2.4%
 T.R. = 32'
 S.E. RUN = 51'
 P.C. STA. = 607+83.84
 P.T. STA. = 611+39.22

STA. 615+22
 REMOVAL OF EXISTING STRUCTURES NO. 1 (4' x 4' CONCRETE BOX CULVERT)
 2-54' 6" x 3' PRECAST CONCRETE BOX CULVERT
 28' LT - 26' RT
 ∇ 673.70 - 673.31 @ 0.72%
 1 EA. DROP BOX NO.1 LT
 2 EA. 6' x 3' PRECAST CONCRETE BOX CULVERT END SECTIONS RT

X - TREE REMOVAL

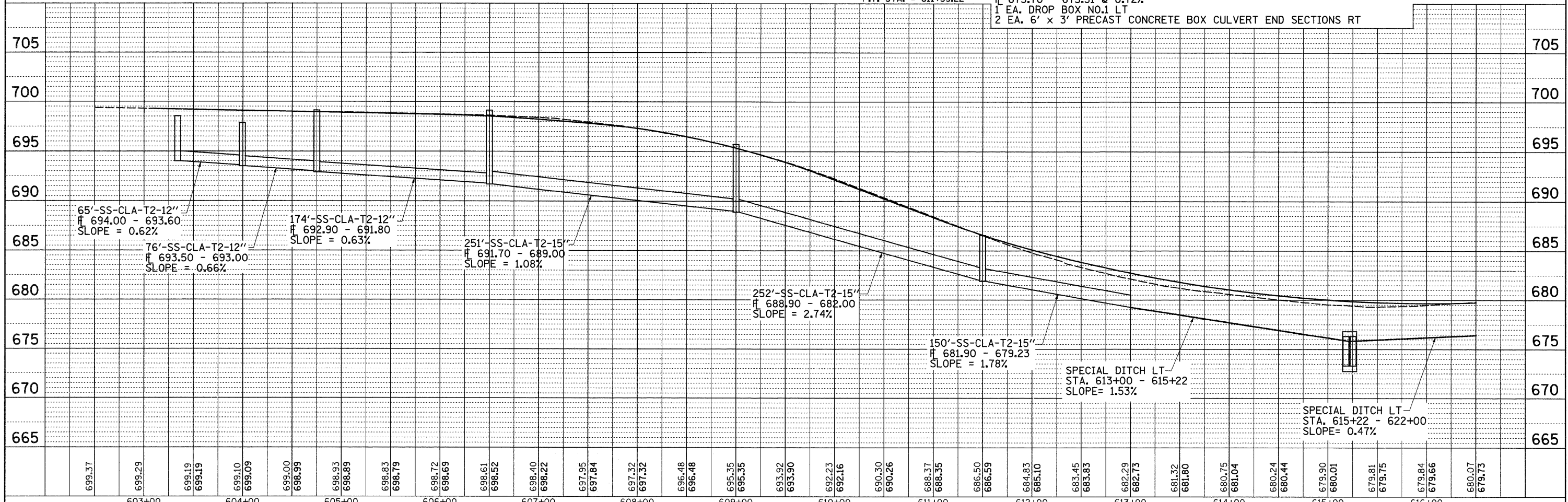

FILE NAME =	USER NAME = cushmanbw	DESIGNED -	REVISED -	STATE OF ILLINOIS DEPARTMENT OF TRANSPORTATION	DRAINAGE DETAILS	F.A.P. RTE. =	SECTION	COUNTY	TOTAL SHEETS	SHEET NO.
os:\pw_work\VP\WIDOT\CUSHMANBW\dms34123\d08486dr.Ldgn		DRAWN -	REVISED -			742	37R-3	OGLE	345	127
PLOT SCALE = 50.0000' / IN.		CHECKED -	REVISED -			CONTRACT NO. 84788				
PLOT DATE = Fri May 01 08:08:27 2009		DATE	REVISED			FED. ROAD DIST. NO. ILLINOIS FED. AID PROJECT				

PLAN	BY	DATE
SURVEYED		
CONFORM		
CHECKED		
PI. OF WAY CHECKED		
CADD FILE NAME		

PROFILE	BY	DATE
SURVEYED		
NOTED		
CHECKED		
BLM NOTED		
STRUCTURE NOTATIONS CHKD		

DRAINAGE DETAILS

EDWARD BENDIS

JOSEPH & JULIE EBENS

DENNIS R. & LAURIE WASIKOWSKI

HARRY E. & KARLY-K. SPELL

RUDOLF & JOYCE SIEBEL

SEPTIC FIELD
 STA 19+44 @ 28°38'24"
 146' PCUL, T1, CORR. STEEL, EORS 30"
 64'-6" LT - 81'-6" RT
 H 679.41 - 675.56 @ 2.63%
 1 EA. METAL END SEC, 30" EQUIV. ROUND SIZE

STA. 616+50 31' LT
 52' P CUL, CL D, T1, 15"
 2 EA. END SECTIONS, 15"
 TEMP. EASEMENT

STA. 618+56 32' LT
 46' P CUL, CL D, T1, 15"
 2 EA. END SECTIONS, 15"
 TEMP. EASEMENT

STA. 618+62
 REMOVAL OF EXISING STRUCTURES NO.8
 24" CMP W/DROP STRUCTURE

PROP. CURVE 60220
 PI STA. = 617+80.75
 $\Delta = 8^\circ 50' 14''$ (LT)
 $D = 1^\circ 54' 35''$
 $R = 3,000.00'$
 $T = 231.82'$
 $L = 462.72'$
 $E = 8.94'$
 $e = 3.4\%$
 $T.R. = 37'$
 $S.E. RUN = 84'$
 $P.C. STA. = 615+48.93$
 $P.T. STA. = 620+11.65$

IL RTE 2
 PROP. CURVE 70240
 PI STA. = 629+83.82
 $\Delta = 10^\circ 14' 28.7923''$ (RT)
 $D = 2^\circ 17' 30.5922''$
 $R = 2,500.0000'$
 $T = 224.0280'$
 $L = 446.8624'$
 $E = 10.0176'$
 $e = 3.8\%$
 $P.C.T.R. = 36'$
 $P.C.S.E. RUN = 138'$
 $P.T.S.E. RUN = 178'$ ROTATION AT STA. 633+25.63
 $P.C. STA. = 627+59.79$
 $P.T. STA. = 632+06.65$

STA. 626+61
 REMOVAL OF EXISTING STRUCTURES NO. 2 (10' x 6' CONCRETE BOX CULVERT)
 79' 7' x 4' PRECAST CONCRETE BOX CULVERT
 45' LT - 34' RT
 $H = 674.56 - 673.97 @ 0.75\%$
 1 EA. DROP BOX NO.2 LT
 1 EA. BOX CULVERT END SECTION CULVERT NO.1 RT

BOTANICAL AREA
 STA 626+50 RT TO STA 637+00 RT

X - TREE REMOVAL

PLAN	BY	DATE
SURVEYED		
DESIGNED		
CHECKED		
NOTED		
NO.		

PROFILE	BY	DATE
SURVEYED		
DESIGNED		
CHECKED		
NOTED		
NO.		

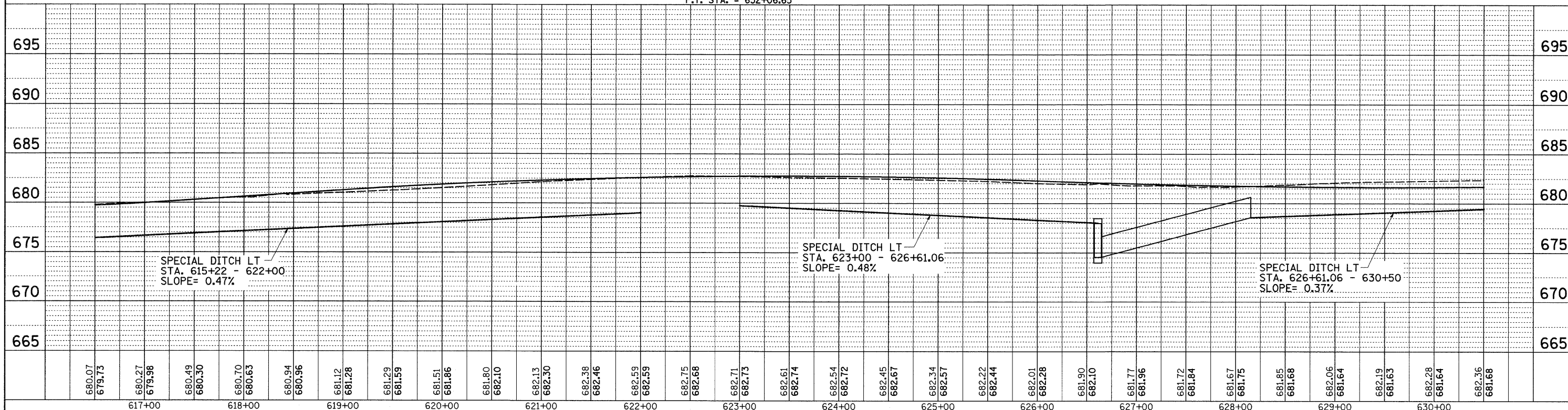

FILE NAME =	USER NAME = cushmanbw	DESIGNED -	REVISED -	STATE OF ILLINOIS DEPARTMENT OF TRANSPORTATION	DRAINAGE DETAILS	F.A.P. RTE.	SECTION	COUNTY	TOTAL SHEETS	SHEET NO.
DESIGNED -	DRAWN -	REVISED -	742			37R-3	OGLE	345	128	
PLOT SCALE = 50.0000' / IN.	CHECKED -	REVISED -	CONTRACT NO. 84788							
PLOT DATE = Fri May 01 08:08:29 2009	DATE -	REVISED -	ILLINOIS FED. AID PROJECT							

DRAINAGE DETAILS



PLAN	SURVEYED	BY	DATE
	NOTED		
	CHECKED		
	BY		
	NO. OF WAY CHECKED		
	NO.		
	CADD FILE NAME		

PROFILE	SURVEYED	BY	DATE
	NOTED		
	CHECKED		
	BY		
	NO. OF WAY CHECKED		
	NO.		
	STRUCTURE NOTATIONS CRKD		

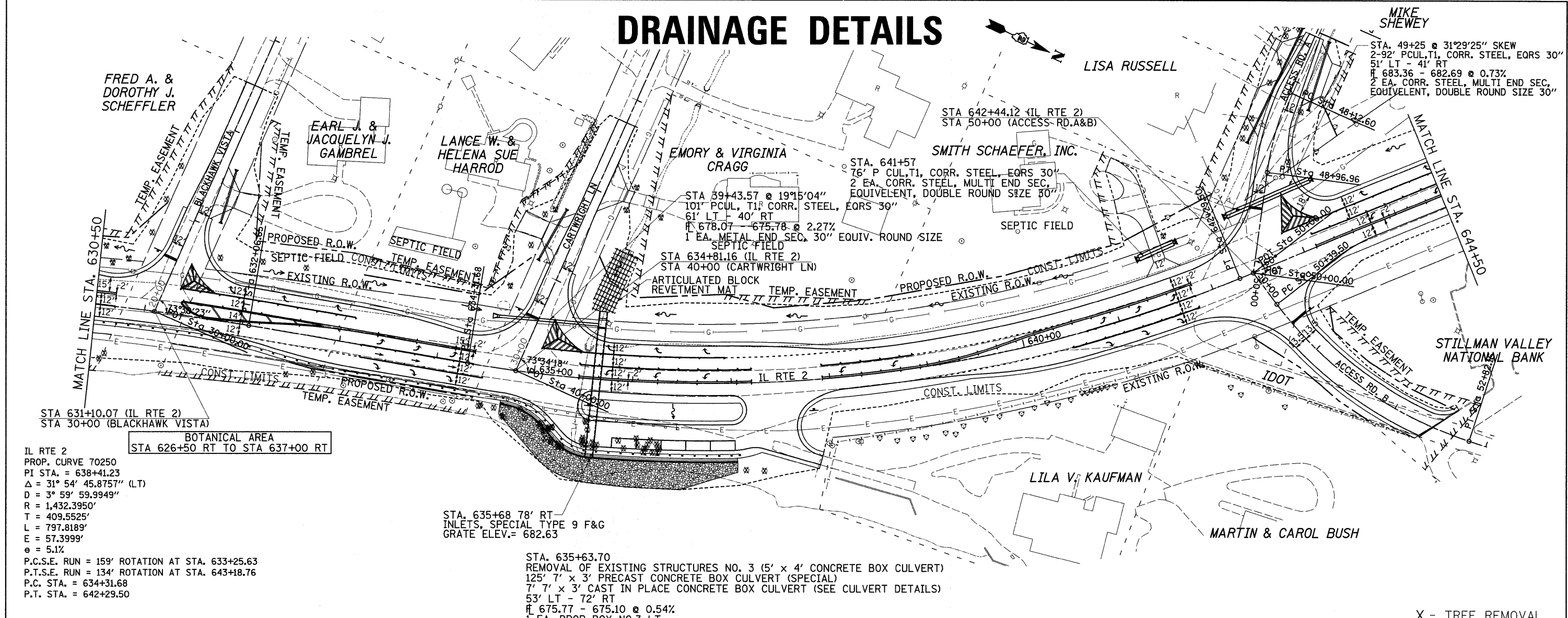

IL RTE 2
 PROP. CURVE 70250
 PI STA. = 638+41.23
 $\Delta = 31^\circ 54' 45.8757''$ (LT)
 $D = 3^\circ 59' 59.9949''$
 $R = 1,432.3950'$
 $T = 409.5525'$
 $L = 797.8189'$
 $E = 57.3999'$
 $e = 5.1\%$
 P.C.S.E. RUN = 159' ROTATION AT STA. 633+25.63
 P.T.S.E. RUN = 134' ROTATION AT STA. 643+18.76
 P.C. STA. = 634+31.68
 P.T. STA. = 642+29.50

STA. 635+68.78' RT
 INLETS, SPECIAL TYPE 9 F&G
 GRATE ELEV.= 682.63

STA. 635+63.70
 REMOVAL OF EXISTING STRUCTURES NO. 3 (5' x 4' CONCRETE BOX CULVERT)
 125' 7' x 3' PRECAST CONCRETE BOX CULVERT (SPECIAL)
 7' 7' x 3' CAST IN PLACE CONCRETE BOX CULVERT (SEE CULVERT DETAILS)
 53' LT - 72' RT
 $\text{H} = 675.77 - 675.10 @ 0.54\%$
 1 EA. DROP BOX NO.3 LT

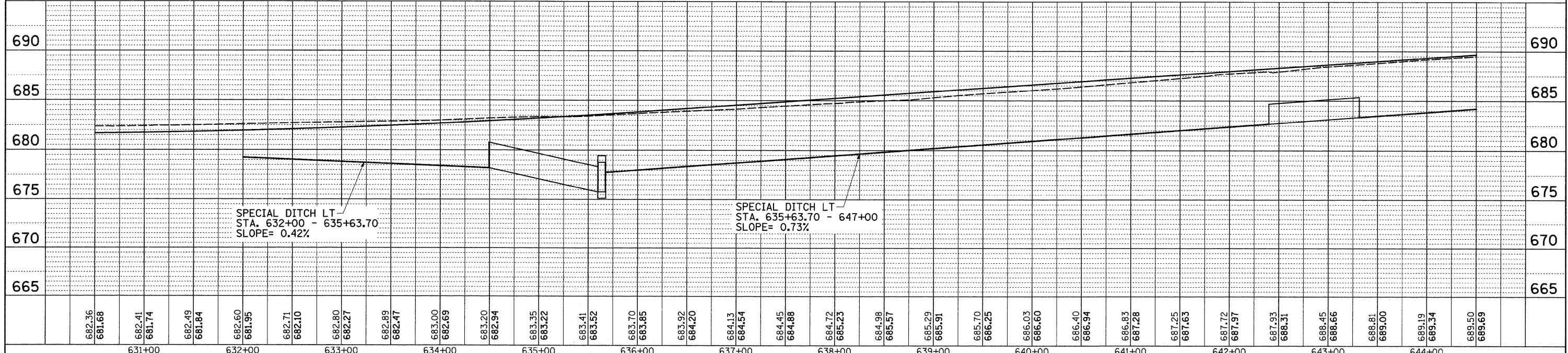

FILE NAME =	USER NAME = cushmanbw	DESIGNED -	REVISED -	F.A.P. RTE.	SECTION	COUNTY	TOTAL SHEETS	SHEET NO.
c:\pw_work\PIWIDOT\CUSHMANBW\dms34123\0808086dr-L.dgn		DRAWN -	REVISED -	742	37R-3	OGLE	345	129
PLOT SCALE = 50.0000' / IN.	CHECKED -	REVISED -	SCALE:	SHEET NO.	OF	SHEETS	STA.	TO STA.
PLOT DATE = Fri May 01 08:08:30 2009	DATE -	REVISED -						
							CONTRACT NO. 84788	
							FED. ROAD DIST. NO. ILLINOIS FED. AID PROJECT	

STATE OF ILLINOIS
 DEPARTMENT OF TRANSPORTATION

DRAINAGE DETAILS

X - TREE REMOVAL

DRAINAGE DETAILS

DALLAS A. HUNTLEY

TEMP. EASEMENT
LEAVE EXISTING CMP

STA. 651+36 56' LT
58' P CUL, CL D, T1, 15"
2 EA. END SECTIONS, 15"

WILLIAM R. &
DOROTHY CULTRA

EXISTING 12" DRAIN TILE

PRESBYTERY OF BLACKHAWK

PROPOSED R.O.W.

TEMP EASEMENT

EXISTING R.O.W.

CONST. LIMITS

CONST. LIMITS

EXISTING R.O.W.

CONST. LIMITS

EXISTING R.O.W.

CONST. LIMITS

EXISTING R.O.W.

CONST. LIMITS

EXISTING R.O.W.

CONST. LIMITS

EXISTING R.O.W.

CONST. LIMITS

EXISTING R.O.W.

CONST. LIMITS

EXISTING R.O.W.

CONST. LIMITS

EXISTING R.O.W.

CONST. LIMITS

EXISTING R.O.W.

CONST. LIMITS

EXISTING R.O.W.

CONST. LIMITS

EXISTING R.O.W.

CONST. LIMITS

EXISTING R.O.W.

CONST. LIMITS

EXISTING R.O.W.

CONST. LIMITS

EXISTING R.O.W.

CONST. LIMITS

EXISTING R.O.W.

CONST. LIMITS

EXISTING R.O.W.

CONST. LIMITS

EXISTING R.O.W.

CONST. LIMITS

EXISTING R.O.W.

CONST. LIMITS

EXISTING R.O.W.

CONST. LIMITS

EXISTING R.O.W.

CONST. LIMITS

EXISTING R.O.W.

CONST. LIMITS

EXISTING R.O.W.

CONST. LIMITS

EXISTING R.O.W.

CONST. LIMITS

EXISTING R.O.W.

CONST. LIMITS

EXISTING R.O.W.

CONST. LIMITS

EXISTING R.O.W.

CONST. LIMITS

EXISTING R.O.W.

CONST. LIMITS

STILLMAN VALLEY
NATIONAL BANK

IL RTE 2
PROP. CURVE 70260
PI STA. = 650+08.08
 $\Delta = 40^\circ 47' 29''$ (RT)
D = 4° 00' 00"
R = 1,432.39'
T = 532.58'
L = 1,019.78'
E = 95.80'
 $\theta = 5.6\%$
P.C.S.E. RUN = 235' ROTATION AT STA. 643+18.76
P.T.T.R. = 30'
P.T.S.E. RUN = 216'
P.C. STA. = 644+75.50
P.T. STA. = 654+95.28

PADDLE WHEEL INN LLC

TOSHIO NAKAJIMA

WILLIAM R. &
DOROTHY CULTRA

STA. 654+30
REMOVAL OF EXISTING STRUCTURE NO. 4
(7' x 2.5' CONCRETE BOX CULVERT)
2-74' PRECAST -CLA-T2-EQRS 24"
44.5' LT - 28.5' RT
R 690.51 - 689.96 @ 0.75%
2 EA. PRECAST FLARED END SECTION ELLIPTICAL, EQRS-24" RT
1 DROPBOX, NO.4 LT
PRECAST BOX SHALL CONFORM TO THE REQUIREMENTS OF AASHTO M273 f min < 2'

Drainage Area = 54 Ac				
Existing Low Grade Elevation:		694.62	ft. @ Sta 654+26	
Proposed Low Grade Elevation:		694.64	ft. @ Sta 654+26	
Flood	Frequency	Discharge	Headwater Elev. (ft)	
	Year	cfs	Existing	Proposed
Ten-Year	10	26	694.56	695.17
Design	50	36	694.61	695.32
Base	100	44	694.64	695.43
Max. Calc.	500	59	694.70	695.82

10-Year Velocity through Existing Culvert = 7.9 fps
10-Year Velocity through Proposed Culvert = 6.7 fps

X - TREE REMOVAL

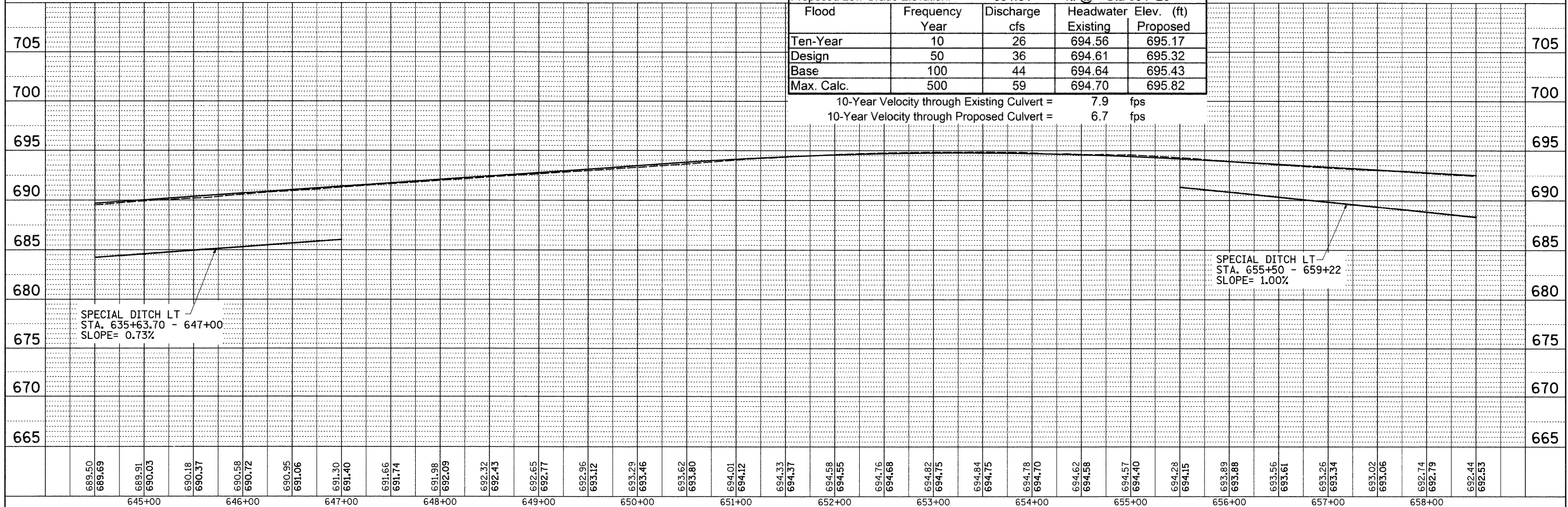

FILE NAME =	USER NAME = cushmanbw	DESIGNED -	REVISED -	F.A.P. RTE. 742	SECTION 37R-3	COUNTY OGLE	TOTAL SHEETS 345	SHEET NO. 130
CONTRACT NO. 84788	CONTRACT NO. 84788	CONTRACT NO. 84788	CONTRACT NO. 84788	CONTRACT NO. 84788	CONTRACT NO. 84788	CONTRACT NO. 84788	CONTRACT NO. 84788	CONTRACT NO. 84788

STATE OF ILLINOIS
DEPARTMENT OF TRANSPORTATION

DRAINAGE DETAILS

SCALE: SHEET NO. OF SHEETS STA. TO STA.

FED. ROAD DIST. NO. ILLINOIS FED. AID PROJECT

PLAN	BY	DATE
SURVEYED		
ALIGNED		
CHECKED		
INT. OF WAY		
NO.		
CADD FILE NAME		

PROFILE	BY	DATE
SURVEYED		
PLotted		
CHECKED		
BY		
NO.		
STRUCTURE NOTATIONS CHKD		

DRAINAGE DETAILS

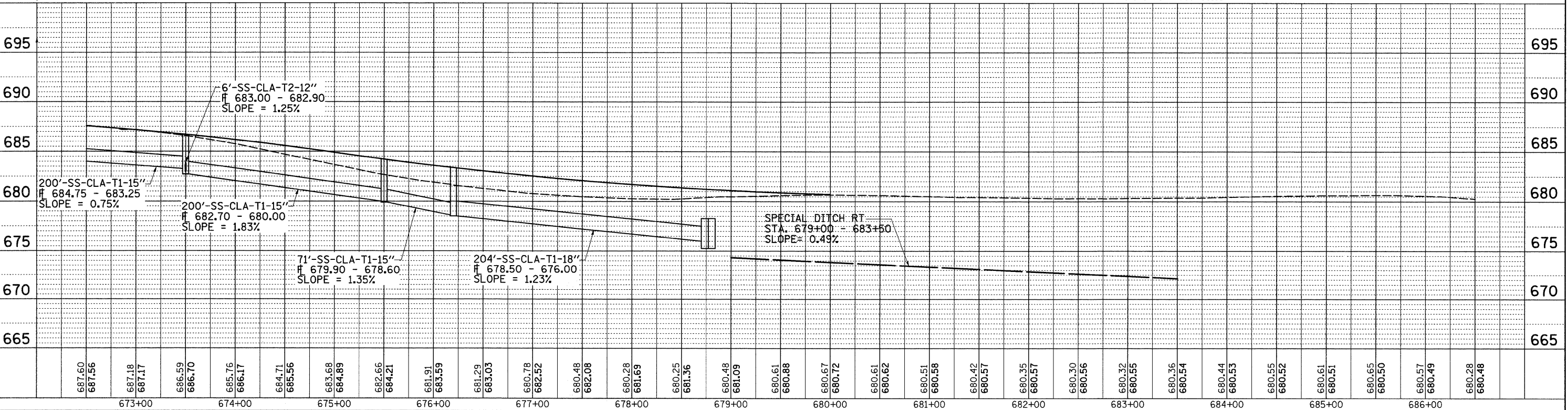
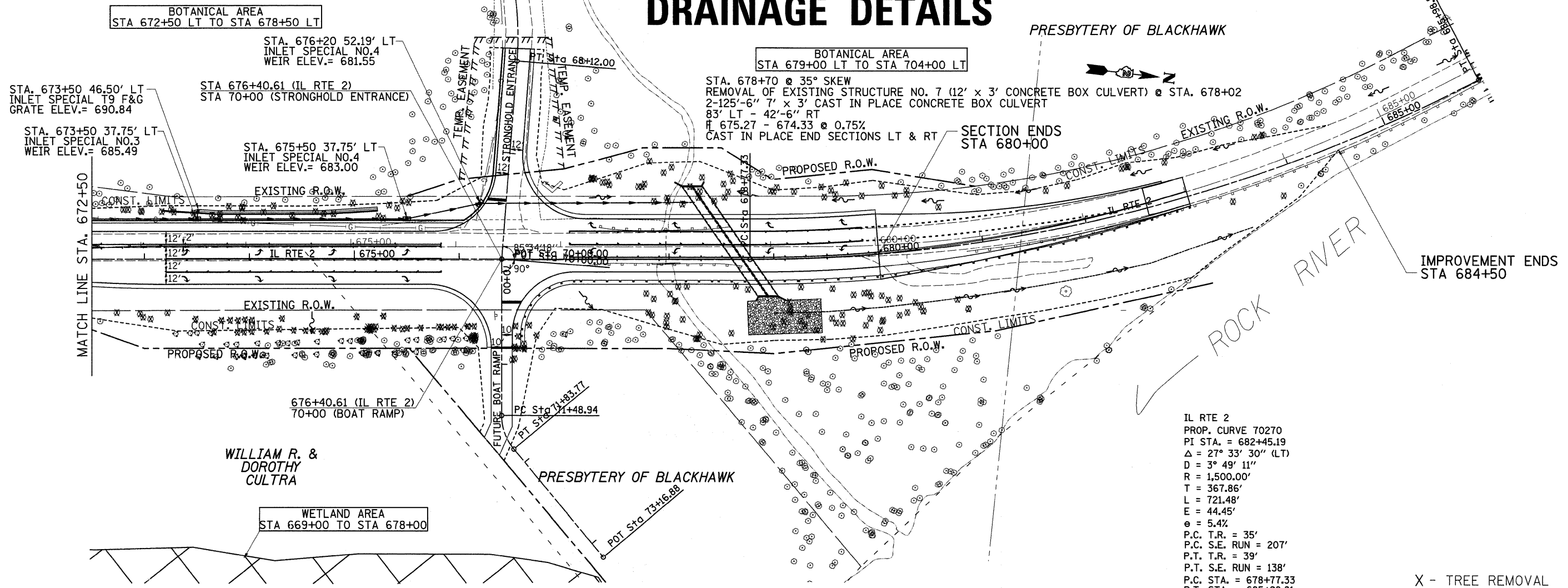

FILE NAME =	USER NAME = cushmanbw	DESIGNED -	REVISED -	STATE OF ILLINOIS DEPARTMENT OF TRANSPORTATION		DRAINAGE DETAILS		F.A.P. RTE. =	SECTION	COUNTY	TOTAL SHEETS	SHEET NO.
ca:\pw_work\PIWIDOT\CUSHMANBW\dms34123\d86486dr1.dgn		DRAWN -	REVISED -					742	37R-3	OGLE	345	132
PLOT SCALE = 50.0000' / IN.		CHECKED -	REVISED -					CONTRACT NO. 84788				
PLOT DATE = Fri May 01 08:08:38 2009		DATE	REVISED					ILLINOIS FED. AID PROJECT				

BY	DATE
PLAN	
SURVEYED	
ALIGNED	
CHECKED	
REVISION	
NO.	

BY	DATE
PROFILE	
SURVEYED	
ALIGNED	
CHECKED	
REVISION	
NO.	

PAVEMENT MARKING, R.O.W. & EASEMENT

POLYUREA PAVEMENT MARKING
TYPE 1 - LINE 4" (YELLOW)

POLYUREA PAVEMENT MARKING
TYPE 1 - LINE 4" (WHITE)
STA 249+00 - 249+57 LT
STA 249+00 - 250+00 RT

POLYUREA PAVEMENT MARKING
TYPE 1 - LINE 24" (WHITE)
STA. 249+70

NOTE: ALL LETTERS & SYMBOLS ARE POLYUREA.

URETHANE PAVEMENT MARKING
LINE 4" (DOUBLE YELLOW)
STA. 604+21 - STA. 620+42

URETHANE PAVEMENT MARKING
LINE 4" (WHITE)
STA. 604+40 - 620+42

URETHANE PAVEMENT MARKING
LINE 4" (DOUBLE YELLOW)
STA. 604+21 - STA. 620+42

URETHANE PAVEMENT MARKING
LINE 4" (WHITE)
STA. 604+40 - 620+42

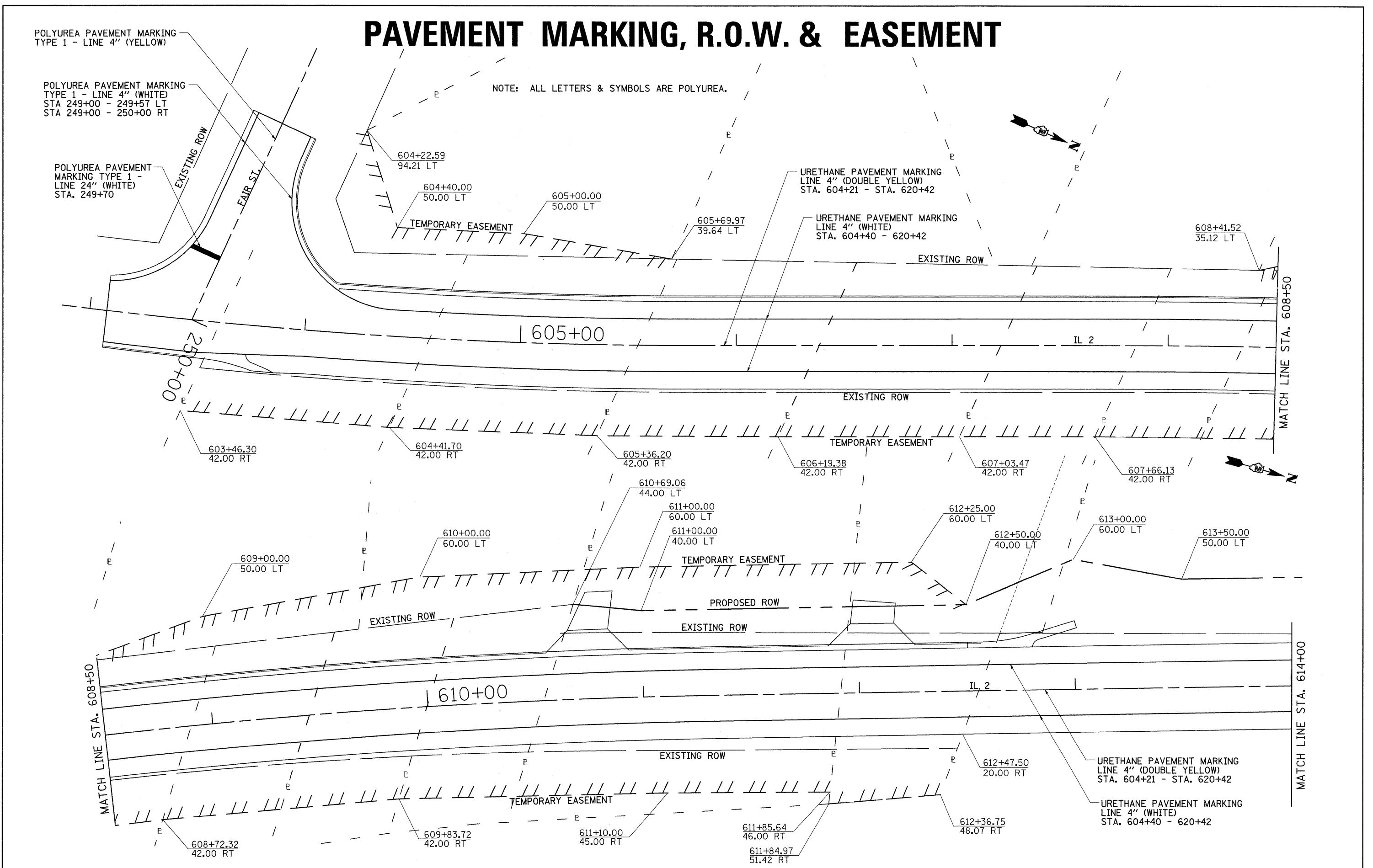

FILE NAME =	USER NAME = cushmanbw	DESIGNED -	REVISED -	STATE OF ILLINOIS DEPARTMENT OF TRANSPORTATION	PAVEMENT MARKING, R.O.W. & EASEMENT	F.A.P. RTE.	SECTION	COUNTY	TOTAL SHEETS	SHEET NO.	
cr:\pw_work\PWIDOT\CUSHMANBW\dms34123\g6486pmk.dgn	PLOT SCALE = 20,000' / IN.	DRAWN -	REVISED -			742	37R-3	OGLE	345	133	
	PLOT DATE = Fri May 01 08:13:34 2009	CHECKED -	REVISED -			CONTRACT NO. 84788					
		DATE -	REVISED -			SCALE:	SHEET NO.	OF	SHEETS	STA.	TO STA.

PAVEMENT MARKING, R.O.W. & EASEMENT

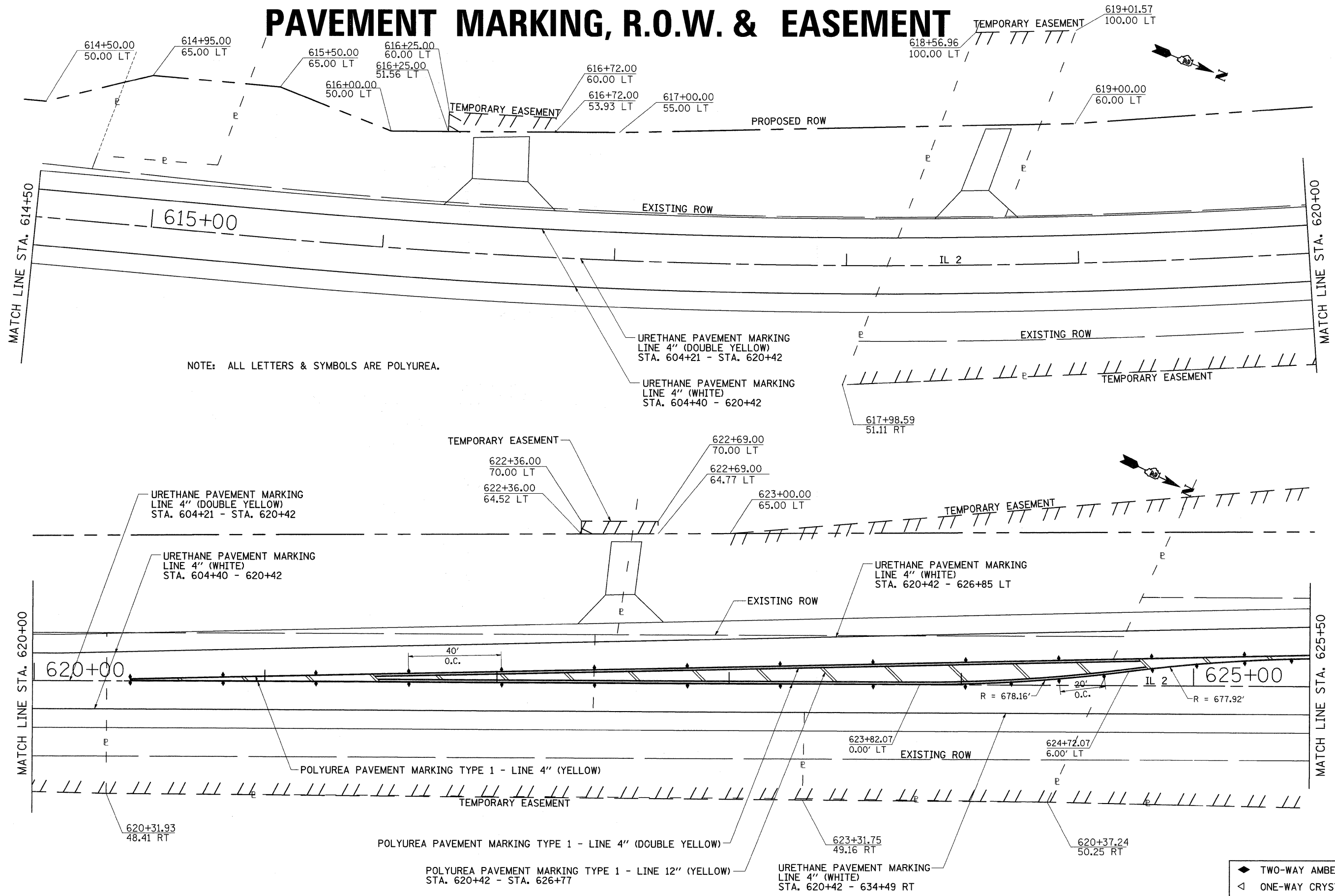

NOTE: ALL LETTERS & SYMBOLS ARE POLYUREA.

◆ TWO-WAY AMBER
◁ ONE-WAY CRYSTAL

FILE NAME =	USER NAME = cushmanbw	DESIGNED -	REVISED -	STATE OF ILLINOIS DEPARTMENT OF TRANSPORTATION	PAVEMENT MARKING, R.O.W. & EASEMENT	F.A.P. RTE.	SECTION	COUNTY	TOTAL SHEETS	SHEET NO.
ct:\pwork\PWIDOT\CUSHMANBW\dms34123\dms34123.dwg	6486pmk.dgn	DRAWN -	REVISED -			742	37R-3	OGLE	345	134
PLOT SCALE = 28.0000' / IN.	CHECKED -	REVISED -	REVISED -			CONTRACT NO. 84788				
PLOT DATE = Fri May 01 08:13:34 2009	DATE -	REVISED -	REVISED -			FED. ROAD DIST. NO.	ILLINOIS FED. AID PROJECT			

PAVEMENT MARKING, R.O.W. & EASEMENT

NOTE: ALL LETTERS & SYMBOLS ARE POLYUREA.

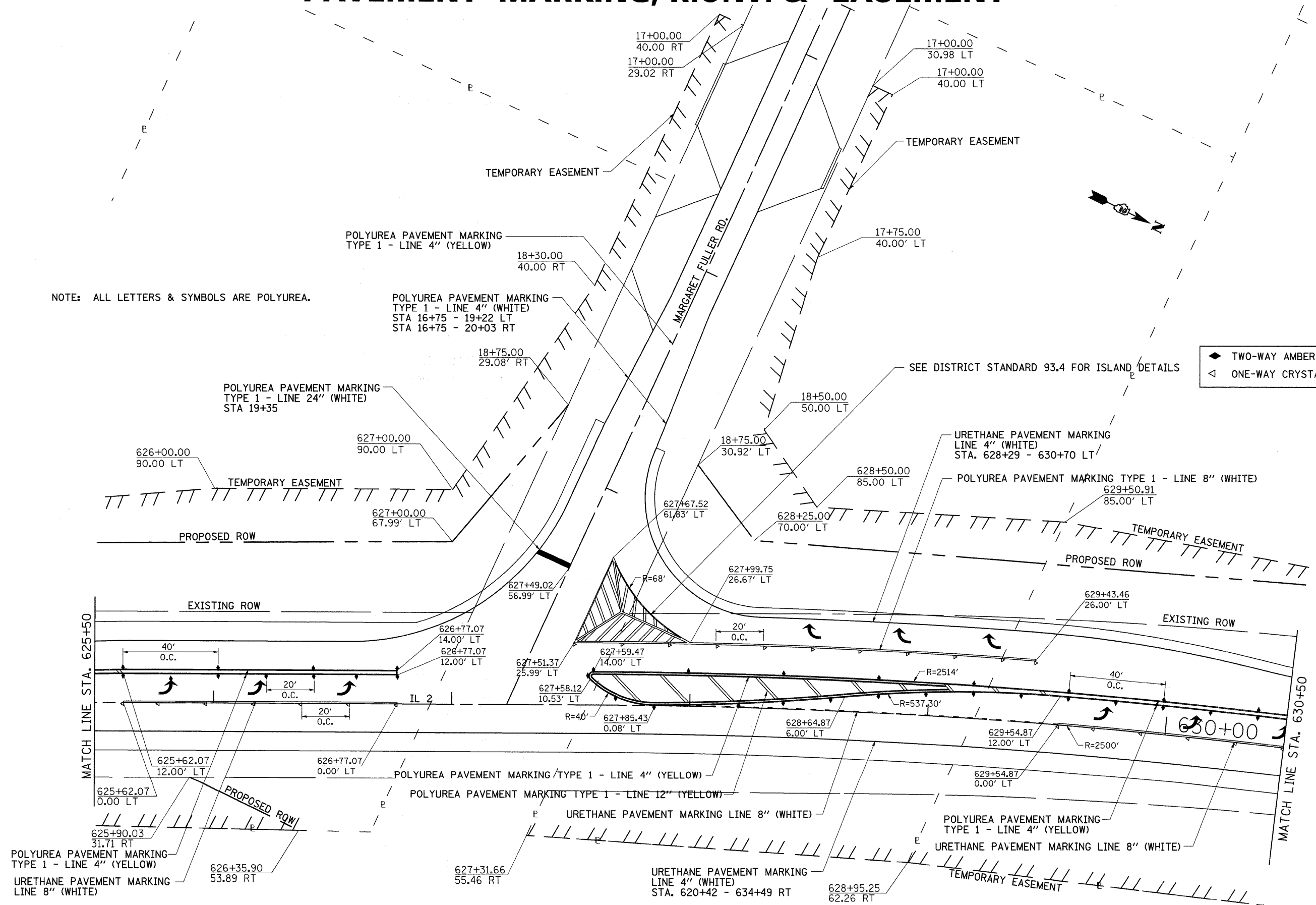

◆ TWO-WAY AMBER
◁ ONE-WAY CRYSTAL

SEE DISTRICT STANDARD 93.4 FOR ISLAND DETAILS

FILE NAME =	USER NAME = cushmanbw	DESIGNED -	REVISED -	STATE OF ILLINOIS DEPARTMENT OF TRANSPORTATION	PAVEMENT MARKING, R.O.W. & EASEMENT	F.A.P. RTE.	SECTION	COUNTY	TOTAL SHEETS	SHEET NO.
es:\pwork\PWIDOT\CUSHMANBW\dms34123\d6486pmk.dgn	DRAWN -	REVISED -	742			37R-3	OGLE	345	135	
PLOT SCALE = 20.0000' / IN.	CHECKED -	REVISED -	CONTRACT NO. 84788							
PLOT DATE = Fri May 01 08:13:33 2009	DATE -	REVISED -	FED. ROAD DIST. NO. ILLINOIS FED. AID PROJECT							
SCALE: SHEET NO. OF SHEETS STA. TO STA.										

PAVEMENT MARKING, R.O.W. & EASEMENT

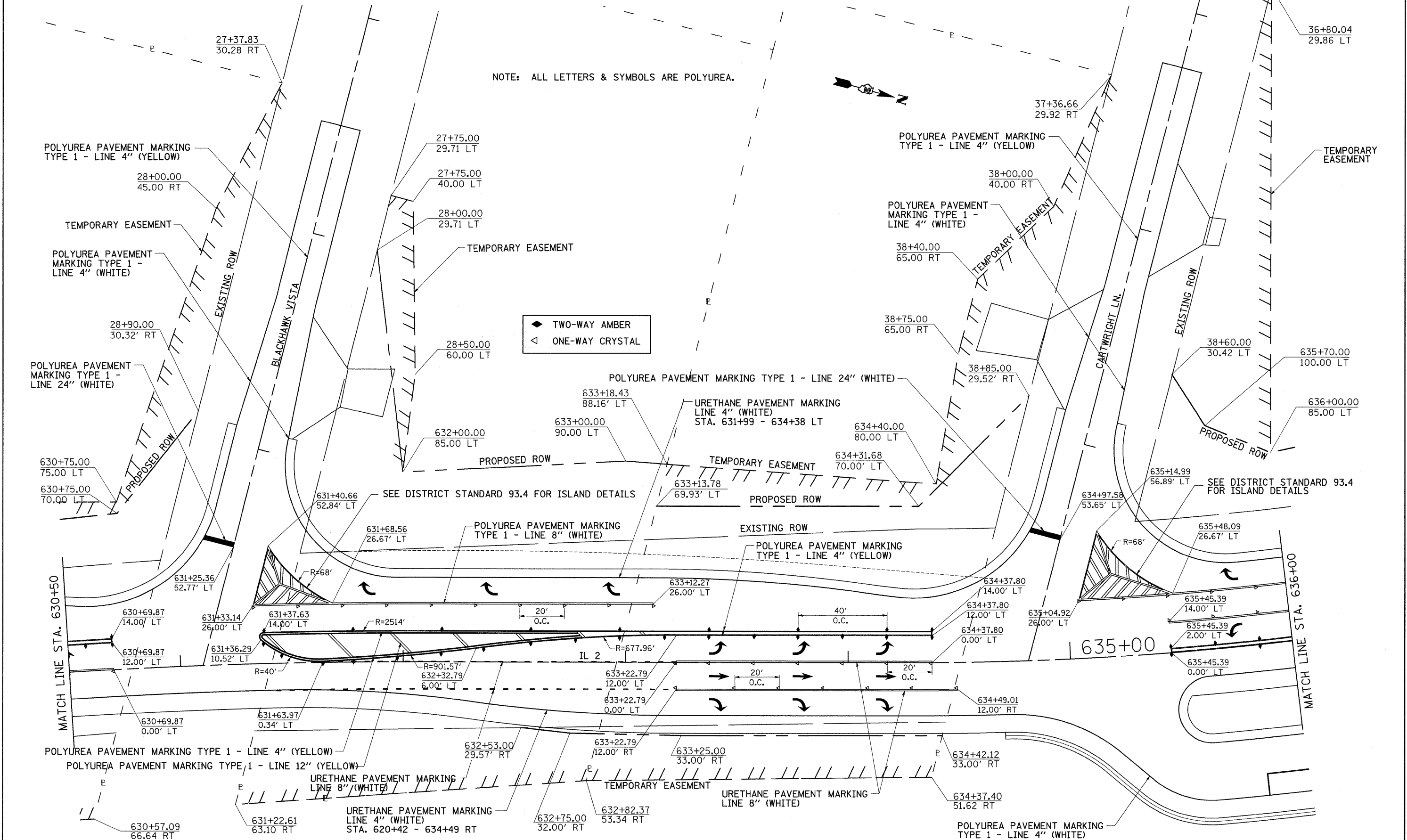

NOTE: ALL LETTERS & SYMBOLS ARE POLYUREA.

◆ TWO-WAY AMBER
◁ ONE-WAY CRYSTAL

FILE NAME =	USER NAME = cushmanbw	DESIGNED -	REVISED -	STATE OF ILLINOIS DEPARTMENT OF TRANSPORTATION	PAVEMENT MARKING, R.O.W. & EASEMENT	F.A.P. RTE.	SECTION	COUNTY	TOTAL SHEETS	SHEET NO.	
c:\pwork\p\WIDOT\CUSHMANBW\dms34123\06486pmk.dgn	PLOT SCALE = 20.0000' / IN.	DRAWN -	REVISED -			742	37R-3	OGLE	345	136	
	PLOT DATE = Fri May 01 08:13:26 2009	CHECKED -	REVISED -			CONTRACT NO. 84788					
		DATE -	REVISED -			SCALE:	SHEET NO.	OF	SHEETS	STA.	TO STA.

PAVEMENT MARKING, R.O.W. & EASEMENT

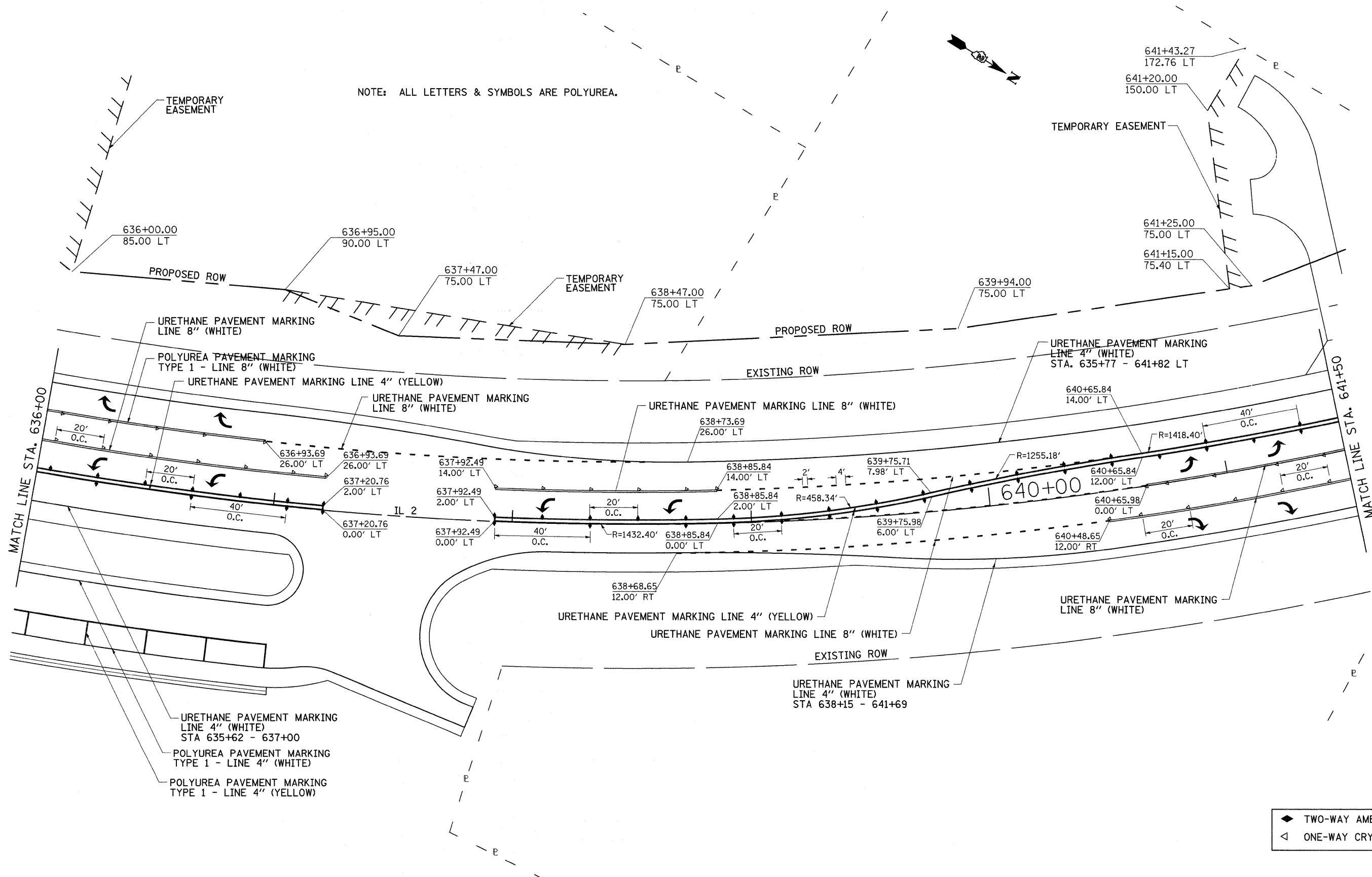

NOTE: ALL LETTERS & SYMBOLS ARE POLYUREA.

◆	TWO-WAY AMBER
◁	ONE-WAY CRYSTAL

FILE NAME =	USER NAME = cushmanbw	DESIGNED -	REVISED -	STATE OF ILLINOIS DEPARTMENT OF TRANSPORTATION	PAVEMENT MARKING, R.O.W. & EASEMENT	F.A.P. RTE.	SECTION	COUNTY	TOTAL SHEETS	SHEET NO.
ct\pw_work\PWIDOT\CUSHMANBW\dms34123\dms34123.dwg	6488pmk.dgn	DRAWN -	REVISED -			742	37R-3	OGLE	345	137
PLOT SCALE = 20.0000' / IN.	CHECKED -	REVISED -	REVISED -			CONTRACT NO. 84788				
PLOT DATE = Fri May 01 08:13:27 2009	DATE -	REVISED -	REVISED -			FED. ROAD DIST. NO. ILLINOIS FED. AID PROJECT				
SCALE:		SHEET NO. OF SHEETS		STA. TO STA.						

PAVEMENT MARKING, R.O.W. & EASEMENT

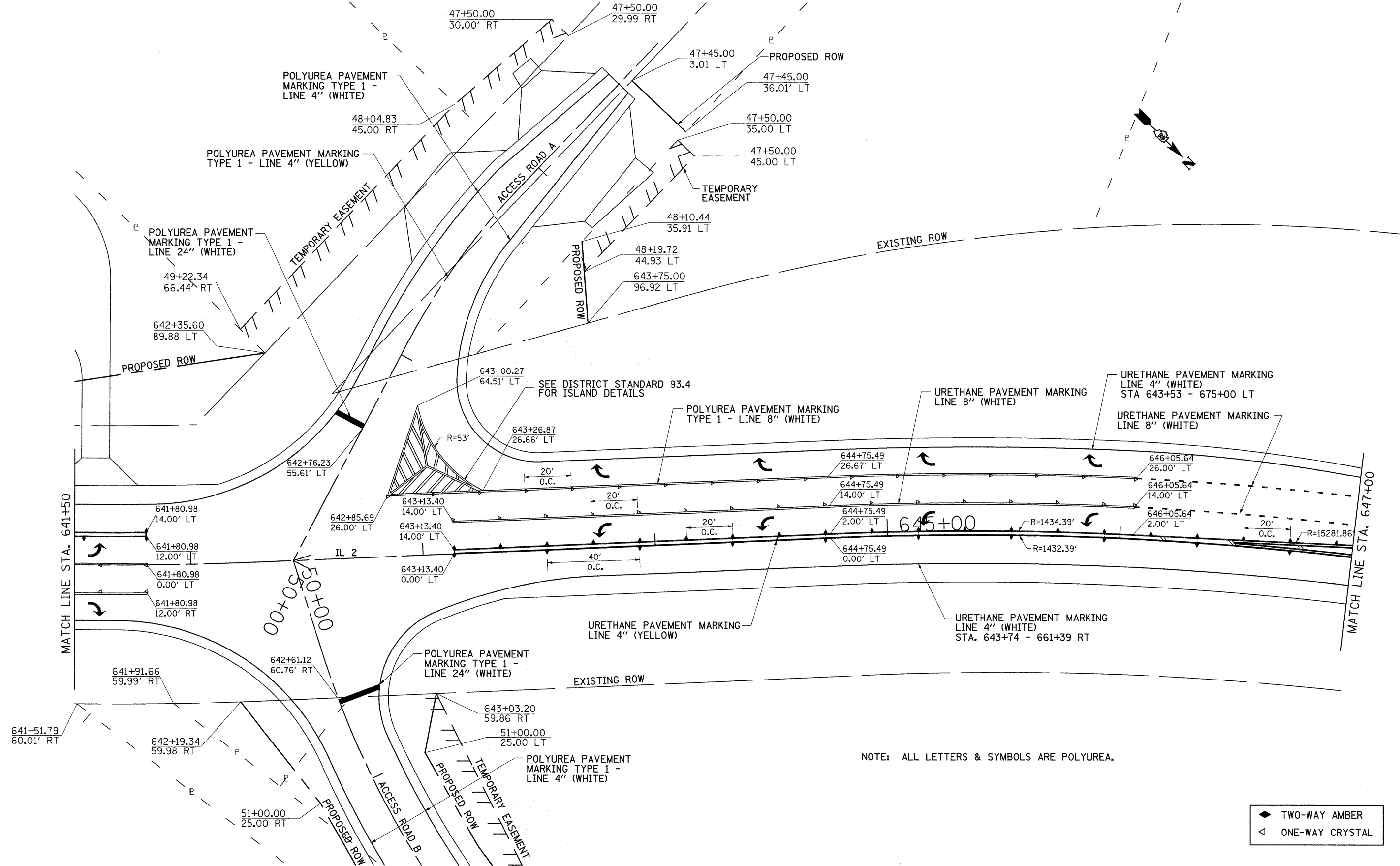

- ◆ TWO-WAY AMBER
- ◁ ONE-WAY CRYSTAL

FILE NAME =	USER NAME = cushmanbw	DESIGNED -	REVISED -	STATE OF ILLINOIS DEPARTMENT OF TRANSPORTATION	PAVEMENT MARKING, R.O.W. & EASEMENT	F.A.P. RTE.	SECTION	COUNTY	TOTAL SHEETS	SHEET NO.
ca\pw_work\FWIDOT\CUSHMANBW\dms34123\dms34123.dgn	6486pmk.dgn	DRAWN -	REVISED -			742	37R-3	OGLE	345	138
PLOT SCALE = 20.0000' / IN.	CHECKED -	REVISED -	REVISED -			CONTRACT NO. 84788				
PLOT DATE = Fri May 01 08:13:28 2009	DATE -	REVISED -	REVISED -			FED. ROAD DIST. NO.	ILLINOIS FED. AID PROJECT			
SCALE: SHEET NO. OF SHEETS STA. TO STA.										

PAVEMENT MARKING, R.O.W. & EASEMENT

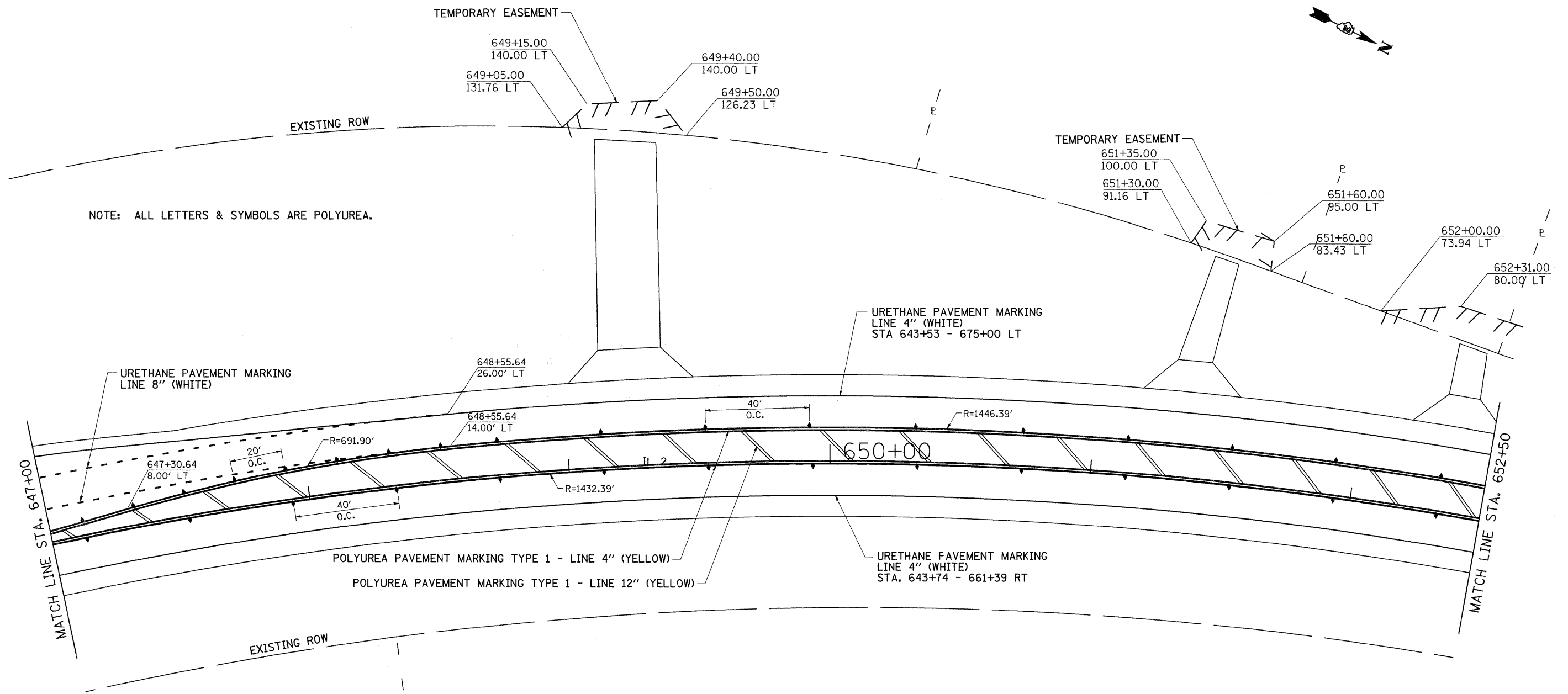

NOTE: ALL LETTERS & SYMBOLS ARE POLYUREA.

◆ TWO-WAY AMBER
◁ ONE-WAY CRYSTAL

FILE NAME =	USER NAME = cushmanbw	DESIGNED -	REVISED -	STATE OF ILLINOIS DEPARTMENT OF TRANSPORTATION	PAVEMENT MARKING, R.O.W. & EASEMENT	F.A.P. RTE.	SECTION	COUNTY	TOTAL SHEETS	SHEET NO.
c:\pw_work\PW\DOT\CUSHMANBW\dms34123\dms34123.dwg	6488pmk.dgn	DRAWN -	REVISED -			742	37R-3	OGLE	345	139
PLOT SCALE = 20.0000' / IN.	CHECKED -	REVISED -	REVISED -			CONTRACT NO. 84788				
PLOT DATE = Fri May 01 08:13:29 2009	DATE -	REVISED -	REVISED -			FED. ROAD DIST. NO.	ILLINOIS FED. AID PROJECT			

PAVEMENT MARKING, R.O.W. & EASEMENT

NOTE: ALL LETTERS & SYMBOLS ARE POLYUREA.

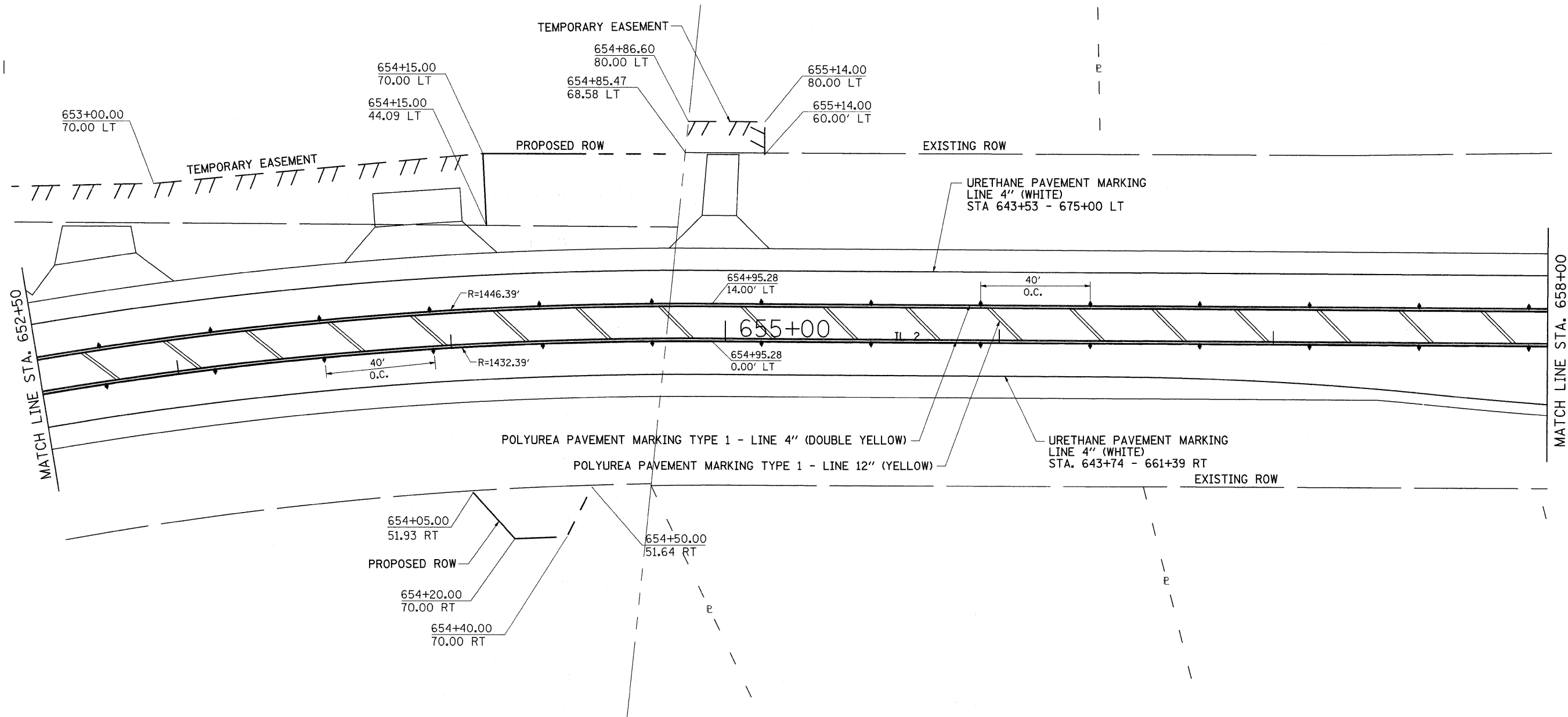
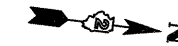

◆ TWO-WAY AMBER
◁ ONE-WAY CRYSTAL

FILE NAME =	USER NAME = cushmanbw	DESIGNED -	REVISED -	STATE OF ILLINOIS DEPARTMENT OF TRANSPORTATION	PAVEMENT MARKING, R.O.W. & EASEMENT	F.A.P. RTE.	SECTION	COUNTY	TOTAL SHEETS	SHEET NO.	
c:\pw_work\FWIDOT\CUSHMANBW\dms34123\dms34123.dwg	6486pmk.dgn	DRAWN -	REVISED -			742	37R-3	OGLE	345	140	
	PLOT SCALE = 20.0000' / IN.	CHECKED -	REVISED -			CONTRACT NO. 84788					
	PLOT DATE = Fri May 01 08:13:30 2009	DATE -	REVISED -			SCALE:	SHEET NO.	OF	SHEETS	STA.	TO STA.

PAVEMENT MARKING, R.O.W. & EASEMENT

NOTE: ALL LETTERS & SYMBOLS ARE POLYUREA.

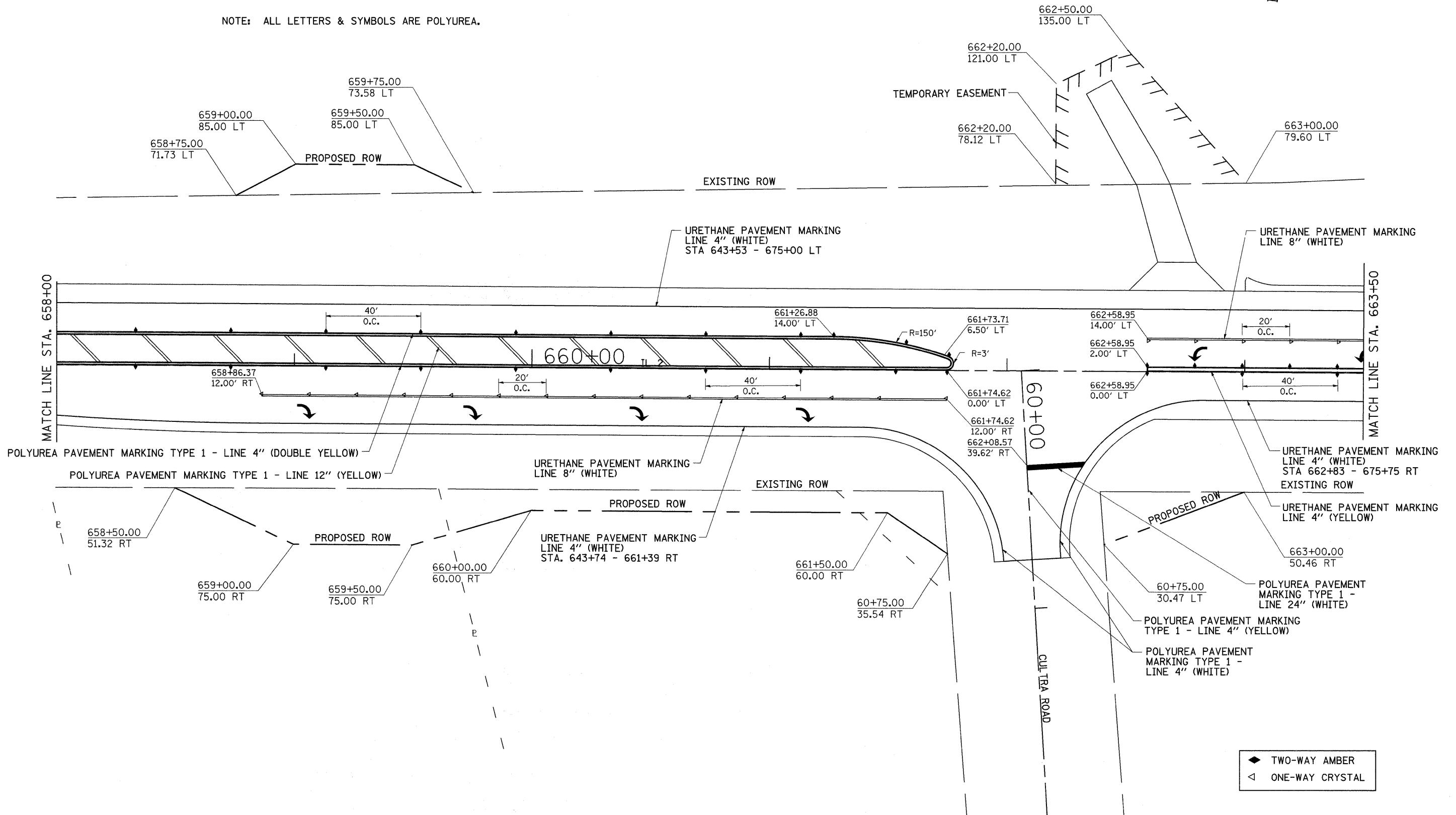

◆ TWO-WAY AMBER
◁ ONE-WAY CRYSTAL

FILE NAME =	USER NAME = cushmanbw	DESIGNED -	REVISED -	STATE OF ILLINOIS DEPARTMENT OF TRANSPORTATION	PAVEMENT MARKING, R.O.W. & EASEMENT	F.A.P. RTE.	SECTION	COUNTY	TOTAL SHEETS	SHEET NO.	
c:\pwork\pwork\DOT\CUSHMANBW\dms34123\dms34123.dgn	6486pmk.dgn	DRAWN -	REVISED -			742	37R-3	OGLE	345	141	
		CHECKED -	REVISED -			CONTRACT NO. 84788					
		DATE -	REVISED -			FED. ROAD DIST. NO. ILLINOIS FED. AID PROJECT					
					SCALE:	SHEET NO.	OF	SHEETS	STA.	TO STA.	

PAVEMENT MARKING, R.O.W. & EASEMENT

NOTE: ALL LETTERS & SYMBOLS ARE POLYUREA.

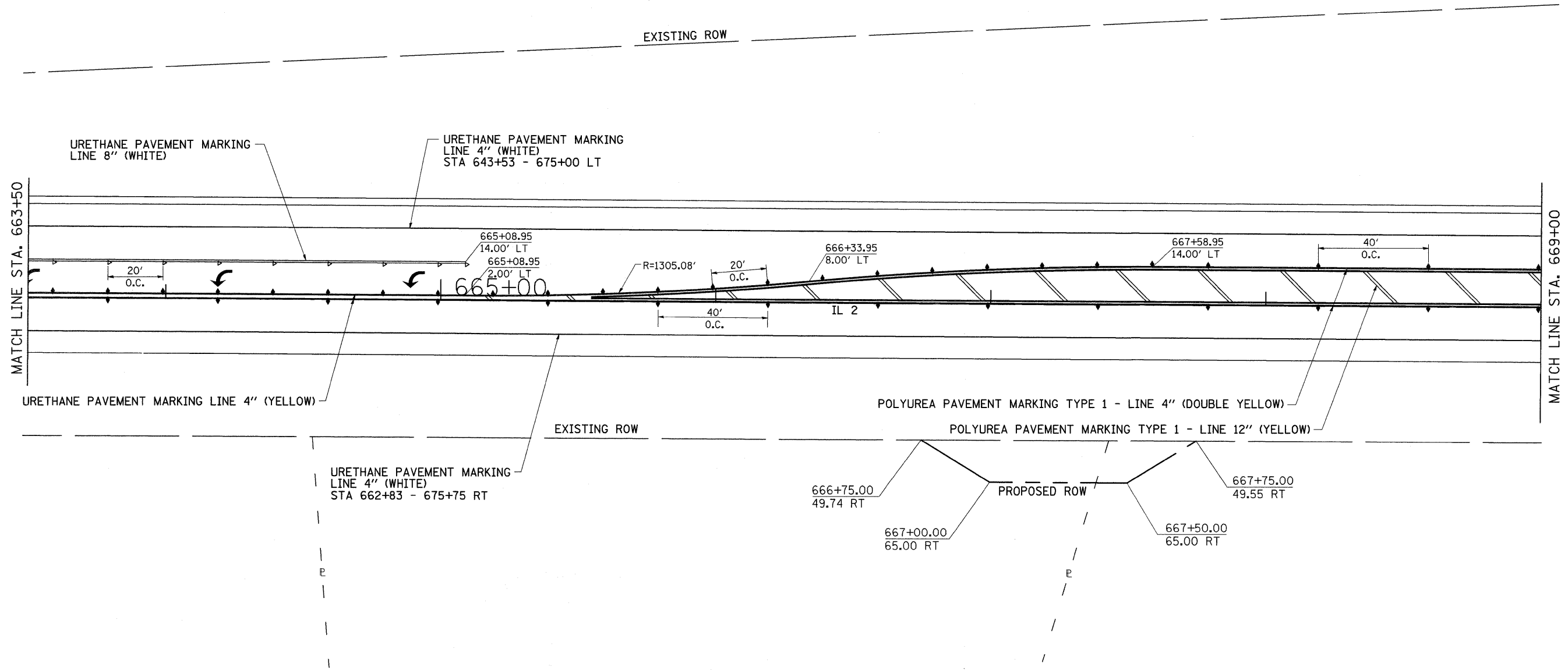

◆ TWO-WAY AMBER
◁ ONE-WAY CRYSTAL

FILE NAME =	USER NAME = cushmanbw	DESIGNED -	REVISED -
c:\pwork\FWIDOT\CUSHMANBW\dms34123\dms34123.dwg		DRAWN -	REVISED -
		CHECKED -	REVISED -
		DATE -	REVISED -

STATE OF ILLINOIS
DEPARTMENT OF TRANSPORTATION

PAVEMENT MARKING, R.O.W. & EASEMENT

SCALE: SHEET NO. OF SHEETS STA. TO STA.

F.A.P. RTE.	SECTION	COUNTY	TOTAL SHEETS	SHEET NO.
742	37R-3	OGLE	345	142
CONTRACT NO. 84788				
FED. ROAD DIST. NO. ILLINOIS FED. AID PROJECT				

PAVEMENT MARKING, R.O.W. & EASEMENT

NOTE: ALL LETTERS & SYMBOLS ARE POLYUREA.

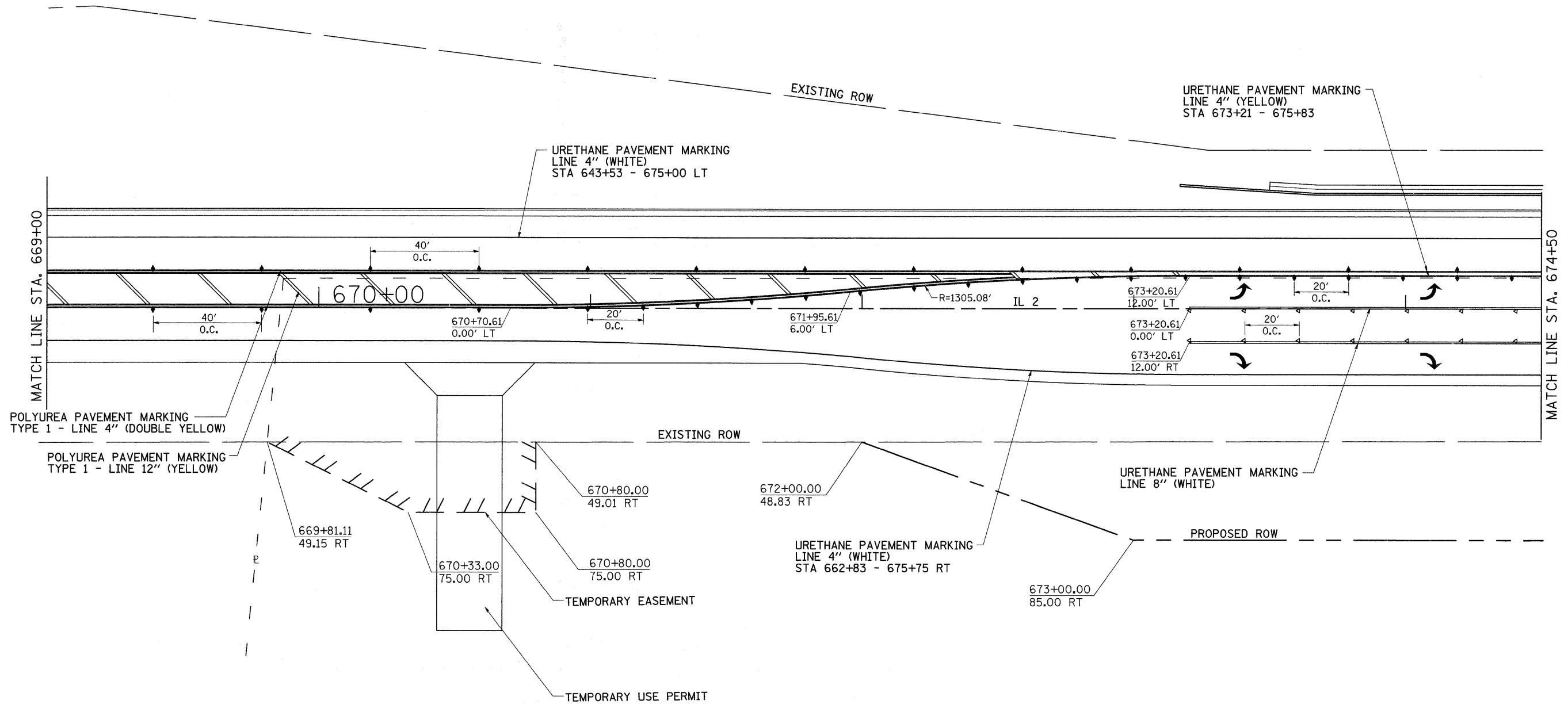

◆ TWO-WAY AMBER
◁ ONE-WAY CRYSTAL

FILE NAME = c:\pwork\PWIDOT\CUSHMANBW\dms34123\d6486pmk.dgn	USER NAME = cushmanbw	DESIGNED -	REVISED -	STATE OF ILLINOIS DEPARTMENT OF TRANSPORTATION	PAVEMENT MARKING, R.O.W. & EASEMENT	F.A.P. RTE. 742	SECTION 37R-3	COUNTY OGLE	TOTAL SHEETS 345	SHEET NO. 143		
	PLOT SCALE = 20.0000' / IN.	CHECKED -	REVISED -			SCALE:	SHEET NO. OF SHEETS	STA. TO STA.	CONTRACT NO. 84788			
	PLOT DATE = Fri May 01 08:13:32 2009	DATE -	REVISED -			FED. ROAD DIST. NO.	ILLINOIS FED. AID PROJECT					

PAVEMENT MARKING, R.O.W. & EASEMENT

NOTE: ALL LETTERS & SYMBOLS ARE POLYUREA.

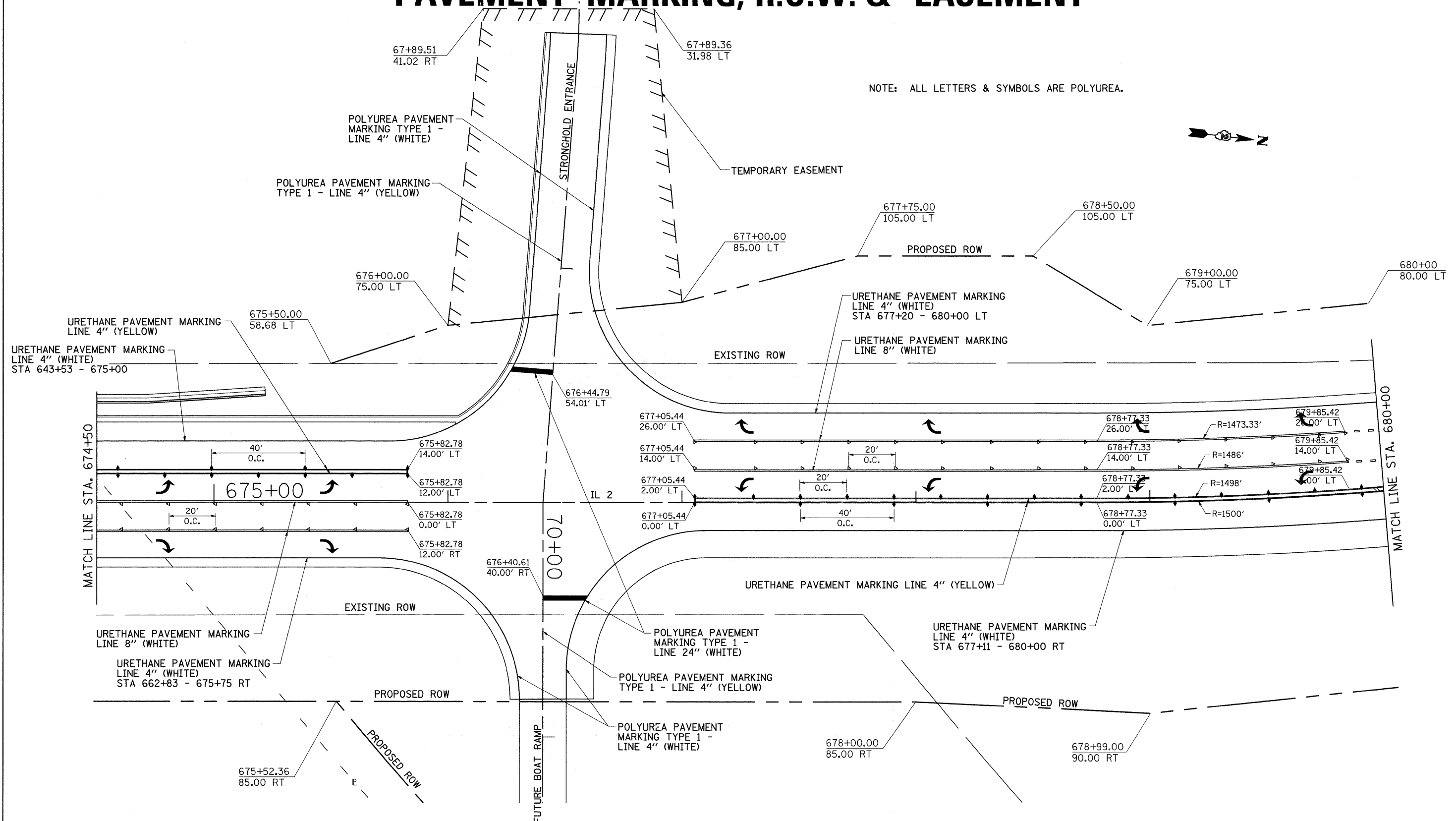

◆	TWO-WAY AMBER
◁	ONE-WAY CRYSTAL

FILE NAME =	USER NAME = cushmanbw	DESIGNED -	REVISED -	STATE OF ILLINOIS DEPARTMENT OF TRANSPORTATION	PAVEMENT MARKING, R.O.W. & EASEMENT	F.A.P. RTE.	SECTION	COUNTY	TOTAL SHEETS	SHEET NO.	
c:\pw_work\PW1DOT\CUSHMANBW\dms34123\dms34123.dwg	6486pmk.dgn	DRAWN -	REVISED -			742	37R-3	OGLE	345	144	
PLOT SCALE = 20.0000' / IN.	CHECKED -	REVISED -	REVISED -			CONTRACT NO. 84788					
PLOT DATE = Fri May 01 08:13:32 2009	DATE -	REVISED -	REVISED -			SCALE:	SHEET NO.	OF	SHEETS	STA.	TO STA.

PAVEMENT MARKING, R.O.W. & EASEMENT

NOTE: ALL LETTERS & SYMBOLS ARE POLYUREA.

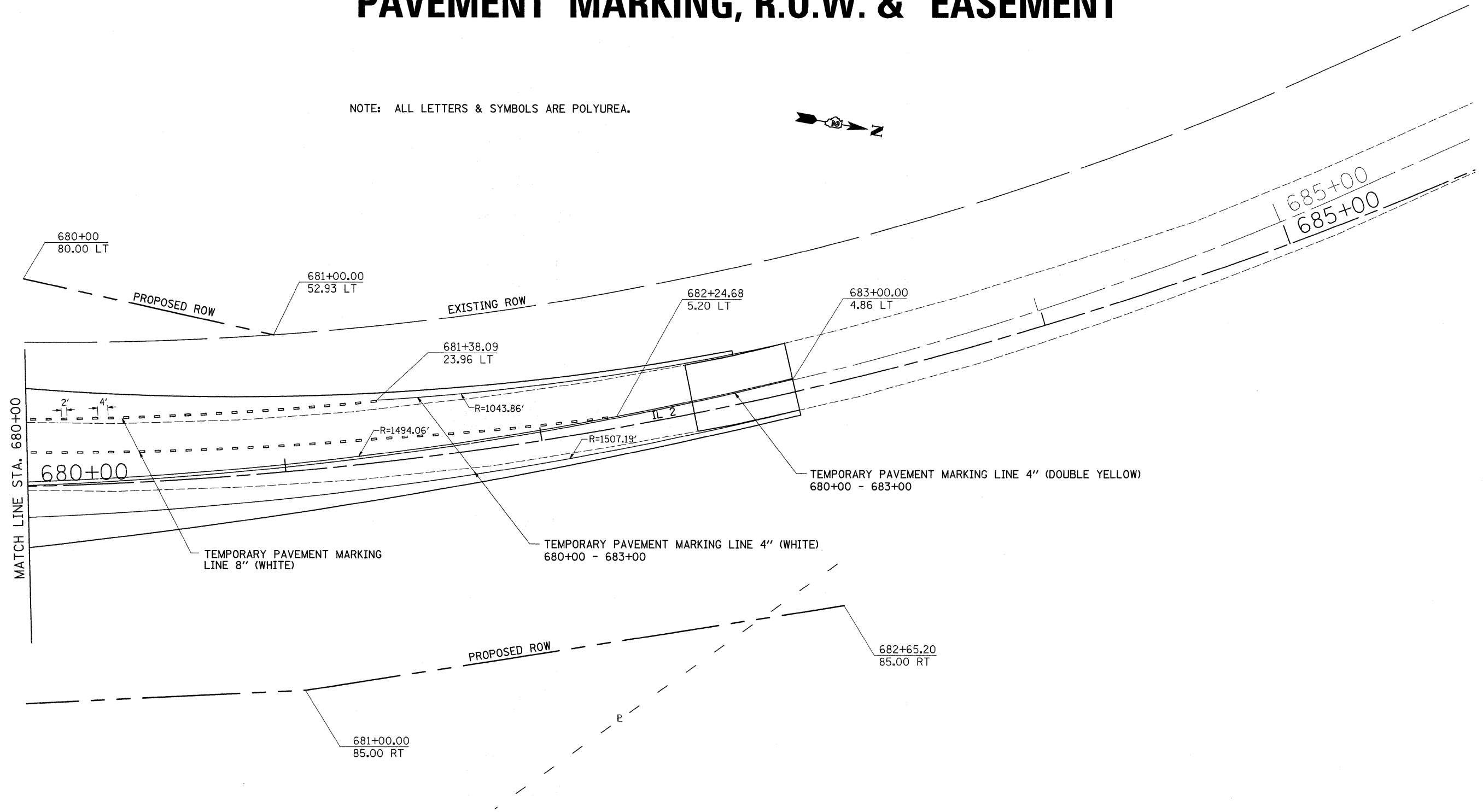

◆ TWO-WAY AMBER
◁ ONE-WAY CRYSTAL

FILE NAME =	USER NAME = cushmanbw	DESIGNED -	REVISED -	STATE OF ILLINOIS DEPARTMENT OF TRANSPORTATION	PAVEMENT MARKING, R.O.W. & EASEMENT	F.A.P. RTE.	SECTION	COUNTY	TOTAL SHEETS	SHEET NO.
c:\pw_work\PW\DOT\CUSHMANBW\dms34123\dms34123.dwg	6486pmk.dgn	DRAWN -	REVISED -			742	37R-3	OGLE	345	145
PLOT SCALE = 20.0000' / IN.	CHECKED -	REVISED -	REVISED -			CONTRACT NO. 84788				
PLOT DATE = Fri May 01 08:13:33 2009	DATE -	REVISED -	REVISED -			FED. ROAD DIST. NO.	ILLINOIS FED. AID PROJECT			
SCALE:		SHEET NO. OF SHEETS		STA. TO STA.						

PAVEMENT MARKING, R.O.W. & EASEMENT

NOTE: ALL LETTERS & SYMBOLS ARE POLYUREA.

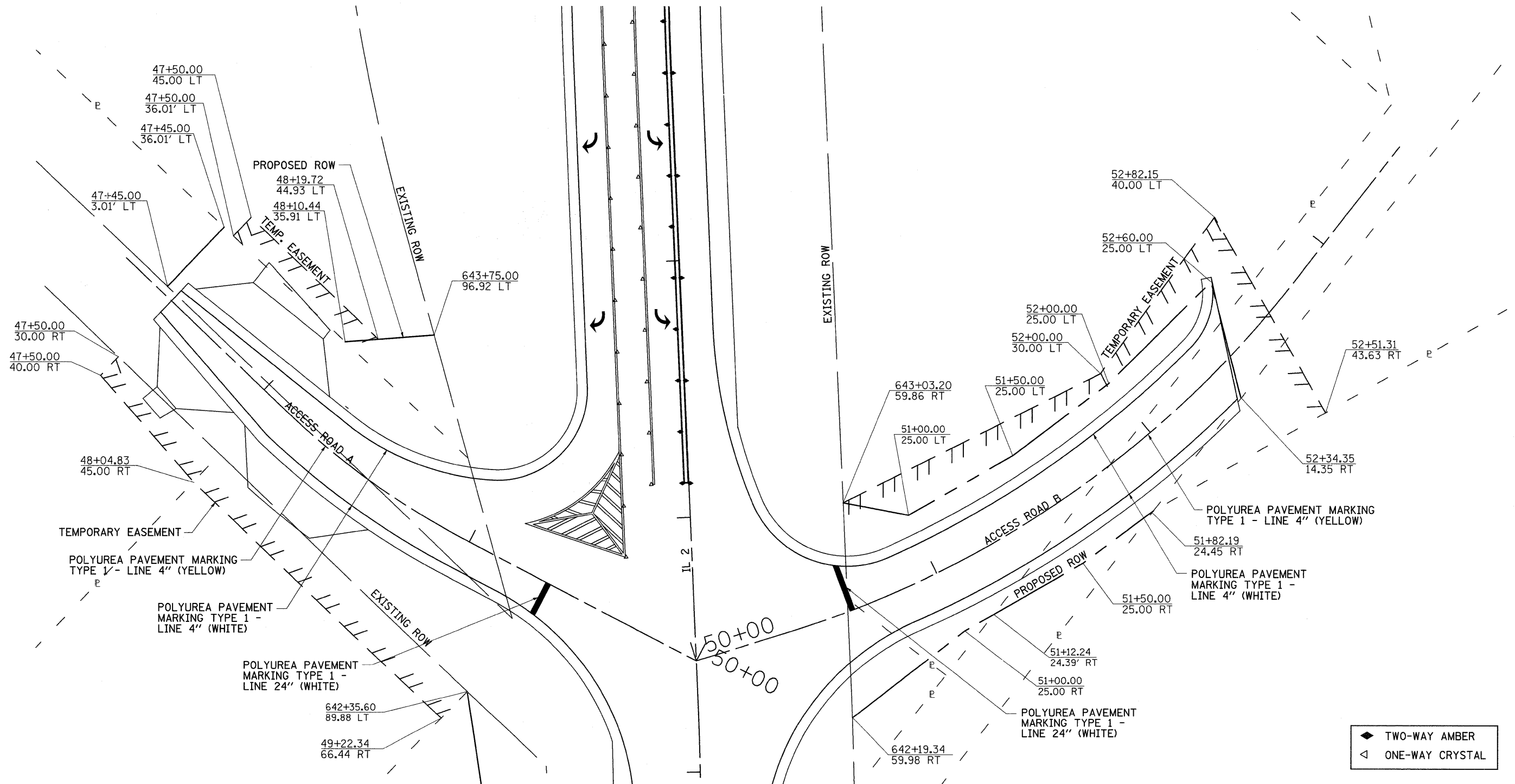

◆ TWO-WAY AMBER
◁ ONE-WAY CRYSTAL

FILE NAME =	USER NAME = cushmanbw	DESIGNED -	REVISED -	STATE OF ILLINOIS DEPARTMENT OF TRANSPORTATION	PAVEMENT MARKING, R.O.W. & EASEMENT	F.A.P. RTE.	SECTION	COUNTY	TOTAL SHEETS	SHEET NO.
ca\pw_work\FWIDOT\CUSHMANBW\dms34123\d6486pmk.dgn	DRAWN -	REVISED -	742			37R-3	OGLE	345	146	
PLOT SCALE = 20.0000 / IN.	CHECKED -	REVISED -	CONTRACT NO. 84788							
PLOT DATE = Fri May 01 08:13:35 2009	DATE -	REVISED -	ILLINOIS FED. AID PROJECT							
				SCALE:	SHEET NO. OF SHEETS	STA.	TO STA.			

PAVEMENT MARKING, R.O.W. & EASEMENT

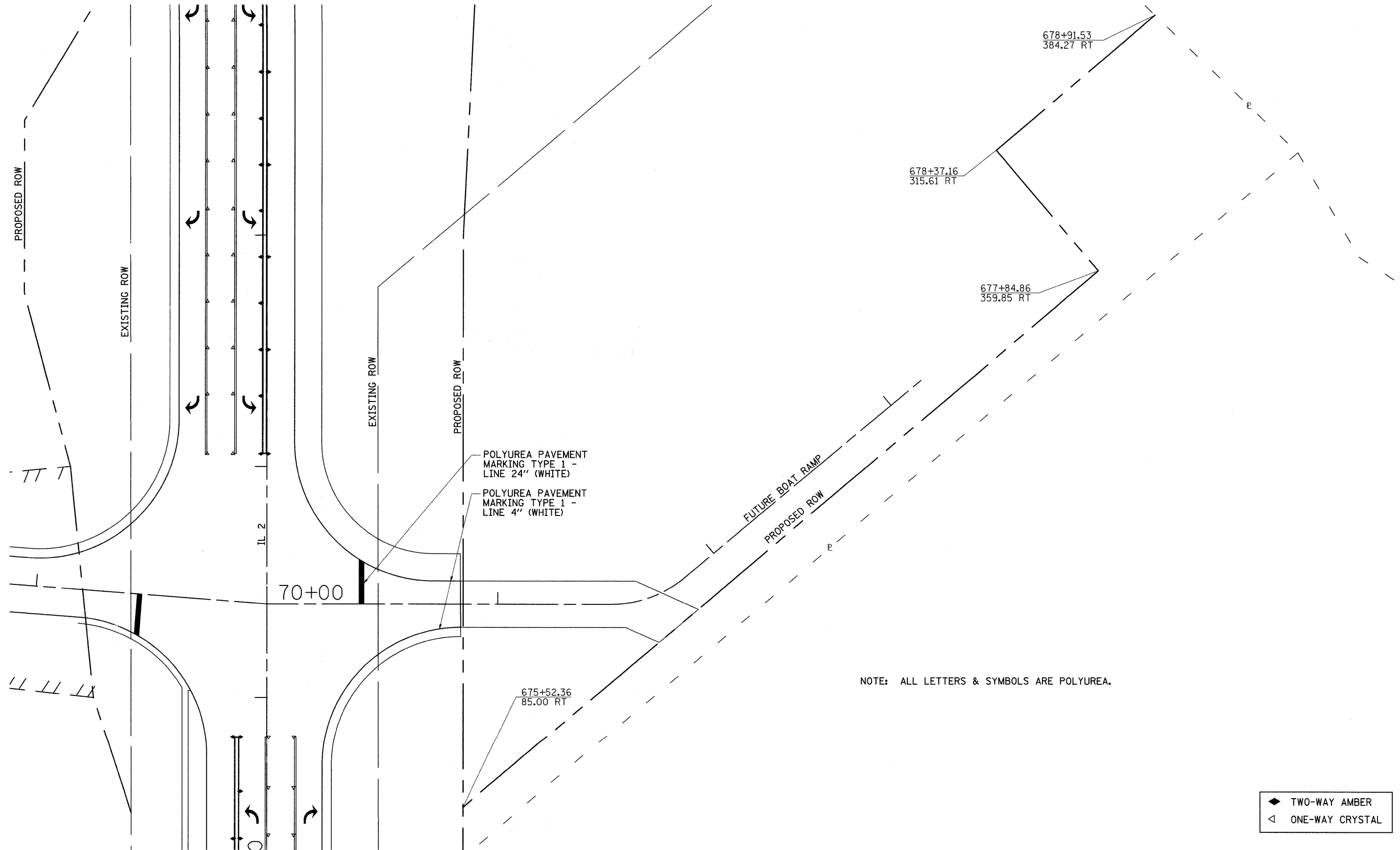

◀ TWO-WAY AMBER
◁ ONE-WAY CRYSTAL

FILE NAME =	USER NAME = cushmanbw	DESIGNED -	REVISED -	STATE OF ILLINOIS DEPARTMENT OF TRANSPORTATION	PAVEMENT MARKING, R.O.W. & EASEMENT	F.A.P. RTE.	SECTION	COUNTY	TOTAL SHEETS	SHEET NO.
at\pw_work\FWIDOT\CUSHMANBW\dms34123\dms34123.dgn	6486pmk.dgn	DRAWN -	REVISED -			742	37R-3	OGLE	345	147
PLOT SCALE = 20.0000' / IN.	CHECKED -	REVISED -	REVISED -			CONTRACT NO. 84788				
PLOT DATE = Fri May 01 08:13:35 2009	DATE -	REVISED -	REVISED -			FED. ROAD DIST. NO.	ILLINOIS FED. AID PROJECT			
SCALE: SHEET NO. OF SHEETS STA. TO STA.										

PAVEMENT ELEVATIONS

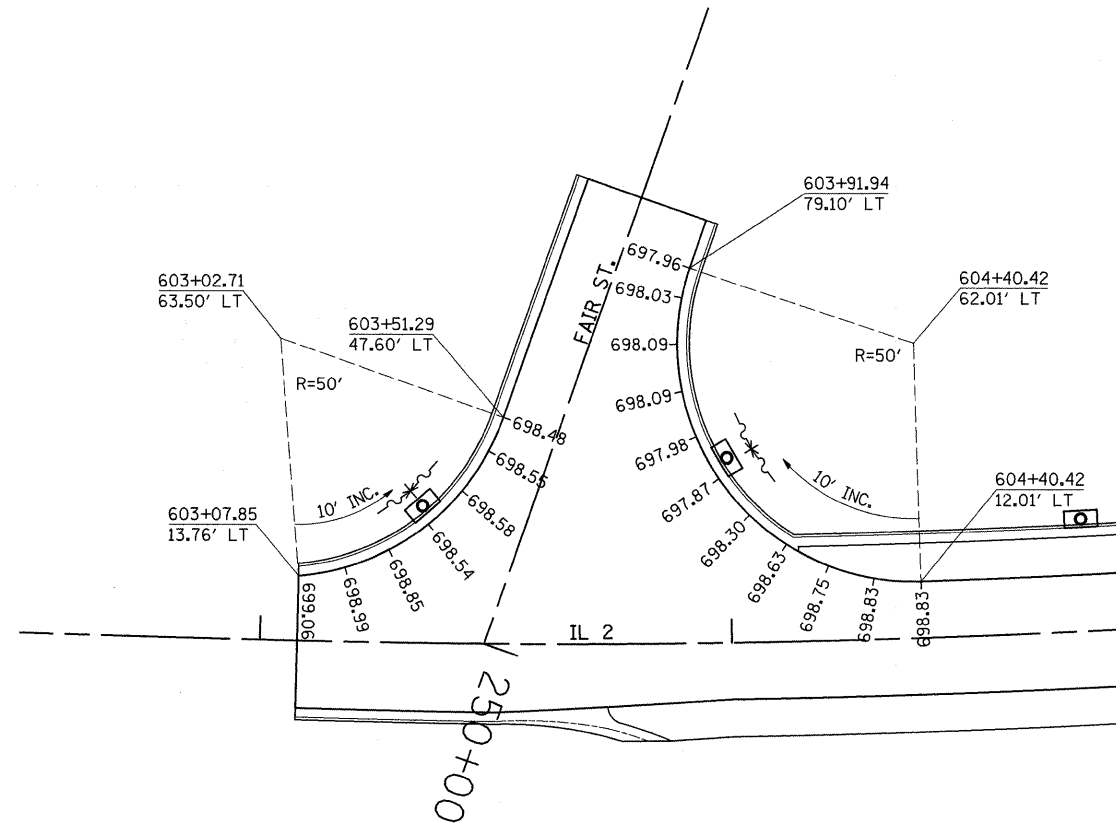

FILE NAME =	USER NAME = cushmanbw	DESIGNED -	REVISED -	STATE OF ILLINOIS DEPARTMENT OF TRANSPORTATION	PAVEMENT ELEVATIONS	F.A.P. RTE.	SECTION	COUNTY	TOTAL SHEETS	SHEET NO.	
c:\pw\work\FWIDOT\CUSHMANBW\dms34123\dms34123.dwg	6486eLdgn	DRAWN -	REVISED -			742	37R-3	OGLE	345	148	
	PLOT SCALE = 20.0000' / IN.	CHECKED -	REVISED -			CONTRACT NO. 84788					
	PLOT DATE = Fri May 01 08:18:23 2009	DATE -	REVISED -			SCALE:	SHEET NO. OF SHEETS	STA. TO STA.	FED. ROAD DIST. NO.	ILLINOIS FED. AID PROJECT	

PAVEMENT ELEVATIONS

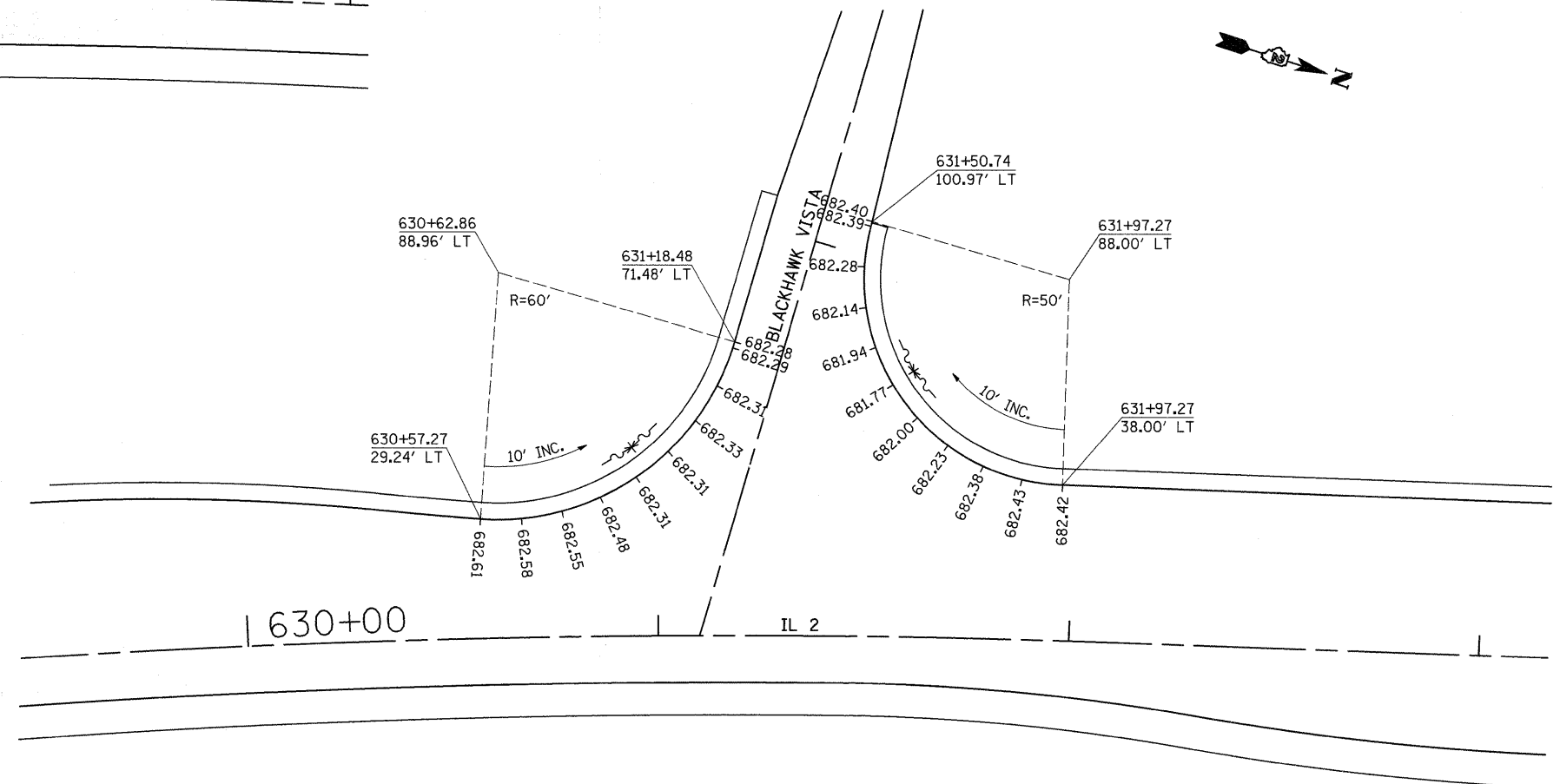
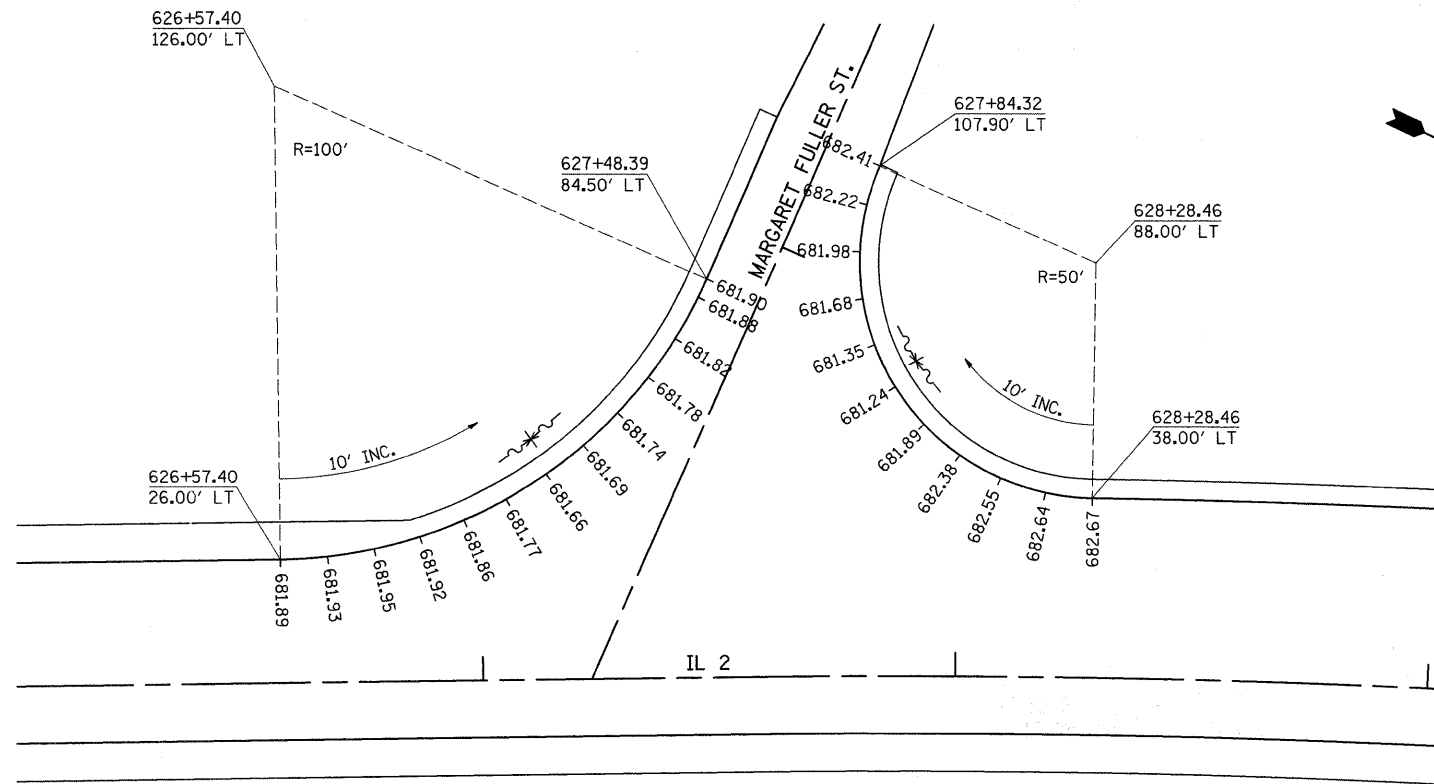

FILE NAME =	USER NAME = cushmanbw	DESIGNED -	REVISED -	STATE OF ILLINOIS DEPARTMENT OF TRANSPORTATION	PAVEMENT ELEVATIONS	F.A.P. RTE.	SECTION	COUNTY	TOTAL SHEETS	SHEET NO.	
c:\pw_work\PWIDOT\CUSHMANBW\dms34123\dms34123.dgn	6486e1.dgn	DRAWN -	REVISED -			742	37R-3	OGLE	345	149	
		CHECKED -	REVISED -			CONTRACT NO. 84788					
		DATE -	REVISED -			ILLINOIS FED. AID PROJECT					
					SCALE:	SHEET NO.	OF	SHEETS	STA.	TO STA.	

PAVEMENT ELEVATIONS

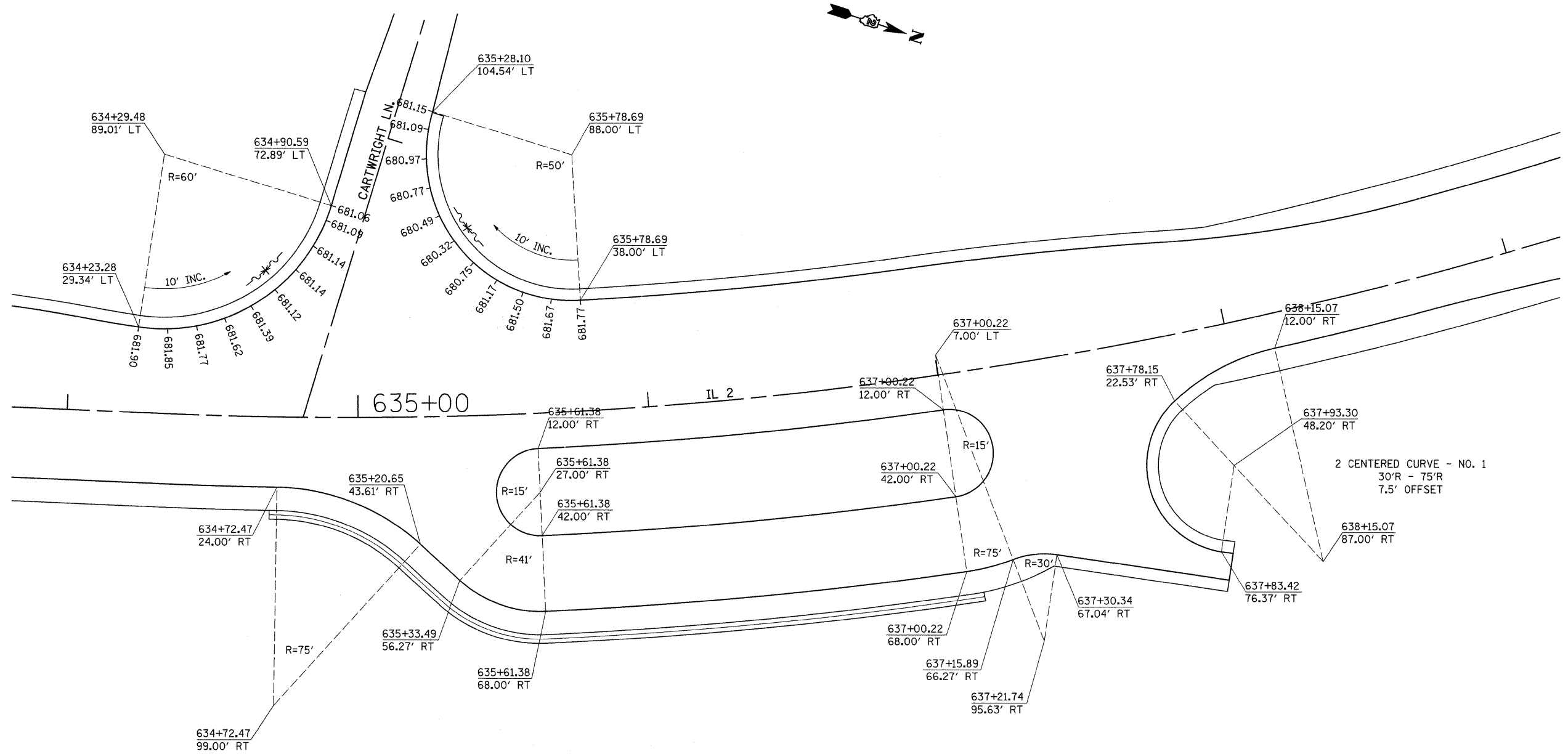

FILE NAME =	USER NAME = cushmanbw	DESIGNED -	REVISED -	STATE OF ILLINOIS DEPARTMENT OF TRANSPORTATION	PAVEMENT ELEVATIONS	F.A.P. RTE:	SECTION	COUNTY	TOTAL SHEETS	SHEET NO.
c:\pwork\pwork\DOT\CUSHMANBW\dms34123\dms34123.dgn	DRAWN -	REVISED -	742			37R-3	OGLE	345	150	
PLOT SCALE = 20.0000' / IN.	CHECKED -	REVISED -	CONTRACT NO. 84788							
PLOT DATE = Fri May 01 08:18:24 2009	DATE -	REVISED -	FED. ROAD DIST. NO. ILLINOIS FED. AID PROJECT							
SCALE: SHEET NO. OF SHEETS STA. TO STA.										

PAVEMENT ELEVATIONS

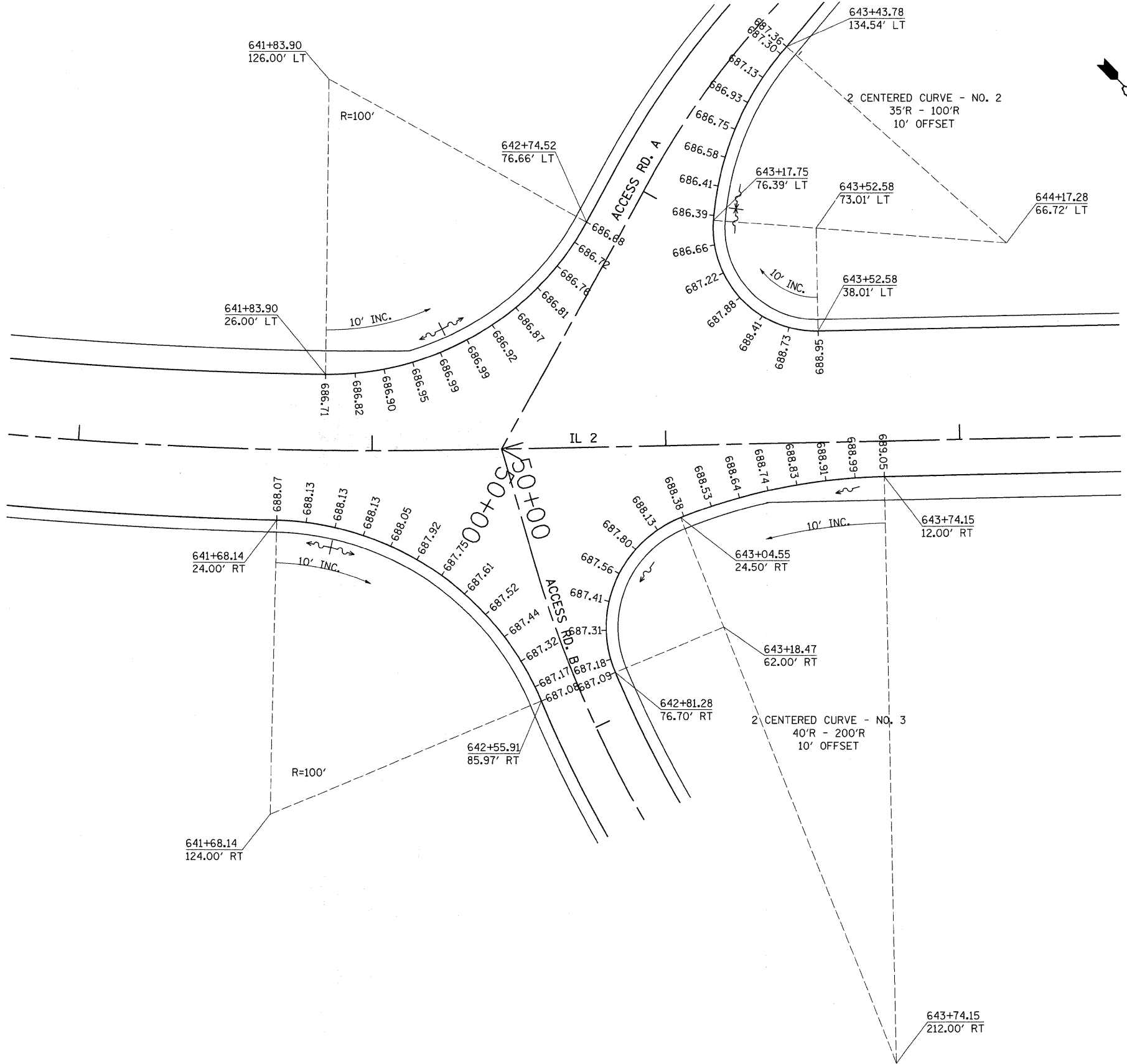

FILE NAME = c:\pw_work\FWIDOT\CUSHMANBW\dms34123.dwg	USER NAME = cushmanbw 6486e1.dgn	DESIGNED -	REVISED -	STATE OF ILLINOIS DEPARTMENT OF TRANSPORTATION	PAVEMENT ELEVATIONS	F.A.P. RTE. 742	SECTION 37R-3	COUNTY OGLE	TOTAL SHEETS 345	SHEET NO. 151
PLOT SCALE = 20.0000' / IN.		CHECKED -	REVISED -	SCALE: SHEET NO. OF SHEETS STA. TO STA.			CONTRACT NO. 84788			
PLOT DATE = Fri May 01 08:18:24 2009		DATE -	REVISED -	FED. ROAD DIST. NO. ILLINOIS FED. AID PROJECT						

PAVEMENT ELEVATIONS

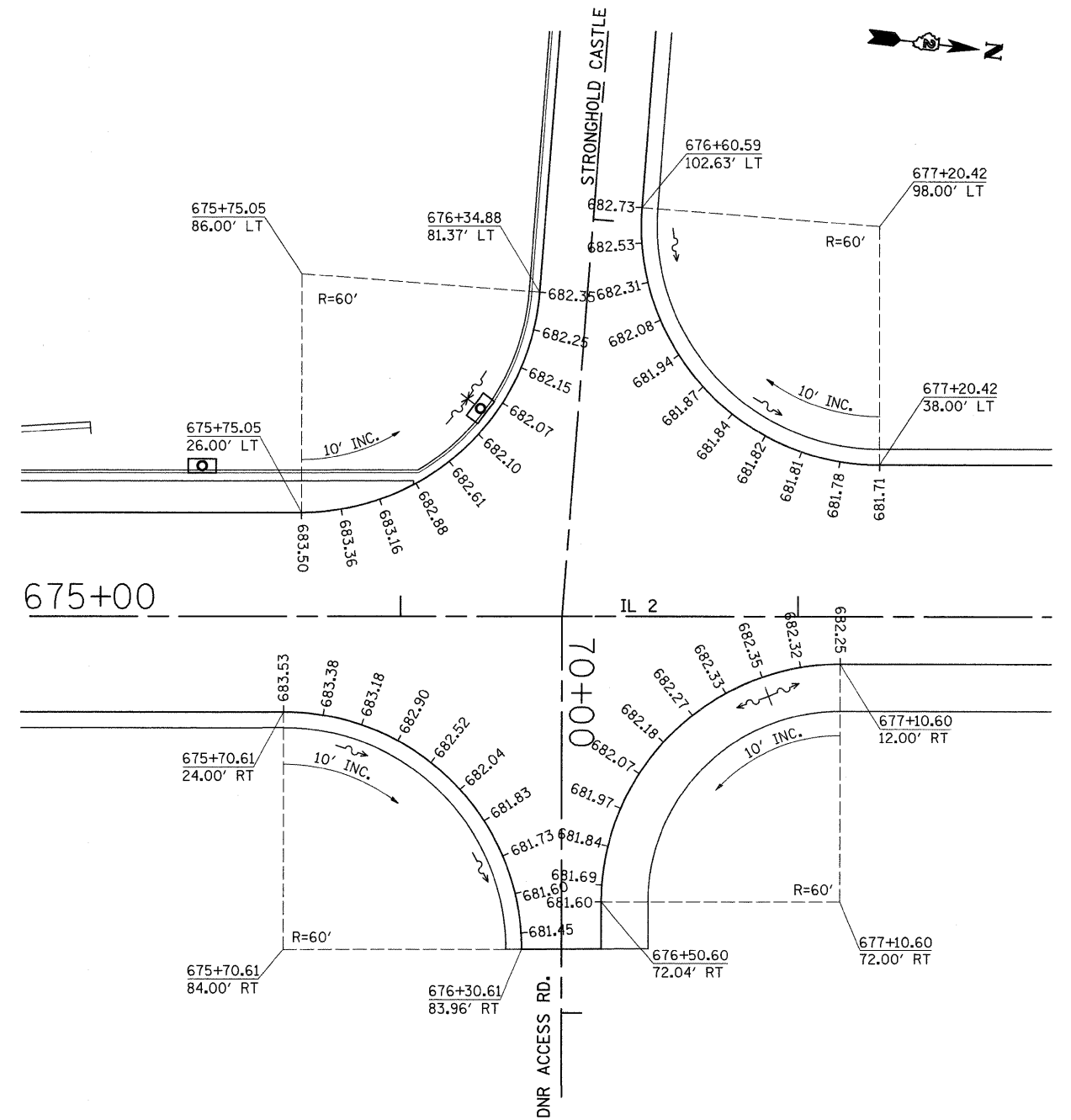
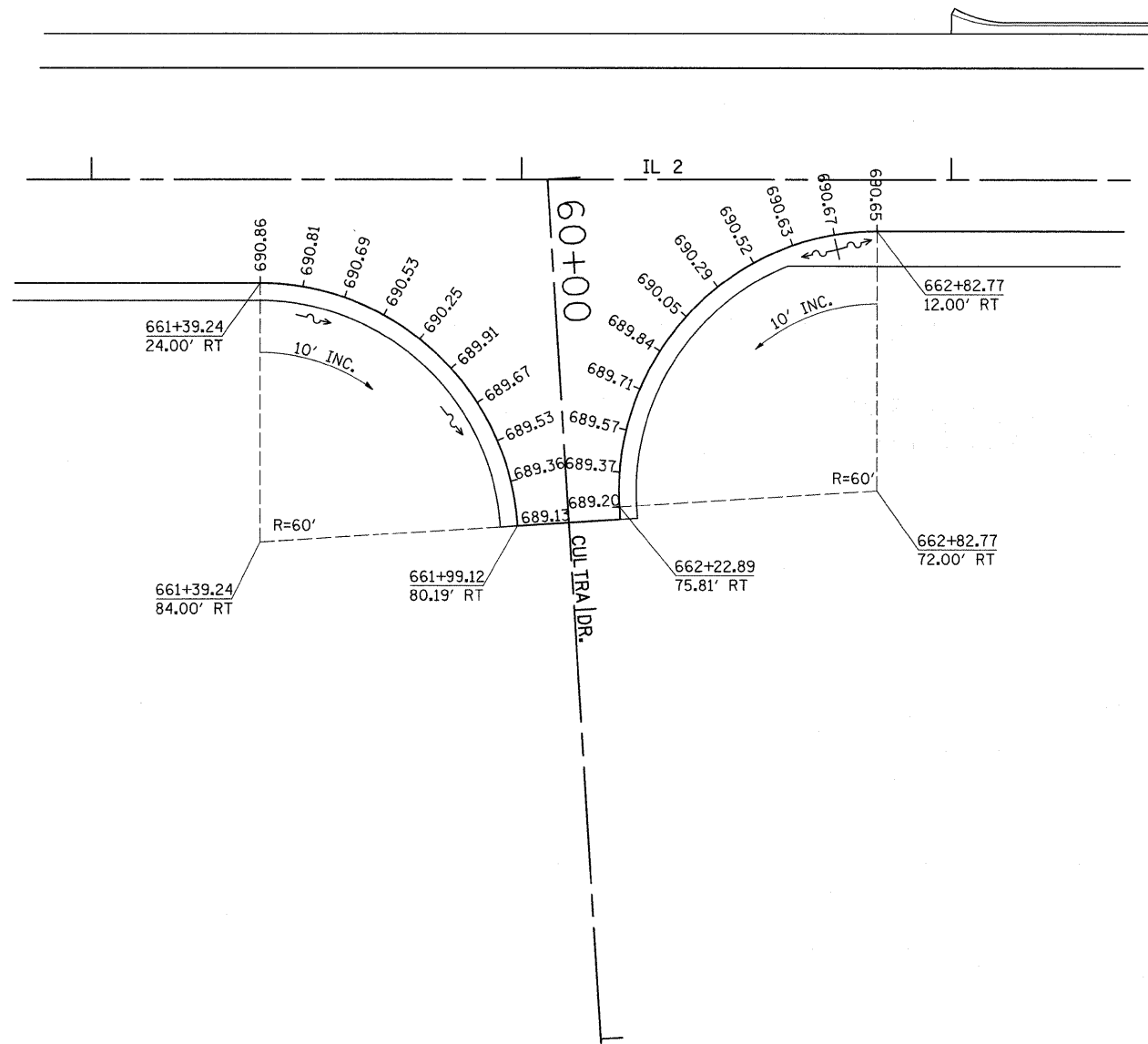

FILE NAME =	USER NAME = cushmanbw	DESIGNED -	REVISED -
c:\pwork\PWIDOT\CUSHMANBW\dms34123\dms34123.dwg	6486e1.dgn	DRAWN -	REVISED -
	PLOT SCALE = 20.0000' / IN.	CHECKED -	REVISED -
	PLOT DATE = Fri May 01 08:18:04 2009	DATE -	REVISED -

STATE OF ILLINOIS
DEPARTMENT OF TRANSPORTATION

PAVEMENT ELEVATIONS

SCALE: SHEET NO. OF SHEETS STA. TO STA.

F.A.P. RTE.	SECTION	COUNTY	TOTAL SHEETS	SHEET NO.
742	37R-3	OGLE	345	152
CONTRACT NO. 84788				
FED. ROAD DIST. NO. ILLINOIS FED. AID PROJECT				

PAVEMENT JOINTS

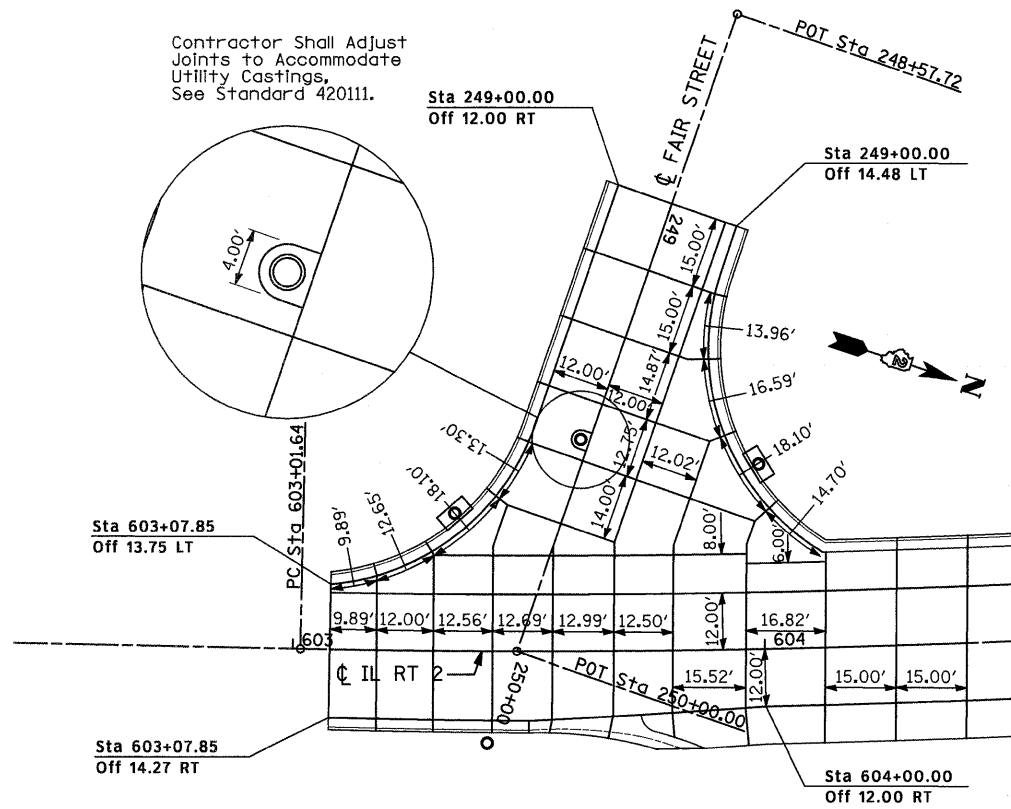

NOTE:
DIMENSIONS SHOWN ON CURVES ARE ALONG CENTERLINE, EDGE OF PAVEMENT DIMENSIONS BETWEEN JOINTS WILL VARY.

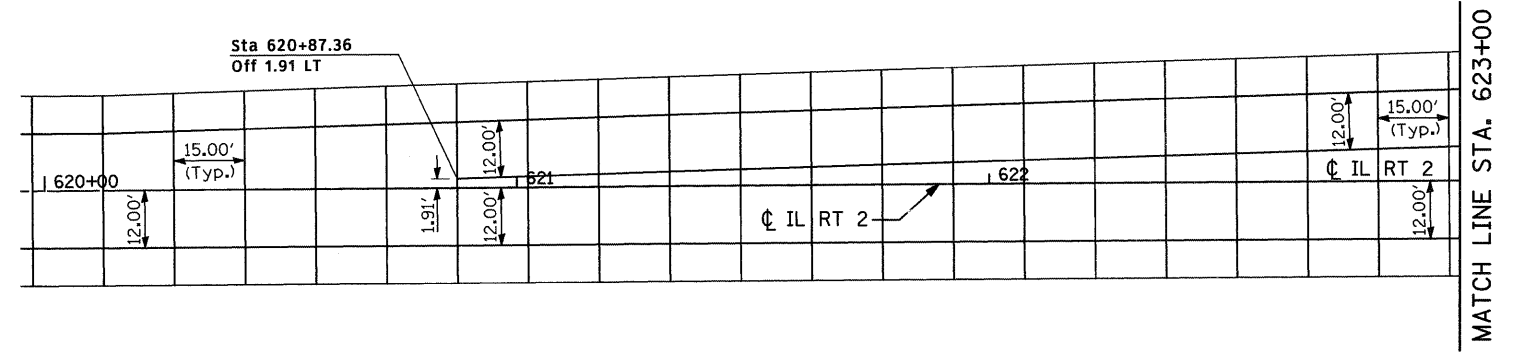

NOTE:
DIMENSIONS SHOWN ON CURVES ARE ALONG CENTERLINE, EDGE OF PAVEMENT DIMENSIONS BETWEEN JOINTS WILL VARY.

FILE NAME = c:\pwork\FWIDOT\CUSHMANB\dm34123\pvt\Joints.dgn	USER NAME = cushmanbw	DESIGNED - DRAWN -	REVISED - REVISED -
PLOT SCALE = 20.0000' / IN.	CHECKED -	REVISED -	REVISED -
PLOT DATE = Fri May 01 08:22:30 2009	DATE -	REVISED -	REVISED -

STATE OF ILLINOIS
DEPARTMENT OF TRANSPORTATION

PAVEMENT JOINTS

SCALE: SHEET NO. OF SHEETS STA. TO STA.

F.A.P. RTE. 742	SECTION 37R-3	COUNTY OGLE	TOTAL SHEETS 345	SHEET NO. 153
CONTRACT NO. 84788				
FED. ROAD DIST. NO. ILLINOIS FED. AID PROJECT				

PAVEMENT JOINTS

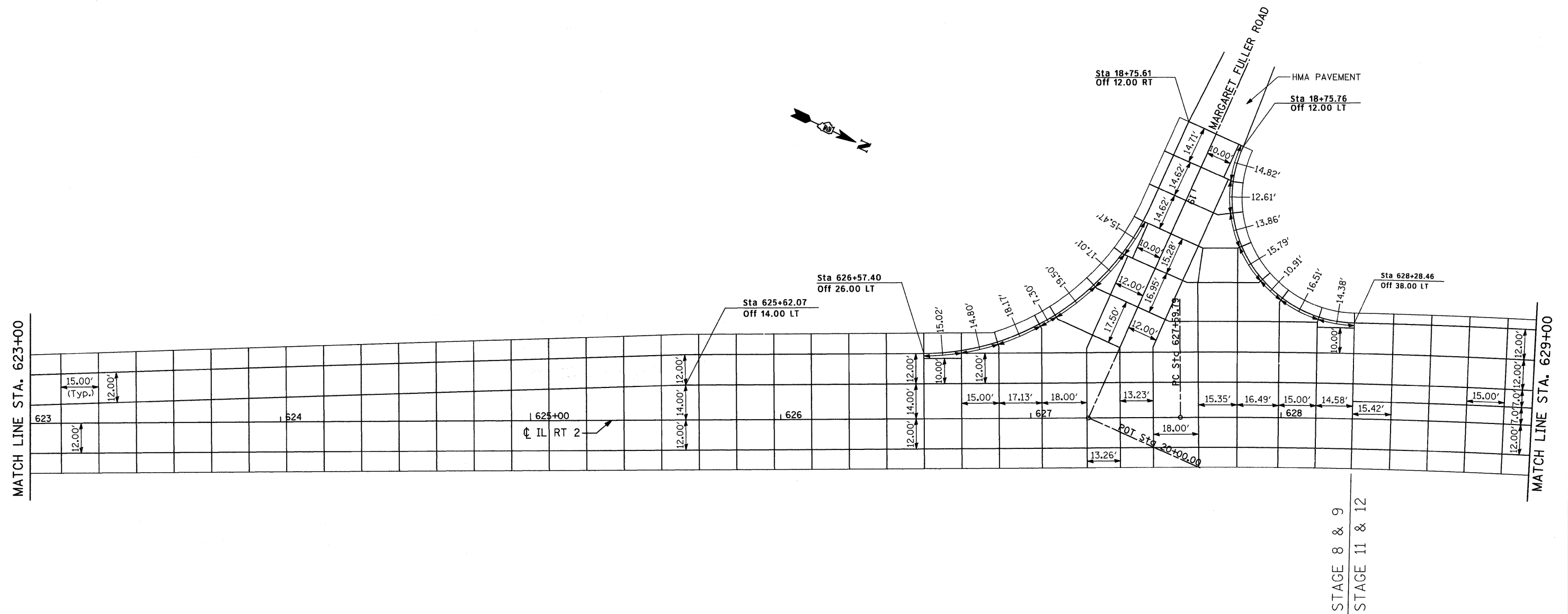

NOTE:
DIMENSIONS SHOWN ON CURVES
ARE ALONG CENTERLINE, EDGE
OF PAVEMENT DIMENSIONS
BETWEEN JOINTS WILL VARY.

FILE NAME =	USER NAME = cushmanbw	DESIGNED -	REVISED -	STATE OF ILLINOIS DEPARTMENT OF TRANSPORTATION	PAVEMENT JOINTS				F.A.P. RTE.	SECTION	COUNTY	TOTAL SHEETS	SHEET NO.
ct:\pw_work\PWIDOT\CUSHMANBW\dms34123\pvt_Joints.dgn		DRAWN -	REVISED -		742	37R-3	OGLE	345	154				
PLOT SCALE = 20.0000' / IN.		CHECKED -	REVISED -		SCALE: SHEET NO. OF SHEETS STA. TO STA.				CONTRACT NO. 84788				
PLOT DATE = Fri May 01 08:22:31 2009		DATE -	REVISED -						ILLINOIS FED. AID PROJECT				

PAVEMENT JOINTS

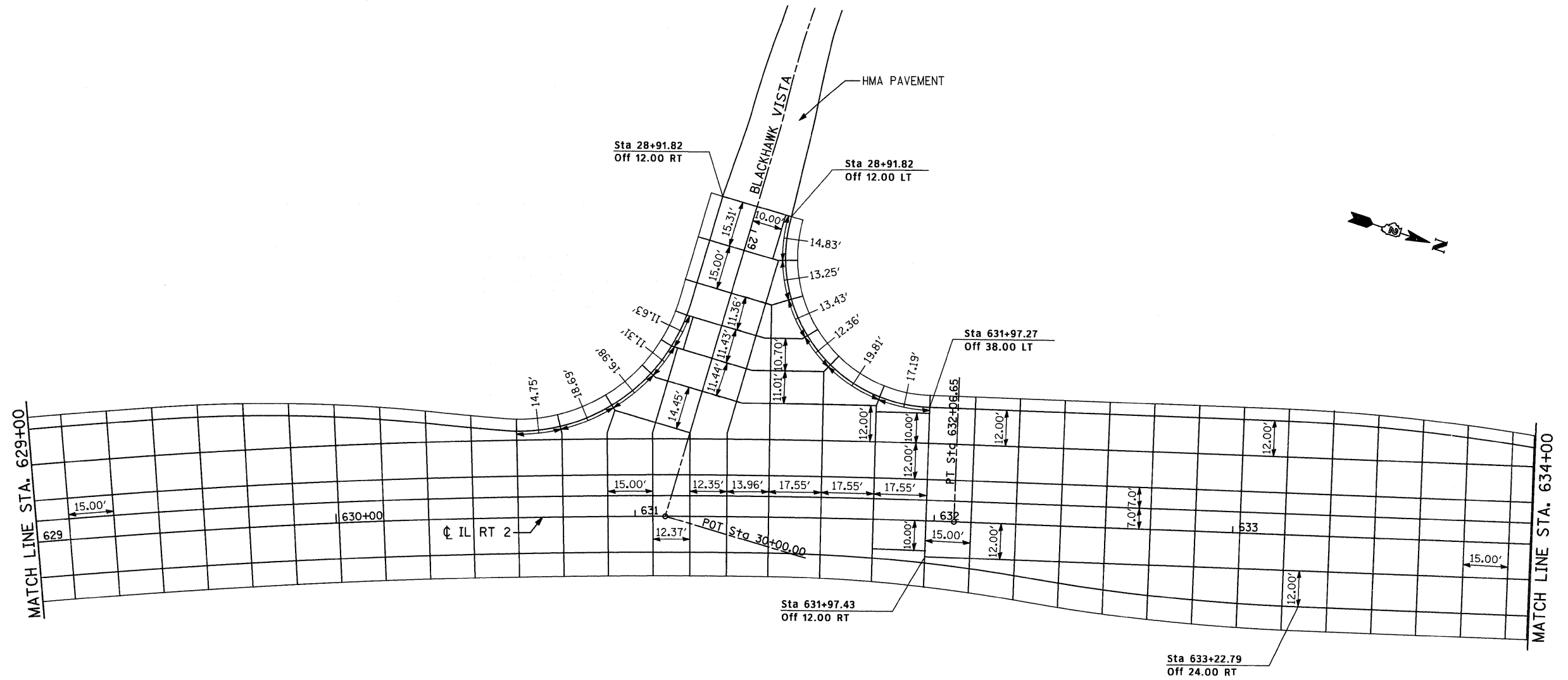

NOTE:
DIMENSIONS SHOWN ON CURVES
ARE ALONG CENTERLINE, EDGE
OF PAVEMENT DIMENSIONS
BETWEEN JOINTS WILL VARY.

FILE NAME =	USER NAME = cushmanbw	DESIGNED -	REVISED -	STATE OF ILLINOIS DEPARTMENT OF TRANSPORTATION	PAVEMENT JOINTS				F.A.P. RTE.	SECTION	COUNTY	TOTAL SHEETS	SHEET NO.		
c:\pw\work\PWIDOT\CUSHMANBW\dms34123\Plt_Joints.dgn		DRAWN -	REVISED -		SCALE:	SHEET NO.	OF	SHEETS	STA.	TO STA.	742	37R-3	OGLE	345	155
		PLLOT SCALE = 20.0000' / IN.	CHECKED -		REVISED -							CONTRACT NO. 84788			
		PLLOT DATE = Fri May 01 08:22:31 2009	DATE -		REVISED -							FED. ROAD DIST. NO. ILLINOIS FED. AID PROJECT			

PAVEMENT JOINTS

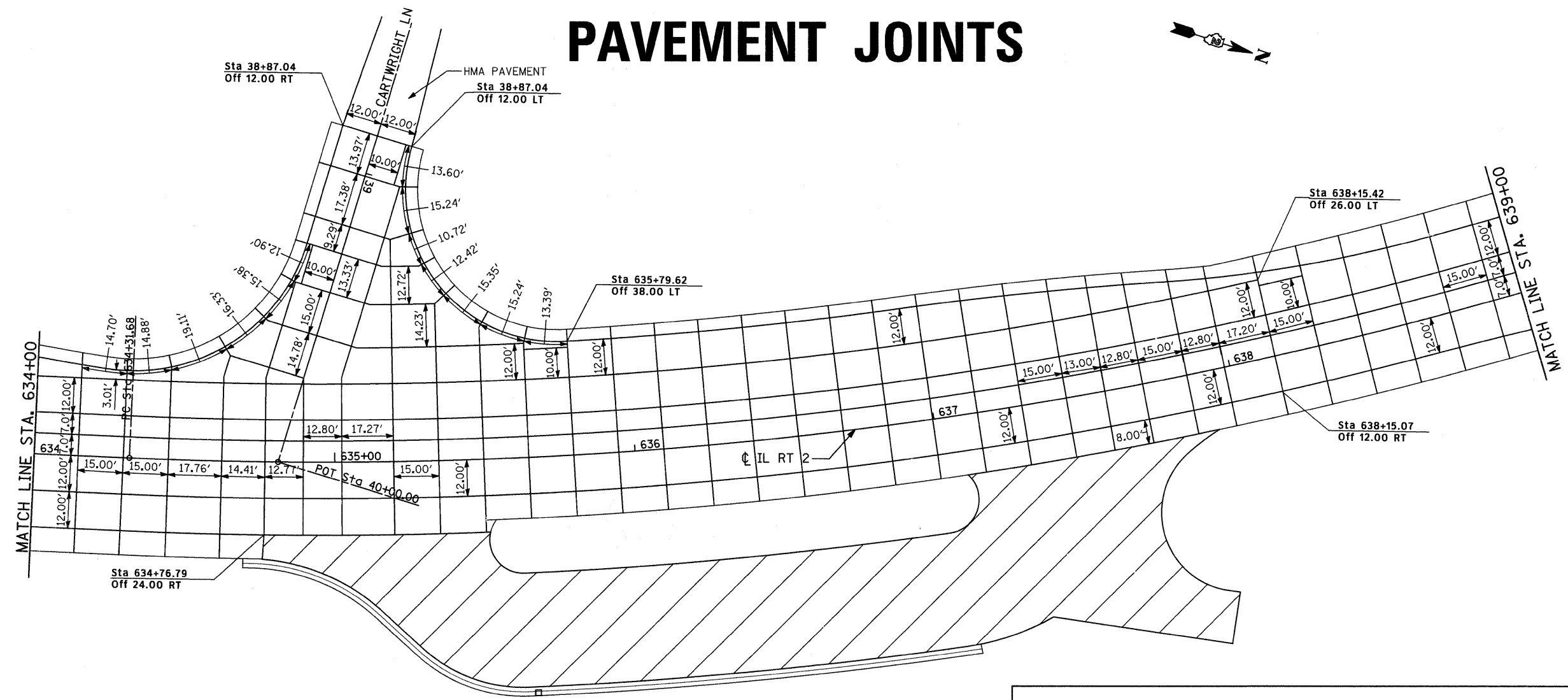

 Incidental Hot-Mix Asphalt Surfacing

NOTE:
DIMENSIONS SHOWN ON CURVES
ARE ALONG CENTERLINE, EDGE
OF PAVEMENT DIMENSIONS
BETWEEN JOINTS WILL VARY.

NOTE:
DIMENSIONS SHOWN ON CURVES
ARE ALONG CENTERLINE, EDGE
OF PAVEMENT DIMENSIONS
BETWEEN JOINTS WILL VARY.

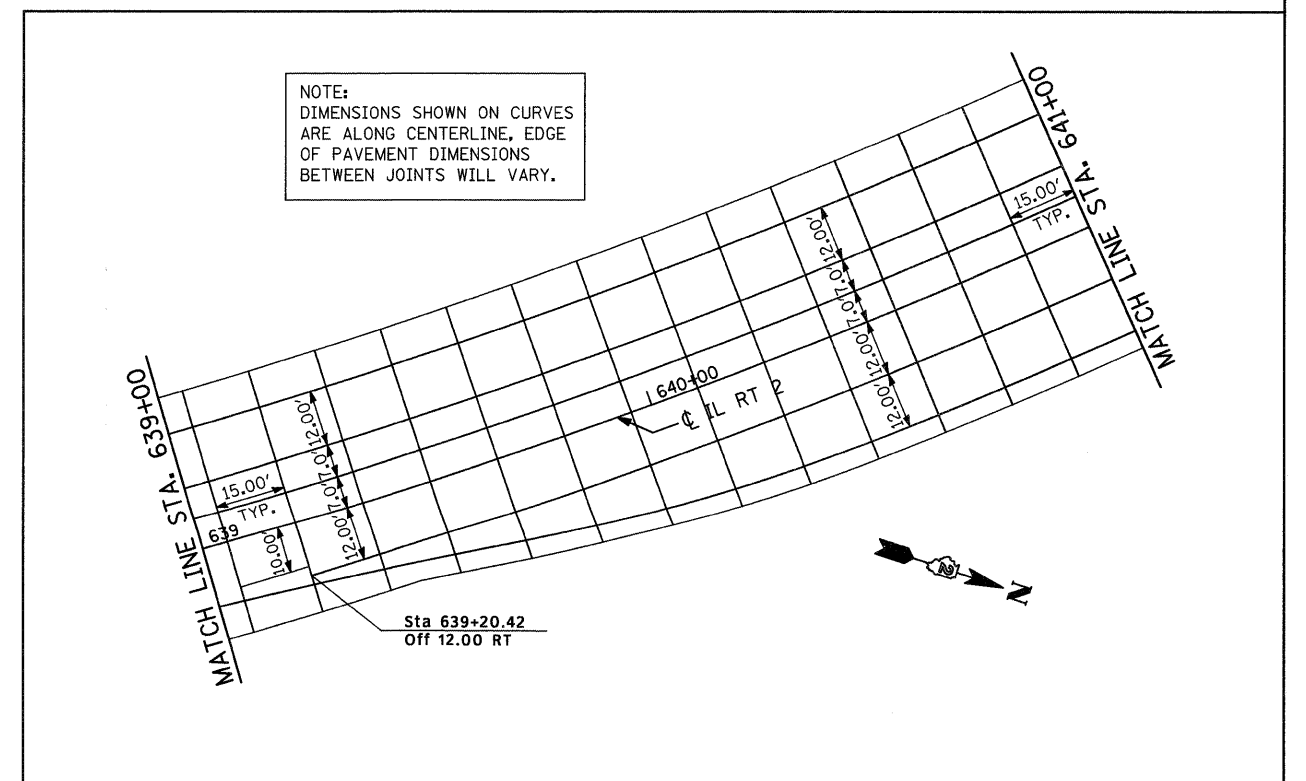

FILE NAME =	USER NAME = cushmanbw	DESIGNED -	REVISED -	STATE OF ILLINOIS DEPARTMENT OF TRANSPORTATION	PAVEMENT JOINTS				F.A.P. RTE.	SECTION	COUNTY	TOTAL SHEETS	SHEET NO.		
et:\pw_work\PWIDOT\CUSHMANBW\dms34123\ Pavt_Joints.dgn		DRAWN -	REVISED -		SCALE:	SHEET NO.	OF	SHEETS	STA.	TO STA.	742	37R-3	OGLE	345	156
		PLOT SCALE = 20.0000' / IN.	CHECKED -		REVISED -	CONTRACT NO. 84788									
		PLOT DATE = Fri May 01 08:22:31 2009	DATE -		REVISED -	ILLINOIS FED. AID PROJECT									

PAVEMENT JOINTS

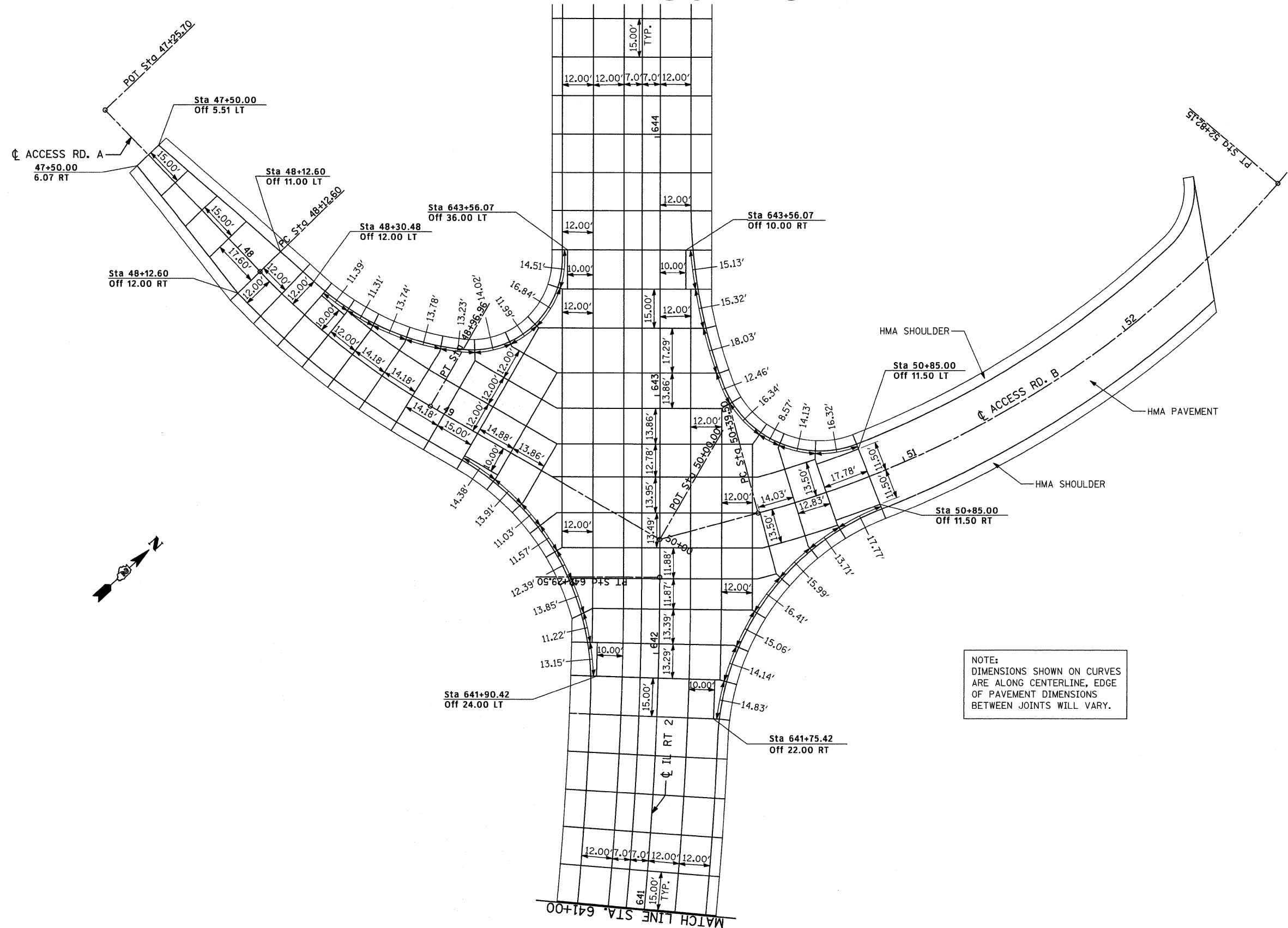

NOTE:
DIMENSIONS SHOWN ON CURVES
ARE ALONG CENTERLINE, EDGE
OF PAVEMENT DIMENSIONS
BETWEEN JOINTS WILL VARY.

FILE NAME =	USER NAME = cushmanbw	DESIGNED -	REVISED -	STATE OF ILLINOIS DEPARTMENT OF TRANSPORTATION	PAVEMENT JOINTS				F.A.P. RTE.	SECTION	COUNTY	TOTAL SHEETS	SHEET NO.		
c:\pwork\FWIDOT\CUSHMANBW\dms34123\pvt.Joints.dgn		DRAWN -	REVISED -		SCALE:	SHEET NO.	OF	SHEETS	STA.	TO STA.	742	37R-3	OGLE	345	157
PLOT SCALE = 28.0000' / IN.		CHECKED -	REVISED -												
PLOT DATE = Fri May 01 08:22:32 2009		DATE -	REVISED -												
											CONTRACT NO. 84788			ILLINOIS FED. AID PROJECT	

PAVEMENT JOINTS

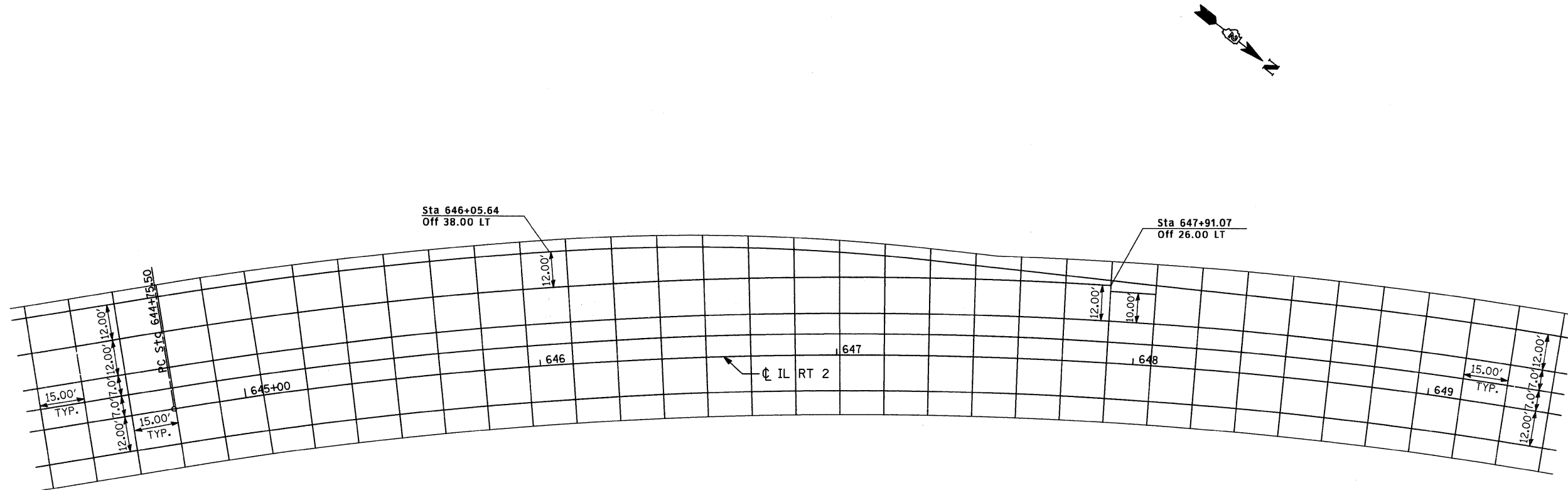

NOTE:
DIMENSIONS SHOWN ON CURVES
ARE ALONG CENTERLINE, EDGE
OF PAVEMENT DIMENSIONS
BETWEEN JOINTS WILL VARY.

FILE NAME =	USER NAME = cushmanbw	DESIGNED -	REVISED -	STATE OF ILLINOIS DEPARTMENT OF TRANSPORTATION	PAVEMENT JOINTS				F.A.P. RTE.	SECTION	COUNTY	TOTAL SHEETS	SHEET NO.		
cr\pw_work\FWIDOT\CUSHMANBW\dms34123\pvt_joints.dgn		DRAWN -	REVISED -		SCALE:	SHEET NO.	OF	SHEETS	STA.	TO STA.	742	37R-3	OGLE	345	158
		CHECKED -	REVISED -						CONTRACT NO. 84788						
		DATE -	REVISED -						FED. ROAD DIST. NO. ILLINOIS FED. AID PROJECT						

PAVEMENT JOINTS

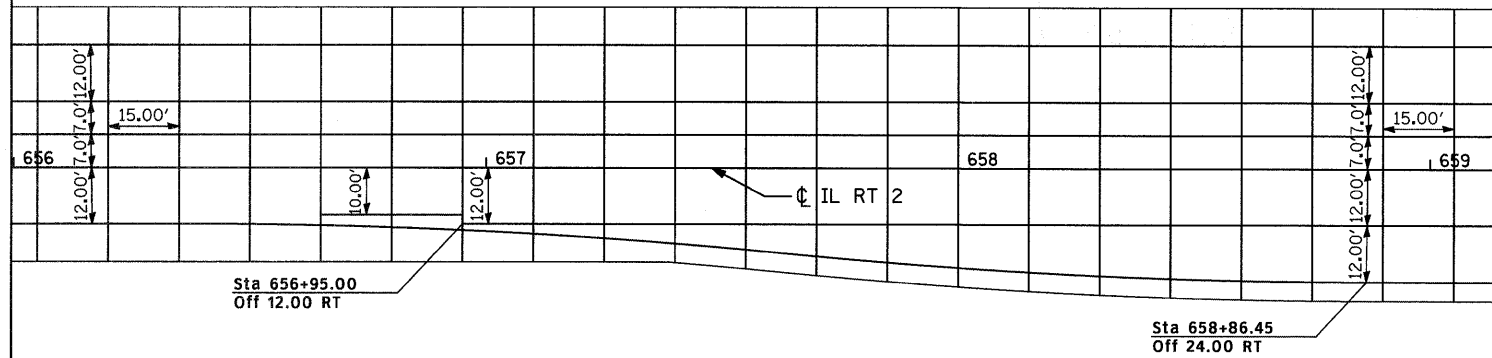

NOTE:
DIMENSIONS SHOWN ON CURVES
ARE ALONG CENTERLINE, EDGE
OF PAVEMENT DIMENSIONS
BETWEEN JOINTS WILL VARY.

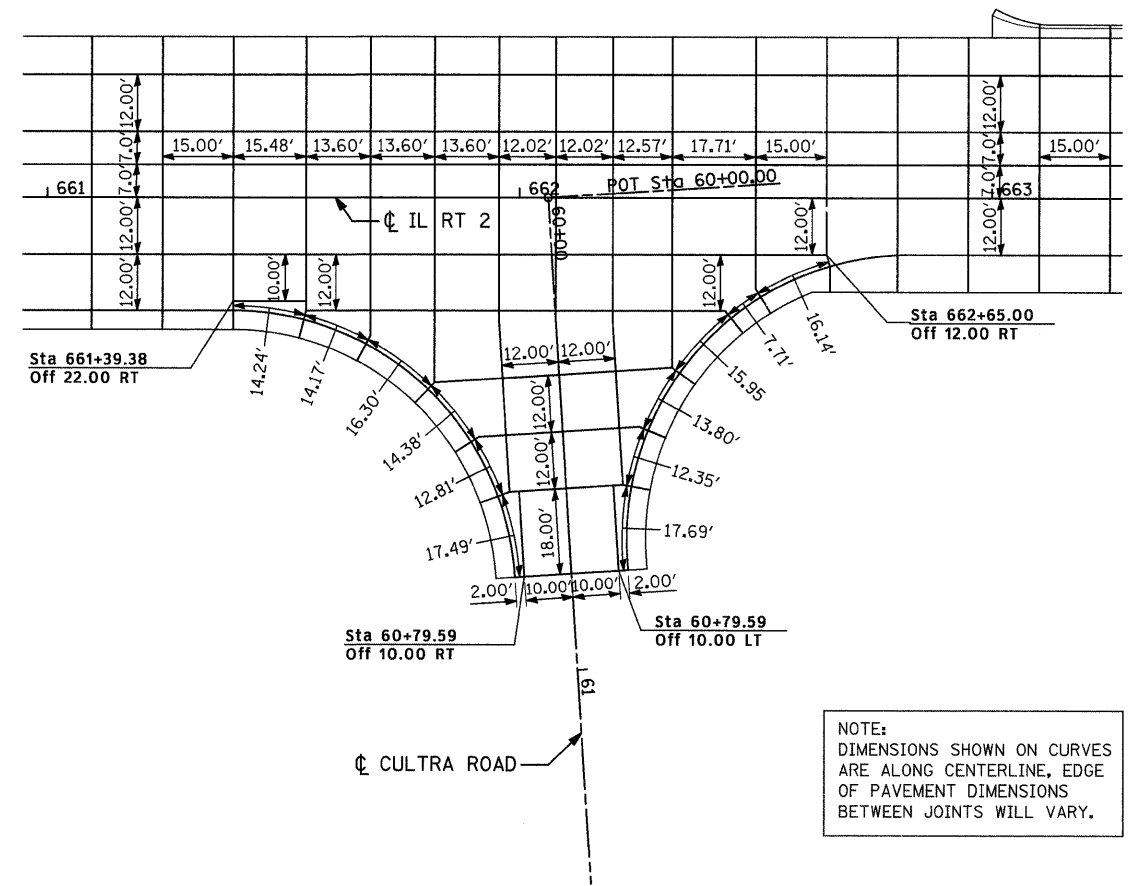

NOTE:
DIMENSIONS SHOWN ON CURVES
ARE ALONG CENTERLINE, EDGE
OF PAVEMENT DIMENSIONS
BETWEEN JOINTS WILL VARY.

FILE NAME = c:\p\work\PWIDOT\CUSHMANB\dn34123\p\rt_Joints.dgn	USER NAME = cushmanbw	DESIGNED -	REVISED -	STATE OF ILLINOIS DEPARTMENT OF TRANSPORTATION	PAVEMENT JOINTS			F.A.P. RTE. 742	SECTION 37R-3	COUNTY OGLE	TOTAL SHEETS 345	SHEET NO. 159
PLOT SCALE = 20.0000' / IN.	CHECKED -	REVISED -	REVISED -		SCALE:	SHEET NO.	OF	SHEETS	STA.	TO STA.	CONTRACT NO. 84788	
PLOT DATE = Fri May 01 08:22:33 2009	DATE -	REVISED -	REVISED -								ILLINOIS FED. AID PROJECT	
											FED. ROAD DIST. NO.	

PAVEMENT JOINTS

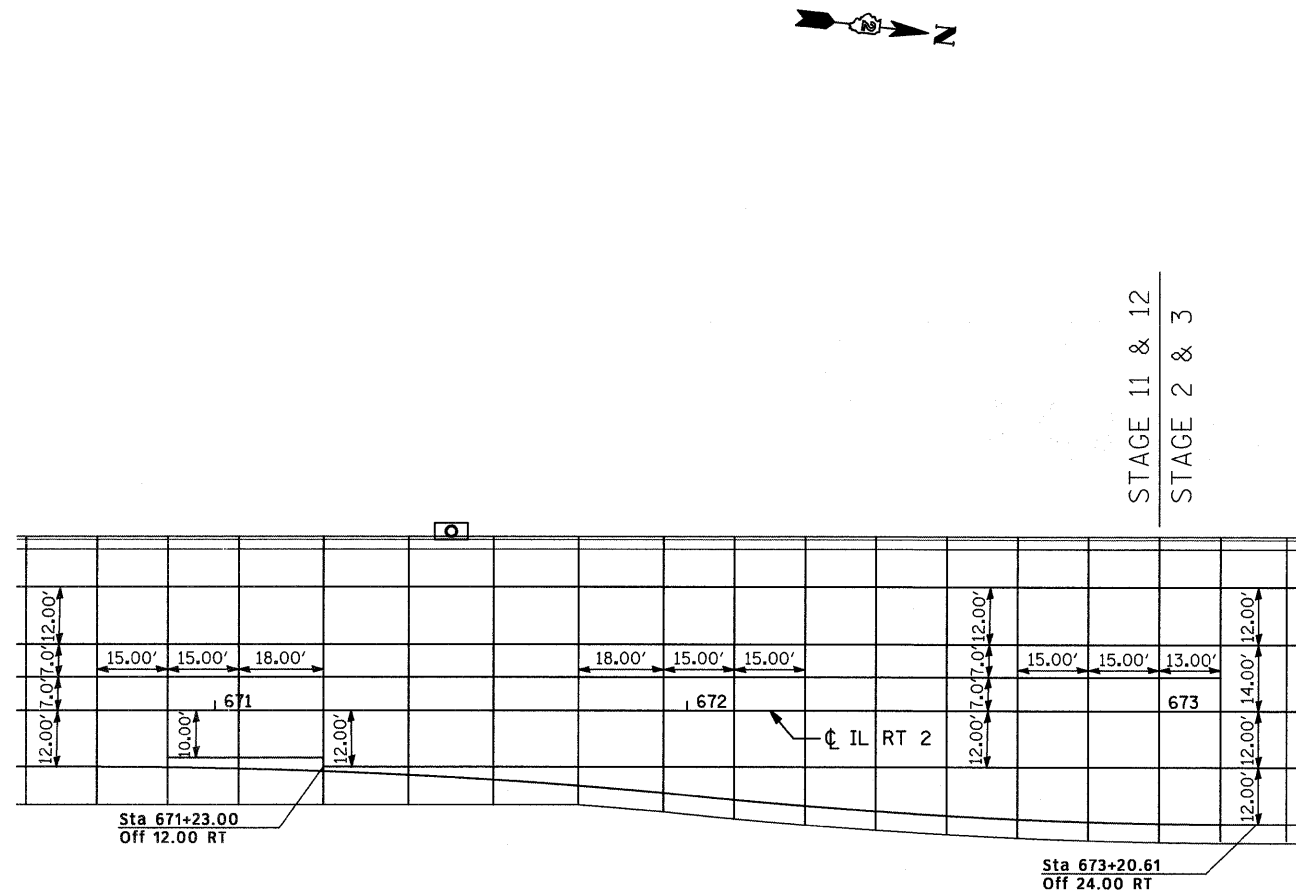

NOTE:
DIMENSIONS SHOWN ON CURVES
ARE ALONG CENTERLINE, EDGE
OF PAVEMENT DIMENSIONS
BETWEEN JOINTS WILL VARY.

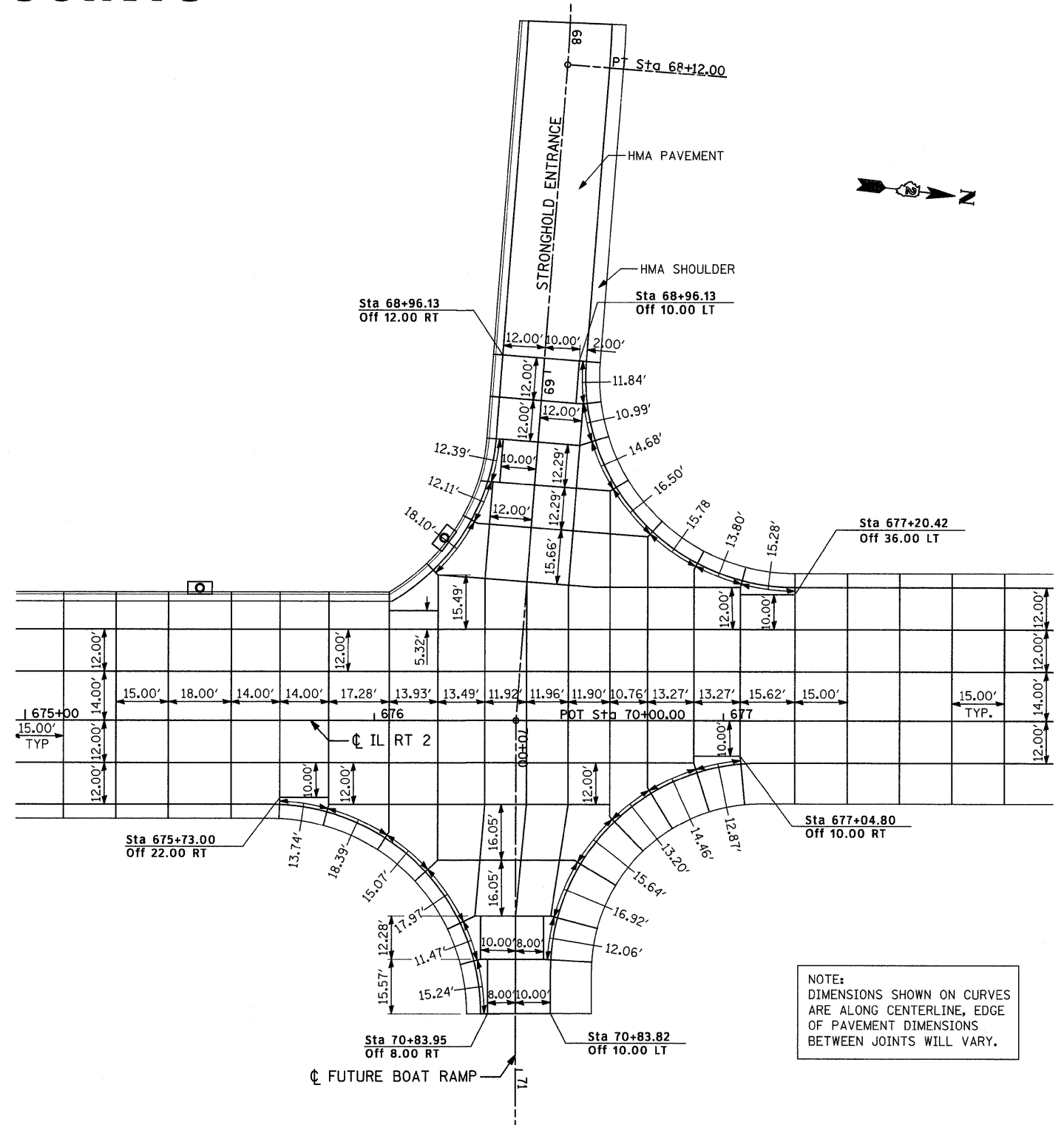

NOTE:
DIMENSIONS SHOWN ON CURVES
ARE ALONG CENTERLINE, EDGE
OF PAVEMENT DIMENSIONS
BETWEEN JOINTS WILL VARY.

FILE NAME =	USER NAME = cushmanbw	DESIGNED -	REVISED -
c:\pwork\PWIDOT\CUSHMANBW\dms34123\Pl	vt_Joints.dgn	DRAWN -	REVISED -
	PLOT SCALE = 20.0000' / IN.	CHECKED -	REVISED -
	PLOT DATE = Fri May 01 08:22:33 2009	DATE -	REVISED -

STATE OF ILLINOIS
DEPARTMENT OF TRANSPORTATION

PAVEMENT JOINTS

SCALE: SHEET NO. OF SHEETS STA. TO STA.

F.A.P. RTE.	SECTION	COUNTY	TOTAL SHEETS	SHEET NO.
742	37R-3	OGLE	345	160
CONTRACT NO. 84788				
FED. ROAD DIST. NO.		ILLINOIS FED. AID PROJECT		

Benchmark: Cross-cut in Headwall Sta. 635+49.93, 28.32' Rt. Elev. = 680.1680
Existing Structure: None

STATE OF ILLINOIS
DEPARTMENT OF TRANSPORTATION

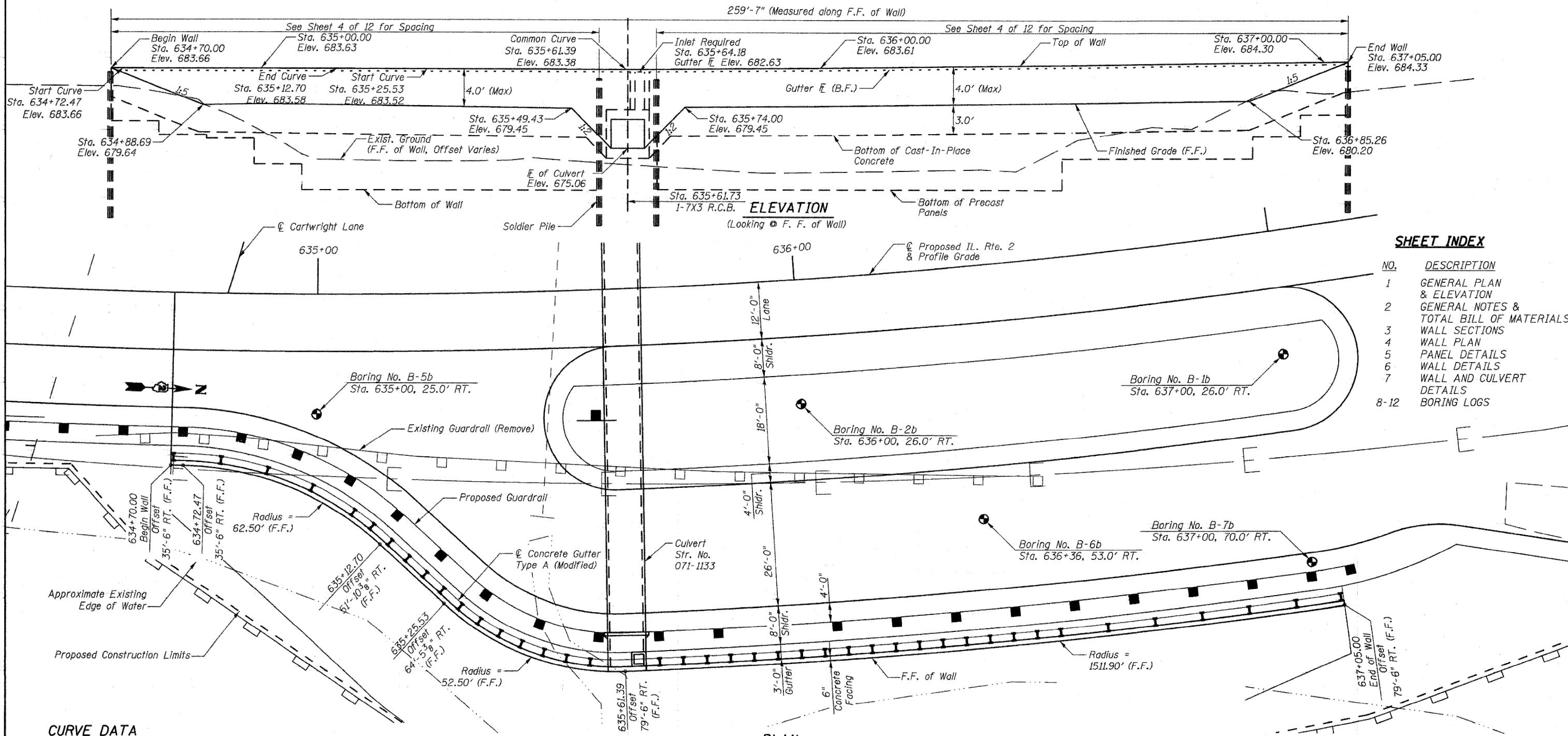

SHEET INDEX

NO.	DESCRIPTION
1	GENERAL PLAN & ELEVATION
2	GENERAL NOTES & TOTAL BILL OF MATERIALS
3	WALL SECTIONS
4	WALL PLAN
5	PANEL DETAILS
6	WALL DETAILS
7	WALL AND CULVERT DETAILS
8-12	BORING LOGS

CURVE DATA
(IL. Rte. 2)

P.I. STA = 638+41.23
Δ = 31° 54' 45.88" (LT.)
D = 3° 59' 59.99"
R = 1,432.40'
T = 409.55'
L = 797.82'
E = 57.40'
P.C. STA = 634+31.68
P.T. STA = 642+29.50

DESIGNED	DFM
CHECKED	DSG
DRAWN	EBS
CHECKED	DFM

DAVID F. MAXWELL
081-005455
ST. LOUIS, MO.

David F. Maxwell
David F. Maxwell, S.E.
Date: 3/25/09
My registration expires November 30, 2010.

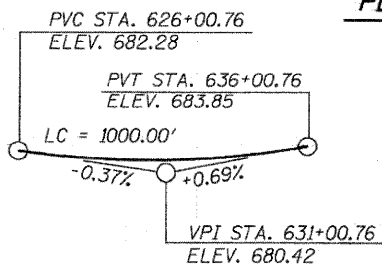

PROFILE GRADE
(Along \odot Proposed IL. Rte. 2)

Howard R. Green Company

PLAN

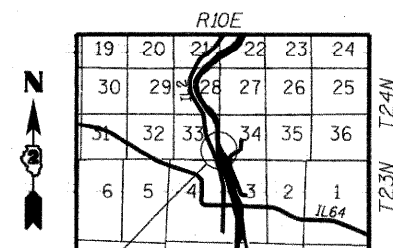

NOTES

Offsets are measured from the \odot IL. Rte. 2 to the front face of wall.
See Sheet 2 of 12 for General Notes & Total Bill of Materials.
F.F. = Front Face
B.F. = Back Face

GENERAL PLAN & ELEVATION
IL. RTE. 2
RETAINING WALL B
STA. 634+70.00 TO STA. 637+05.00

SHEET NO. 1 12 SHEETS	F.A.P. RTE. 742	SECTION 37 R-3	COUNTY OGLE	TOTAL SHEETS 345	SHEET NO. 161
	SN 071-7002		CONTRACT NO. 84788		
FED. ROAD DIST. NO. 7 ILLINOIS FED. AID PROJECT					

STATE OF ILLINOIS
DEPARTMENT OF TRANSPORTATION

DESIGN SPECIFICATIONS

2002 A.A.S.H.T.O. Specifications & Supplements

DESIGN STRESSES

Precast Units

$f_y = 60,000$ psi

$f'_c = 5,000$ psi (Precast)

Field Units

$f_y = 60,000$ psi (Reinforcement)

$f_y = 50,000$ psi (AASHTO M270 Gr. 50)

HIGHWAY CLASSIFICATION

F.A.P. Rte. 742 - IL. Rte. 2

Functional Class: Other Principal Arterial

ADT: 8,950 (2005) ; 10,350 (2025)

DHV: 1035 (2025)

Design Speed:

50 m.p.h. (Sta. 614+90 to 643+30)

Posted Speed:

50 m.p.h. (Sta. 614+90 to 643+30)

TOTAL BILL OF MATERIALS

DESCRIPTION	QUANTITY	UNITS
Concrete Structures	Cu. Yd.	43.2
Reinforcement Bars	Pound	6350
Pipe Underdrains for Structures, 4"	Foot	253
Concrete Gutter, Type A (Modified)	Foot	260
Furnishing Soldier Piles (HP Section)	Foot	1629
Geocomposite Wall Drain	Sq. Yd.	189
Driving Soldier Piles	Foot	1222
Retaining Wall (Special)	Sq. Ft.	2,245
Breaker Run Crushed Stone	Ton	363

SHOULDER CROSS SLOPE

STATION	CROSS SLOPE
634+70.00	2.90%
635+00.00	4.00%
635+50.00	2.00%
637+00.00	2.00%

Shoulder cross slope should smoothly transition between stations shown above.

GENERAL NOTES

All exposed corners 90° or sharper shall be filleted with a $\frac{3}{4}$ " dressed and beveled strip.

The bars in the walls may be spliced as follows:

Bar Size Number	4	5	6	7	8
Minimum Splice Length	20"	26"	31"	43"	54"

Reinforcement Bars shall conform to the requirements of ASTM A706 Gr 60.

All construction joints shall be bonded.

Reinforcement bars designated (E) shall be epoxy coated.

Final exposed height of Retaining Wall is a maximum of 4'-0". However, portions of the exposed height during construction may exceed this height but shall be less than 7'-0". Fill must be added to both sides of wall in order to continue construction of wall and place additional panels.

Steel Pile shall be painted with an inorganic zinc rich primer/acrylic/acrylic paint system for shop and field painting except for portions below bottom of precast panels. See special provisions for Cleaning and Painting New Metal Structures.

Dewatering is the responsibility of the contractor.

Backfill of wall behind precast panels must be completed before placement of cast-in-place concrete face.

GENERAL NOTES

IL. RTE. 2

RETAINING WALL B

STA. 634+70.00 TO STA. 637+05.00

DESIGNED	CTH
CHECKED	DSG
DRAWN	EBS
CHECKED	DFM

 Howard R. Green Company

SHEET NO. 2	F.A.P. RTE.	SECTION	COUNTY	TOTAL SHEETS	SHEET NO.
	742	37 R-3	OGLE	345	162
12 SHEETS	SN 071-7002		CONTRACT NO. 84788		
FED. ROAD DIST. NO. 7 ILLINOIS FED. AID PROJECT					

STATE OF ILLINOIS
DEPARTMENT OF TRANSPORTATION

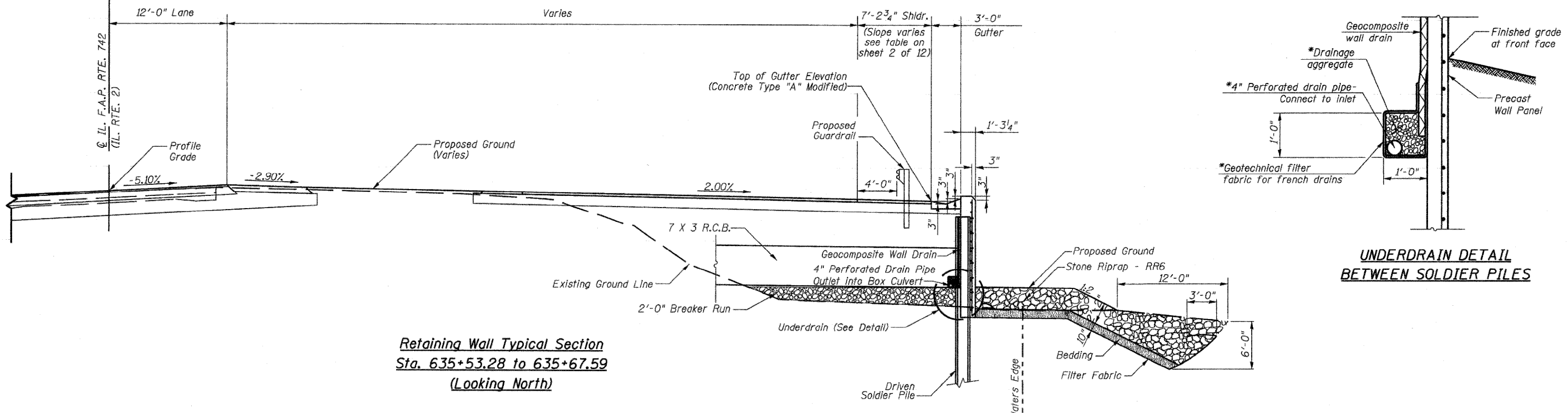
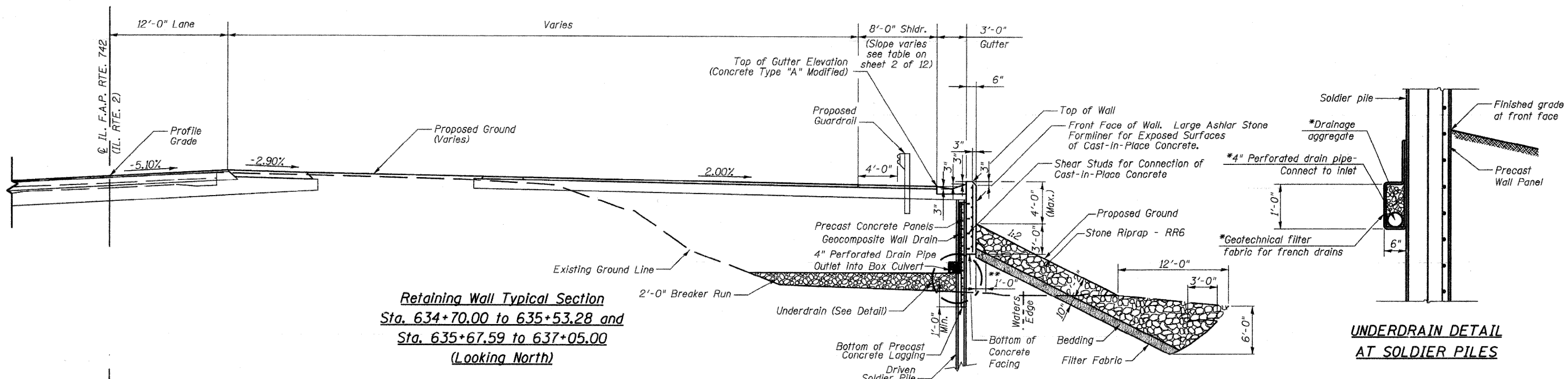

Note:
See Sheet 4 of 12 for H-Pile location and spacing.
* Included in the cost of pipe underdrains for structures.
** Exposed height of precast panels shall not exceed 7'-0" during construction of wall. Fill shall be placed on both sides of wall in order to place additional panels.

WALL SECTIONS
IL. RTE. 2
RETAINING WALL B
STA. 634+70.00 TO STA. 637+05.00

DESIGNED	DFM
CHECKED	DSG
DRAWN	DSG
CHECKED	DFM

Howard R. Green Company

SHEET NO. 3 12 SHEETS	F.A.P. RTE. 742	SECTION 37 R-3	COUNTY OGLE	TOTAL SHEETS 345	SHEET NO. 163
	SN 071-7002		CONTRACT NO. 84788		
FED. ROAD DIST. NO. 7 ILLINOIS FED. AID PROJECT					

STATE OF ILLINOIS
DEPARTMENT OF TRANSPORTATION

NOTES

Offsets are measures from the @ IL. Rte. 2 to the front face of wall.

F.F. = Front Face
B.F. = Back Face

* Field cut bars as needed to fit section.
** Field cut bars & use remaining balance in opposite end.

PANEL	NOMINAL SIZE	NO.	SF PANELS
C	2x5	49	490
D	3x5	117	1755
TOTAL		166	2245

BILL OF MATERIAL

Bar	No.	Size	Length	Shape
h	144	#5	9'-9"	—
h ₁	8	#5	7'-3"	—
h ₂	8	#5	12'-3"	—
h ₃	6	#5	14'-9"	—
h ₄	3	#5	16'-9"	—
h ₅	2	#5	15'-0"	—
v	219	#5	6'-9"	—
v ₁	16	#5	8'-6"	—
Reinforcement Bars		Pound	3,490	
Concrete Structures		Cu. Yd.	29	

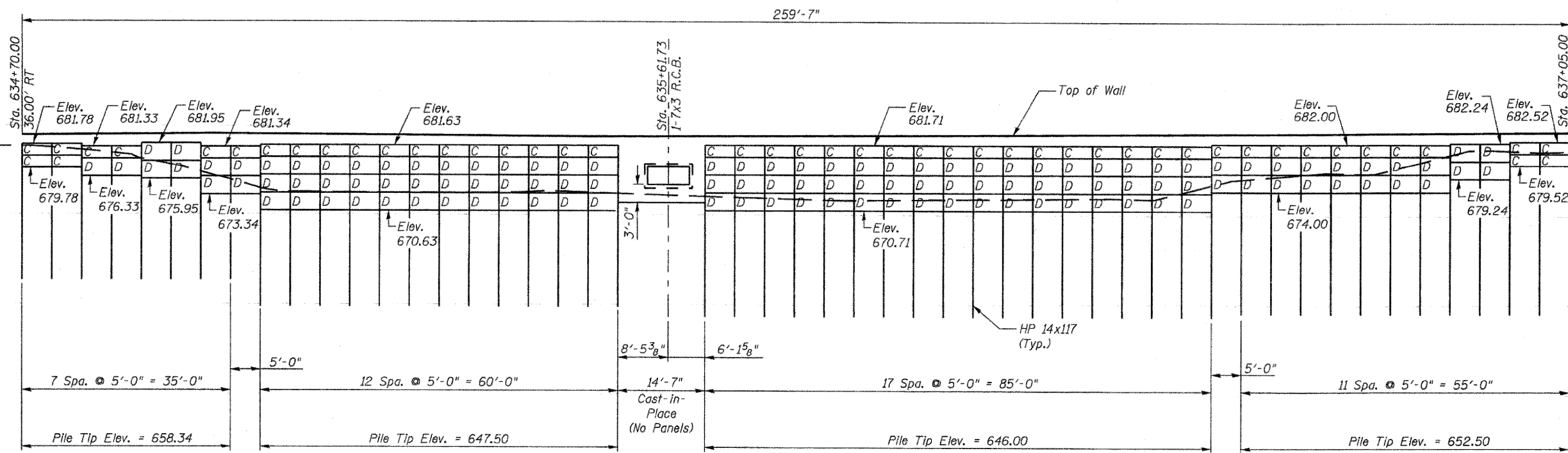

WALL ELEVATION
Precast Panels

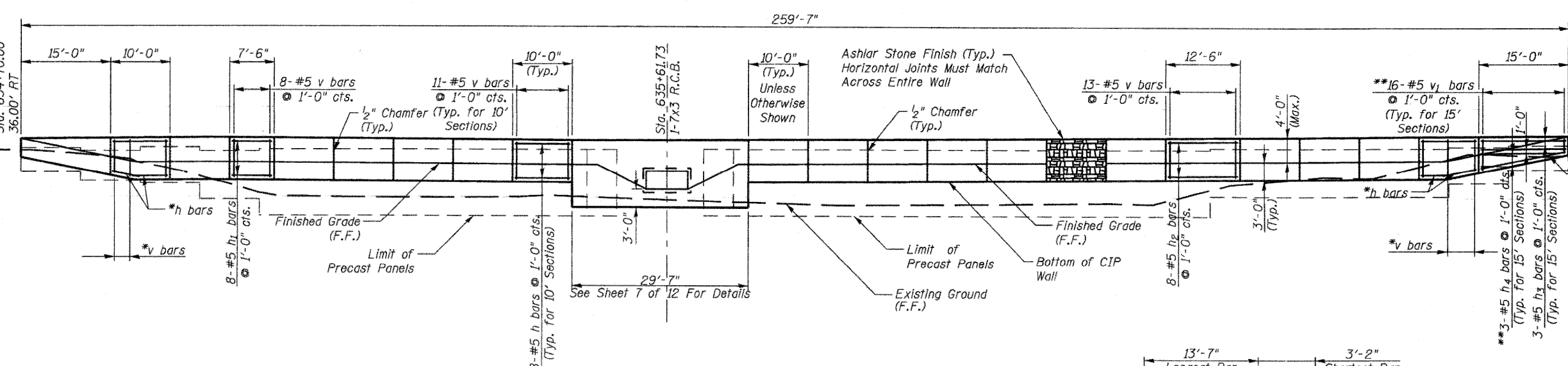

WALL ELEVATION
Cast-In-Place
(Piles Not Shown)

BAR v₁ CUT DIAGRAM

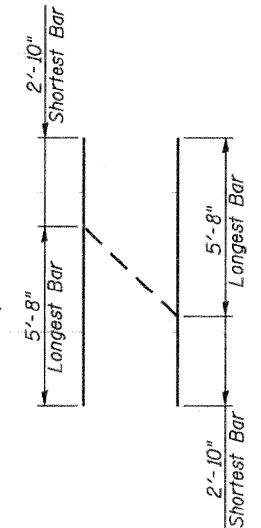

BAR h₄ CUT DIAGRAM

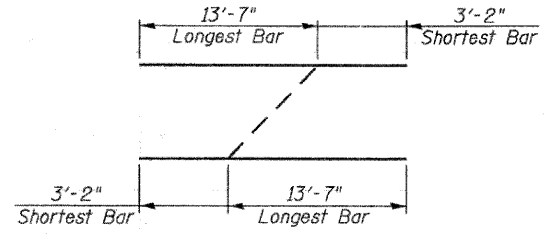

WALL PLAN
IL. RTE. 2
RETAINING WALL B

STA. 634+70.00 TO STA. 637+05.00

DESIGNED	DFM
CHECKED	DSG
DRAWN	EBS
CHECKED	DFM

SHEET NO. 4 12 SHEETS	F.A.P. RTE. 742	SECTION 37 R-3	COUNTY OGLE	TOTAL SHEETS 345	SHEET NO. 164
	SN 071-7002		CONTRACT NO. 84788		
FED. ROAD DIST. NO. 7 ILLINOIS FED. AID PROJECT					

STATE OF ILLINOIS
DEPARTMENT OF TRANSPORTATION

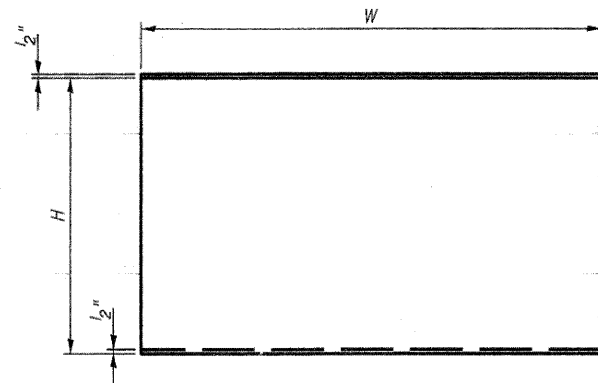

TYPICAL PANEL
ELEVATION

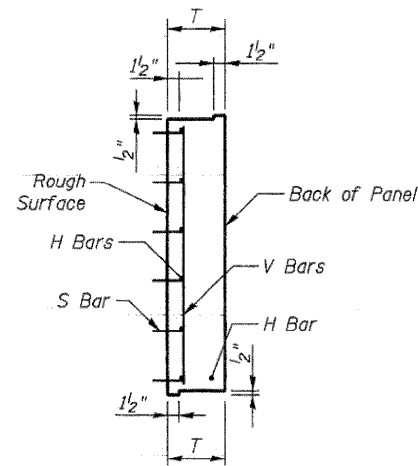

PANEL END VIEW

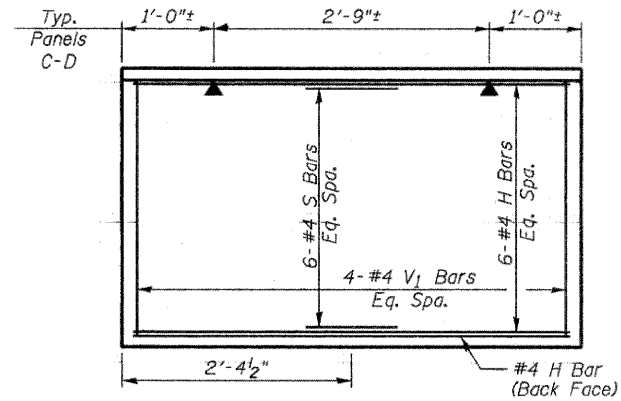

PANEL C REINFORCEMENT

*Reinforcement Quantities for information only.
Reinforcement and concrete for panels are
included in the Pay Item "Retaining Wall (Special)."

*BILL OF MATERIAL

BAR	NO.	SIZE	LENGTH	SHAPE
H	1045	#4	4'-6"	—
S	879	#4	2'-4"	—
V	468	#4	1'-9"	—
V ₁	196	#4	2'-9"	⤴
Reinforcement Bars			Pound	5,420
Concrete Structures			Cu. Yd.	52

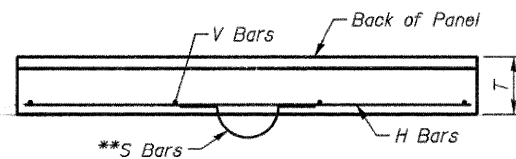

PANEL TOP VIEW

**Embedded Connection Device
(See Precast Wall Panels Special Provision)

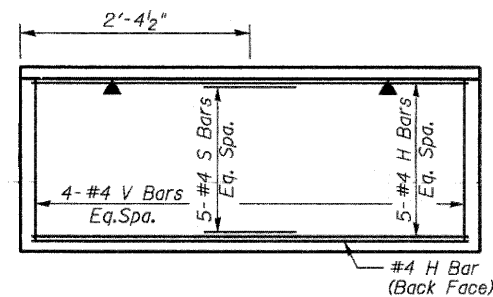

PANEL D REINFORCEMENT

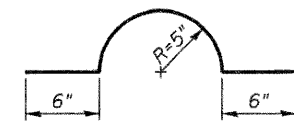

** S BAR

PANEL	H	W	T
C	2'-11 ³ / ₄ "	4'-9"	7 ¹ / ₂ "
D	1'-11 ³ / ₄ "	4'-9"	7 ¹ / ₂ "

DESIGNED	DFM
CHECKED	DSG
DRAWN	EBS
CHECKED	DFM

PANEL DETAILS
IL. RTE. 2
RETAINING WALL B
STA. 634+70.00 TO STA. 637+05.00

SHEET NO. 5	F.A.P. RTE.	SECTION	COUNTY	TOTAL SHEETS	SHEET NO.
	742	37 R-3	OGLE	345	105
12 SHEETS	SN 071-7002		CONTRACT NO. 84788		
FED. ROAD DIST. NO. 7 ILLINOIS FED. AID PROJECT					

STATE OF ILLINOIS
DEPARTMENT OF TRANSPORTATION

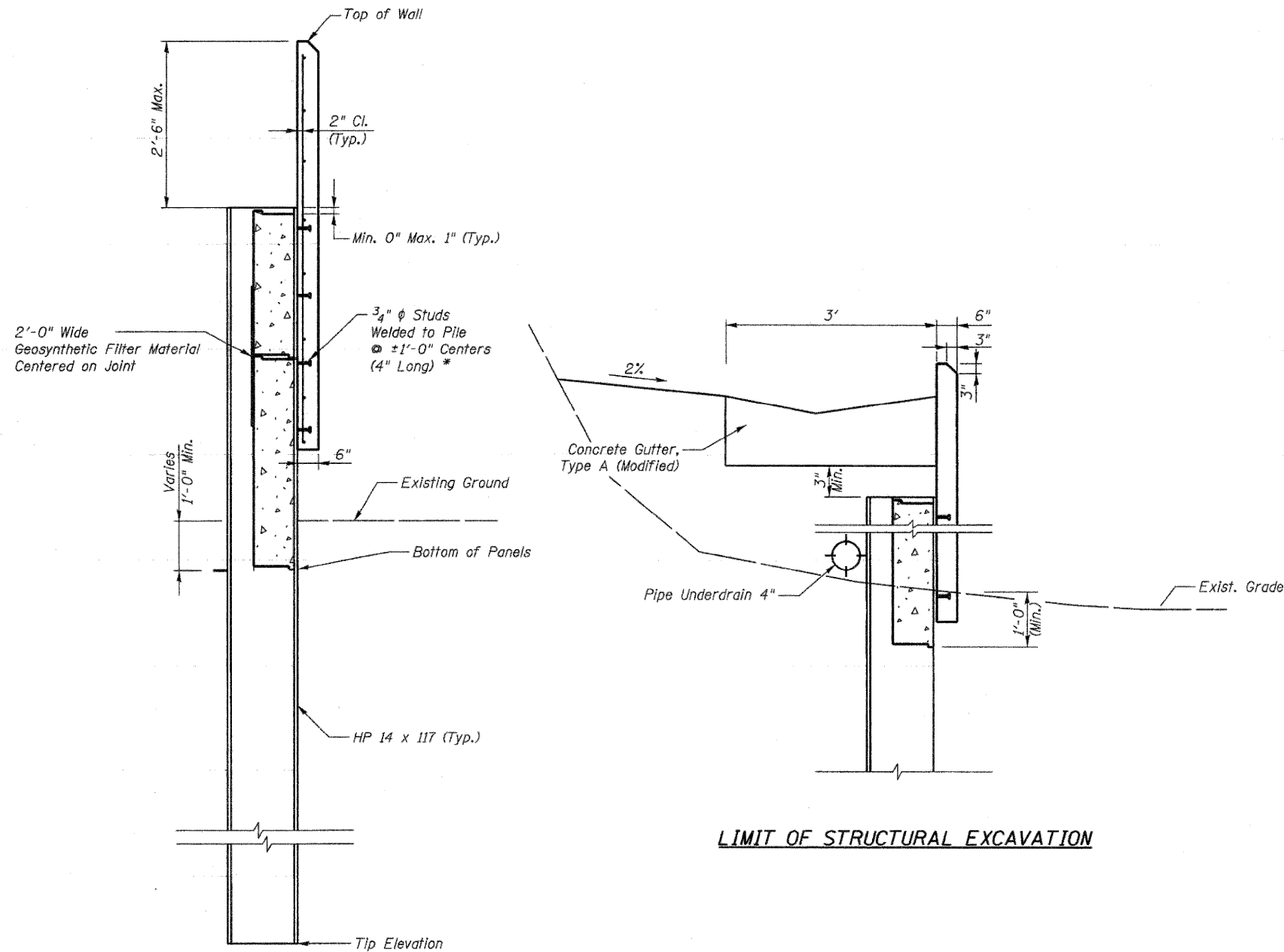

SECTION THROUGH PILE

LIMIT OF STRUCTURAL EXCAVATION

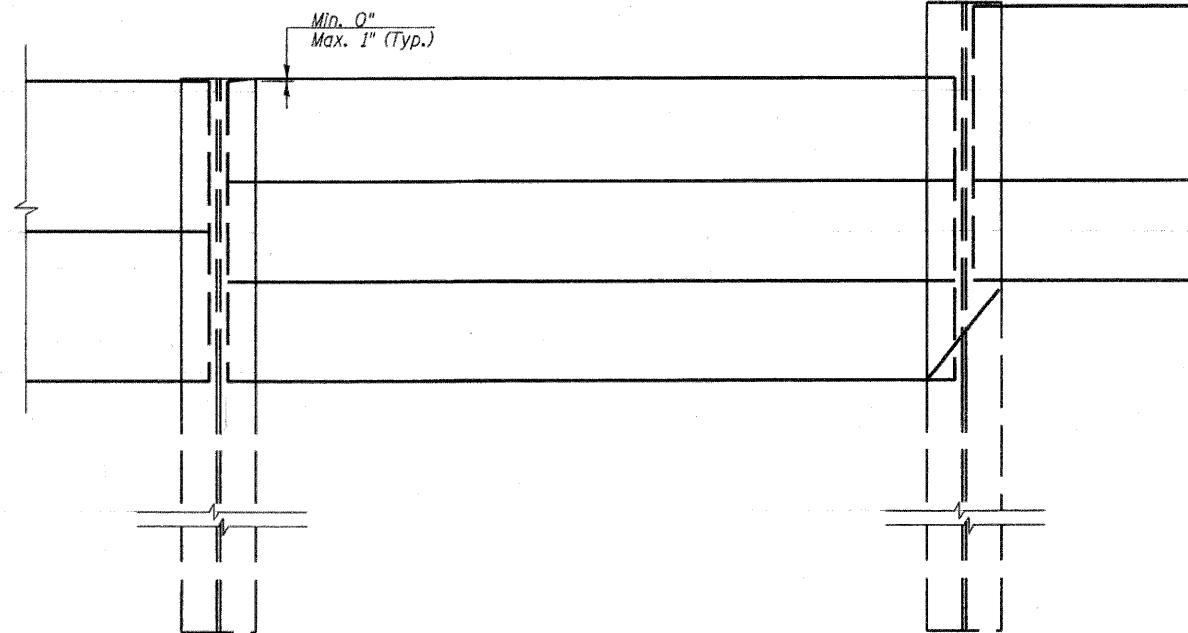

ELEVATION

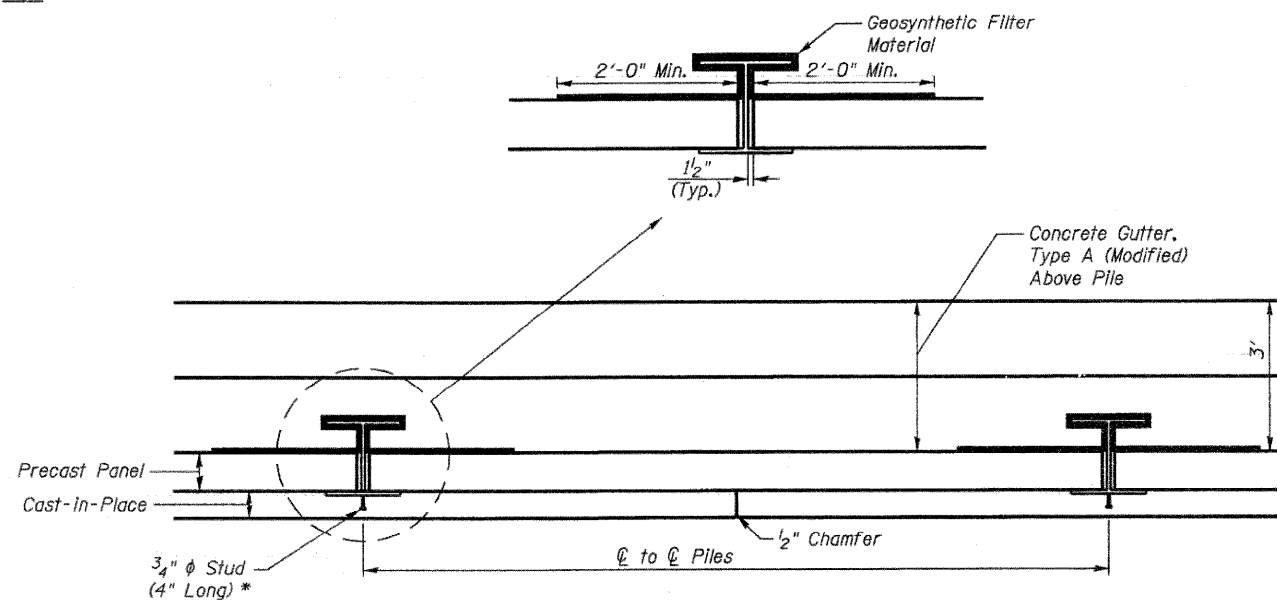

PLAN

* Incidental to "Concrete Structures"

**WALL DETAILS
IL. RTE. 2
RETAINING WALL B
STA. 634+70.00 TO STA. 637+05.00**

DESIGNED	DFM
CHECKED	DSG
DRAWN	DSG
CHECKED	DFM

SHEET NO. 6 12 SHEETS	F.A.P. RTE. 742	SECTION 37 R-3	COUNTY OGLE	TOTAL SHEETS 345	SHEET NO. 166
	SN 071-7002		CONTRACT NO. 84788		
FED. ROAD DIST. NO. 7 ILLINOIS FED. AID PROJECT					

STATE OF ILLINOIS
DEPARTMENT OF TRANSPORTATION

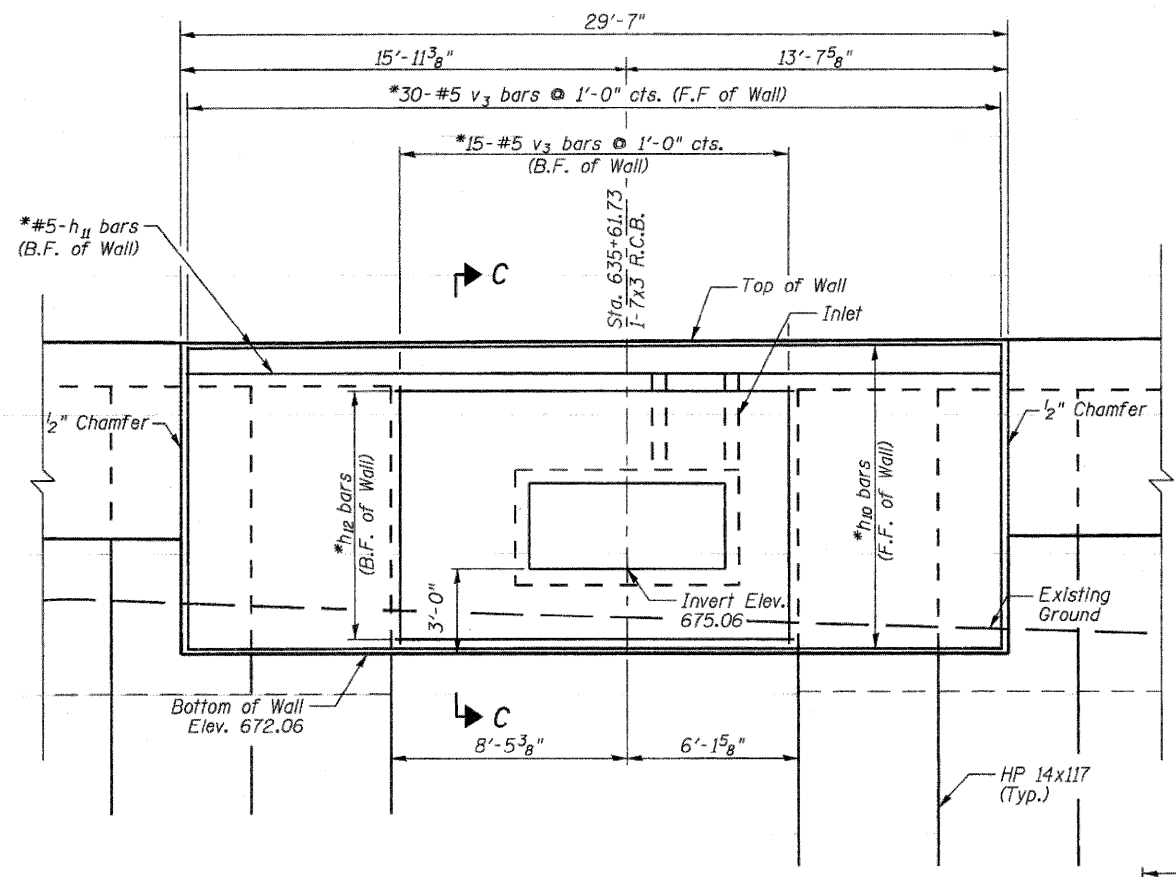

WALL ELEVATION

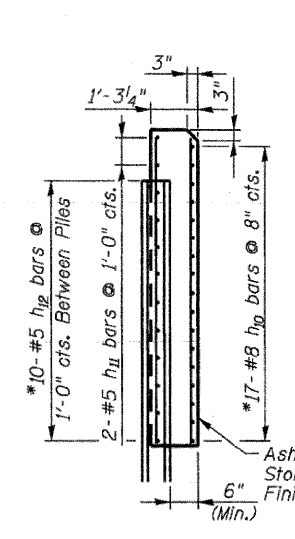

SECTION C-C

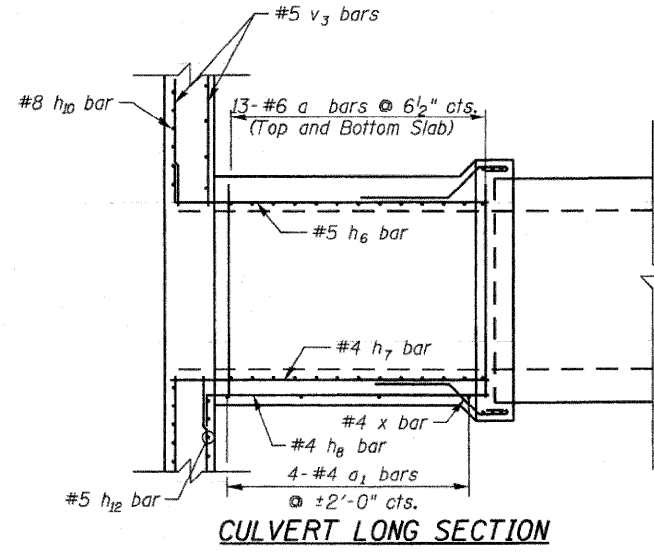

CULVERT LONG SECTION

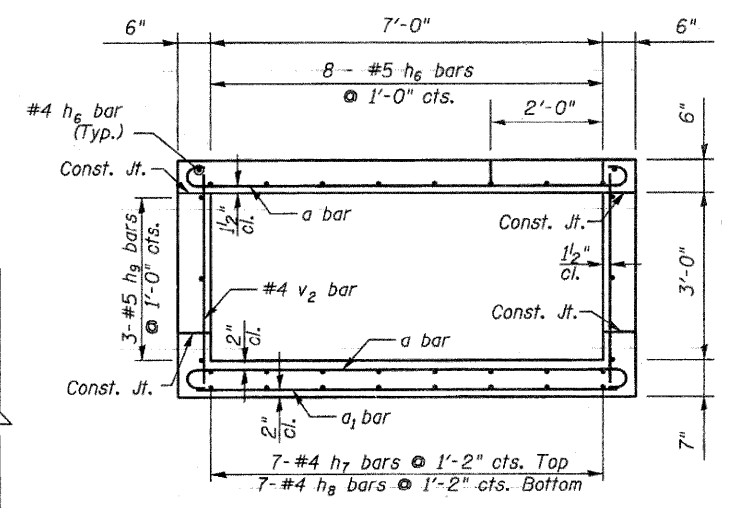

SECTION THROUGH BARREL

BILL OF MATERIAL

Bar	No.	Size	Length	Shape
a	26	#6	9'-4"	U
a1	4	#4	7'-3"	—
h6	10	#5	8'-6"	L
h7	7	#4	7'-8"	—
h8	7	#4	7'-5"	L
h9	6	#5	8'-6"	L
h10	17	#8	29'-4"	—
h11	2	#5	29'-4"	—
h12	10	#5	14'-3"	—
v2	20	#4	3'-10"	—
v3	45	#5	10'-10"	—
x	32	#4	4'-10"	U
x1	6	#4	15'-6"	L
Concrete Structures			Cu. Yd.	14.2
Reinforcement Bars			Pound	2860

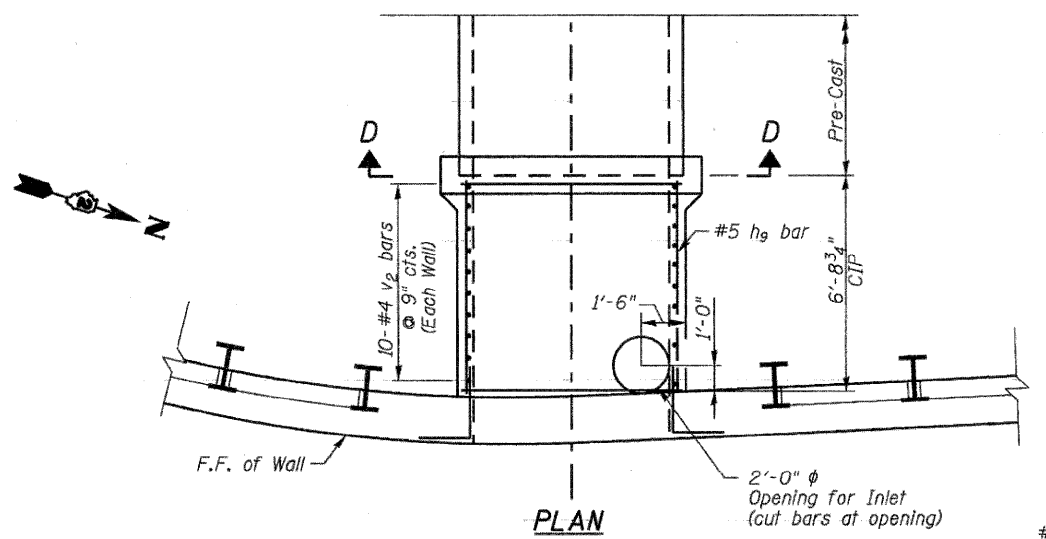

PLAN

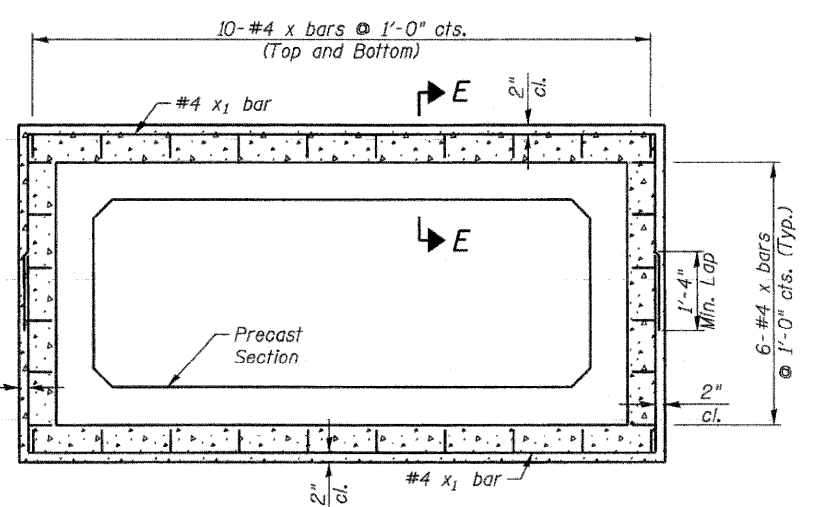

SECTION D-D

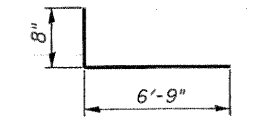

BAR h8

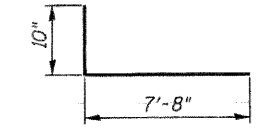

BAR h6 & h9

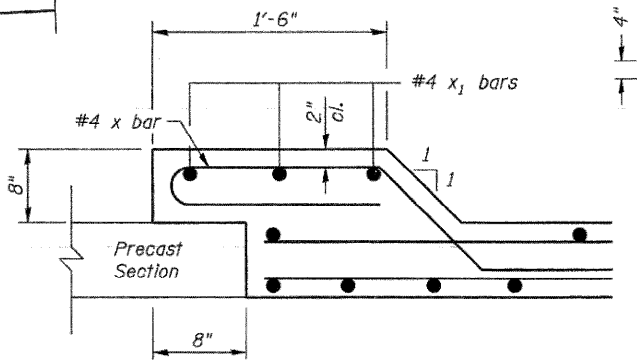

SECTION E-E

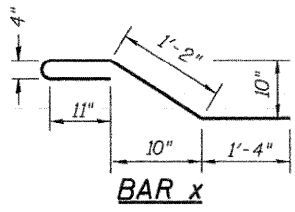

BAR x

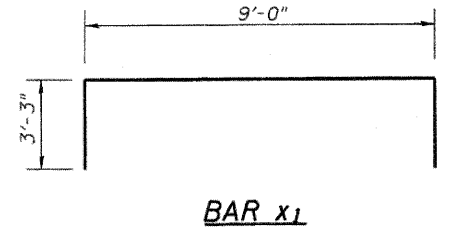

BAR x1

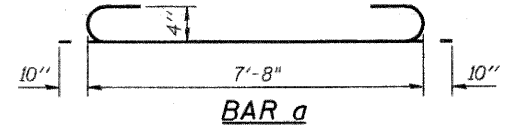

BAR a

NOTES

Offsets are measures from the @ IL. Rte. 2 to the front face of wall.
F.F. = Front Face
B.F. = Back Face
Field Cut bars intersecting Culvert and 2'-0" opening for inlet.

WALL AND CULVERT DETAILS

IL. RTE. 2
RETAINING WALL B
STA. 634+70.00 TO STA. 637+05.00

DESIGNED	DFM
CHECKED	DSG
DRAWN	EBS
CHECKED	DFM

SHEET NO. 7 12 SHEETS	F.A.P. RTE. 742	SECTION 37 R-3	COUNTY OGLE	TOTAL SHEETS 345	SHEET NO. 167
	SN 071-7002		CONTRACT NO. 84788		
FED. ROAD DIST. NO. 7 ILLINOIS FED. AID PROJECT					

STATE OF ILLINOIS
DEPARTMENT OF TRANSPORTATION



Illinois Department
of Transportation
Division of Highways
Illinois Department of Transportation D-2

SOIL BORING LOG

Page 1 of 2

Date 2/25/08

ROUTE FA 742 DESCRIPTION P02-064-86 IL 2 retaining wall, N. of Oregon
Across from Cartwright Lane LOGGED BY W. Garza
SECTION 37 R-3 LOCATION Oregon Twp. - 3 NW. SEC. , TWP. 23N. RNG. 10E
COUNTY Ogle DRILLING METHOD Hollow Stem Auger HAMMER TYPE CME-45 Automatic

STRUCT. NO. Station	D E P T H	B L O W S	U C S Qu	M O I S T	Surface Water Elev.		D E P T H	B L O W S	U C S Qu	M O I S T
					ft	ft				
BORING NO. B-1b Station 637+00 Offset 26.00R Ft. CL Ground Surface Elev. 664.30 ft					671.00					
					672.3					
6 - 8" concrete pavement beneath shoulder stone.			0.3 P	15.0			9	10		
SOFT dry brown LOAM	682.30									
VERY STIFF brown SILTY CLAY LOAM		4					8			
	680.80	5	2.9 B	20.0			14			
		7					12			
VERY STIFF brown SANDY LOAM with SAND lens		3					0			
	677.80	2	2.5 P	18.0			12			
		4					14			
MEDIUM brown dry clean medium coarse SAND	675.80	4					9			
		5					15			
		9					13			
DENSE tan dry clean medium coarse SAND	673.30	15					8			
		15					10			
		28					15			
DENSE tan clean medium coarse SAND	670.80	8					14			
		14					14			
		10					16			
DENSE tan clean medium coarse SAND	668.30	14					8			
		26					16			
		23					16			
wash MEDIUM tan SANDY GRAVEL	665.80	7					9			
		5					9			
		8					9			
MEDIUM tan SANDY GRAVEL		4					6			

The Unconfined Compressive Strength (UCS) Failure Mode is indicated by (B-Bulge, S-Shear, P-Penetrometer)
The SPT (N value) is the sum of the last two blow values in each sampling zone (AASHTO T206)
BBS, from 137 (Rev. 8-99)



Illinois Department
of Transportation
Division of Highways
Illinois Department of Transportation D-2

SOIL BORING LOG

Page 2 of 2

Date 2/25/08

ROUTE FA 742 DESCRIPTION P02-064-86 IL 2 retaining wall, N. of Oregon
Across from Cartwright Lane LOGGED BY W. Garza
SECTION 37 R-3 LOCATION Oregon Twp. - 3 NW. SEC. , TWP. 23N. RNG. 10E
COUNTY Ogle DRILLING METHOD Hollow Stem Auger HAMMER TYPE CME-45 Automatic

STRUCT. NO. Station	D E P T H	B L O W S	U C S Qu	M O I S T	Surface Water Elev.		D E P T H	B L O W S	U C S Qu	M O I S T
					ft	ft				
BORING NO. B-1b Station 637+00 Offset 26.00R Ft. CL Ground Surface Elev. 664.30 ft					671.00					
					672.3					
Wash MEDIUM tan clean medium coarse SAND (continued)	643.30						9			
End of Boring							12			

The Unconfined Compressive Strength (UCS) Failure Mode is indicated by (B-Bulge, S-Shear, P-Penetrometer)
The SPT (N value) is the sum of the last two blow values in each sampling zone (AASHTO T206)
BBS, from 137 (Rev. 8-99)

DESIGNED	DFM
CHECKED	DSG
DRAWN	EBS
CHECKED	DFM

Howard R. Green Company

BORING LOGS
IL. RTE. 2
RETAINING WALL B
STA. 634+70.00 TO STA. 637+05.00

SHEET NO. 8 12 SHEETS	F.A.P. RTE. 742	SECTION 37 R-3	COUNTY OGLE	TOTAL SHEETS 345	SHEET NO. 168
	SN 071-7002		CONTRACT NO. 84788		
FED. ROAD DIST. NO. 7 ILLINOIS FED. AID PROJECT					

STATE OF ILLINOIS
DEPARTMENT OF TRANSPORTATION



SOIL BORING LOG

Page 1 of 2

ROUTE FA 742 DESCRIPTION P92-064-86 IL 2 retaining wall, N. of Oregon across from Cartwright Lane LOGGED BY W. Garza
SECTION 37 RS-3 LOCATION Oregon Twp. -3 NW, SEC. 24N, R9G. 10E
COUNTY Ogle DRILLING METHOD Hollow Stem Auger HAMMER TYPE CME-45 Automatic

STRUCT. NO. Station	D E P T H	B L O W S	U C S	M O D E	Surface Water Elev. Stream Bed Elev.	D E P T H	B L O W S	U C S	M O D E
BORING NO. B-2b Station 636+00 Offset 26.00 ft R/L CL Ground Surface Elev. 683.30									
MEDIUM brown SILTY CLAY LOAM			0.5	17.0					
MEDIUM tan LOAM	681.30	13							
	678.80	9		13.0					
STIFF brown SANDY LOAM		3	1.5	14.0					
	676.20	2							
MEDIUM/DENSE tan dry clean medium coarse SAND		7							
	674.80	15							
DENSE tan clean medium coarse SAND		19							
	672.30	25							
		29							
MEDIUM tan clean medium coarse SAND		12							
	669.60	13							
		16							
MEDIUM tan clean medium coarse SAND with medium GRAVEL		5							
	667.30	12							
		16							
	664.80								
		6							

The Unconfined Compressive Strength (UCS) Failure Mode is indicated by (B-Bulge, S-Shear, P-Penetrometer)
The SPT (N value) is the sum of the last two blow values in each sampling zone (AASHTO T206)
BBS, from 137 (Rev. 8-99)



SOIL BORING LOG

Page 2 of 2

ROUTE FA 742 DESCRIPTION P92-064-86 IL 2 retaining wall, N. of Oregon across from Cartwright Lane LOGGED BY W. Garza
SECTION 37 RS-3 LOCATION Oregon Twp. -3 NW, SEC. 24N, R9G. 10E
COUNTY Ogle DRILLING METHOD Hollow Stem Auger HAMMER TYPE CME-45 Automatic

STRUCT. NO. Station	D E P T H	B L O W S	U C S	M O D E	Surface Water Elev. Stream Bed Elev.	D E P T H	B L O W S	U C S	M O D E
BORING NO. B-2b Station 636+00 Offset 26.00 ft R/L CL Ground Surface Elev. 683.30									
Wash MEDIUM tan clean medium coarse SAND (continued)	642.30	10							
	630.80								
Wash MEDIUM tan clean medium coarse SAND	637.30	9							
		12							
		15							
Wash DENSE tan clean medium coarse SAND	632.30	17							
		18							
		16							
End of Boring									

The Unconfined Compressive Strength (UCS) Failure Mode is indicated by (B-Bulge, S-Shear, P-Penetrometer)
The SPT (N value) is the sum of the last two blow values in each sampling zone (AASHTO T206)
BBS, from 137 (Rev. 8-99)

DESIGNED DFM
CHECKED DSG
DRAWN EBS
CHECKED DFM

Howard R. Green Company

BORING LOGS
IL. RTE. 2
RETAINING WALL B
STA. 634+70.00 TO STA. 637+05.00

SHEET NO. 9 12 SHEETS	F.A.P. RTE. 742	SECTION 37 R-3	COUNTY OGLE	TOTAL SHEETS 345	SHEET NO. 169
	SN 071-7002		CONTRACT NO. 84788		
FED. ROAD DIST. NO. 7 ILLINOIS FED. AID PROJECT					

STATE OF ILLINOIS
DEPARTMENT OF TRANSPORTATION



SOIL BORING LOG

ROUTE FA 742 DESCRIPTION P92-064-86 IL 2 retaining wall, N. of Oregon across from Cartwright Lane LOGGED BY Be. Wetzell
SECTION 37 RS-3 LOCATION Oregon Twp. - 3 NW. SEC. TWP. 23N, RNG. 10E
COUNTY Ogle DRILLING METHOD Hollow Stem Auger HAMMER TYPE B-53 Diedrich Automatic

STRUCT. NO. Station	DEPTH H	BULGE B	UCS S	MOISTURE M	Surface Water Elev. _____ ft	DEPTH H	BULGE B	UCS S	MOISTURE M
BORING NO. B-5b Station 636+00 Offset 25.00R R1 CL Ground Surface Elev. 682.20					Stream Bed Elev. _____ ft				
					Groundwater Elev.: _____ ft				
					First Encounter 672.2 ft V				
					Upon Completion wash _____ ft				
					After _____ Hrs. _____ ft				
STIFF brown SILTY LOAM			1.2	21.0	Wash _____	7			
			P		MEDIUM tan SANDY GRAVEL	9			
	679.70				660.70 11				
STIFF brown SANDY LOAM			1.7	12.0					
	678.20	4	P		MEDIUM tan SANDY GRAVEL	11			
					668.20 9				
STIFF tan SILT			1.1	23.0	Wash _____	12			
	675.20		P		MEDIUM tan SANDY GRAVEL	13			
					665.70 10				
MEDIUM tan medium SAND with GRAVEL					Wash _____	10			
	673.20				MEDIUM tan fine SAND with GRAVEL	12			
					663.20 15				
MEDIUM tan medium SAND & GRAVEL					Wash _____	10			
	670.70				MEDIUM tan SANDY GRAVEL	12			
					650.70 16				
MEDIUM tan fine SAND with GRAVEL					Wash _____	8			
	668.20				MEDIUM tan SANDY GRAVEL	9			
					648.20 11				
MEDIUM tan SANDY GRAVEL					Wash _____	13			
	665.70				MEDIUM tan SANDY GRAVEL	15			
					645.70 15				
MEDIUM tan SANDY GRAVEL					Wash _____	13			
	663.20				MEDIUM tan SANDY GRAVEL	10			
					643.20 9				
					Wash _____	10			
					643.20 9				

The Unconfined Compressive Strength (UCS) Failure Mode is indicated by (B-Bulge, S-Shear, P-Penetrometer)
The SPT (N value) is the sum of the last two blow values in each sampling zone (AASHTO T206)
BBS, from 137 (Rev. 8-99)

DESIGNED	DFM
CHECKED	DSG
DRAWN	EBS
CHECKED	DFM



SOIL BORING LOG

ROUTE FA 742 DESCRIPTION P92-064-86 IL 2 retaining wall, N. of Oregon across from Cartwright Lane LOGGED BY Be. Wetzell
SECTION 37 RS-3 LOCATION Oregon Twp. - 3 NW. SEC. TWP. 23N, RNG. 10E
COUNTY Ogle DRILLING METHOD Hollow Stem Auger HAMMER TYPE B-53 Diedrich Automatic

STRUCT. NO. Station	DEPTH H	BULGE B	UCS S	MOISTURE M	Surface Water Elev. _____ ft	DEPTH H	BULGE B	UCS S	MOISTURE M
BORING NO. B-5b Station 635+00 Offset 25.00R R1 CL Ground Surface Elev. 682.20					Stream Bed Elev. _____ ft				
					Groundwater Elev.: _____ ft				
					First Encounter 672.2 ft V				
					Upon Completion wash _____ ft				
					After _____ Hrs. _____ ft				
Wash _____					9				
MEDIUM tan SANDY GRAVEL					8				
640.70 10									
Wash _____					7				
MEDIUM tan SANDY GRAVEL					10				
638.20 14									
Wash _____					20				
DENSE tan SANDY GRAVEL					23				
635.70 19									
Wash _____					14				
MEDIUM tan SANDY GRAVEL					14				
633.20 16									
Wash _____					18				
DENSE tan SANDY GRAVEL					20				
630.70 22									
End of Boring									

The Unconfined Compressive Strength (UCS) Failure Mode is indicated by (B-Bulge, S-Shear, P-Penetrometer)
The SPT (N value) is the sum of the last two blow values in each sampling zone (AASHTO T206)
BBS, from 137 (Rev. 8-99)

**BORING LOGS
IL. RTE. 2
RETAINING WALL B
STA. 634+70.00 TO STA. 637+05.00**

SHEET NO. 10	F.A.P. RTE.	SECTION	COUNTY	TOTAL SHEETS	SHEET NO.
	742	37 R-3	OGLE	345	170
12 SHEETS	SN 071-7002		CONTRACT NO. 84788		
FED. ROAD DIST. NO. 7 ILLINOIS FED. AID PROJECT					

STATE OF ILLINOIS
DEPARTMENT OF TRANSPORTATION



Illinois Department
of Transportation
Division of Highways
Illinois Department of Transportation 10-2

SOIL BORING LOG

Page 1 of 2

ROUTE FA 742 DESCRIPTION P92-064-86 IL 2 retaining wall, N. of Oregon across from Cartwright Lane LOGGED BY W. Garza

SECTION 37 RS-3 LOCATION Oregon Twp. - 3 NW, SEC. , TWP. 24N, RNG. 10E

COUNTY Ogle DRILLING METHOD Hollow Stem Auger HAMMER TYPE CME-45 Automatic

STRUCT. NO. Station	D E P T H	B L O W S	U C S Qu	M O I S T	Surface Water Elev.		D E P T H	B L O W S	U C S Qu	M O I S T
					ft	ft				
BORING NO. B-6b Station 636+36 Offset 53.00 ft RL CL Ground Surface Elev. 681.30 ft										
MEDIUM brown SILTY CLAY LOAM			0.5 P	31.0				6		
679.30								5		
STIFF brown SILTY CLAY LOAM		4						20		
677.80		5	1.3 P	22.0				15		
		5						15		
LOOSE brown dry dirty SAND		3						13		
675.30		4						15		
		5						8		
MEDIUM tan clean medium coarse SAND		5						10		
672.80		8						11		
		12						13		
MEDIUM tan clean medium coarse SAND		6						7		
670.30		7						8		
		0						12		
MEDIUM tan clean medium coarse SAND		5						5		
667.80		6						7		
		17						9		
Same as above		11						10		
665.30		17						10		
		12						15		
Wash MEDIUM tan clean medium coarse SAND		6						10		
662.80		8						17		
		10						18		
		9						6		

The Unconfined Compressive Strength (UCS) Failure Mode is indicated by (B-Bulge, S-Shear, P-Penetrometer)
The SPT (N value) is the sum of the last two blow values in each sampling zone (AASHTO T208)
BBS, from 137 (Rev. 8-89)



Illinois Department
of Transportation
Division of Highways
Illinois Department of Transportation 10-2

SOIL BORING LOG

Page 2 of 2

ROUTE FA 742 DESCRIPTION P92-064-86 IL 2 retaining wall, N. of Oregon across from Cartwright Lane LOGGED BY W. Garza

SECTION 37 RS-3 LOCATION Oregon Twp. - 3 NW, SEC. , TWP. 24N, RNG. 10E

COUNTY Ogle DRILLING METHOD Hollow Stem Auger HAMMER TYPE CME-45 Automatic

STRUCT. NO. Station	D E P T H	B L O W S	U C S Qu	M O I S T	Surface Water Elev.		D E P T H	B L O W S	U C S Qu	M O I S T
					ft	ft				
BORING NO. B-6b Station 636+36 Offset 53.00 ft RL CL Ground Surface Elev. 681.30 ft										
Wash MEDIUM tan clean medium coarse SAND with medium GRAVEL (continued)								11		
640.30								15		
Wash DENSE tan SANDY GRAVEL								8		
637.80								16		
								15		
Wash DENSE tan SANDY GRAVEL								8		
635.30								13		
								19		
DENSE tan SANDY GRAVEL								17		
632.80								21		
								18		
Wash DENSE tan clean medium coarse SAND								15		
630.30								21		
								25		
End of Boring										

The Unconfined Compressive Strength (UCS) Failure Mode is indicated by (B-Bulge, S-Shear, P-Penetrometer)
The SPT (N value) is the sum of the last two blow values in each sampling zone (AASHTO T208)
BBS, from 137 (Rev. 8-89)

BORING LOGS
IL. RTE. 2
RETAINING WALL B
STA. 634+70.00 TO STA. 637+05.00

DESIGNED	DFM
CHECKED	DSG
DRAWN	EBS
CHECKED	DFM

Howard R. Green Company

SHEET NO. 11 12 SHEETS	F.A.P. RTE. 742	SECTION 37 R-3	COUNTY OGLE	TOTAL SHEETS 345	SHEET NO. 171
	SN 071-7002		CONTRACT NO. 84788		
FED. ROAD DIST. NO. 7 ILLINOIS FED. AID PROJECT					

STATE OF ILLINOIS
DEPARTMENT OF TRANSPORTATION



Illinois Department
of Transportation
Division of Highways
Illinois Department of Transportation 3-2

SOIL BORING LOG

Page 1 of 2

Date 3/4/08

ROUTE FA 742 DESCRIPTION P92-064-05 IL 2 retaining wall, N. of Oregon across from Cartwright Lane LOGGED BY W. Garza

SECTION 37 RS-3 LOCATION Oregon Twp. - 3 NW, SEC. , TWP. 24N, RNG. 10E

COUNTY Ogle DRILLING METHOD Hollow Stem Auger HAMMER TYPE CME-45 Automatic

STRUCT. NO. Station	BORING NO. Station Offset Ground Surface Elev.	D E P T H ft	B L O W S Qu	U C S P	M O I S T T	Surface Water Elev.		D E P T H ft	B L O W S Qu	U C S T	M O I S T T	
						ft	ft					
	B-7b 637+00 70.00 ft RL CL 682.30 ft											
				0.6 P	18.0				8 10			
			2						9 14			
			6 8	2.4 P	12.0				10 12 14			
			3 4 5						6 12 16			
			8 10						14 15 14			
			12 17 18						10 16 18			
			14 14 12						8 8 7			
			14 6 6						8 10 14			
			8						9			

The Unconfined Compressive Strength (UCS) Failure Mode is indicated by (B-Bulge, S-Shear, P-Penetrometer)
The SPT (N value) is the sum of the last two blow values in each sampling zone (AASHTO T206)
BBS, from 137 (Rev. 8-99)



Illinois Department
of Transportation
Division of Highways
Illinois Department of Transportation 3-2

SOIL BORING LOG

Page 2 of 2

Date 3/4/08

ROUTE FA 742 DESCRIPTION P92-064-05 IL 2 retaining wall, N. of Oregon across from Cartwright Lane LOGGED BY W. Garza

SECTION 37 RS-3 LOCATION Oregon Twp. - 3 NW, SEC. , TWP. 24N, RNG. 10E

COUNTY Ogle DRILLING METHOD Hollow Stem Auger HAMMER TYPE CME-45 Automatic

STRUCT. NO. Station	BORING NO. Station Offset Ground Surface Elev.	D E P T H ft	B L O W S Qu	U C S T	M O I S T T	Surface Water Elev.		D E P T H ft	B L O W S Qu	U C S T	M O I S T T	
						ft	ft					
	B-7b 637+00 70.00 ft RL CL 682.30 ft											
									11 11			
									8 13 14			
									9 10 13			
									14 19 21			

The Unconfined Compressive Strength (UCS) Failure Mode is indicated by (B-Bulge, S-Shear, P-Penetrometer)
The SPT (N value) is the sum of the last two blow values in each sampling zone (AASHTO T206)
BBS, from 137 (Rev. 8-99)

DESIGNED	DFM
CHECKED	DSG
DRAWN	EBS
CHECKED	DFM

Howard R. Green Company

SHEET NO. 12	F.A.P. RTE.	SECTION	COUNTY	TOTAL SHEETS	SHEET NO.
	742	37 R-3	OGLE	345	172
12 SHEETS	SN 071-7002		CONTRACT NO. 84788		
FED. ROAD DIST. NO. 7 ILLINOIS FED. AID PROJECT					

BORING LOGS
IL. RTE. 2
RETAINING WALL B
STA. 634+70.00 TO STA. 637+05.00

Benchmark: Railroad Spike in Tree Sta. 681+71.11, 64.04' Rt., Elev. = 675.7380
 Existing Structure: None

STATE OF ILLINOIS
 DEPARTMENT OF TRANSPORTATION

205'-2 1/4"

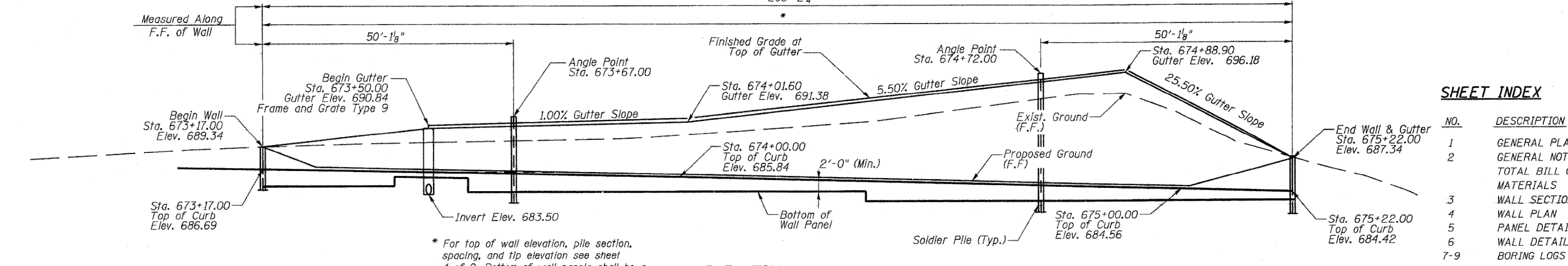

SHEET INDEX

NO.	DESCRIPTION
1	GENERAL PLAN
2	GENERAL NOTES & TOTAL BILL OF MATERIALS
3	WALL SECTION
4	WALL PLAN
5	PANEL DETAILS
6	WALL DETAILS
7-9	BORING LOGS

* For top of wall elevation, pile section, spacing, and tip elevation see sheet 4 of 9. Bottom of wall panels shall be a minimum of 2'-0" below top of curb.

ELEVATION
 (Looking @ F. F. of Wall)

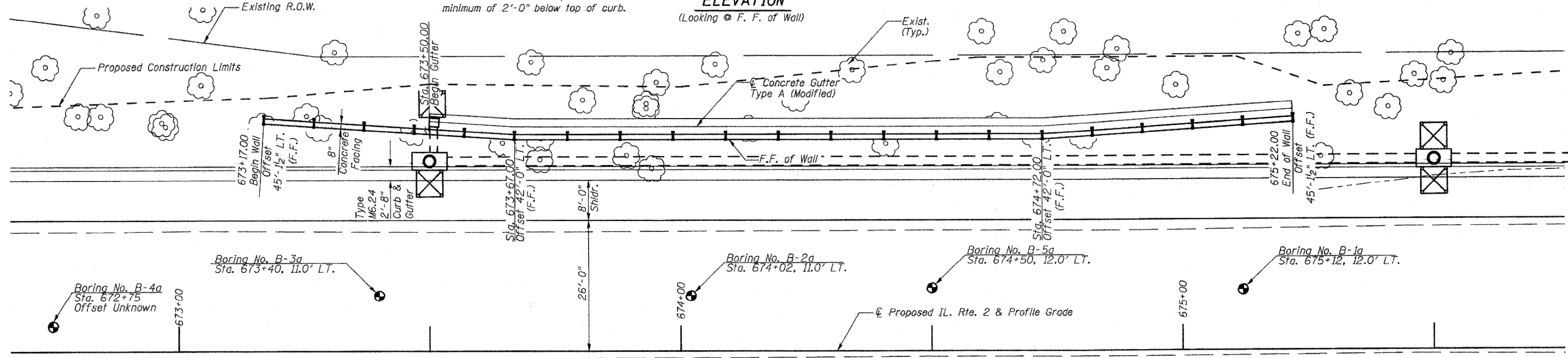

PLAN

CURVE DATA
 (IL. Rte. 2)

P.I. STA = 682+45.19
 $\Delta = 27^\circ 33' 30''$ (LT.)
 $D = 3^\circ 49' 11''$
 $R = 1,500.00'$
 $T = 367.86'$
 $L = 721.48'$
 $E = 44.45'$
 P.C. STA = 678+77.33
 P.T. STA = 685+98.81
 Wall not in Curve

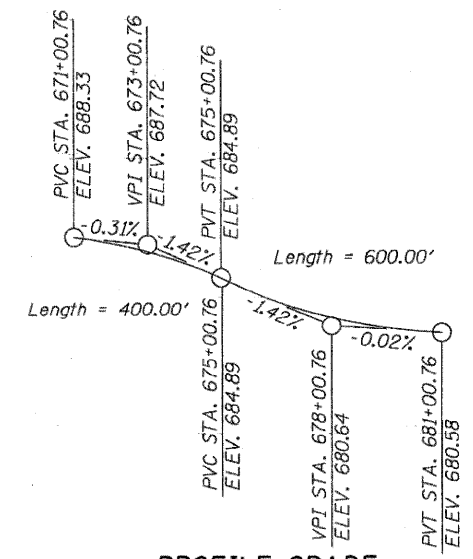

PROFILE GRADE
 (Along ϕ Proposed IL. Rte. 2)

NOTES

Offsets are measures from the ϕ IL. Rte. 2 to the front face of wall.

See sheet 2 of 9 for Bill of Materials.

F.F. = Front Face
 B.F. = Back Face

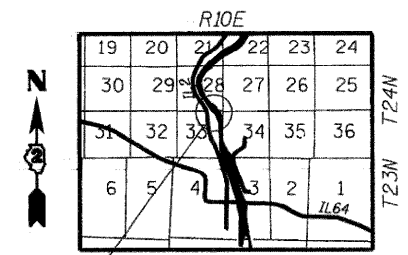

LOCATION SKETCH

David F. Maxwell, S.E.
 Reg. No. 081-005455
 Date: 3/25/09
 My registration expires November 30, 2010.

APPROVED
 FOR STRUCTURAL ADEQUACY ONLY

Ralph E. Anderson
 ENGINEER

GENERAL PLAN
IL. RTE. 2
RETAINING WALL C
STA. 673+17.00 TO STA. 675+22.00

DESIGNED	DFM
CHECKED	DSG
DRAWN	DSG
CHECKED	DFM

SHEET NO. 1	F.A.P. RTE.	SECTION	COUNTY	TOTAL SHEETS	SHEET NO.
9 SHEETS	742	37 R-3	OGLE	345	173
SN 071-7001			CONTRACT NO. 84788		
FED. ROAD DIST. NO. 7 ILLINOIS FED. AID PROJECT					

Howard R. Green Company

STATE OF ILLINOIS
DEPARTMENT OF TRANSPORTATION

DESIGN SPECIFICATIONS

2002 A.A.S.H.T.O. Specifications & Supplements

DESIGN STRESSES

Precast Units
fy = 60,000 psi
f'c = 5,000 psi (Precast)

Field Units
fy = 60,000 psi (Reinforcement)
fy = 50,000 psi (AASHTO M270 Gr. 50)

HIGHWAY CLASSIFICATION

F.A.P. Rte. 742 - IL. Rte. 2
Functional Class: Other Principal Arterial
ADT: 8,950 (2005) ; 10,350 (2025)
DHV: 1035 (2025)
Design Speed:
55 m.p.h. (Sta. 643+30 to 1053+97.44)
Posted Speed:
55 m.p.h. (Sta. 643+30 to 1053+97.44)

TOTAL BILL OF MATERIALS

DESCRIPTION	UNIT	QTY.
Structure Excavation	Cu. Yd.	327.2
Pipe Underdrains for Structures 4"	Foot	205
Concrete Gutter, Type A (Modified)	Foot	173.2
Furnishing Soldier Piles (W Section)	Foot	1377
Geocomposite Wall Drain	Sq. Yd.	185
Drilling & Setting Soldier Piles (In Soil)	Cu. Ft.	7000
Retaining Wall (Special)	Sq. Ft.	2040
Staining Concrete Structures	Sq. Yd.	181

GENERAL NOTES

All exposed corners 90° or sharper shall be filleted with a 3/4" dressed and beveled strip.

Reinforcement Bars shall conform to the requirements of ASTM A706 Gr 60.

Reinforcement bars designated (E) shall be epoxy coated.

Drilling and setting of piles will require drilling into dense sand and weakly cemented sandstone. (See boring logs). Temporary drill casings or drilling slurry may be required to keep holes open prior to placement of concrete. See drilled soldier pile retaining wall special provision. All drilling will be paid as "Drilling & Setting Soldier Piles (In Soil)".

Concrete shall be painted in accordance with special provisions. The color shall be selected by the engineer.

Exposed steel wide flange/pile shall be painted with an inorganic zinc rich primer/acrylic/acrylic paint system for shop and field painting except for portions located more than 4 feet below the finished grade at the front face of the wall. The finished coat shall be only applied to the exposed surfaces of the steel piles after the concrete panels have been installed. The color of the final finish coat shall be approved by the Resident Engineer and Project Engineer. See special provisions for Cleaning and Painting New Metal Structures.

After placement of bottom precast panel, fill must be placed equally on both sides in order to continue construction of wall and place additional panels. Backfill at front face of wall must be at finished grade.

GENERAL NOTES & TOTAL BILL OF MATERIALS

IL. RTE. 2

RETAINING WALL C

STA. 673+17.00 TO STA. 675+22.00

DESIGNED	CTH
CHECKED	DSG
DRAWN	EBS
CHECKED	DFM

 Howard R. Green Company

SHEET NO. 2	F.A.P. RTE.	SECTION	COUNTY	TOTAL SHEETS	SHEET NO.
9 SHEETS	742	37 R-3	OGLE	345	174
		SN 071-7001	CONTRACT NO. 84788		
FED. ROAD DIST. NO. 7 ILLINOIS FED. AID PROJECT					

STATE OF ILLINOIS
DEPARTMENT OF TRANSPORTATION

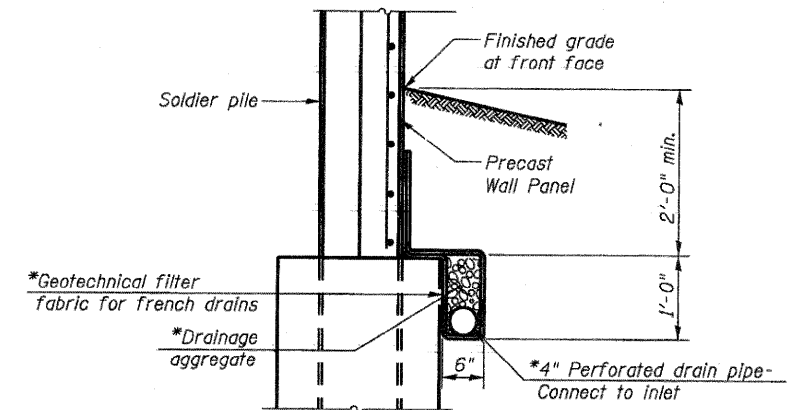
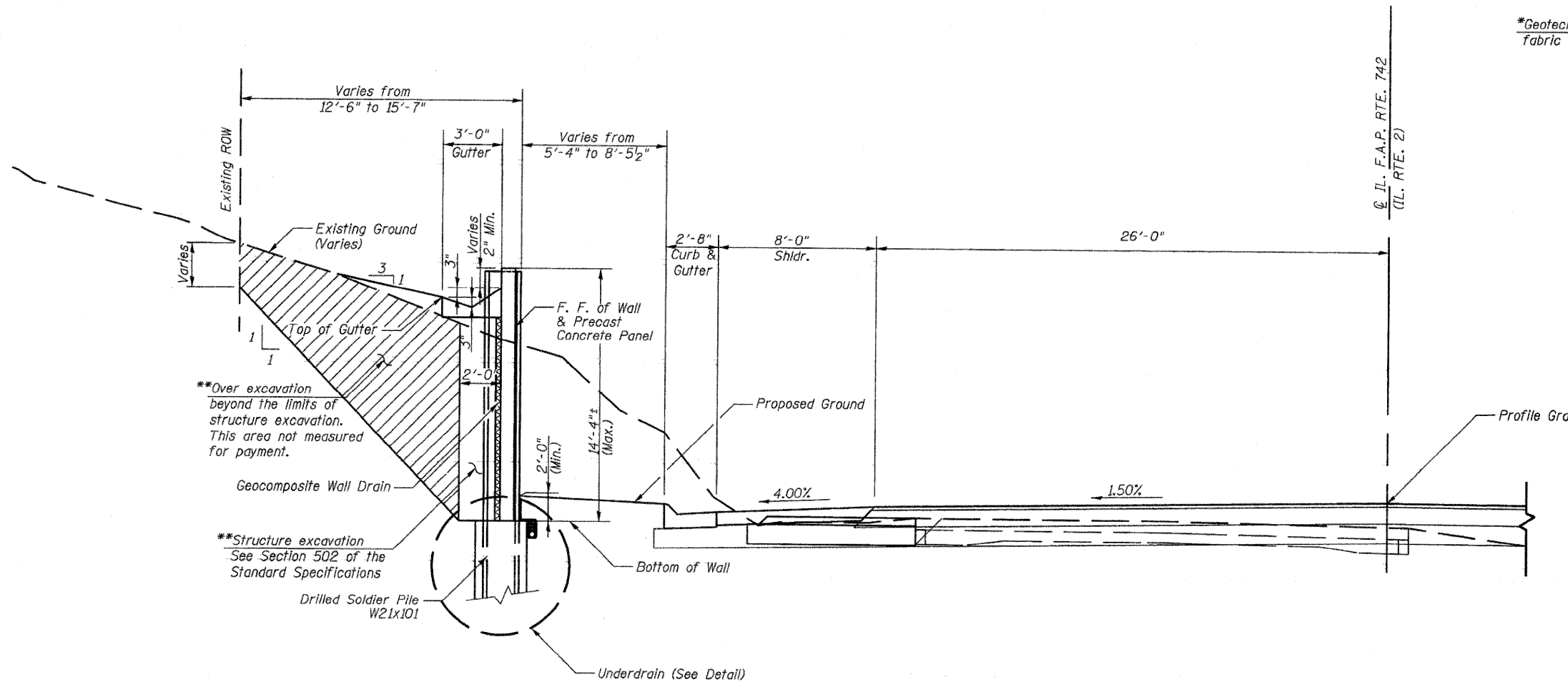

**UNDERDRAIN DETAIL
AT SOLDIER PILES**

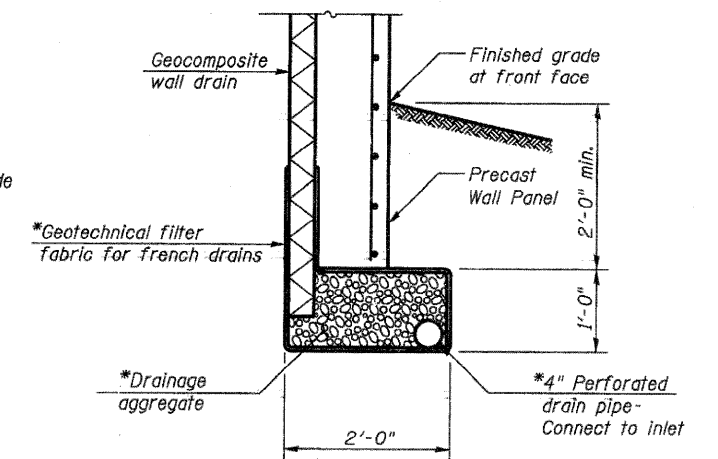

**UNDERDRAIN DETAIL
BETWEEN SOLDIER PILES**

- * Included in the cost of pipe underdrains for structures.
- ** Backfill remainder of structure excavation and over excavation with same material specified for roadway embankment.

**RETAINING WALL TYPICAL SECTION
STA. 673+17.00 TO STA. 675+22.00
(LOOKING NORTH)**

Note:
See Sheet 4 of 9 for W21x101 location and spacing.
Precast panels will be finished with a uniform Ashlar Stone pattern with a horizontal break every 1'-0" vertically. See sheet 5 of 9.

**WALL SECTION
IL. RTE. 2
RETAINING WALL C
STA. 673+17.00 TO STA. 675+22.00**

DESIGNED	DFM
CHECKED	DSG
DRAWN	DSG
CHECKED	DFM

Howard R. Green Company

SHEET NO. 3 9 SHEETS	F.A.P. RTE.	SECTION	COUNTY	TOTAL SHEETS	SHEET NO.
	742	37 R-3	OGLE	345	175
SN 071-7001			CONTRACT NO. 84788		
FED. ROAD DIST. NO. 7 ILLINOIS FED. AID PROJECT					

STATE OF ILLINOIS
DEPARTMENT OF TRANSPORTATION

PANEL SIZE TABLE

PANEL	NOMINAL SIZE	NO.	SF PANELS
A	2 x 10	8	160
B	1.5 x 10 (sloped)	2	30
C	3 x 10	2	60
D	3 x 5	94	1410
E	2 x 5	26	260
F	1.5 x 5 (sloped)	6	45
G	1.5 x 5 (sloped)	4	30
H	3 x 5 (sloped)	3	45
Total		145	2040

For actual Panel sizes, Reinforcement, and Finish see sheet 5 of 9.

See sheet 6 of 9 for drilled pile details.

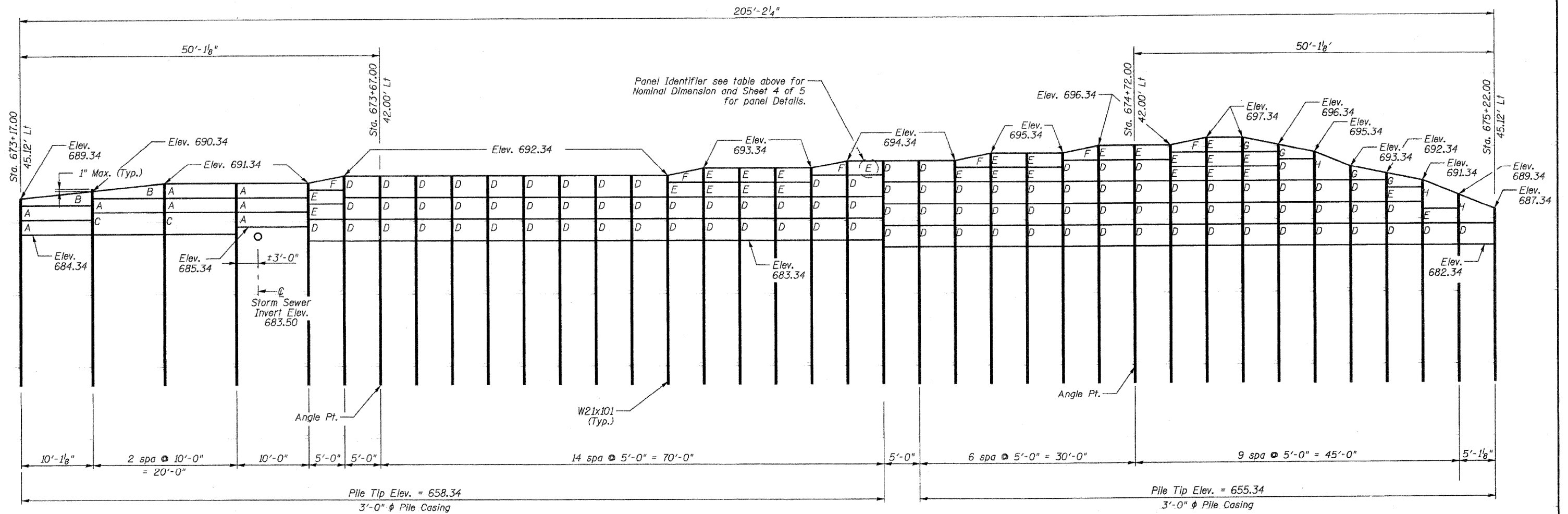

WALL PLAN

**WALL PLAN
IL. RTE. 2
RETAINING WALL C
STA. 673+17.00 TO STA. 675+22.00**

DESIGNED	DFM
CHECKED	DSG
DRAWN	DSG
CHECKED	DFM

Howard R. Green Company

SHEET NO. 4 9 SHEETS	F.A.P. RTE. 742	SECTION 37 R-3	COUNTY OGLE	TOTAL SHEETS 345	SHEET NO. 176
	SN 071-7001		CONTRACT NO. 84788		
FED. ROAD DIST. NO. 7 ILLINOIS FED. AID PROJECT					

STATE OF ILLINOIS
DEPARTMENT OF TRANSPORTATION

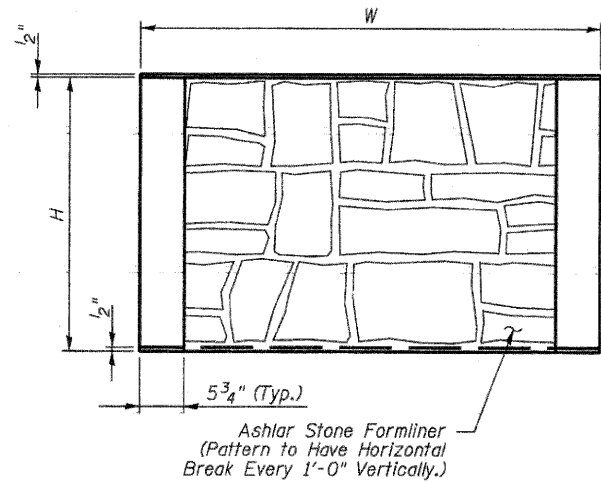

TYPICAL PANEL ELEVATION

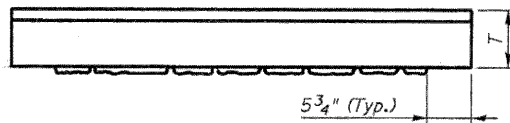

PANEL TOP VIEW

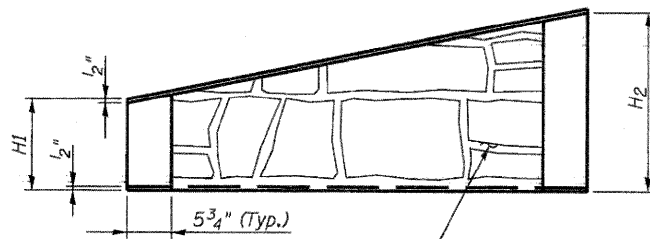

SLOPED PANEL ELEVATION

(Left end low shown.
Right end low opp. hand.)

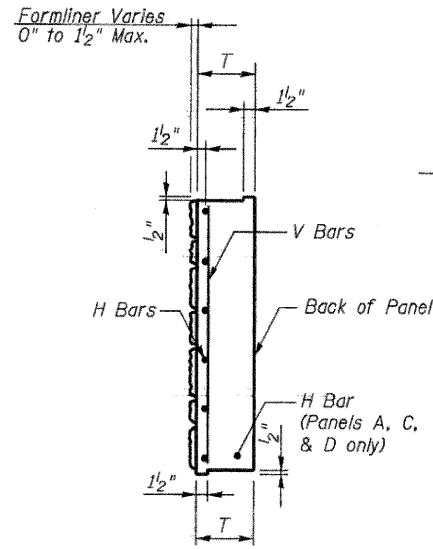

PANEL END VIEW

PANEL DIMENSIONS TABLE

PANEL	H	H1	H2	W	T
A	1'-11 3/4"	-	-	9'-9"	9 1/4"
B	-	11 3/4"	1'-11 3/4"	9'-9"	9 1/4"
C	2'-11 3/4"	-	-	9'-9"	9 1/4"
D	2'-11 3/4"	-	-	4'-9"	7 1/2"
E	1'-11 3/4"	-	-	4'-9"	7 1/2"
F	-	11 3/4"	1'-11 3/4"	4'-9"	7 1/2"
G	-	1'-11 3/4"	11 3/4"	4'-9"	7 1/2"
H	-	3'-11 3/4"	1'-11 3/4"	4'-9"	7 1/2"

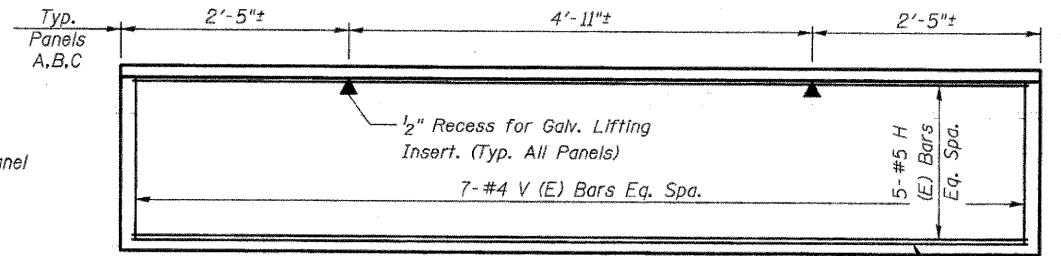

PANEL A REINFORCEMENT

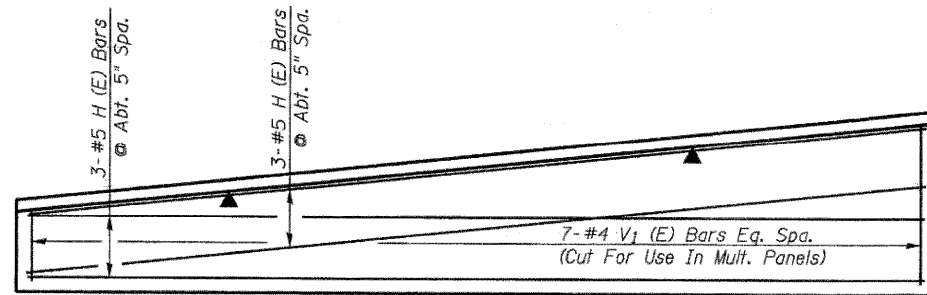

PANEL B REINFORCEMENT

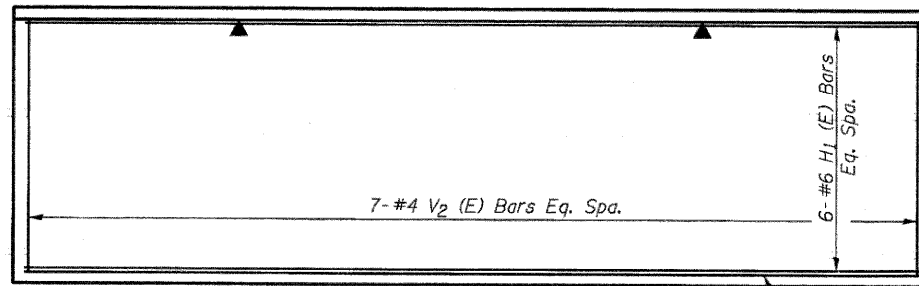

PANEL C REINFORCEMENT

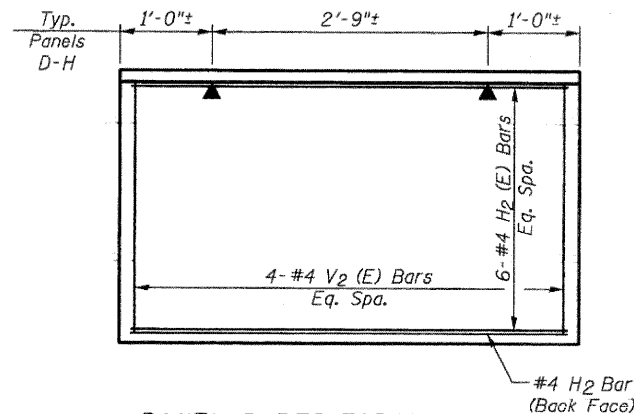

PANEL D REINFORCEMENT

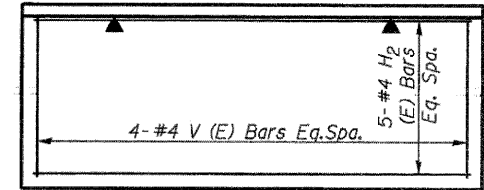

PANEL E REINFORCEMENT

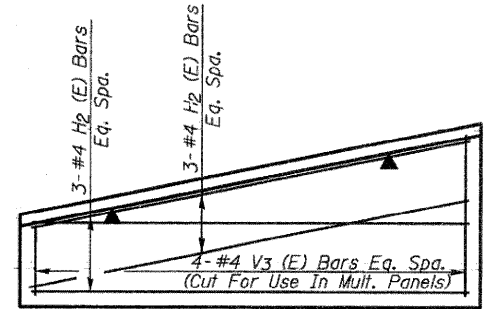

PANEL F REINFORCEMENT

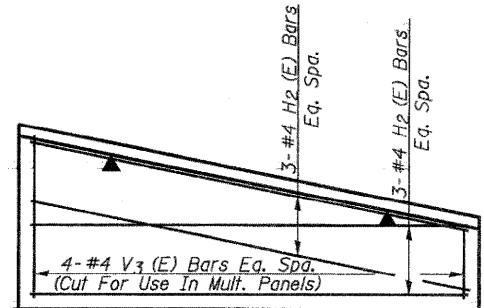

PANEL G REINFORCEMENT

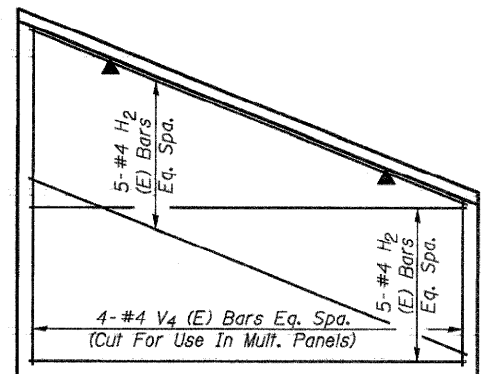

PANEL H REINFORCEMENT

PANEL DETAILS
IL. RTE. 2
RETAINING WALL C
STA. 673+17.00 TO STA. 675+22.00

DESIGNED	DFM
CHECKED	DSG
DRAWN	DSG
CHECKED	DFM

Howard R. Green Company

SHEET NO. 5 9 SHEETS	F.A.P. RTE. 742	SECTION 37 R-3	COUNTY OGLE	TOTAL SHEETS 345	SHEET NO. 177
	SN 071-7001		CONTRACT NO. 84788		
FED. ROAD DIST. NO. 7 ILLINOIS FED. AID PROJECT					

STATE OF ILLINOIS
DEPARTMENT OF TRANSPORTATION

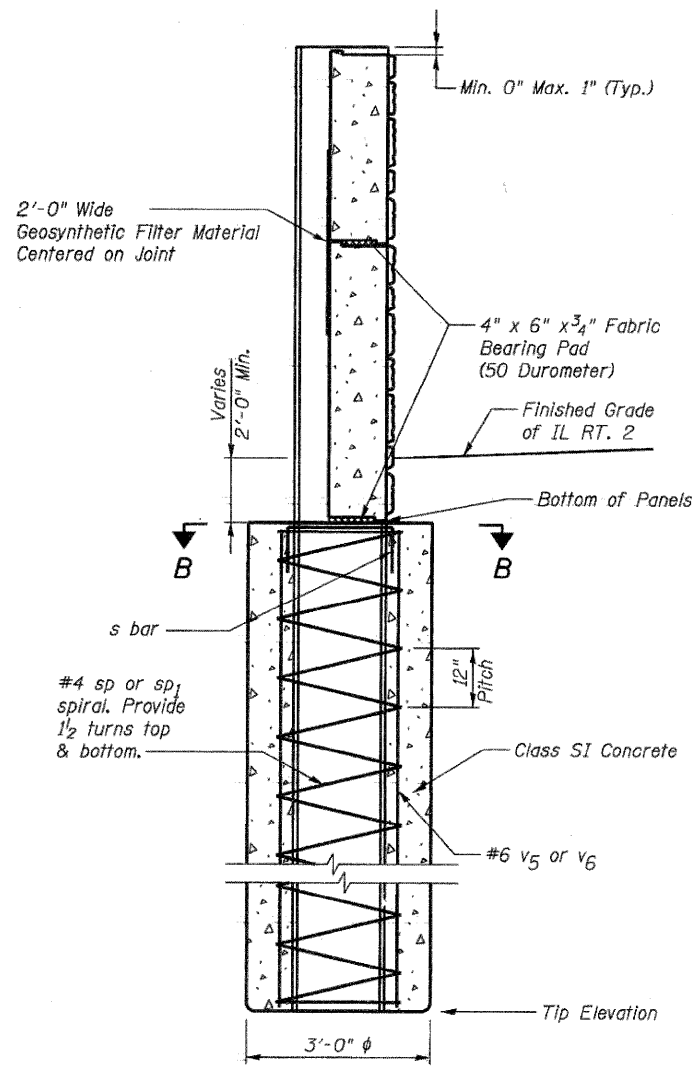

SECTION THROUGH PILE

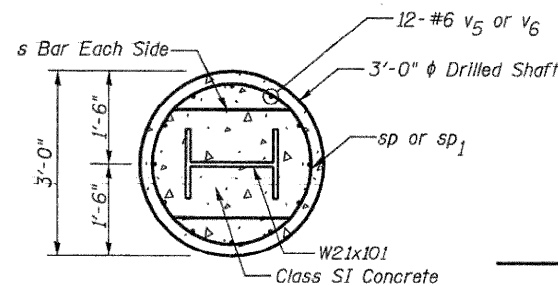

SECTION B-B

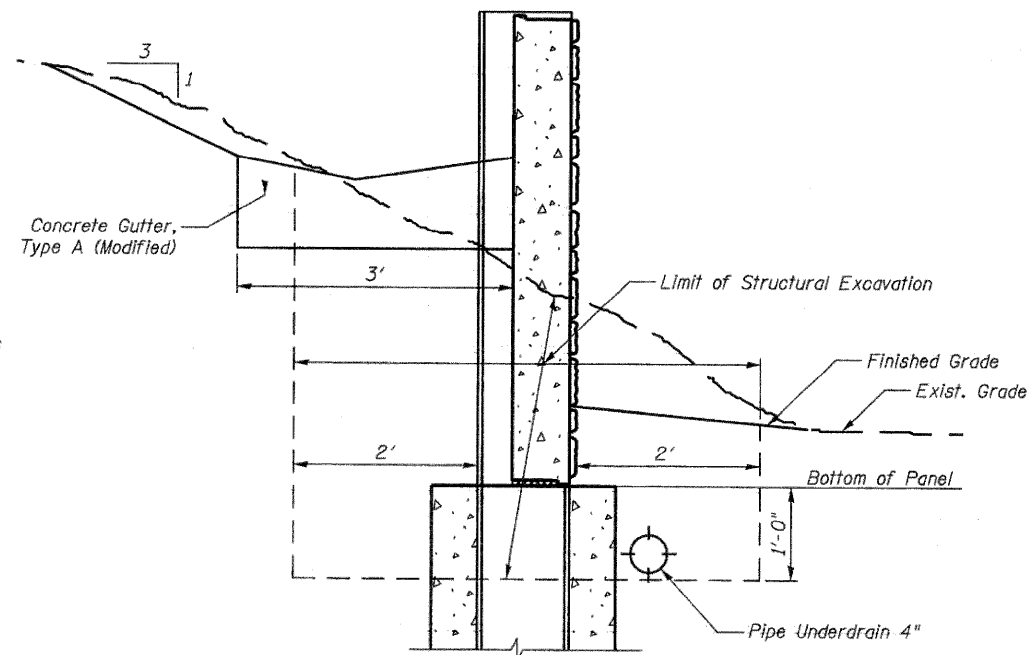

LIMIT OF STRUCTURAL EXCAVATION

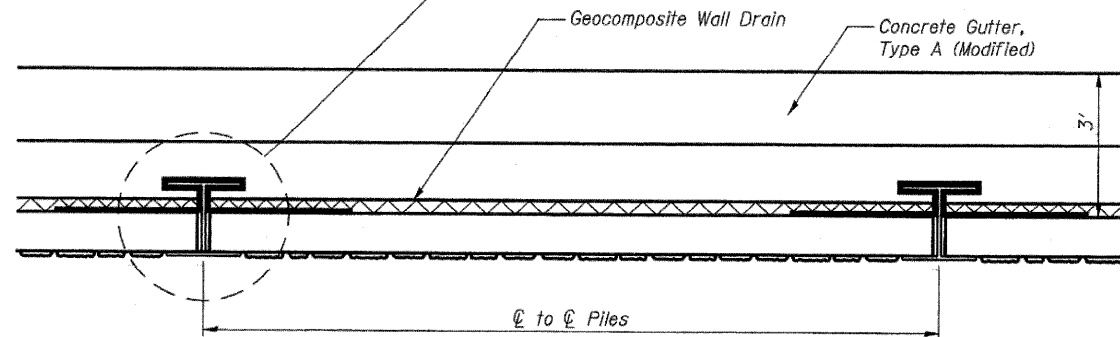
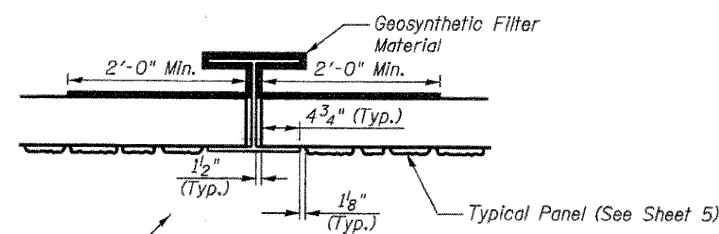

PLAN

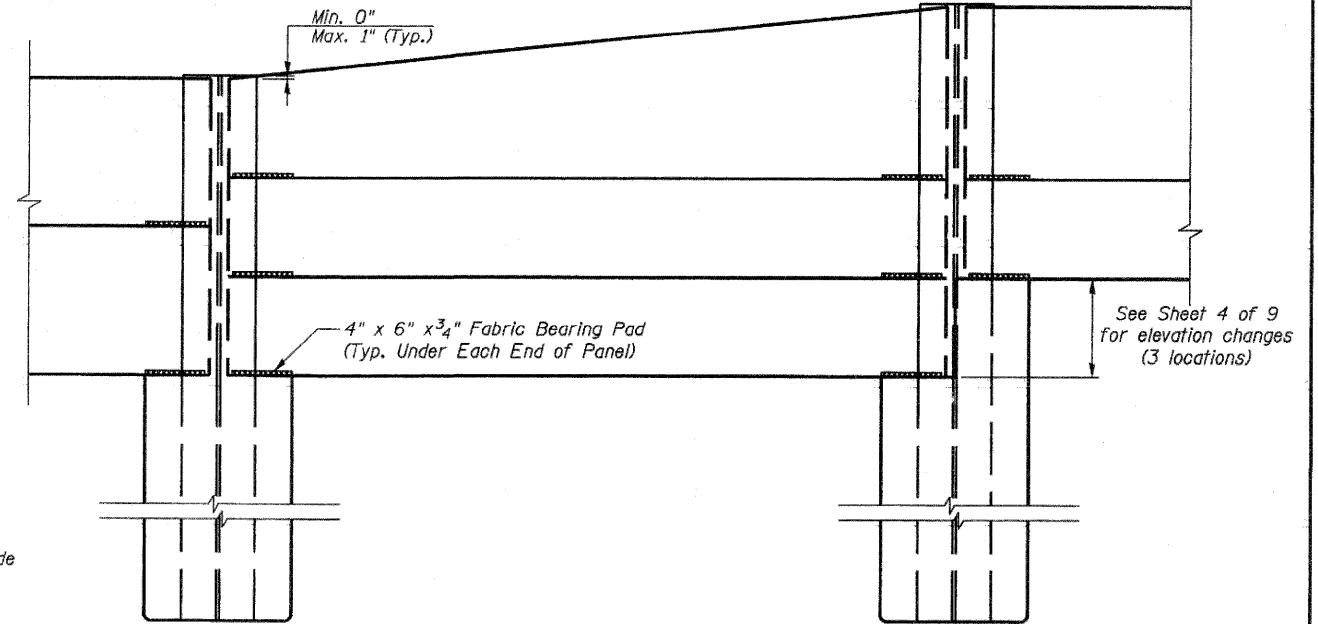

ELEVATION

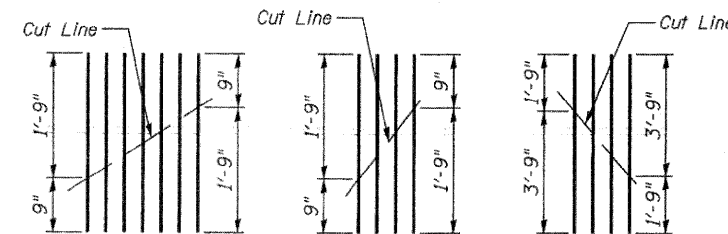

V1 (E) BARS

V3 (E) BARS

V4 (E) BARS

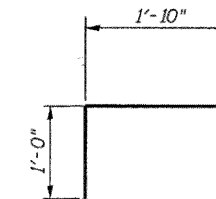

s BARS

Reinforcement Quantities for information only.
Reinforcement & Concrete for panels and pile encasement are included in the pay items "Retaining Wall (Special)" or "Drilling & Setting Soldier Piles".

BILL OF MATERIALS

Bar	No.	Size	Length	Shape
V (E)	160	#4	1'-9"	—
V1(E)	7	#4	2'-6"	—
V2(E)	390	#4	2'-9"	—
V3(E)	20	#4	2'-6"	—
V4(E)	8	#4	5'-6"	—
V5	240	#6	24'-6"	—
V6	216	#6	26'-6"	—
H (E)	62	#5	9'-6"	—
H1(E)	12	#6	9'-6"	—
H2(E)	878	#4	4'-6"	—
** sp	20	#4	24'-6"	⌘
** sp1	18	#4	26'-6"	⌘
s	76	#4	3'-8"	⌘
Reinforcement Bars, Epoxy Coated	Pounds		4020	
Reinforcement Bars	Pounds		24,070	
Concrete Structures	Cu. Yd.		48.6	
Drilling & Setting Soldier Piles	Cu. Ft.		7000	

**Length is height for spiral.

WALL DETAILS

IL. RTE. 2

RETAINING WALL C

STA. 673+17.00 TO STA. 675+22.00

DESIGNED	DFM
CHECKED	DSG
DRAWN	DSG
CHECKED	DFM

Howard R. Green Company

SHEET NO. 6	F.A.P. RTE.	SECTION	COUNTY	TOTAL SHEETS	SHEET NO.
	742	37 R-3	OGLE	345	178
9 SHEETS	SN 071-7001		CONTRACT NO. 84788		
FED. ROAD DIST. NO. 7		ILLINOIS	FED. AID PROJECT		

STATE OF ILLINOIS
DEPARTMENT OF TRANSPORTATION



Illinois Department of Transportation
Division of Highways
Illinois Department of Transportation 0-2

SOIL BORING LOG

Page 1 of 1

Date 3/5/08

ROUTE FA 742 DESCRIPTION P92-064-86 IL 2 retaining wall, just south of Stronghold Entrance LOGGED BY W. Garza

SECTION 37 RS-3 LOCATION Rockvale Twp. 33 NE, SEC. , TWP. 24N, RNG. 10E

COUNTY Ogle DRILLING METHOD Hollow Stem Auger HAMMER TYPE CME-45 Automatic

STRUCT. NO. Station	BORING NO. Station	D E P T H	B L O W S	U C S	M O I S T	Surface Water Elev. ft	Stream Bed Elev. ft	Groundwater Elev.: First Encounter Upon Completion After Hrs.	D E P T H	B L O W S	U C S	M O I S T	Description	Elev. ft
	B-1a 675+12							671.4					VERY DENSE rust St. Peter SANDSTONE Hard Drilling (continued)	662.40
	Offset 12.00 ft LL Ground Surface Elev. 683.40													
				0.8 P	15.0									
				0.8 P	23.0									
				0.8 B	25.0									
				0.2 P	29.0									
				0.0 P	34.0									
				3	16.0									
				33										
				100/3.5										
				100/11										

The Unconfined Compressive Strength (UCS) Failure Mode is indicated by (B-Bulge, S-Shear, P-Penetrometer)
The SPT (N value) is the sum of the last two blow values in each sampling zone (AASHTO T206)
BBS, from 137 (Rev. 8-99)



Illinois Department of Transportation
Division of Highways
Illinois Department of Transportation 0-2

SOIL BORING LOG

Page 1 of 1

Date 3/5/08

ROUTE FA 742 DESCRIPTION P92-064-86 IL 2 retaining wall, south of Stronghold Entrance LOGGED BY Be. Wetzell

SECTION 37 RS-3 LOCATION Rockvale Twp. 33 NE, SEC. , TWP. 24N, RNG. 10E

COUNTY Ogle DRILLING METHOD Hollow Stem Auger HAMMER TYPE B-53 Diedrich Automatic

STRUCT. NO. Station	BORING NO. Station	D E P T H	B L O W S	U C S	M O I S T	Surface Water Elev. ft	Stream Bed Elev. ft	Groundwater Elev.: First Encounter Upon Completion After Hrs.	D E P T H	B L O W S	U C S	M O I S T	Description	Elev. ft
	B-2a 674+02							670.5					STIFF brown SILTY LOAM	664.00
	Offset 11.00 ft LL Ground Surface Elev. 685.50													
				0.7 P	24.0									
				4	3									
				4	6									
				1	3									
				3	3									
				1	1									
				1	2									
				0	1									
				2	4									
				4	6									
				2	4									
				4	6									
				1	3									
				3	8									

The Unconfined Compressive Strength (UCS) Failure Mode is indicated by (B-Bulge, S-Shear, P-Penetrometer)
The SPT (N value) is the sum of the last two blow values in each sampling zone (AASHTO T206)
BBS, from 137 (Rev. 8-99)

BORING LOGS

IL. RTE. 2

RETAINING WALL C

STA. 673+17.00 TO STA. 675+22.00

DESIGNED	DFM
CHECKED	DSG
DRAWN	DSG
CHECKED	DFM

Howard R. Green Company

SHEET NO. 7	F.A.P. RTE.	SECTION	COUNTY	TOTAL SHEETS	SHEET NO.
	742	37 R-3	OGLE	345	179
9 SHEETS	SN 071-7001		CONTRACT NO. 84788		
FED. ROAD DIST. NO. 7		ILLINOIS	FED. AID PROJECT		

STATE OF ILLINOIS
DEPARTMENT OF TRANSPORTATION



Illinois Department of Transportation
Division of Highways
Illinois Department of Transportation/D-2

SOIL BORING LOG

Page 1 of 1

Date 3/5/08

ROUTE FA 742 DESCRIPTION P92-064-06 IL 2 retaining wall, south of Stronghold Entrance LOGGED BY W. Garza
SECTION 37 RS-3 LOCATION Rockvale Twp. - 33 NE, SEC. , TWP. 24N, RNG. 10E
COUNTY Ogle DRILLING METHOD Hollow Stem Auger HAMMER TYPE CME-45 Automatic

STRUCT. NO. Station	DEPTH ft	BULGE ft	UCS tsf	MOISTURE %	DESCRIPTION	DEPTH ft	BULGE ft	UCS tsf	MOISTURE %
					Surface Water Elev. _____ ft				
					Stream Bed Elev. _____ ft				
BORING NO. B-3g Station 673+40 Offset 11:00R LLGL Ground Surface Elev. 686.40					Groundwater Elev.: First Encounter 669.4 ft Upon Completion 668.4 ft After _____ Hrs.				
Asphalt Concrete					VERY DENSE rusty yellow fine SAND (continued) 665.40				
	884.40				End of Boring				
VERY STIFF brown SILTY CLAY LOAM	5		2.7	22.0					
	882.90								
MEDIUM brown SILTY CLAY LOAM	3		0.6	26.0					
	880.40								
VERY SOFT brown SILTY CLAY LOAM with bottom 6" fine SAND	1		0.2	24.0					
	877.40								
VERY DENSE rust fine SAND	16								
	875.40								
VERY DENSE rusty yellow fine SAND	21								
	872.90								
Augers easily	27								
VERY DENSE rusty yellow fine SAND	100/7								
	870.40								
VERY DENSE off white fine SAND	100/2								
	867.90								
	100/4								

The Unconfined Compressive Strength (UCS) Failure Mode is indicated by (B-Bulge, S-Shear, P-Penetrometer)
The SPT (N value) is the sum of the last two blow values in each sampling zone (AASHTO T206)
BBS, from 137 (Rev. 8-99)



Illinois Department of Transportation
Division of Highways
Illinois Department of Transportation/D-2

SOIL BORING LOG

Page 1 of 1

Date 3/5/08

ROUTE FA 742 DESCRIPTION P92-064-06 IL 2 retaining wall, south of Stronghold Entrance LOGGED BY Be. Wetzel
SECTION 37 RS-3 LOCATION Rockvale Twp. - 33 NE, SEC. , TWP. 24N, RNG. 10E
COUNTY Ogle DRILLING METHOD Hollow Stem Auger HAMMER TYPE B-53 Diedrich Automatic

STRUCT. NO. Station	DEPTH ft	BULGE ft	UCS tsf	MOISTURE %	DESCRIPTION	DEPTH ft	BULGE ft	UCS tsf	MOISTURE %
					Surface Water Elev. _____ ft				
					Stream Bed Elev. _____ ft				
BORING NO. B-4a Station 672+75 Offset _____ Ground Surface Elev. 687.00					Groundwater Elev.: First Encounter _____ ft Upon Completion _____ ft After _____ Hrs.				
MEDIUM brown SILTY CLAY			1.0	20.0	Wash				
					SOFT brown SILTY LOAM with SAND lenses 685.50				
	684.50				End of Boring				
MEDIUM brown SILTY CLAY	3		0.6	28.0					
	683.00								
MEDIUM brown SILTY CLAY	1		0.6	31.0					
	680.50								
SOFT brown SILTY CLAY LOAM	0		0.4	21.0					
	677.50								
LOOSE brown fine SAND	1								
	675.50								
MEDIUM tan fine SAND	3								
	673.00								
MEDIUM tan fine SAND	3								
	670.00								
MEDIUM brown SILTY LOAM	3		0.6	23.0					
	668.00								
	100/4								

The Unconfined Compressive Strength (UCS) Failure Mode is indicated by (B-Bulge, S-Shear, P-Penetrometer)
The SPT (N value) is the sum of the last two blow values in each sampling zone (AASHTO T206)
BBS, from 137 (Rev. 8-99)

BORING LOGS

IL. RTE. 2

RETAINING WALL C

STA. 673+17.00 TO STA. 675+22.00

DESIGNED	DFM
CHECKED	DSG
DRAWN	DSG
CHECKED	DFM

Howard R. Green Company

SHEET NO. 8	F.A.P. RTE.	SECTION	COUNTY	TOTAL SHEETS	SHEET NO.
	742	37 R-3	OGLE	345	180
9 SHEETS	SN 071-7001		CONTRACT NO. 84788		
	FED. ROAD DIST. NO. 7 ILLINOIS FED. AID PROJECT				

STATE OF ILLINOIS
DEPARTMENT OF TRANSPORTATION



Illinois Department
of Transportation
Division of Highways
Illinois Department of Transportation ID-2

SOIL BORING LOG

Page 1 of 1

Date 3/5/08

ROUTE FA 742 DESCRIPTION P92-064-86 IL 2 retaining wall, south of
Sironchold Entrance LOGGED BY W. Garza
SECTION 37 R8-3 LOCATION Rockvale Twp. - 33 NE. SEC. TWP. 24N. RNG. 10E
COUNTY Ogle DRILLING METHOD Hollow Stem Auger HAMMER TYPE CME-45 Automatic

STRUCT. NO.	D	B	U	M	Surface Water Elev.	D	B	U	M
Station	E	L	C	O	ft	E	L	C	O
	P	O	S	I	Stream Bed Elev.	P	O	S	I
	T	W	Qu	S	Groundwater Elev.:	H	W	Qu	T
BORING NO.	H	S		T	First Encounter	(ft)	(ft)	(tsf)	(%)
Station					Upon Completion	ft			
Offset					After	ft			
Ground Surface Elev.	(ft)	(ft)	(tsf)	(%)	Hrs.	ft	(ft)	(ft)	(%)
SOFT brown LOAM			0.3	15.0	Wash				
			P		VERY DENSE rusty yellow fine	663.60			
					SAND, St. Peter's SANDSTONE				
					(continued)				
MEDIUM brown SILTY CLAY	2				Hard Drilling				
LOAM	3		0.5	26.0					
	4		P			661.10			
SOFT brown SILTY LOAM	1				Wash	100/1"			
	1		0.3	26.0	VERY DENSE rusty yellow fine				
	3		B		SAND	658.60			
					End of Boring				
SOFT brown SILTY LOAM	0								
	1		0.4	26.0					
	2		B						
SOFT brown SILTY LOAM	0								
	1		0.3	26.0					
	2		B						
MEDIUM cream white moist fine	2								
SAND	5								
	21								
VERY DENSE rusty yellow fine	27								
SAND	100/10"								
VERY DENSE rusty yellow fine	100/5"								
SAND	100/1"								

The Unconfined Compressive Strength (UCS) Failure Mode is indicated by (B-Bulge, S-Shear, P-Penetrometer)
The SPT (N value) is the sum of the last two blow values in each sampling zone (AASHTO T208)
BBS, from 137 (Rev. 8-99)

BORING LOGS
IL. RTE. 2
RETAINING WALL C
STA. 673+17.00 TO STA. 675+22.00

DESIGNED	DFM
CHECKED	DSG
DRAWN	DSG
CHECKED	DFM

Howard R. Green Company

SHEET NO. 9	F.A.P. RTE.	SECTION	COUNTY	TOTAL SHEETS	SHEET NO.
9 SHEETS	742	37 R-3	OGLE	345	181
		SN 071-7001	CONTRACT NO. 84788		
FED. ROAD DIST. NO. 7 ILLINOIS FED. AID PROJECT					

Benchmark:
Existing Structure: Built in 1952 as a Single Barrel 4'-0" X 4'-0" R.C. Box Culvert, with a Culvert Length of +31'-5". Traffic to be Maintained Utilizing Stage Construction. No Salvage.

STATE OF ILLINOIS
DEPARTMENT OF TRANSPORTATION

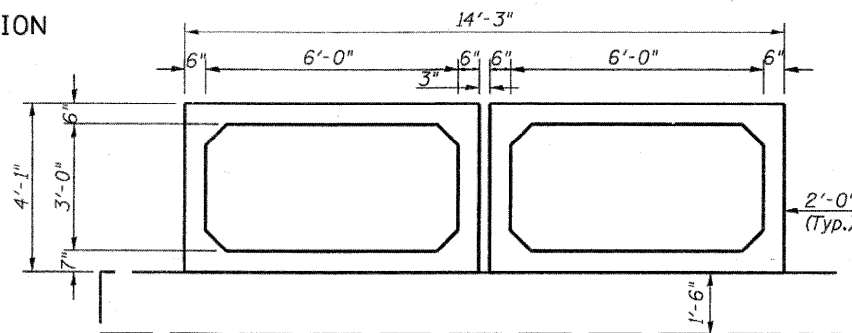
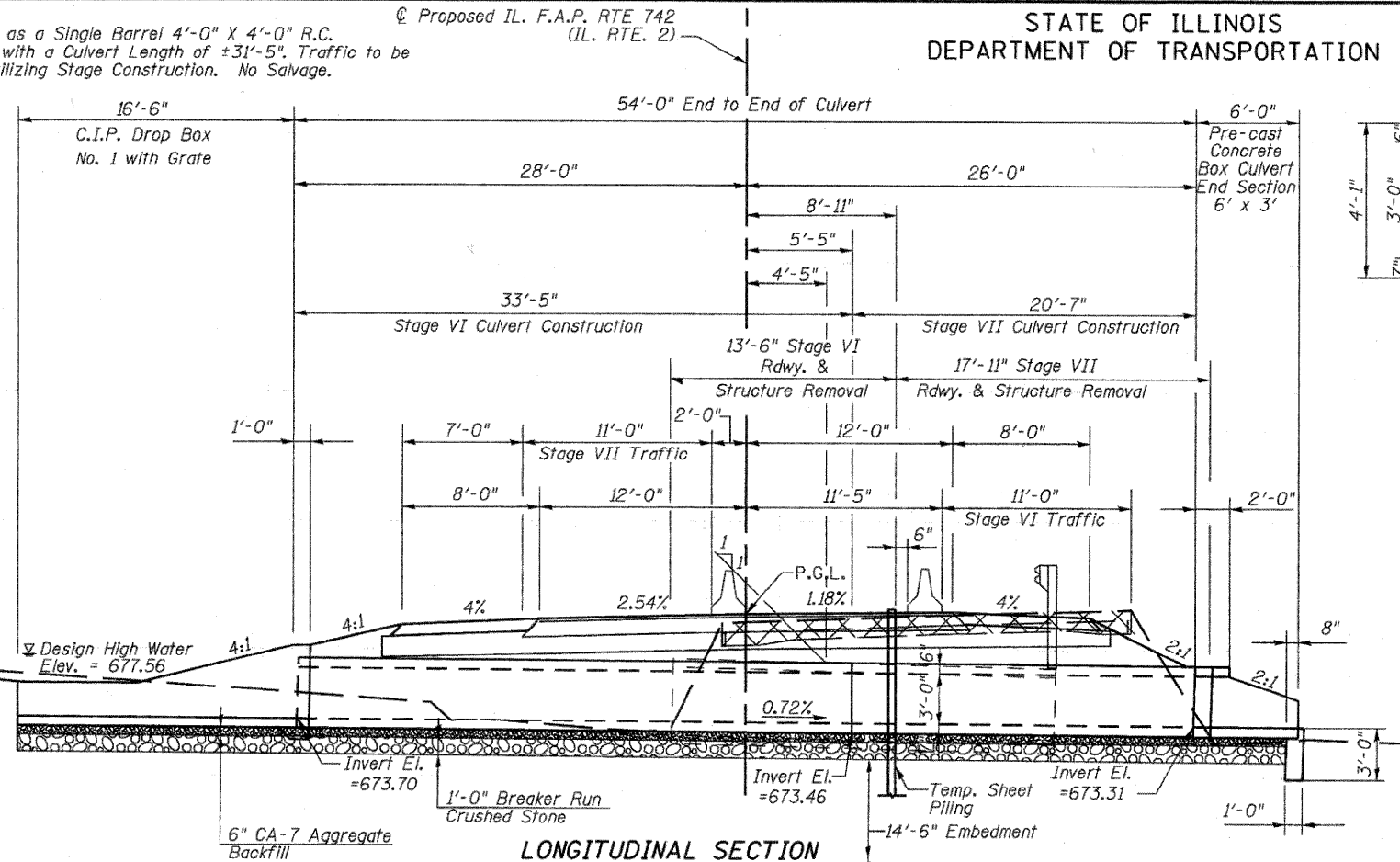

SHEET INDEX

NO.	DESCRIPTION
1	GENERAL PLAN & ELEVATION
2	BORING LOG

DESIGN STRESSES

$f_y = 60,000$ psi
 $f_y = 65,000$ psi (Welded Wire Fabric)
 $f'_c = 3,500$ psi
 $f'_c = 5,000$ psi (Precast)

DESIGN SPECIFICATIONS

2002 A.A.S.H.T.O. Specifications & Supplements

LOADING HS 20-44

Allow 50#/Sq. Ft. for future wearing surface

GENERAL NOTES

Precast Box shall conform to the requirements of A.A.S.H.T.O. M273 (A.S.T.M. C850). The maximum design fill height for this structure is 4'-0".

Culvert Concrete thickness shown shall be considered the minimum acceptable. Other thickness will be allowed if approved by the engineer.

Breaker-Run Crushed Stone to be placed as a subbase. Min. depth is 1'-0".

Work this sheet with Staging sheets.

TOTAL BILL OF MATERIALS

DESCRIPTION	UNIT	QTY.
Removal of Existing Structures No. 1	Each	1
Precast Concrete Box Culvert 6' X 3'	Foot	108
Breaker-Run Crushed Stone	Ton	96
Temporary Sheet Piling*	Sq. Ft.	578.4
Precast Concrete Box Culvert End Section, 6' x 3'	Each	2
Drop Box, No. 1	Each	1

*See sheet piling design on staging culvert typical section sheet.

HORIZONTAL CURVE DATA

PI STA. = 617+60.09
 $\Delta = 9^\circ 48' 58.6"$ (LT)
 $D = 2^\circ 00' 00"$
 $R = 2,864.79'$
 $T = 246.01'$
 $L = 490.81'$
 $E = 10.54'$
P.C. STA. = 615+14.08
P.T. STA. = 620+04.89
S.E. = 0.0341'

PROFILE GRADE

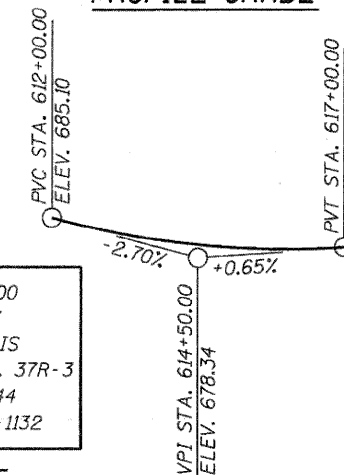

STATION 615+22.00
BUILT 20__ BY
STATE OF ILLINOIS
F.A.P. RTE. 742 SEC. 37R-3
LOADING HS20-44
STRUCTURE NO. 071-1132

NAME PLATE
See Std. 515001

WATERWAY INFORMATION TABLE

	Frequency Year	Discharge (cfs)	Waterway Opening Sq. Ft.		Natural H.W.E.	Head (ft)		Headwater Elev. (ft)	
			Existing	Proposed		Existing	Proposed	Existing	Proposed
Ten-Year Design	10	90	16.0	36.0	5.04	3.67	678.01	677.39	
Base	50	124	16.0	36.0	5.77	3.84	678.74	677.56	
EX OVT	100	145	16.0	36.0	6.34	3.97	679.31	677.69	
PR OVT	176	156	16.0	36.0	6.81		679.78		
Max Calc	500	200		36.0		4.41		678.13	

10-Year Velocity through Existing Structure = 11.6 fps
10-Year Velocity through Proposed Structure = 7.1 fps

GENERAL PLAN & ELEVATION
IL. RTE. 2 OVER
TRIBUTARY TO ROCK RIVER
STA. 615+22.00

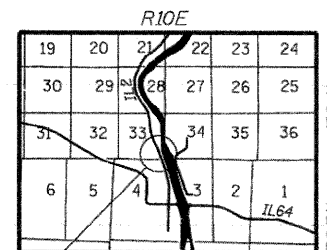
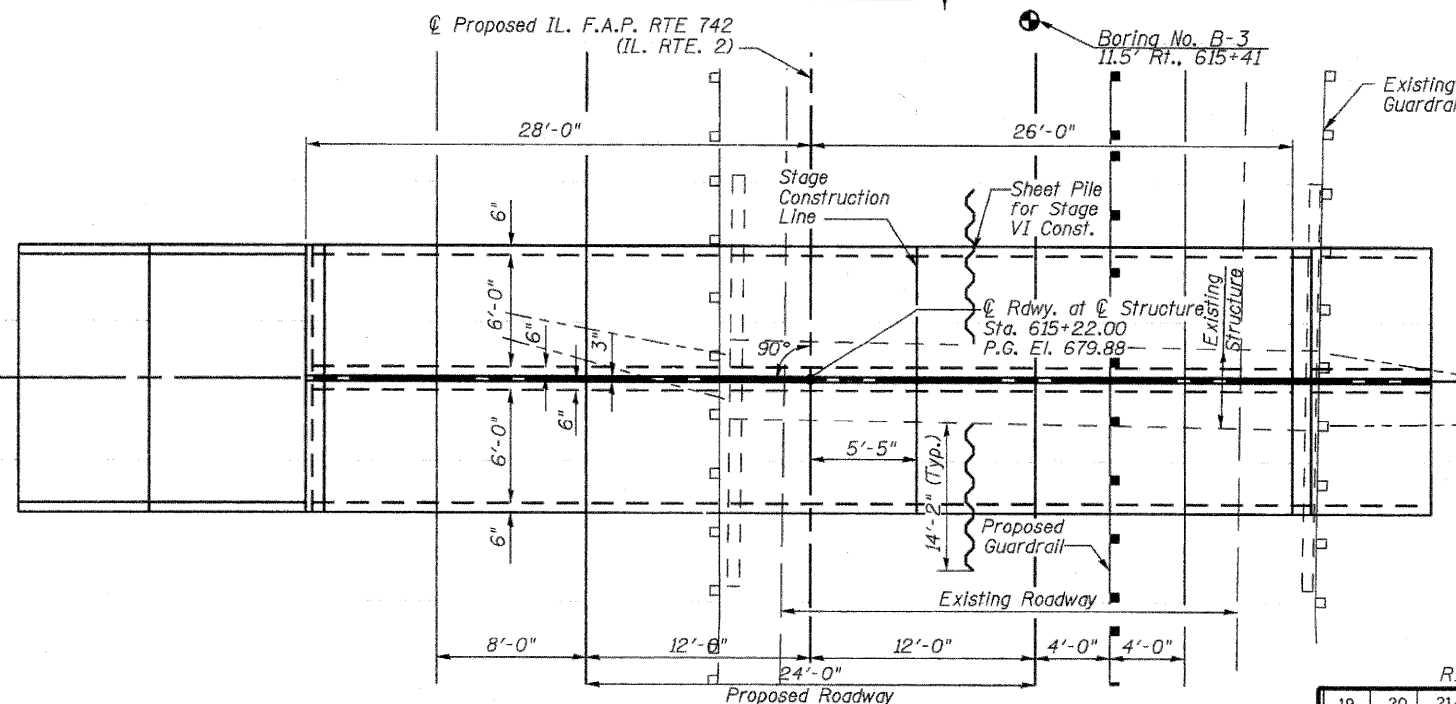

Project Location

DESIGNED CTH
CHECKED DSG
DRAWN EBS
CHECKED DFM

STATE OF ILLINOIS
DAVID F. MAXWELL
081-005455
ST. LOUIS, MO.
REGISTERED STRUCTURAL ENGINEER

David F. Maxwell, S.E. Reg. No. 081-005455
Date: 2/19/09
My registration expires November 30, 2010.

PLAN

Howard R. Green Company

SHEET NO. 1	F.A.P. RTE. 742	SECTION 37 R-3	COUNTY OGLE	TOTAL SHEETS 345	SHEET NO. 182
2 SHEETS		SN 071-1132	CONTRACT NO. 84788		
FED. ROAD DIST. NO. 7 ILLINOIS FED. AID PROJECT					

Benchmark:

Existing Structure: Built in 1952 as a Single Barrel 10'-0" x 7'-0" R. C. Box Culvert, with a Culvert Length of ±32'-0". Traffic to be Maintained Utilizing Stage Construction. No Salvage

STATE OF ILLINOIS
DEPARTMENT OF TRANSPORTATION

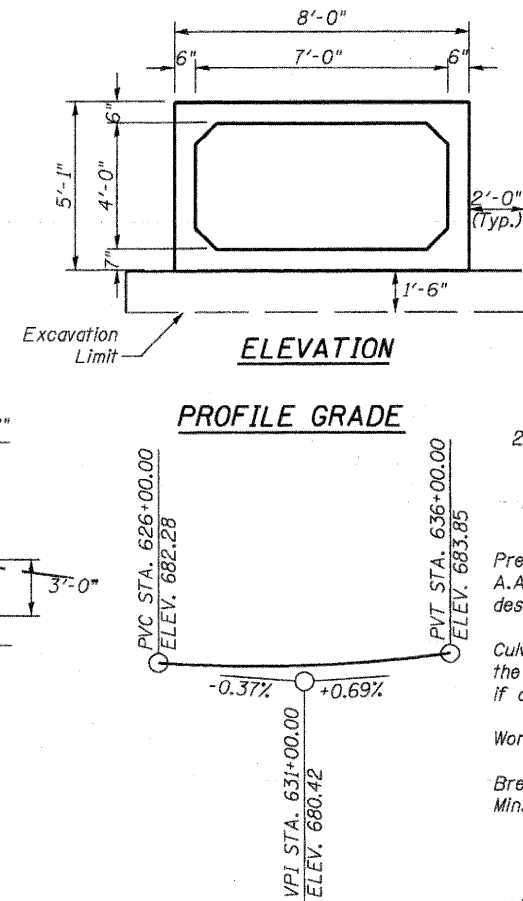
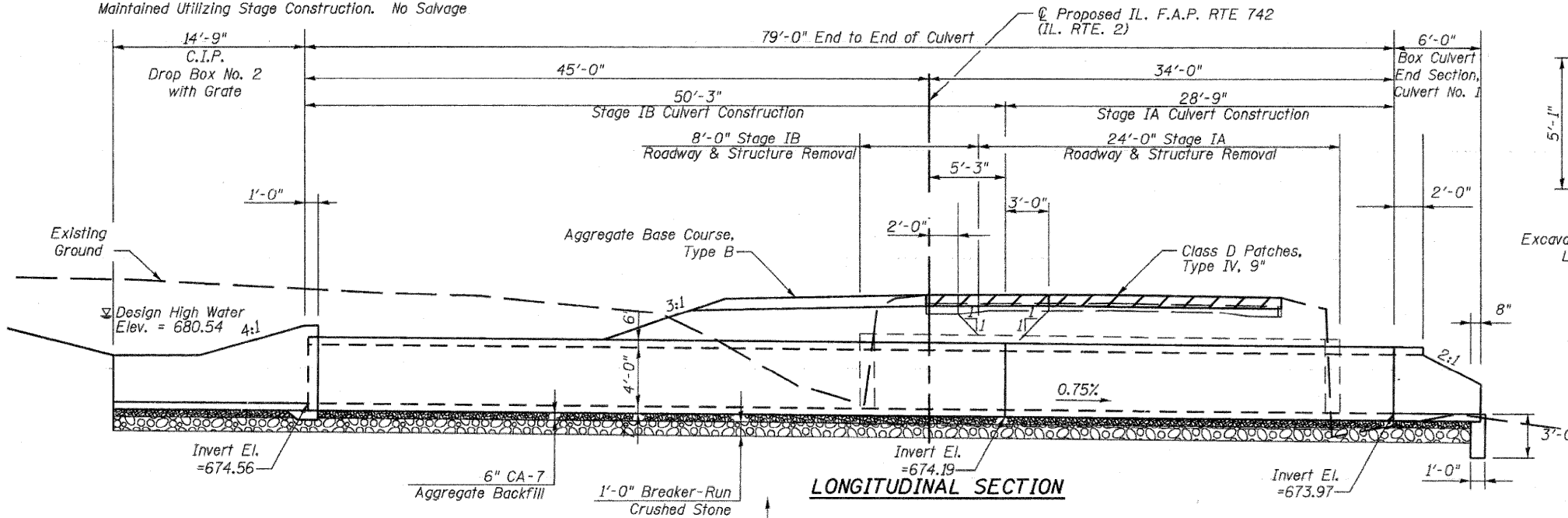

DESIGN STRESSES

$f_y = 60,000$ psi
 $f_y = 65,000$ psi (Welded Wire Fabric)
 $f'_c = 3,500$ psi
 $f'_c = 5,000$ psi (Precast)

DESIGN SPECIFICATIONS

2002 A.A.S.H.T.O. Specifications & Supplements

LOADING HS 20-44

Allow 50#/Sq. Ft. for future wearing surface

GENERAL NOTES

Precast Box shall conform to the requirements of A.A.S.H.T.O. M259 (A.S.T.M. C789). The maximum design fill height for this structure is 4'-0".

Culvert Concrete thickness shown shall be considered the minimum acceptable. Other thickness will be allowed if approved by the engineer.

Work this sheet with Staging sheets.

Breaker-Run Crushed Stone to be placed as a Subbase. Min. depth over competent rock is 1'-0".

TOTAL BILL OF MATERIALS

DESCRIPTION	UNIT	QTY.
Removal of Existing Structures No. 2	Each	1
Drop Box, No. 2	Each	1
Box Culvert End Section, Culvert No. 1	Each	1
Precast Concrete Box Culvert 7' X 4'	Foot	79
Breaker-Run Crushed Stone	Ton	84

STATION 626+61.07
 BUILT 20__ BY
 STATE OF ILLINOIS
 F.A.P. RTE. 742 SEC. 37R-3
 LOADING HS20-44
 STRUCTURE NO. 071-1131

NAME PLATE
 See Std. 515001

WATERWAY INFORMATION TABLE

	Frequency Year	Discharge (cfs)	Waterway Opening Sq. Ft.		Natural H.W.E.	Head (ft)		Headwater Elev. (ft)	
			Existing	Proposed		Existing	Proposed	Existing	Proposed
Drainage Area = 0.22 sq. mi. Existing Low Grade Elevation: 681.63 ft. @ Sta. 627+89 Proposed Low Grade Elevation: 681.63 ft. @ Sta. 629+51									
Ten-Year	10	77	70.0	28.0		3.41	4.57	676.30	679.14
Design	50	189	70.0	28.0		4.06	5.97	676.95	680.54
Base	100	238	70.0	28.0		4.35	7.46	677.24	682.03
EX OVT									
PR OVT	81	226		28.0			7.06		681.63
Max Calc	500	360		28.0		5.62		678.51	

10-Year Velocity through Existing Structure =
 10-Year Velocity through Proposed Structure = 7.1 fps

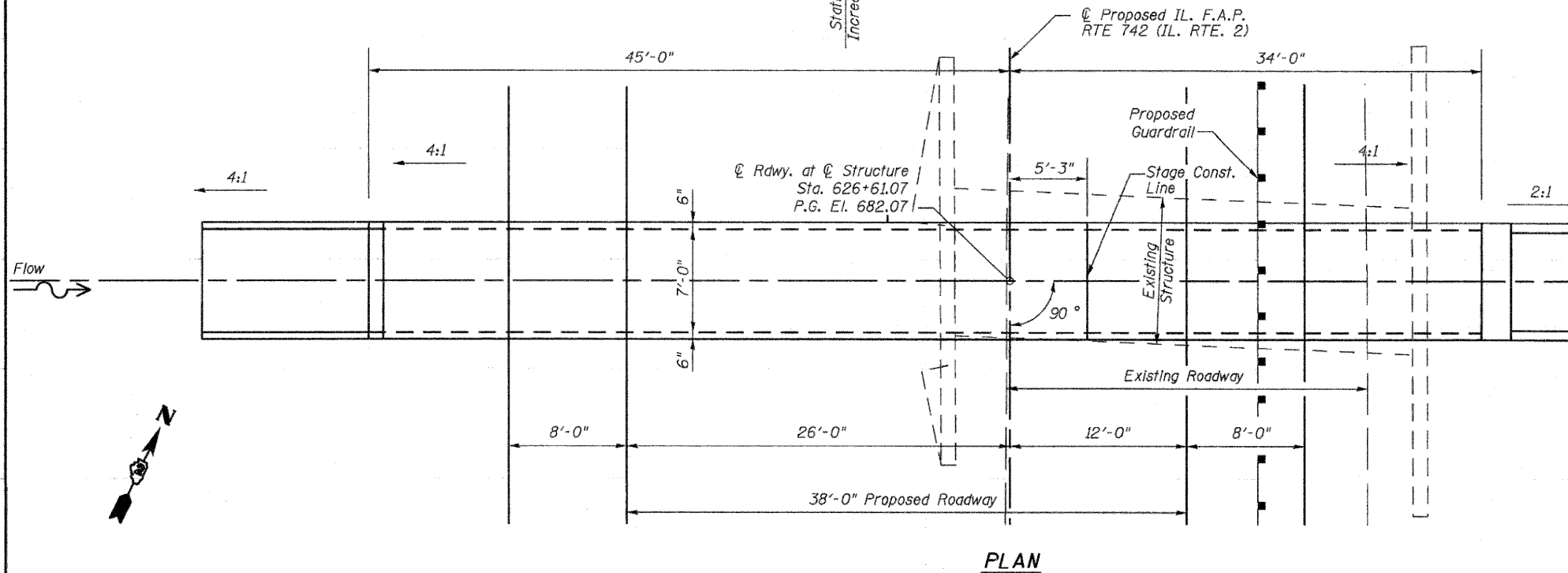

PLAN

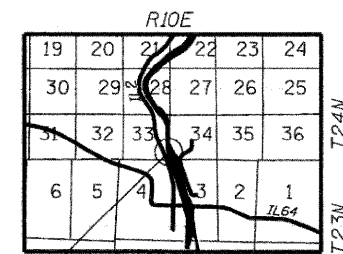

LOCATION SKETCH

**GENERAL PLAN & ELEVATION
 IL. RTE. 2 OVER
 TRIBUTARY TO ROCK RIVER
 STA. 626+61.07**

DESIGNED	CTH
CHECKED	DSG
DRAWN	EBS
CHECKED	DFM

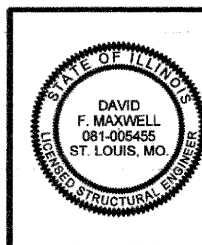

David F. Maxwell, S.E. Reg. No. 081-005455
 Date: 2/19/09
 My registration expires November 30, 2010.

Howard R. Green Company

SHEET NO. 1 1 SHEETS	F.A.P. RTE. 742	SECTION 37 R-3	COUNTY OGLE	TOTAL SHEETS 345	SHEET NO. 184
	SN 071-1131		CONTRACT NO. 84788		
FED. ROAD DIST. NO. 7 ILLINOIS FED. AID PROJECT					

Benchmark:

Existing Structure: Built in 1952 as a single barrel 5'-0" x 4'-0" R.C. Box Culvert with a length of 76'-0". Traffic to be Maintained Utilizing Stage Construction. No Salvage.

STATE OF ILLINOIS
DEPARTMENT OF TRANSPORTATION

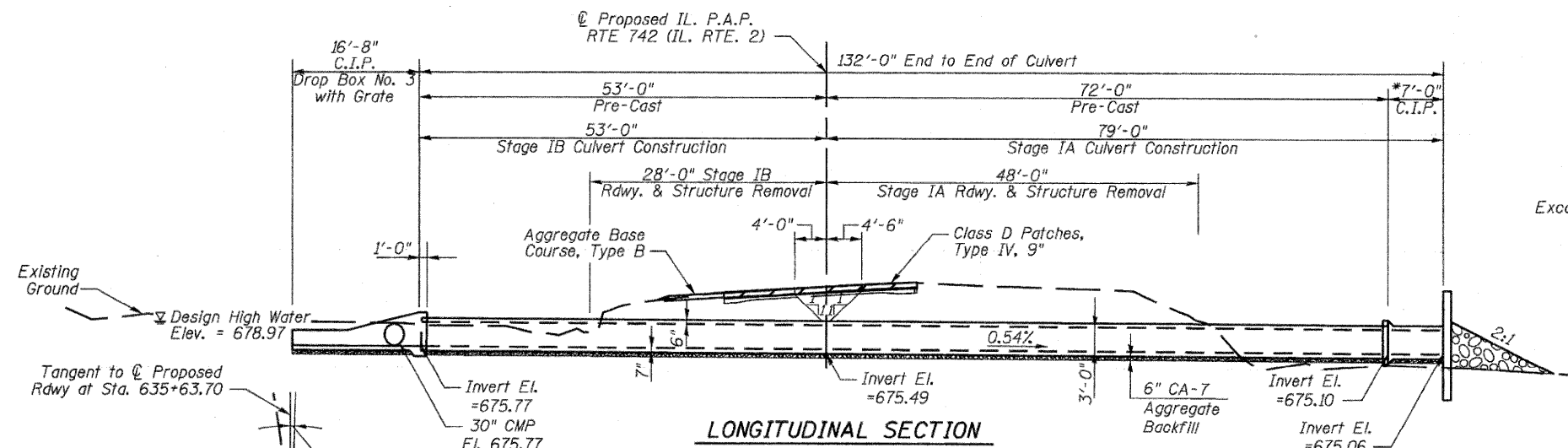

LONGITUDINAL SECTION

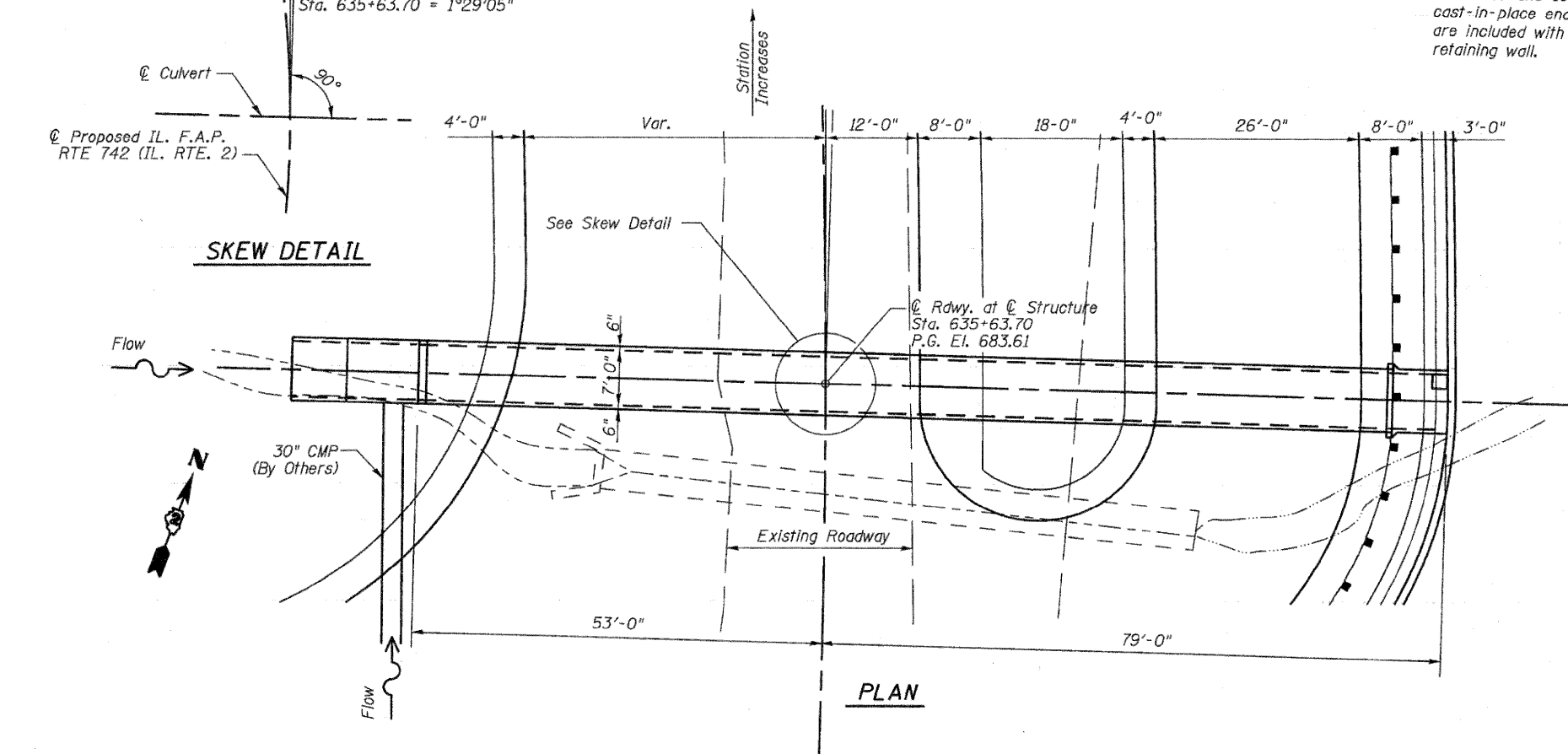

PLAN

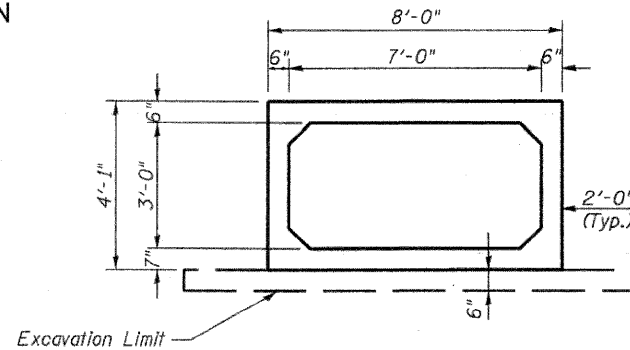

HORIZONTAL CURVE DATA

PI STA. = 638+41.48
 $\Delta = 31^\circ 54' 45.1''$ (LT)
 $D = 4^\circ 00' 00''$
 $R = 1,432.40'$
 $T = 409.56'$
 $L = 797.84'$
 $E = 57.40'$
 P.C. STA. = 634+31.91
 P.T. STA. = 642+29.75
 $S.E. = 0.05081'$

PROFILE GRADE

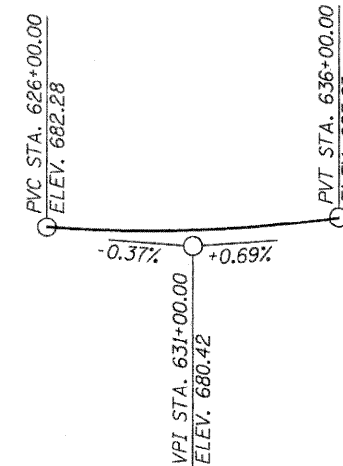

WATERWAY INFORMATION TABLE

	Frequency Year	Discharge (cfs)	Waterway Opening Sq. Ft.		Natural H.W.E.	Head (ft)		Headwater Elev. (ft)	
			Existing	Proposed		Existing	Proposed	Existing	Proposed
Ten-Year	10	49	20.0	21.0		2.86	2.80	678.07	678.58
Design	50	86	20.0	21.0		3.67	3.19	678.88	678.97
Base	100	101	20.0	21.0		4.06	3.33	679.27	679.11
EX OVT									
PR OVT									
Max Calc	500	139		21.0		5.03	3.33	680.24	679.11

10-Year Velocity through Existing Structure = 2.4 fps
 10-Year Velocity through Proposed Structure = 6.0 fps

DESIGN STRESSES

$f_y = 60,000$ psi
 $f_y = 65,000$ psi (Welded Wire Fabric)
 $f'_c = 3,500$ psi
 $f'_c = 5,000$ psi (Precast)

DESIGN SPECIFICATIONS

2002 A.A.S.H.T.O. Specifications & Supplements

LOADING HS 20-44

Allow 50#/Sq. Ft. for future wearing surface

GENERAL NOTES

Precast Box shall conform to the requirements of A.A.S.H.T.O. M259 (A.S.T.M. C789). The maximum design fill height for this structure is 6'-0".

Culvert Concrete thickness shown shall be considered the minimum acceptable. Other thickness will be allowed if approved by the engineer.

Work this sheet with Staging sheets.

STATION 635+63.70
 BUILT 20__ BY
 STATE OF ILLINOIS
 F.A.P. RTE. 742 SEC. 37R-3
 LOADING HS20-44
 STRUCTURE NO. 071-1133

NAME PLATE

See Std. 515001

TOTAL BILL OF MATERIALS

DESCRIPTION	UNIT	QTY.
Removal of Existing Structures No. 3	Each	1
Drop Box, No. 3	Each	1
Precast Concrete Box Culvert 7' X 3' Special	Foot	125

DESIGNED	CTH
CHECKED	DSG
DRAWN	EBS
CHECKED	DFM

STATE OF ILLINOIS
 DAVID F. MAXWELL
 081-005455
 ST. LOUIS, MO
 LICENSED STRUCTURAL ENGINEER

David F. Maxwell, S.E. Reg. No. 081-005455
 Date: 2/19/09
 My registration expires November 30, 2010.

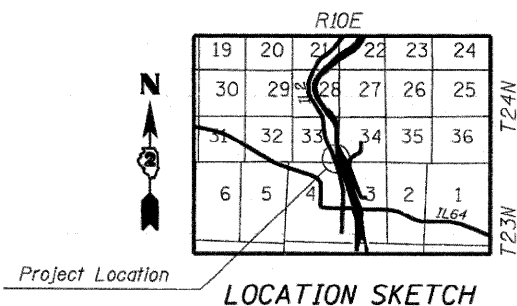

Howard R. Green Company

SHEET NO. 1 1 SHEETS	F.A.P. RTE.	SECTION	COUNTY	TOTAL SHEETS	SHEET NO.
	742	37 R-3	OGLE	345	185
SN 071-1133			CONTRACT NO. 84788		
FED. ROAD DIST. NO. 7 ILLINOIS FED. AID PROJECT					

GENERAL PLAN & ELEVATION
 IL. RTE. 2 OVER
 TRIBUTARY TO ROCK RIVER
 STA. 635+63.70

STATE OF ILLINOIS
DEPARTMENT OF TRANSPORTATION

Benchmark:
Existing Structure: Built in 1952 as a single barrel 4'-0" x 2'-0" R.C. Box Culvert with a length of ±69'-0". Traffic to be Maintained Utilizing Stage Construction. No Salvage.

Proposed IL. F.A.P. RTE 742
(IL. RTE. 2)

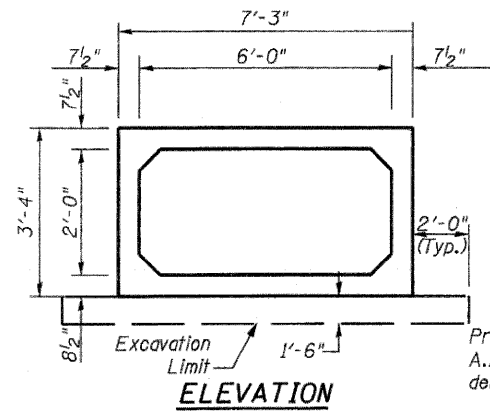
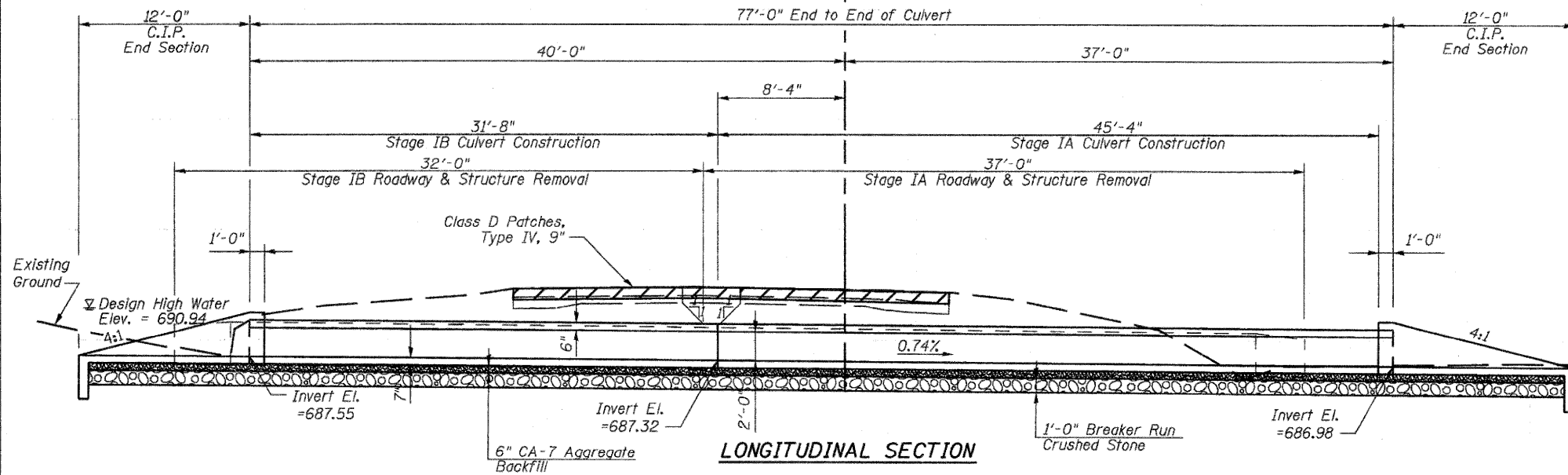

DESIGN STRESSES

$f_y = 60,000$ psi
 $f_y = 65,000$ psi (Welded Wire Fabric)
 $f'_c = 3,500$ psi
 $f'_c = 5,000$ psi (Precast)

PROFILE GRADE

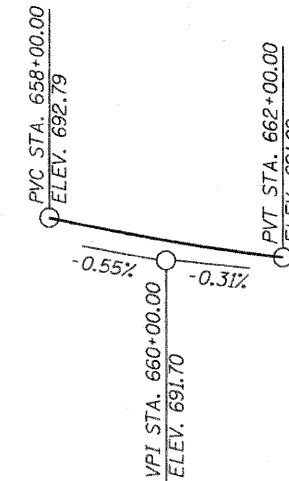

SHEET INDEX

NO.	DESCRIPTION
1	GENERAL PLAN
2	END SECTION DETAILS
3	BARREL DETAILS

DESIGN SPECIFICATIONS

2002 A.A.S.H.T.O. Specifications & Supplements
LOADING HS 20-44

Allow 50#/Sq. Ft. for future wearing surface

GENERAL NOTES

Precast Box shall conform to the requirements of A.A.S.H.T.O. M273 (A.S.T.M. C850). The maximum design fill height for this structure is 3'-0".

Culvert Concrete thickness shown shall be considered the minimum acceptable. Other thickness will be allowed if approved by the engineer.

Breaker-Run Crushed Stone to be placed as a subbase. Min. depth is 1'-0".

Work this sheet with Staging sheets.

Reinforcement bars shall conform to the requirements of ASTM A706 grade 60.

All construction joints shall be bonded.

Reinforcement bars designated (E) shall be epoxy coated.

The bars in the walls may be spliced as follows:

Bar Size Number	4	5	6	7	8
Minimum Splice Length	20"	26"	31"	43"	54"

This work shall be done according to the applicable portion of 503, 508, 540, and 542 of the standard specifications.

All exposed corners 90° or sharper shall be filleted with a 3/4" dressed and beveled strip.

Place 1/2" P.J.F. between pipe culvert and wall.

The contract unit price per Cu. Yd. for Concrete Box Culverts shall include the expansion bolts, J bolts, anchor bolts, bolts, nuts, washers, steel plates, P.J.F. earth excavation and backfilling as required.

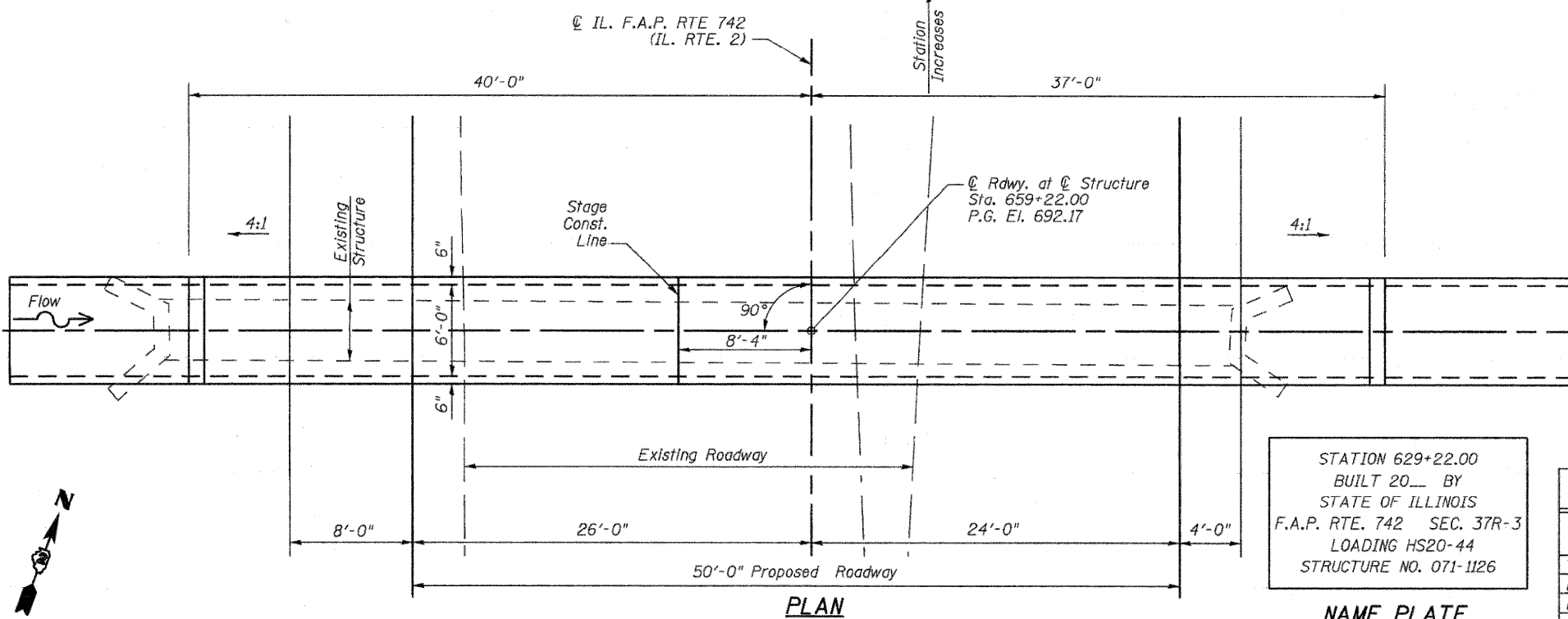

STATION 629+22.00
BUILT 20__ BY
STATE OF ILLINOIS
F.A.P. RTE. 742 SEC. 37R-3
LOADING HS20-44
STRUCTURE NO. 071-1126

NAME PLATE
See Std. 515001

WATERWAY INFORMATION TABLE

	Frequency Year	Discharge (cfs)	Waterway Opening Sq. Ft.		Natural H.W.E.	Head (ft)		Headwater Elev. (ft)	
			Existing	Proposed		Existing	Proposed	Existing	Proposed
Ten-Year	10	57	8.0	12.0		3.15	2.45	690.68	690.00
Design	50	79	8.0	12.0		3.63	3.39	691.16	690.94
Base	100	91	8.0	12.0		3.72	3.98	691.25	691.53
EX OVT	3	45	8.0	12.0		2.64		690.17	
PR OVT	118	94		12.0			4.76		692.31
Max Calc									

10-Year Velocity through Existing Structure = 9.5 fps
10-Year Velocity through Proposed Structure = 7.3 fps

TOTAL BILL OF MATERIALS

DESCRIPTION	UNIT	QTY.
Removal of Existing Structures No. 5	Each	1
Concrete Box Culverts	Cu. Yd.	11.2
Precast Concrete Box Culvert 6' X 2' (Special)	Foot	77
Breaker-Run Crushed Stone	Ton	78
Reinforcement Bars	Pound	1336

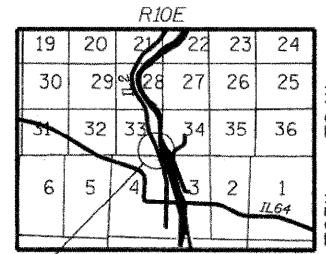

Project Location

LOCATION SKETCH

GENERAL PLAN & ELEVATION
IL. RTE. 2 OVER
TRIBUTARY TO ROCK RIVER
STA. 659+22.00

STATE OF ILLINOIS
DAVID F. MAXWELL
081-005455
ST. LOUIS, MO
REGISTERED STRUCTURAL ENGINEER

David F. Maxwell, S.E.
Reg. No. 081-005455
Date: 2/19/07
My registration expires November 30, 2010.

DESIGNED	CTH
CHECKED	DSG
DRAWN	EBS
CHECKED	DFM

SHEET NO. 1	F.A.P. RTE.	SECTION	COUNTY	TOTAL SHEETS	SHEET NO.
3 SHEETS	742	37 R-3	OGLE	345	186
SN 071-1126			CONTRACT NO. 84788		
FED. ROAD DIST. NO. 7 ILLINOIS FED. AID PROJECT					

STATE OF ILLINOIS
DEPARTMENT OF TRANSPORTATION

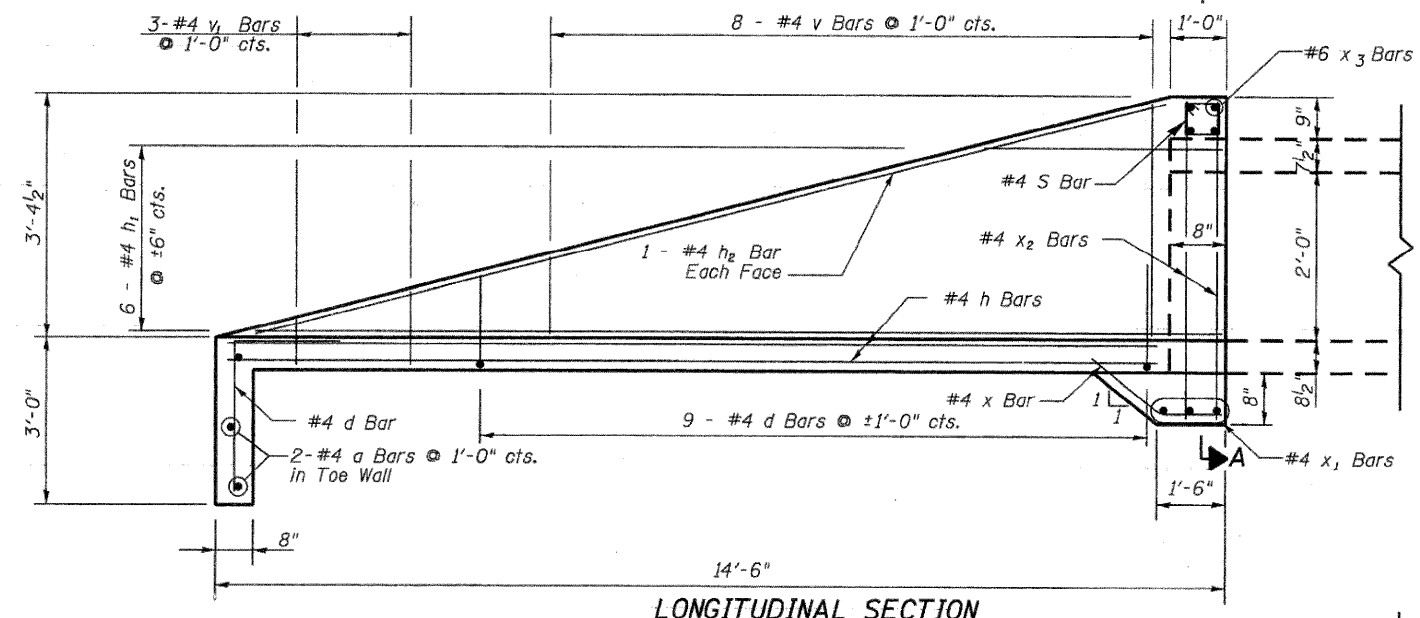

LONGITUDINAL SECTION

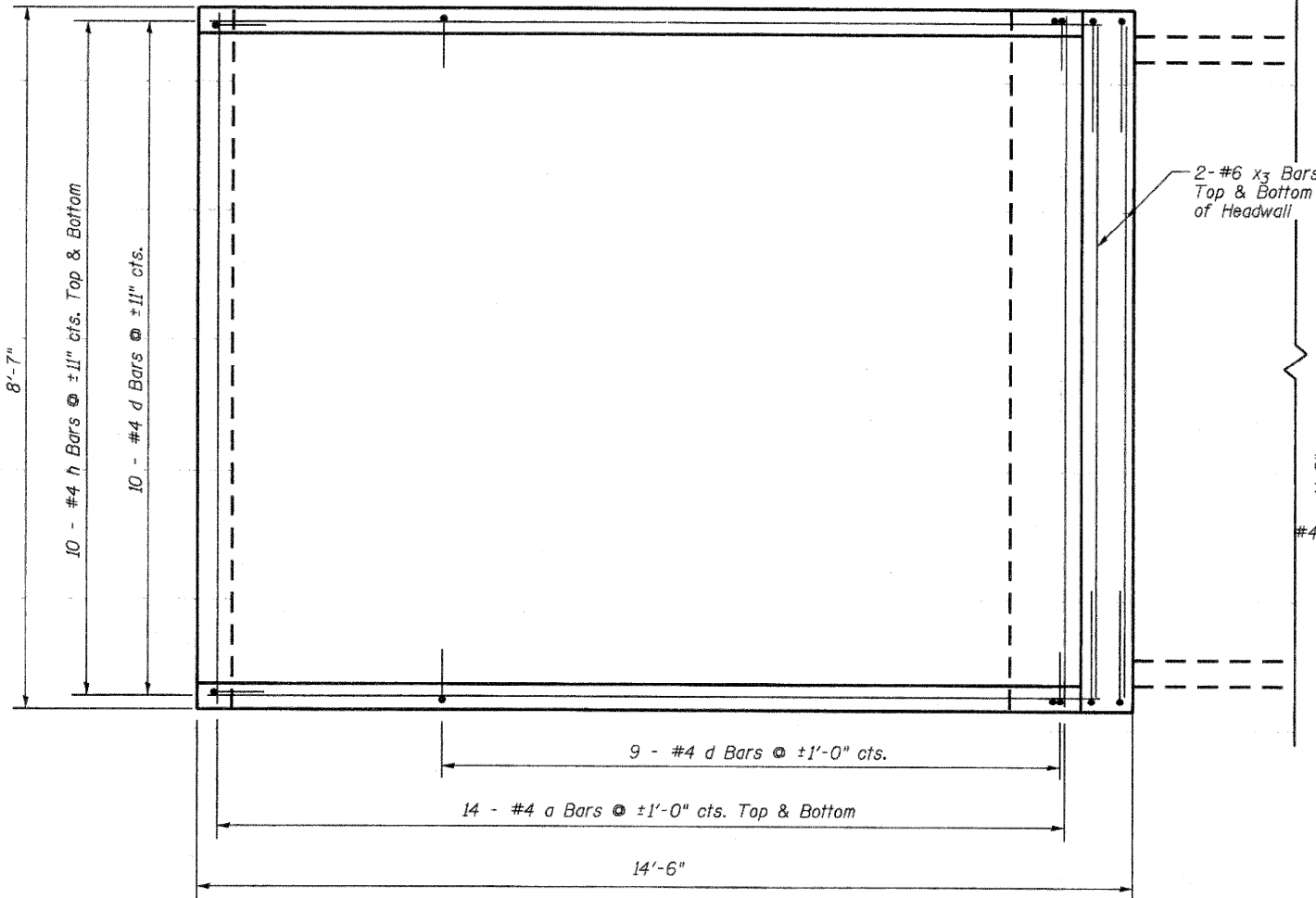

PLAN VIEW

DESIGNED	CTH
CHECKED	DSG
DRAWN	EBS
CHECKED	DFM

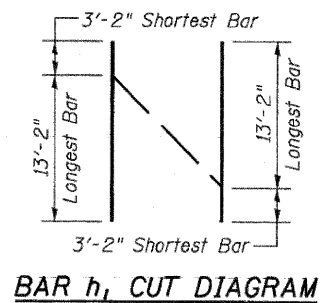

BAR h₁ CUT DIAGRAM

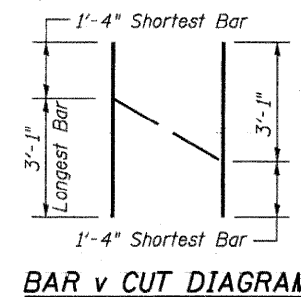

BAR v CUT DIAGRAM

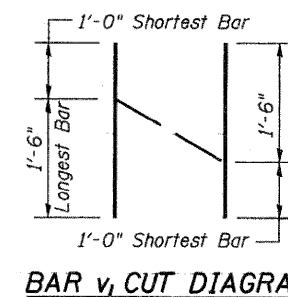

BAR v₁ CUT DIAGRAM

BILL OF MATERIALS *

BAR	NO.	SIZE	LENGTH	SHAPE	
a	30	#4	8'-4"	—	
d	28	#4	4'-6"	┌	
h	20	#4	13'-7"	—	
h ₁	6	#4	16'-4"	—	
h ₂	2	#4	12'-8"	—	
s	9	#4	3'-3"	□	
v	8	#4	4'-5"	—	
v ₁	3	#4	2'-6"	—	
x	9	#4	2'-9"	—	
x ₁	3	#4	8'-4"	—	
x ₂	4	#4	8'-0"	┌	
x ₃	4	#6	8'-4"	—	
			Concrete Box Culverts	Cu. Yd.	5.6
			Reinforcement Bars	Pound	668

* Quantities are for 1 End Section.

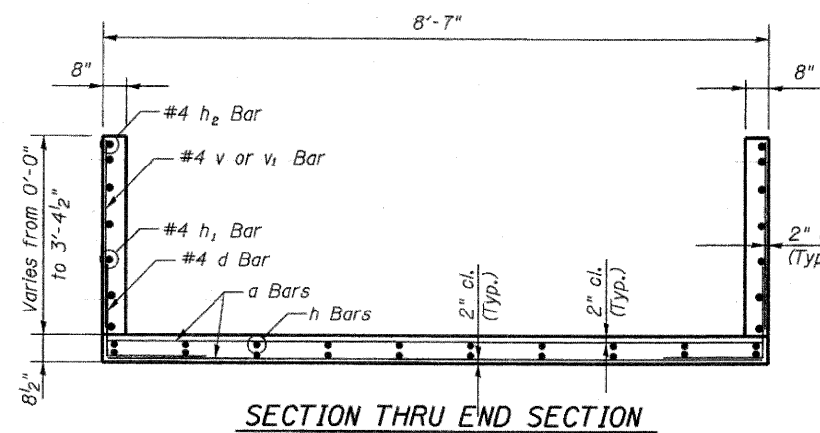

SECTION THRU END SECTION

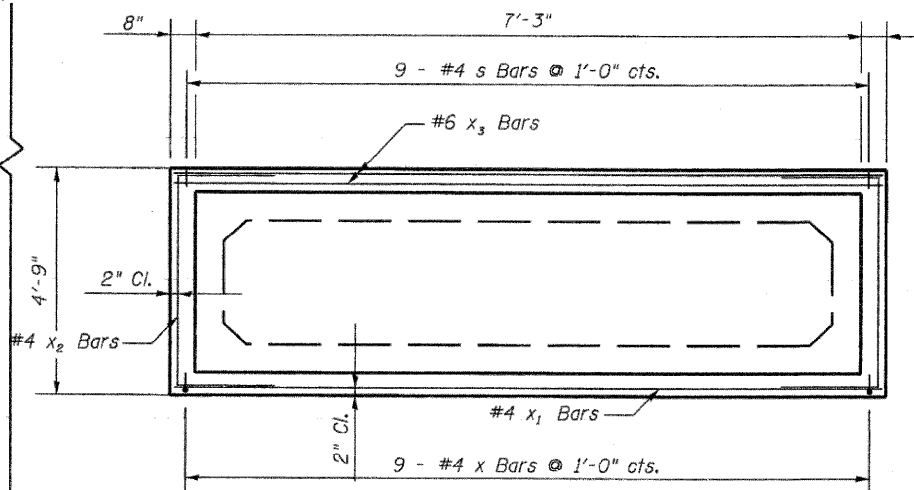

SECTION A-A

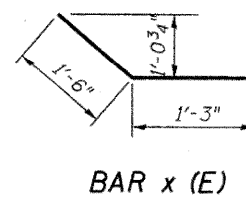

BAR x (E)

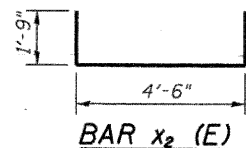

BAR x₂ (E)

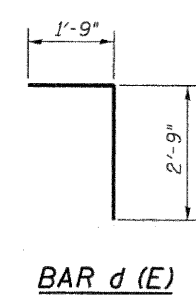

BAR d (E)

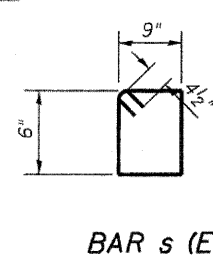

BAR s (E)

END SECTION DETAILS
IL. RTE. 2 OVER
TRIBUTARY TO ROCK RIVER
STA. 659+22.00

Howard R. Green Company

SHEET NO. 2 3 SHEETS	F.A.P. RTE. 742	SECTION 37 R-3	COUNTY OGLE	TOTAL SHEETS 345	SHEET NO. 187
	SN 071-1126		CONTRACT NO. 84788		
FED. ROAD DIST. NO. 7 ILLINOIS FED. AID PROJECT					

STATE OF ILLINOIS
DEPARTMENT OF TRANSPORTATION

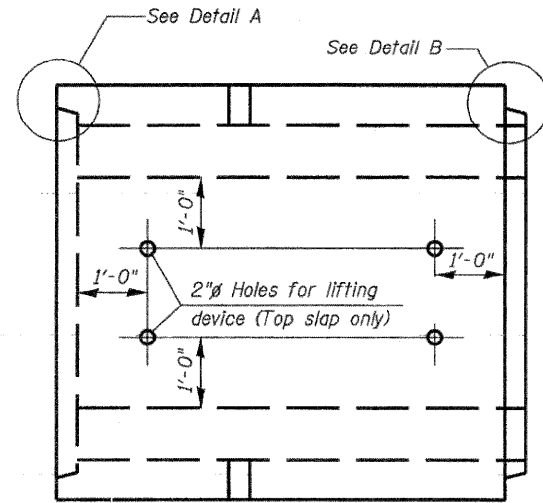

PLAN

Location of lifting holes may be varied as needed to clear reinf.

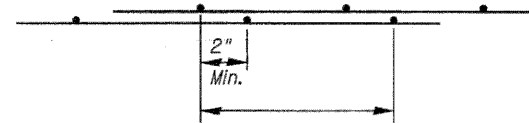

TYP. FABRIC LAP

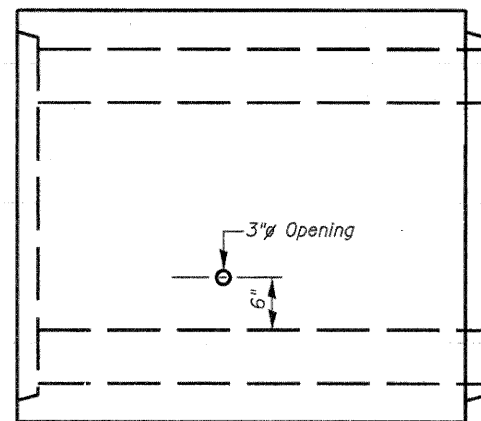

ELEVATION

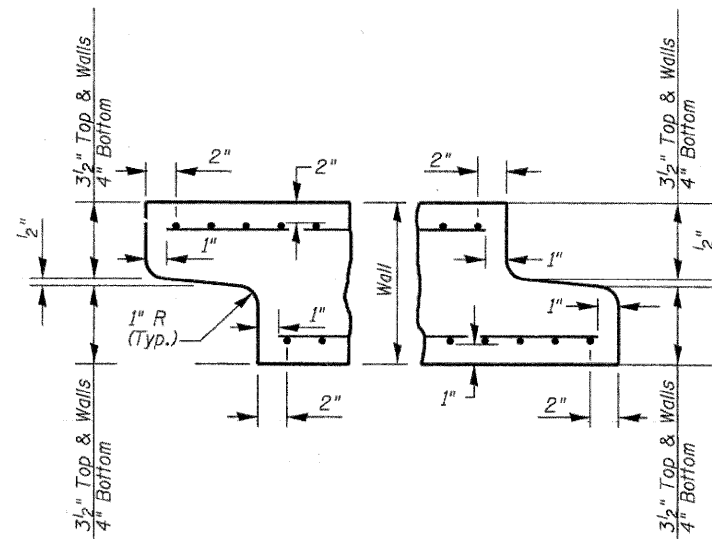

DETAIL A (Typ. Inlet End)
DETAIL B (Typ. Outlet End)

Note: Inlet and outlet ends shall be compatible.

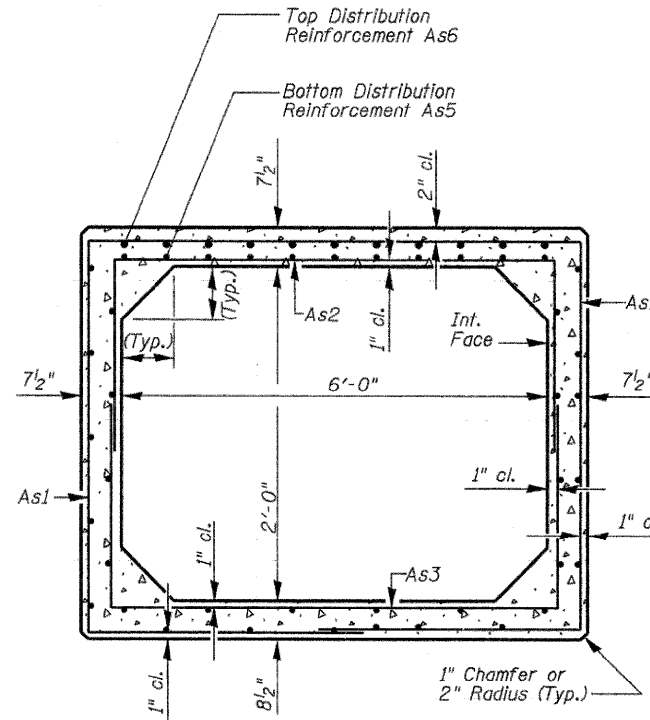

CROSS SECTION

GENERAL NOTES

Precast Concrete Box Culvert sections shall conform to the requirements of Article 540.0 of the Standard Specifications and the applicable requirements of AASHTO M 273.

The minimum concrete strength shall be 5,000 psi.

Reinforcement bars shall conform to the requirements of AASHTO M 31, M 42, or M 53 Grade 60.

Lifting holes shall be filled with concrete plugs and mastic after box sections are in place.

REQUIRED AASHTO STEEL AREAS (in²/ft.)

As1	0.496	As5	0.215
As2	0.400	As6	0.200
As3	0.400	As7	—
As4	—	As8	—

REINFORCEMENT PROVIDED

(To be filled out during construction)

REINFORCEMENT PROVIDED	AREA (in ² /ft.)
As1	___ x ___ W ___ x W ___ = ___
As2	___ x ___ W ___ x W ___ = ___
As3	___ x ___ W ___ x W ___ = ___
As4	provided by As2 and As3
As5	___ = ___
As6	___ = ___
As7	provided by As1
As8	provided by As1

BILL OF MATERIAL

ITEM	UNIT	TOTAL
Precast Concrete Box Culvert 6' X 2' (Special)	Ft.	77

BARREL DETAILS
IL. RTE. 2 OVER
TRIBUTARY TO ROCK RIVER
STA. 659+22.00

DESIGNED	CTH
CHECKED	DSG
DRAWN	EBS
CHECKED	DFM

Howard R. Green Company

SHEET NO. 3	F.A.P. RTE.	SECTION	COUNTY	TOTAL SHEETS	SHEET NO.
	742	37 R-3	OGLE	345	188
3 SHEETS	SN 071-1126		CONTRACT NO. 84788		
FED. ROAD DIST. NO. 7 ILLINOIS FED. AID PROJECT					

STATE OF ILLINOIS
DEPARTMENT OF TRANSPORTATION

Benchmark: Railroad Spike in Tree at Sta. 681+71.11, 64.04' LT. Elev. = 675.738
Existing Structure: Built in 1923 as a Single Barrel 12'-0" X 3'-0" R.C. Box Culvert, at proposed IL. Rte. 2 station 677+97 with a Culvert Length of ±32'-0". Traffic to be Maintained Utilizing Stage Construction. No Salvage.

DESIGN STRESSES

Field Units
f_y = 60,000 psi
f'c = 3,500 psi

SHEET INDEX

NO.	DESCRIPTION
1	GENERAL PLAN & ELEVATION
2	GENERAL NOTES & TOTAL BILL OF MATERIAL
3	STAGING PLAN
4	TEMPORARY CONCRETE BARRIER
5	CULVERT DETAILS
6	BAR SPlicer ASSEMBLY DETAILS
7	BORING LOG

DESIGN SPECIFICATIONS

2002 A.A.S.H.T.O. Specifications
LOADING HS 20-44
Allow 50#/Sq. Ft. for future wearing surface

HORIZONTAL CURVE DATA

IL Rte. 2
P.I. Sta. = 682+45.19
Δ = 27°33'30.5" (LT)
D = 3°49'11"
R = 1,500.00'
T = 367.86'
L = 721.48'
E = 44.45'
S.E. = 0.054'/'
P.C. Sta. = 678+77.33
P.T. Sta. = 685+98.81

NOTES

See sheet 2 for General Notes.

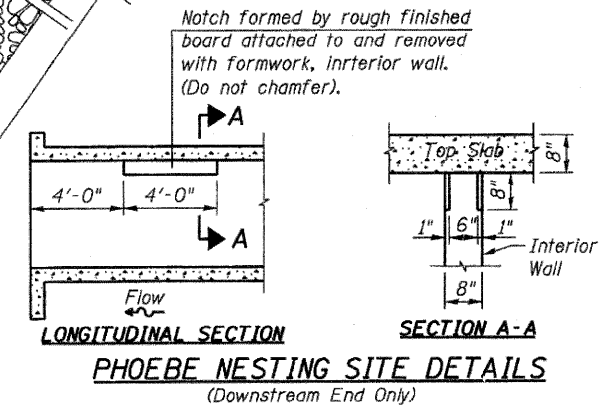
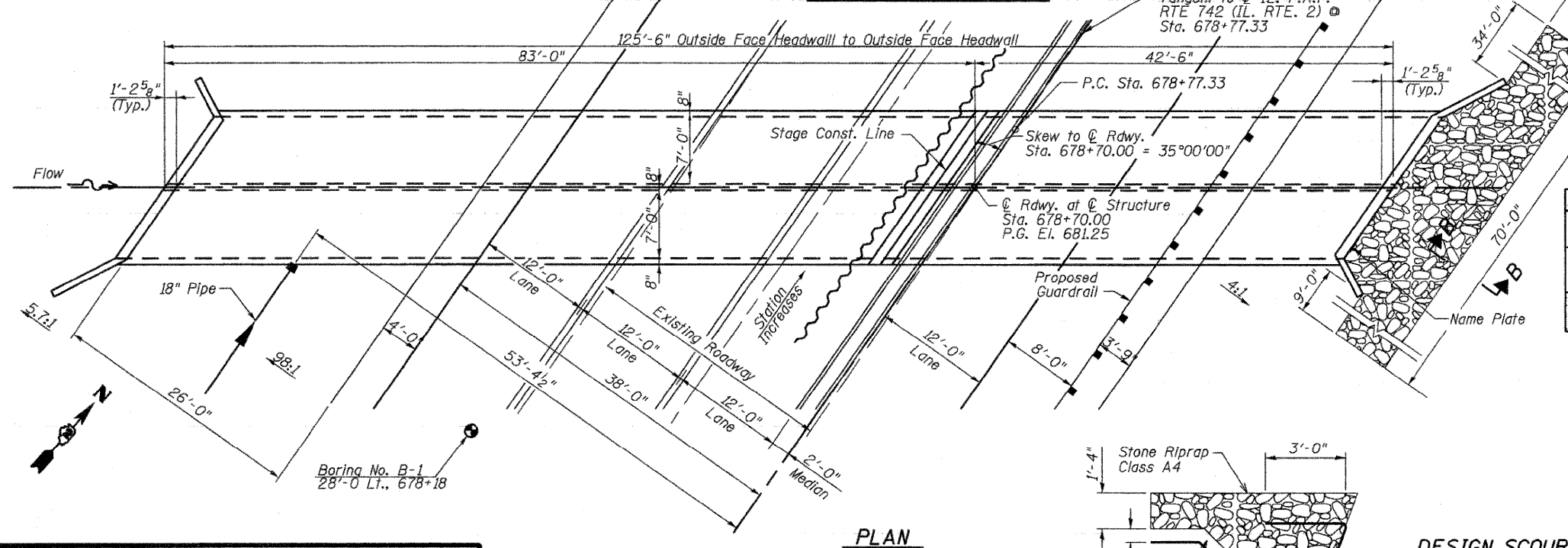
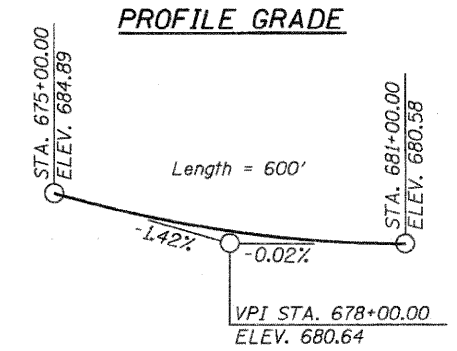
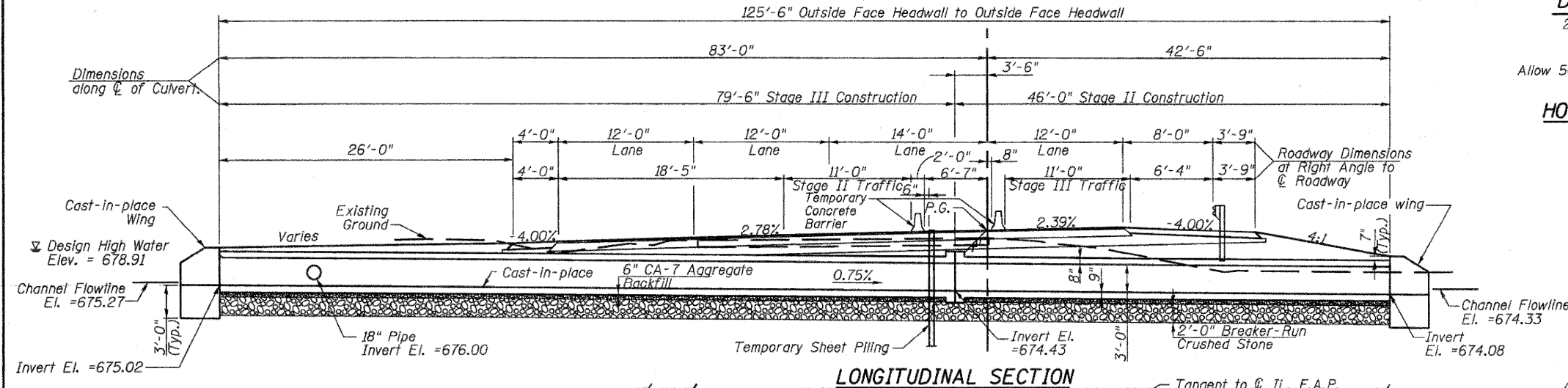

STATION 678+70.00
BUILT 20__ BY
STATE OF ILLINOIS
F.A.P. RTE. 742 SEC. 37R-3
LOADING HS20-44
STRUCTURE NO. 071-1127

NAME PLATE
See Std. 515001

WATERWAY INFORMATION TABLE

Drainage Area = 0.30 sq. mi.	Existing Low Grade Elevation: 680.22 ft. @ Sta. 678+43.00	
	Proposed Low Grade Elevation: 680.53 ft. @ Sta. 684+00.00	

DESIGN SCOUR ELEVATION TABLE

Design Scour Elevation (ft.)	Upstream	Downstream
	672.27	671.33

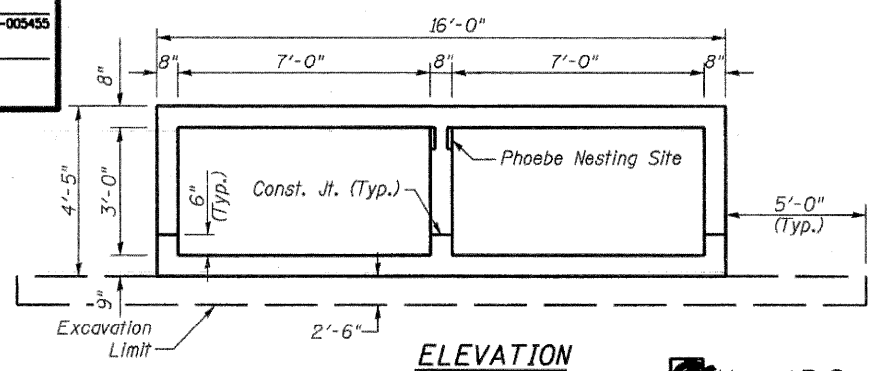
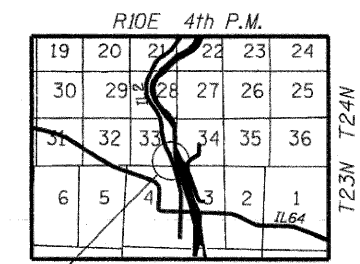
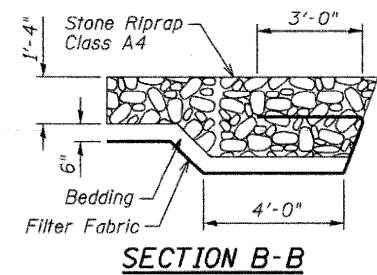

STATE OF ILLINOIS
DAVID F. MAXWELL
081-005455
ST. LOUIS, MO.
REGISTERED STRUCTURAL ENGINEER

David F. Maxwell, S.E.
Reg. No. 081-005455
Date: 2/19/09
My registration expires November 30, 2010.

DESIGNED	DFM
CHECKED	CTH
DRAWN	CTH
CHECKED	DSG

APPROVED
FOR STRUCTURAL ADEQUACY ONLY

Ralph E. Anderson
ENGINEER OF BRIDGES AND STRUCTURES

Howard R. Green Company

SHEET NO. 1 7 SHEETS	F.A.P. RTE. 742	SECTION 37 R-3	COUNTY OGLE	TOTAL SHEETS 345	SHEET NO. 189
	SN 071-1127		CONTRACT NO. 84788		
FED. ROAD DIST. NO. 7 ILLINOIS FED. AID PROJECT					

GENERAL PLAN & ELEVATION
IL. ROUTE 2 OVER
TRIBUTARY TO ROCK RIVER
STA. 678+70.00

10-Year Velocity through Existing Structure = 8.6 fps
10-Year Velocity through Proposed Structure = 9.0 fps

STATE OF ILLINOIS
DEPARTMENT OF TRANSPORTATION

TOTAL BILL OF MATERIALS

DESCRIPTION	UNIT	QTY.
Removal and Disposal of Unsuitable Material	Cu. Yd.	239.1
Stone Riprap, Class A4	Sq. Yd.	245.9
Filter Fabric	Sq. Yd.	245.9
Removal of Existing Structures No. 7	Each	1
Reinforcement Bars	Pound	32,790
Bar Splicers	Each	85
Temporary Sheet Piling *	Sq. Ft.	1321.8
Name Plates	Each	1
Concrete Box Culverts	Cu. Yd.	143
Breaker-Run Crushed Stone	Ton	457

* See Sheet Piling Design on Sheet 3 of 7.

GENERAL NOTES

For Stage I details see staging sheets.

Precast alternate not allowed.

Reinforcement bars shall conform to the requirements of ASTM A 706 Gr 60.

Reinforcement bars designated (E) shall be epoxy coated.

Layout of the slope protection system may be varied to suit ground conditions in the field as directed by the engineer.

A distance of one half the length of the wingwall but not less than six feet of the barrel shall be poured monolithically with the wingwalls.

All exposed corners 90° or sharper shall be filleted with a 3/4" dressed and beveled strip.

The bars in the walls may be spliced as follows:

Bar Size Number	4	5	6	7	8
Minimum Splice Length	20"	26"	31"	43"	54"

All construction joints shall be bonded.

Reinforcement bars designated (E) shall be epoxy coated.

Bars indicated thus 4 X 2-#4 indicates 4 lines of bars with 2 lengths per line.

The contract unit price per Cu. Yd. for Concrete Box Culverts shall include the expansion bolts, J bolts, anchor bolts, bolts, nuts, washers, steel plates, earth excavation and backfilling as required.

GENERAL NOTES & TOTAL BILL OF MATERIALS

**IL. ROUTE 2 OVER
TRIBUTARY TO ROCK RIVER
STA. 678+70.00**

DESIGNED	CTH
CHECKED	DSG
DRAWN	EBS
CHECKED	DFM

 Howard R. Green Company

SHEET NO. 2	F.A.P. RTE.	SECTION	COUNTY	TOTAL SHEETS	SHEET NO.
	742	37 R-3	OGLE	345	190
7 SHEETS	SN 071-1127		CONTRACT NO. 84788		
FED. ROAD DIST. NO. 7 ILLINOIS FED. AID PROJECT					

STATE OF ILLINOIS
DEPARTMENT OF TRANSPORTATION

NOTES

If the Contractor chooses to alter the temporary sheet piling design requirements shown on the plans, a design submittal including plan details and calculations will be required for review and acceptance by the Engineer.

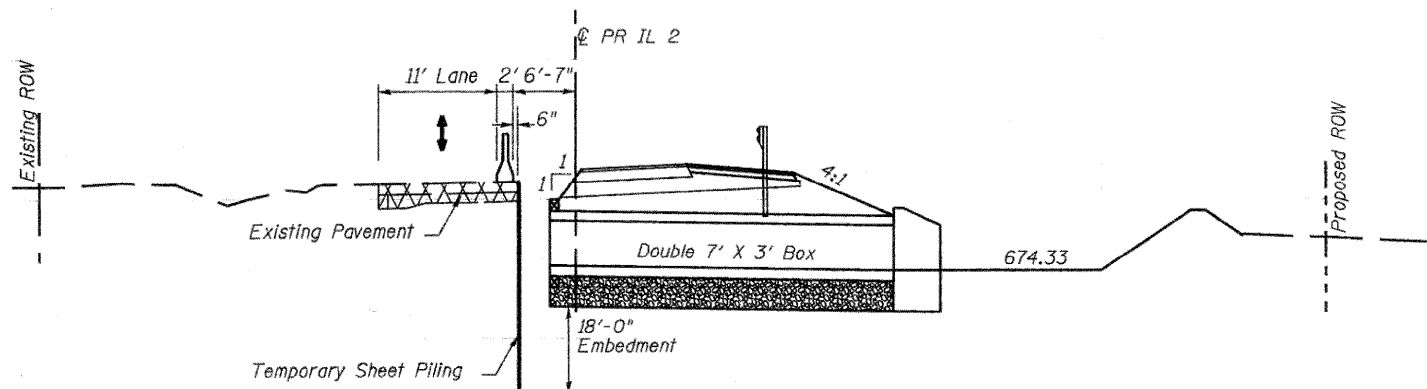

STAGE II CONSTRUCTION

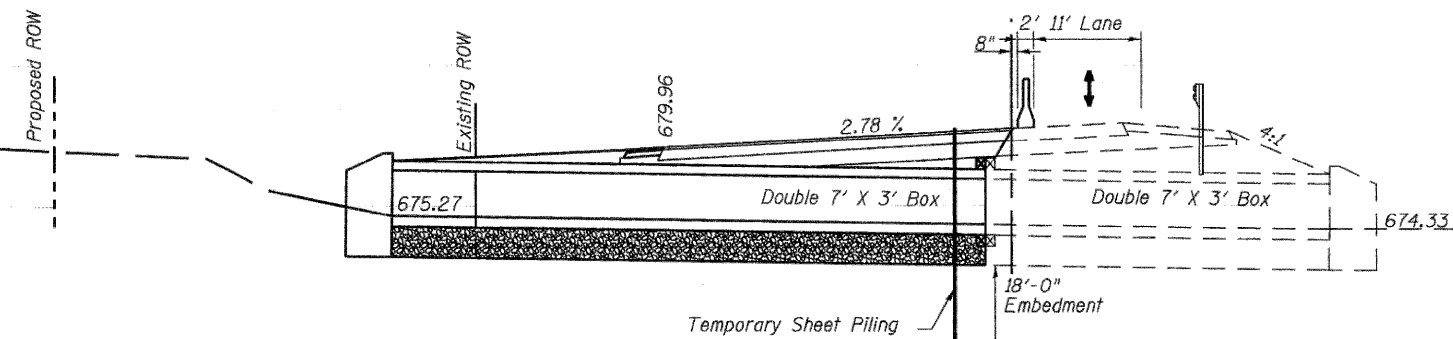

STAGE III CONSTRUCTION

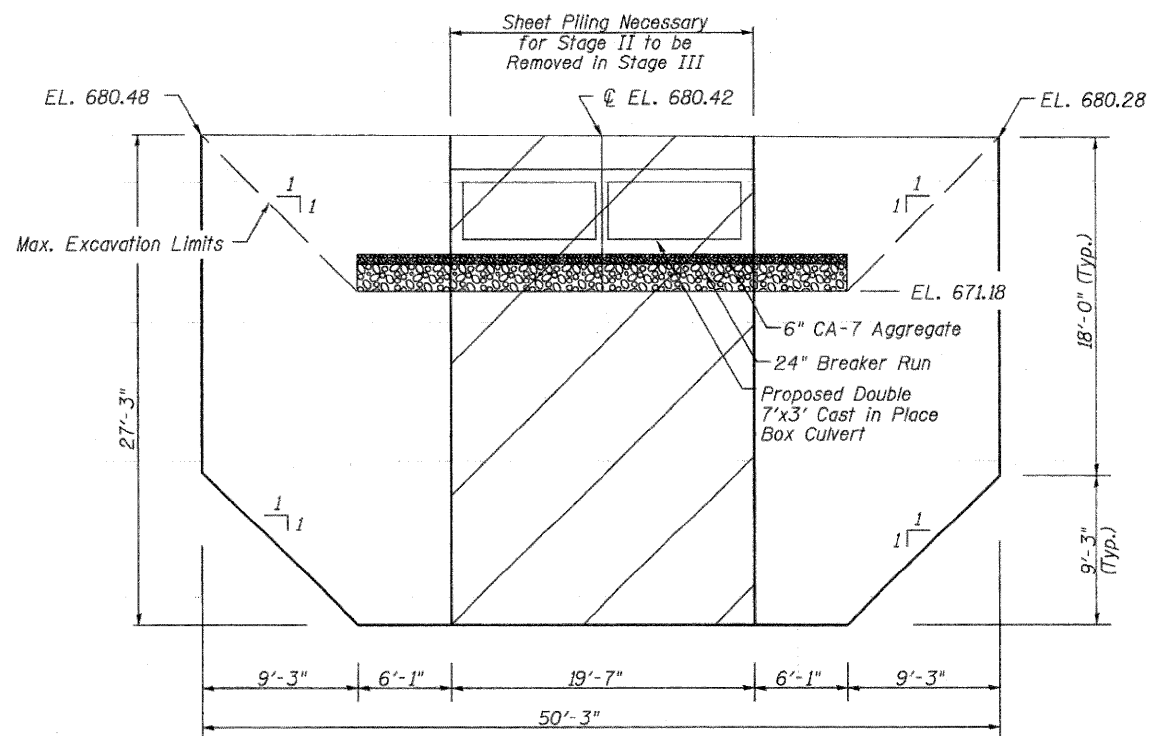

TEMPORARY SHEET PILING DETAIL
(Looking East)

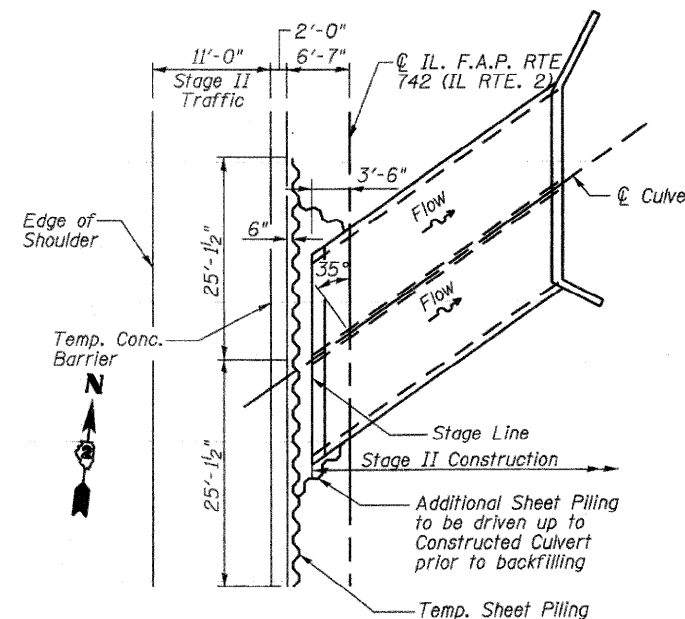

PLAN - STAGE II
(NTS)

Temporary Sheet Piling Data:

Embedment: 18'-0" Beyond Max. Excavation
(Min.) Section Modulus: 13.65 in/ft.
Fy: 38,500 psi.

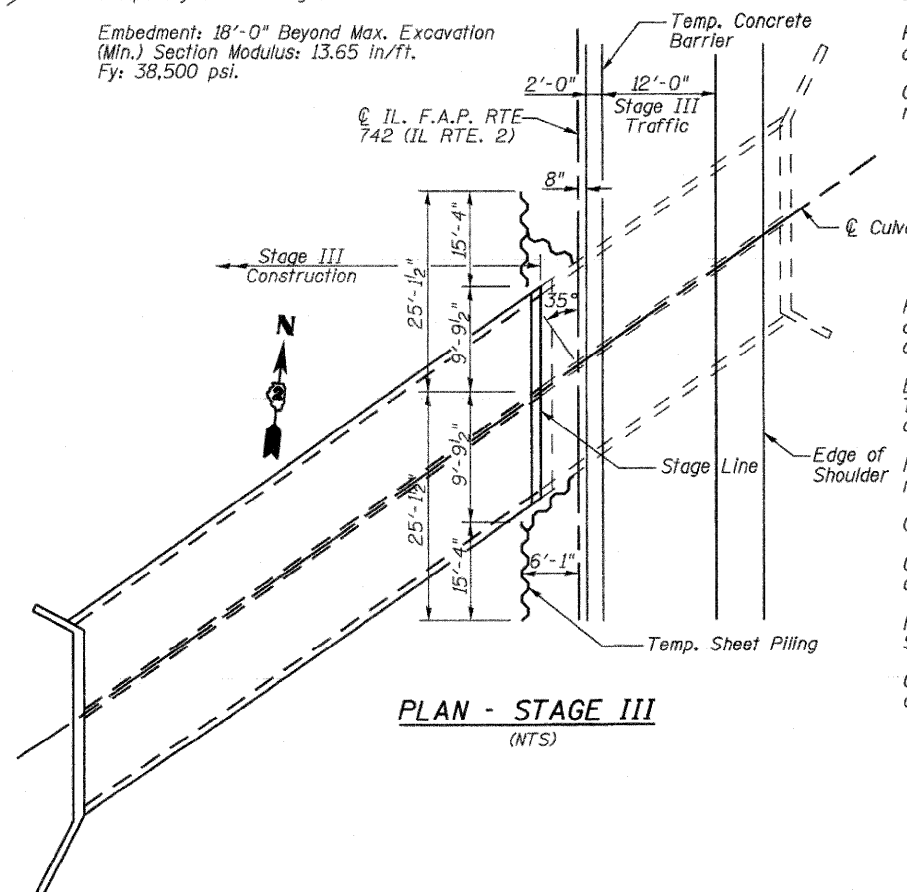

PLAN - STAGE III
(NTS)

STAGE II CONSTRUCTION

Install Temporary Concrete Barriers as shown to provide a single lane of traffic on the west side of the roadway.

Install Temporary Sheet Piling as shown.

Excavate embankment east of the Temporary Sheet Piling as required for construction of the new box culvert.

Construct new box culvert to limits shown.

Install additional sheet piling outside the limits of the proposed culvert from the sheet piling to the constructed portion of the new culvert.

Place required backfill behind completed portion of box culvert for construction of roadway.

Construct proposed embankment and proposed roadway on east side of road as shown.

STAGE III CONSTRUCTION

Reuse Temporary Concrete Barriers as shown to allow a single lane of traffic on west portion of new roadway completed in Stage II.

Excavate remainder of the embankment west of the Temporary Sheet Piling as needed for construction of the new box culvert.

Remove portion of sheet piling within the limits of the new box culvert as needed for construction of the culvert.

Construct new box culvert to limits shown.

Complete required backfill behind box culvert for construction of roadway.

Remove Temporary Sheet Piling after completion of Stage III Construction.

Construct proposed embankment and proposed roadway on west side of road as shown.

STAGING PLAN
IL. ROUTE 2 OVER
TRIBUTARY TO ROCK RIVER
STA. 678+70.00

DESIGNED	DFM
CHECKED	CTH
DRAWN	CTH
CHECKED	DSG

SHEET NO. 3	F.A.P. RTE.	SECTION	COUNTY	TOTAL SHEETS	SHEET NO.
	742	37 R-3	OGLE	345	191
7 SHEETS	SN 071-1127		CONTRACT NO. 84788		
FED. ROAD DIST. NO. 7 ILLINOIS FED. AID PROJECT					

STATE OF ILLINOIS
DEPARTMENT OF TRANSPORTATION

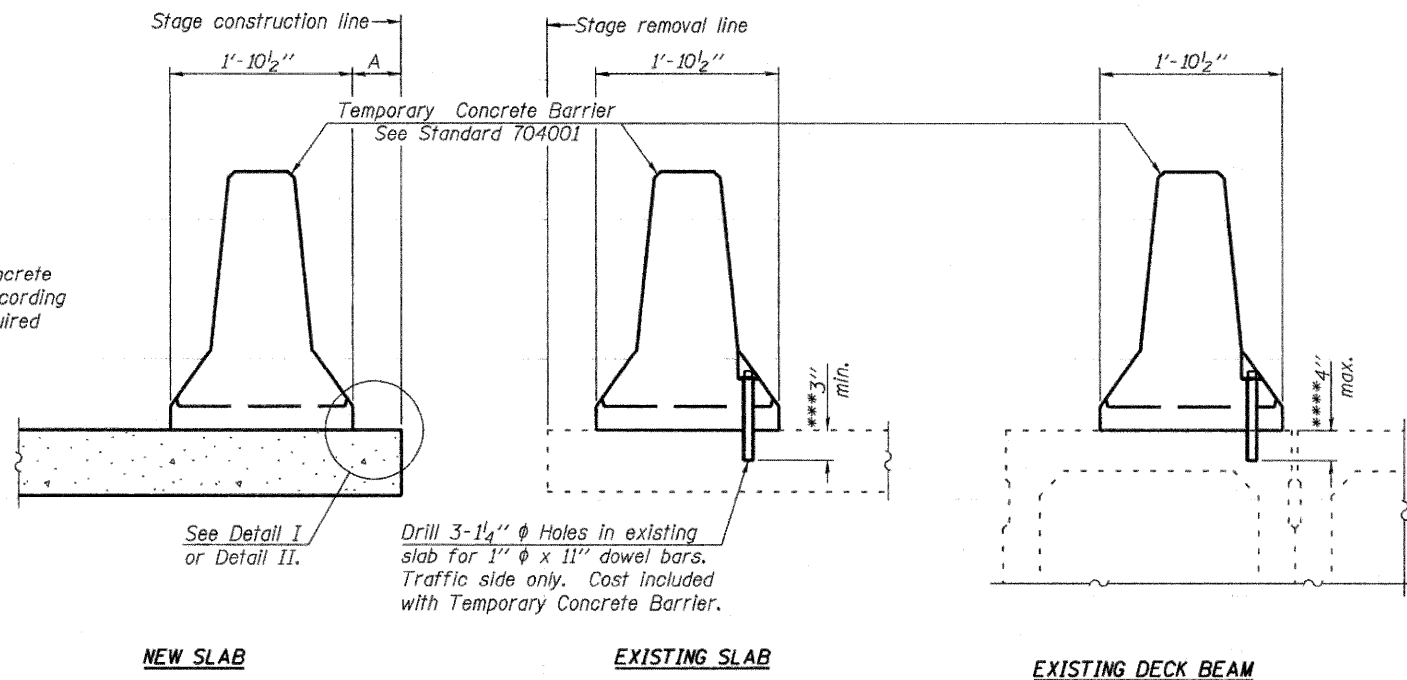

When "A" is 3'-6" or less, the temporary concrete barrier shall be anchored to the new slab according to Detail I or Detail II. No anchorage is required when "A" is greater than 3'-6".

See Detail I or Detail II.

Drill 3-1/4" ϕ Holes in existing slab for 1" ϕ x 11" dowel bars. Traffic side only. Cost included with Temporary Concrete Barrier.

- NOTES**
- Detail I - With Bar Splicer or Couplers:
Connect one (1) 1"x7"x10" steel \bar{P} to the top layer of couplers with 2-5/8" ϕ bolts screwed to coupler at approximate \bar{C} of each barrier panel.
- Detail II - With Extended Reinforcement Bars:
Connect one (1) 1"x7"x10" steel \bar{P} to the concrete slab or concrete wearing surface with 2-5/8" ϕ Expansion Anchors or cast in place inserts spaced between the top layer of reinforcement at approximate \bar{C} of each barrier panel.
- Cost of anchorage is included with Temporary Concrete Barrier. The 1" x 7" x 10" plate shall not be removed until stage II construction forms and all reinforcement bars are in place and the concrete is ready to be placed.

SECTIONS THRU SLAB OR DECK BEAM

*** Dimension shown is minimum required embedment into concrete. If hot-mix asphalt wearing surface is present, minimum embedment shall be in addition to wearing surface depth.

**** If existing deck beam is to remain in place after stage construction, embedment shall only be into wearing surface and not into existing deck beam concrete.

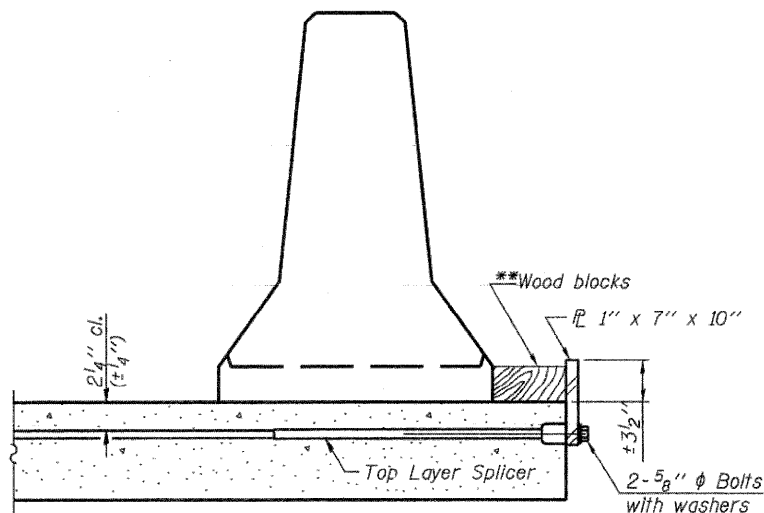

DETAIL I

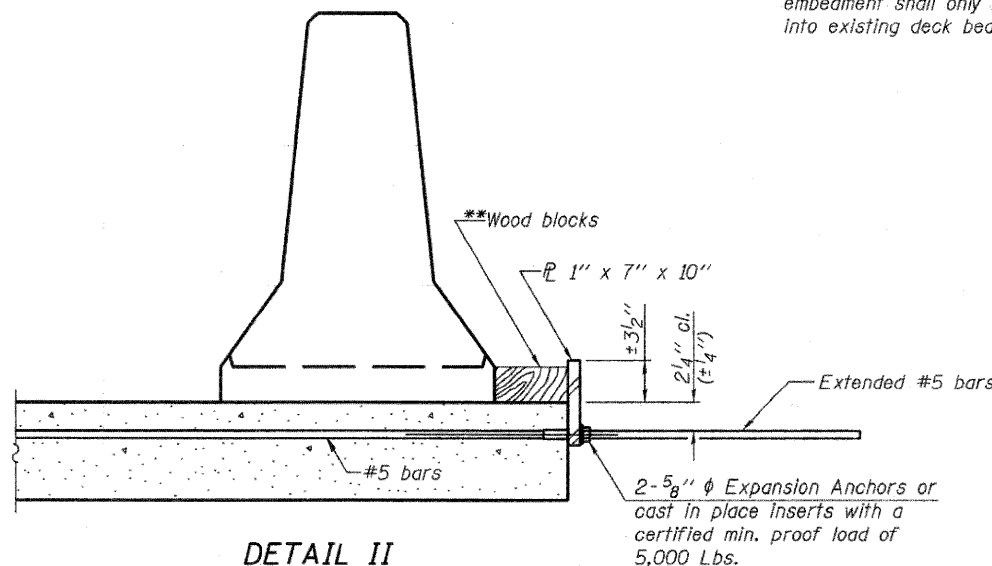

DETAIL II

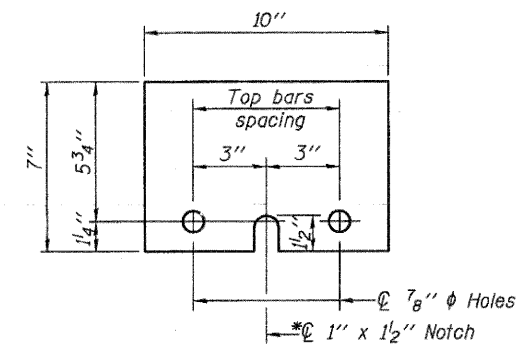

STEEL RETAINER \bar{P} 1" x 7" x 10"

* Required only with Detail II

**Wood blocks may be omitted when required to provide minimum stage traffic lane width. When the wood blocks are omitted, the concrete barrier shall be in direct contact with the steel retainer plate.

TEMPORARY CONCRETE BARRIER
IL. ROUTE 2 OVER
TRIBUTARY TO ROCK RIVER
STA. 678+70.00

DESIGNED	DFM
CHECKED	CTH
DRAWN	CTH
CHECKED	DSG

R-27

10-1-08

Howard R. Green Company

SHEET NO. 4	F.A.P. RTE.	SECTION	COUNTY	TOTAL SHEETS	SHEET NO.
	742	37 R-3	OGLE	345	192
7 SHEETS	SN 071-1127		CONTRACT NO. 84788		
FED. ROAD DIST. NO. 7 ILLINOIS FED. AID PROJECT					

STATE OF ILLINOIS
DEPARTMENT OF TRANSPORTATION

(Back)
2-#4 h7 bars at 1'-0" cts. Short Wing
2-#5 h10 bars at 10" cts. Long Wing

(Front)
4-#4 h7 bars at 1'-0" cts. Short Wing
4-#5 h10 bars at 10" cts. Long Wing

Bend in Field, typ.
7-#5 h6 bars at 10" cts. Long Wing
5-#4 h8 bars at 1'-0" cts. Short Wing

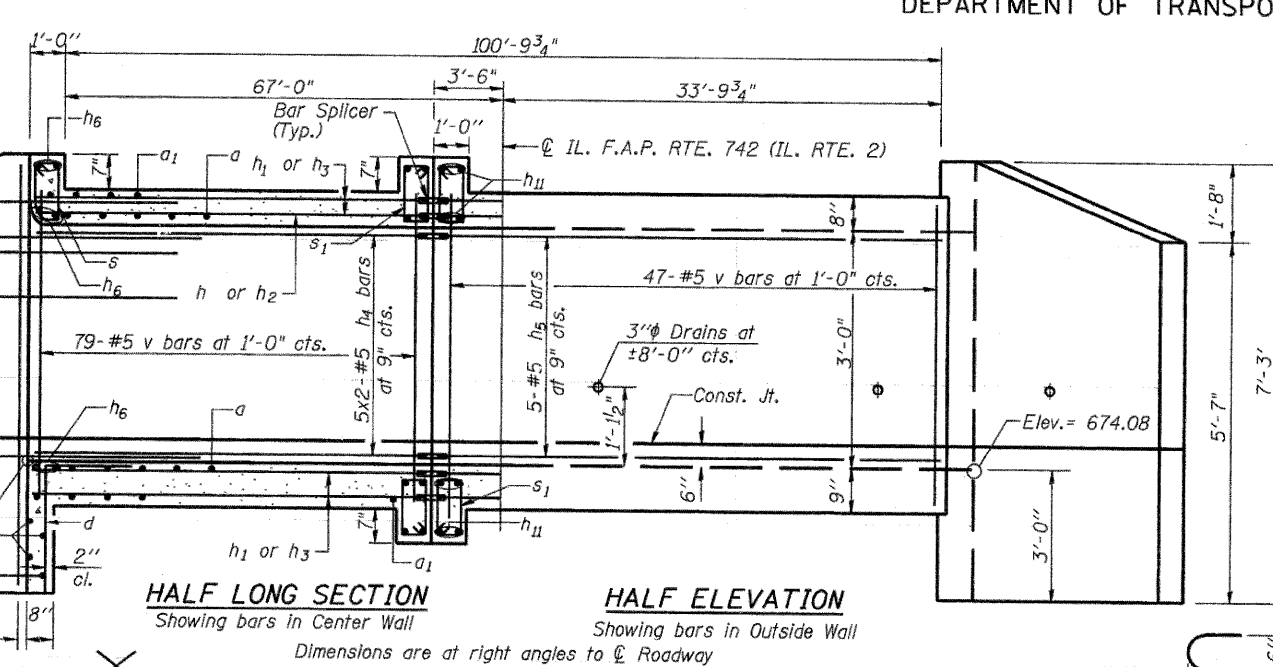

HALF LONG SECTION
Showing bars in Center Wall

HALF ELEVATION
Showing bars in Outside Wall

Dimensions are at right angles to C Roadway

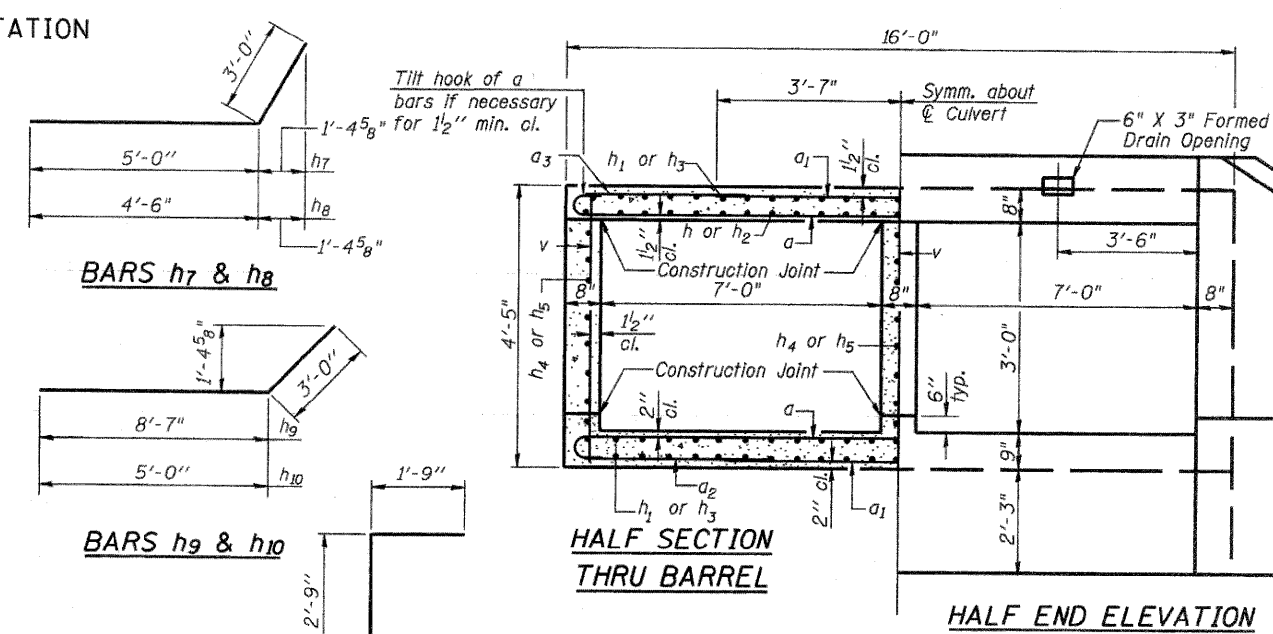

HALF SECTION THRU BARREL

HALF END ELEVATION

NOTES

Bars indicated thus 12x4-#5 etc. indicates 12 lines of bars with 4 lengths per line.
Field cut bars intersecting 18" RCP.

BILL OF MATERIAL

Bar	No.	Size	Length	Shape
a	500	#6	17'-0"	C
a1	500	#6	7'-2"	—
a2	124	#4	5'-8"	—
a3	166	#5	6'-0"	—
d	30	#4	4'-6"	—
h	32	#6	40'-8"	—
h1	108	#4	40'-2"	—
h2	16	#6	46'-4"	—
h3	54	#4	46'-4"	—
h4	30	#5	40'-5"	—
h5	15	#5	46'-4"	—
h6	18	#6	17'-7"	—
h7	12	#4	8'-0"	—
h8	10	#4	7'-6"	—
h9	14	#5	11'-7"	—
h10	12	#5	8'-0"	—
h11	16	#6	19'-2"	—
s	18	#4	4'-1"	—
s1	94	#4	4'-3"	—
v	382	#5	4'-2"	—
v1	8	#4	7'-0"	—
v2	8	#5	7'-0"	—
v3	8	#5	3'-1"	—
Reinforcement Bars			Pound	32,790
Bar Splicers			Each	85
Concrete Box Culverts			Cu. Yd.	143

CULVERT DETAILS
IL. ROUTE 2 OVER
TRIBUTARY TO ROCK RIVER
STA. 678+70.00

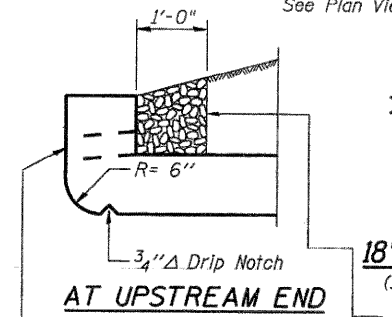

18" RCP OPENING DETAIL
(See sheet 1 of 7 for location)

Coarse aggregate full length of both headwalls. To be placed by Grading Contractor. Cost included with Concrete Box Culverts.

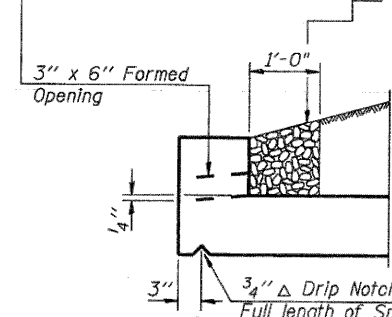

DRAIN DETAIL

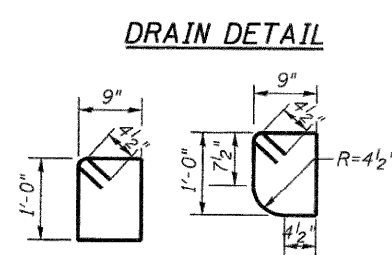

BAR s1 (E) BAR s (E)

DESIGNED	DFM
CHECKED	CTH
DRAWN	CTH
CHECKED	DSG

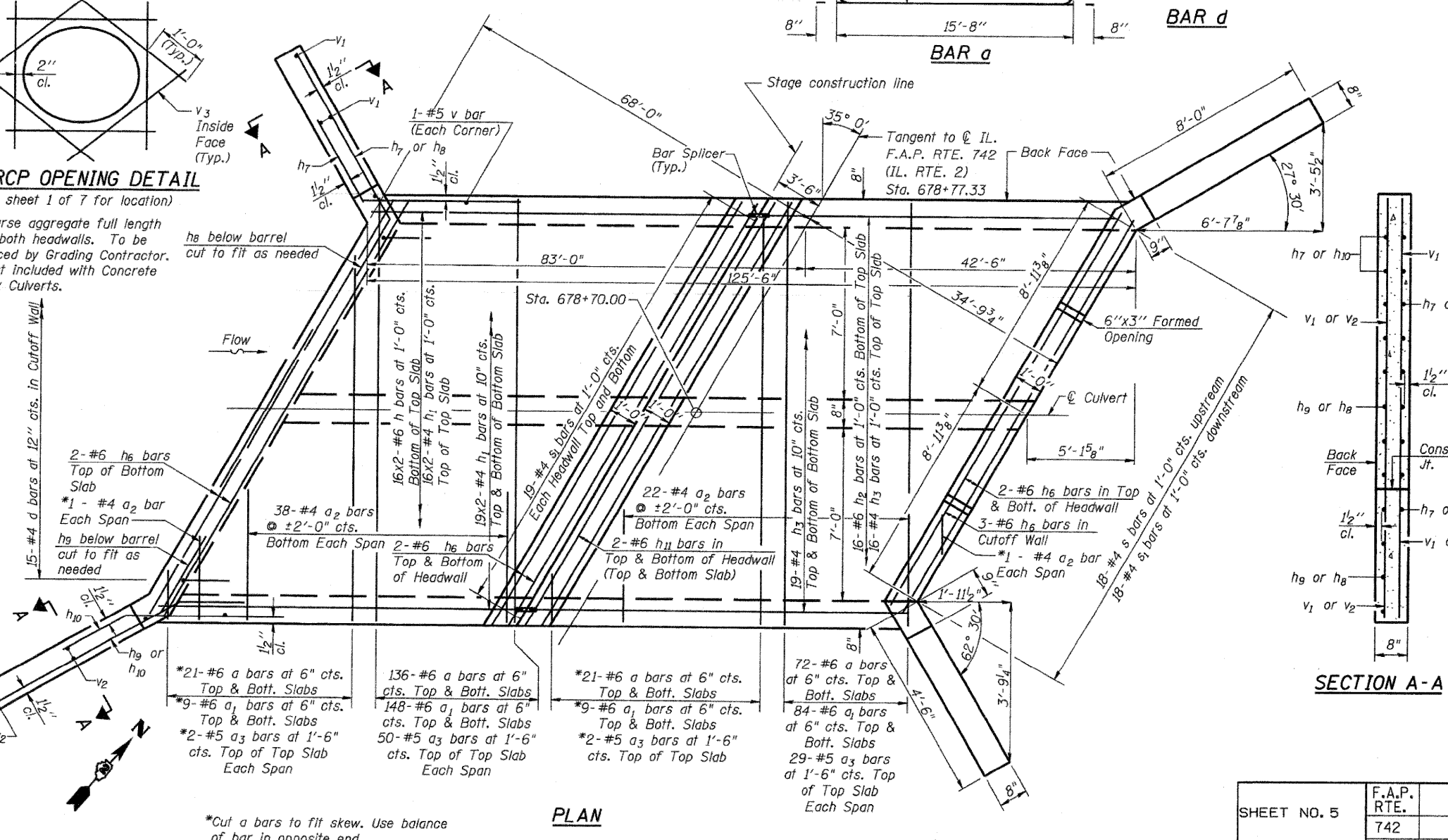

PLAN

*Cut a bars to fit skew. Use balance of bar in opposite end.

SHEET NO. 5	F.A.P. RTE.	SECTION	COUNTY	TOTAL SHEETS	SHEET NO.
	742	37 R-3	OGLE	345	193
7 SHEETS	SN 071-1127		CONTRACT NO. 84788		
	FED. ROAD DIST. NO. 7 ILLINOIS FED. AID PROJECT				

STATE OF ILLINOIS
DEPARTMENT OF TRANSPORTATION

The diameter of this part is equal or larger than the diameter of bar spliced.

The diameter of this part is the same as the diameter of the bar spliced.

ROLLED THREAD DOWEL BAR



**** ONE PIECE**

Wire Connector

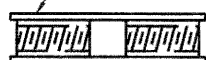

WELDED SECTIONS

BAR SPLICER ASSEMBLY ALTERNATIVES

**Heavy Hex Nuts conforming to ASTM A 563, Grade C, D or DH may be used.

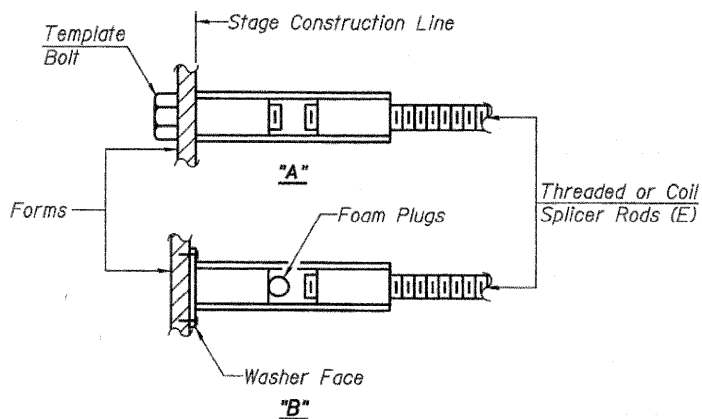

INSTALLATION AND SETTING METHODS

"A" : Set bar splicer assembly by means of a template bolt.

"B" : Set bar splicer assembly by nailing to wood forms or cementing to steel forms.

(E) : Indicates epoxy coating.

NOTES

Bar splicer assemblies shall be of an approved type and shall develop in tension at least 125 percent of the yield strength of the lapped reinforcement bars.

Splicer rods shall be of minimum 60 ksi yield strength, threaded or coiled full length.

All reinforcement bars shall be lapped and tied to the splicer rods or dowel bars.

Bar splicer assemblies shall be epoxy coated according to the requirements for reinforcement bars.

Other systems of similar design may be submitted to the Engineer for approval. Approval shall be based on certified test results from an approved testing laboratory that the proposed bar splicer assembly satisfies the following requirements:

- ① Minimum Capacity (Tension in kips) = $1.25 \times f_y \times A_t$
 - ② Minimum *Pull-out Strength (Tension in kips) = $0.66 \times f_y \times A_t$
- Where f_y = Yield strength of lapped reinforcement bars in ksi.
 A_t = Tensile stress area of lapped reinforcement bars.
 * = 28 day concrete

BAR SPLICER ASSEMBLIES			
Bar Size to be Spliced	Splicer Rod or Dowel Bar Length	Strength Requirements	
		Min. Capacity kips - tension	Min. Pull-Out Strength kips - tension
#4	1'-8"	14.7	7.9
#5	2'-2"	23.0	12.3
#6	2'-7"	33.1	17.4
#7	3'-5"	45.1	23.8
#8	4'-6"	58.9	31.3
#9	5'-9"	75.0	39.6
#10	7'-3"	95.0	50.3
#11	9'-0"	117.4	61.8

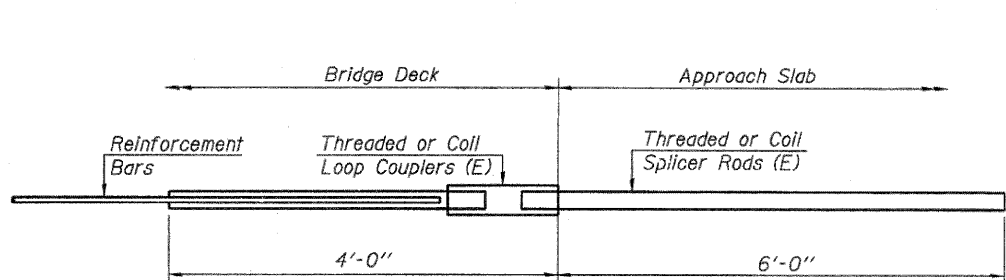

FOR INTEGRAL OR SEMI-INTEGRAL ABUTMENTS

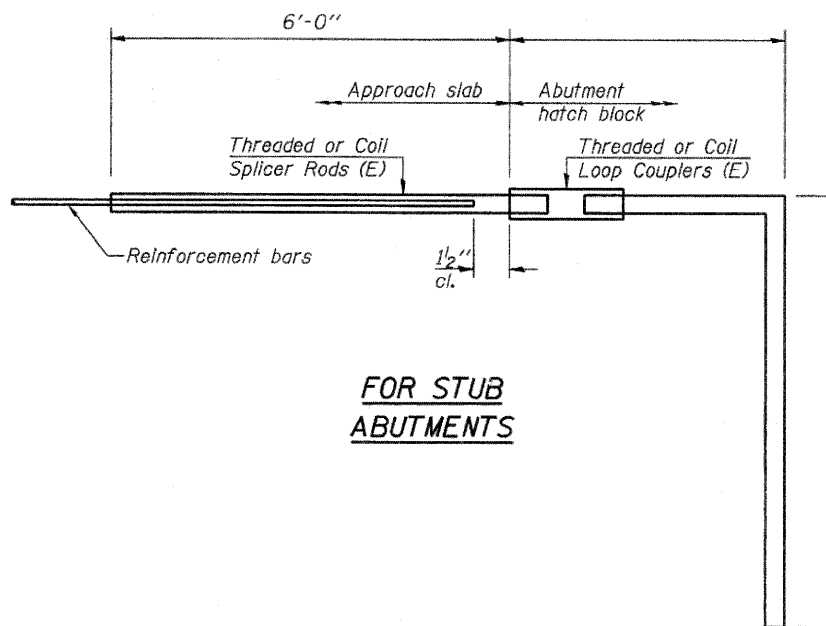

FOR STUB ABUTMENTS

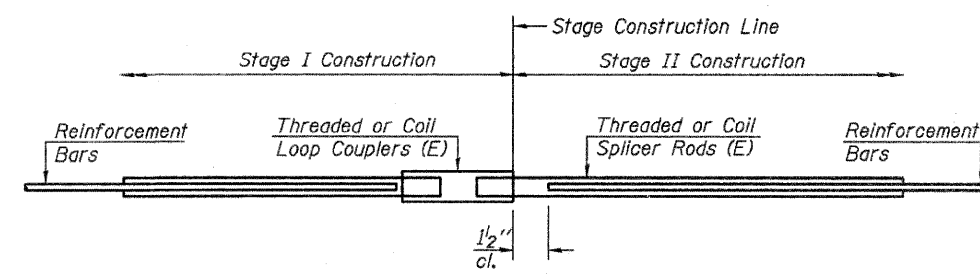

STANDARD

Bar Size	No. Assemblies Required	Location
#4	54	Bottom Slab & Top of Top Slab
#5	15	Walls
#6	16	Bottom of Top Slab

Bar Splicer for #5 bar
Min. Capacity = 23.0 kips - tension
Min. Pull-out Strength = 12.3 kips - tension
No. Required =

Bar Splicer for #5 bar
Min. Capacity = 23.0 kips - tension
Min. Pull-out Strength = 12.3 kips - tension
No. Required =

DESIGNED DFM
CHECKED CTH
DRAWN CTH
CHECKED DSG

BSD-1

10-1-08

Howard R. Green Company

**BAR SPLICER ASSEMBLY DETAILS
IL. ROUTE 2 OVER
TRIBUTARY TO ROCK RIVER
STA. 678+70.00**

SHEET NO. 6	F.A.P. RTE.	SECTION	COUNTY	TOTAL SHEETS	SHEET NO.
	742	37 R-3	OGLE	345	194
7 SHEETS	SN 071-1127		CONTRACT NO. 84788		
FED. ROAD DIST. NO. 7 ILLINOIS FED. AID PROJECT					

STATE OF ILLINOIS
DEPARTMENT OF TRANSPORTATION

ILLINOIS DEPARTMENT OF TRANSPORTATION
District Two Materials
Rockvale Twp. - NE 1/4 Sec. 33 - T24N, R10E

Units Metric
Bridge Foundation
Boring Log

PROJECT BRIDGE IL 2 over ditch Date 06/28/96
3.22 km North of IL 64
ROUTE FA 742 (IL 2) North of Oregon Bored By C. Jenkins
SEC. 37RS-3 STA. 1905 + 60 Checked By T. Bratt

COUNTY Ogle	D E P T H	N	Qu kPa	W %	Surf Wat El. 98.60 Grndwater El. at Compl. Wash At Hrs	D E P T H	N	Qu kPa	W %	Penetration
Ground Surface	99.39	0m								
VERY SOFT brown SILTY CLAY LOAM			00	21	VERY LOOSE brown river SAND & GRAVEL	-7				2 1 3
MEDIUM brown river SAND & GRAVEL	-1		4 6 5		LOOSE brown SAND & GRAVEL					3 2 3
Streambed Elev. -98.55			0.4							
SOFT brown SILTY CLAY LOAM			3 3 5	38 B	LOOSE Same as above					3 2 3
First Encounter V VERY SOFT brown SILTY CLAY			2 4 5	19 B	LOOSE Same as above	-9				2 3 3
VERY SOFT Same as above	-3		2 1 3	19 B	VERY DENSE yellow SANDSTONE					100/76mm PEN
VERY SOFT Same as above			1 1 2	00 E						
VERY SOFT gray SILTY CLAY			1 4 1	00 P	VERY DENSE Same as above	-11				100/51mm PEN
MEDIUM brown river SAND & GRAVEL			2 4 13		END OF BORING					
Begin Wash LOOSE Same as above			6 2 -6			-13				

N-Std Penetr. Test: 5cm OD Sampler,
63.5Kg Hammer, 76cm Fall (Fall. B-Bulge S-Shear E-Estimated P-Penetrometer)

BORING LOG
IL. ROUTE 2 OVER
TRIBUTARY TO ROCK RIVER
STA. 678+70.00

DESIGNED	DFM
CHECKED	CTH
DRAWN	CTH
CHECKED	DSG

SHEET NO. 7 7 SHEETS	F.A.P. RTE.	SECTION	COUNTY	TOTAL SHEETS	SHEET NO.
	742	37 R-3	OGLE	345	195
SN 071-1127			CONTRACT NO. 84788		
FED. ROAD DIST. NO. 7 ILLINOIS FED. AID PROJECT					

DROP BOX NO. 1

LT STA 615+22

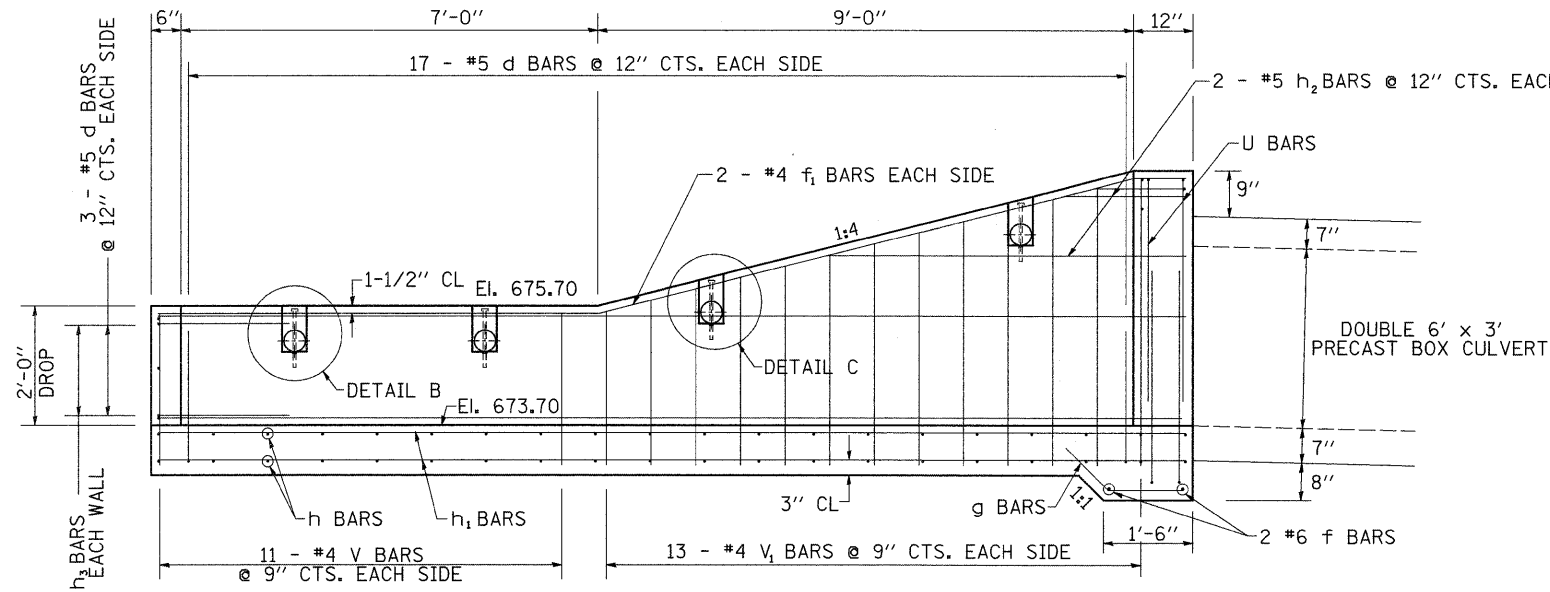

SIDEWALLS

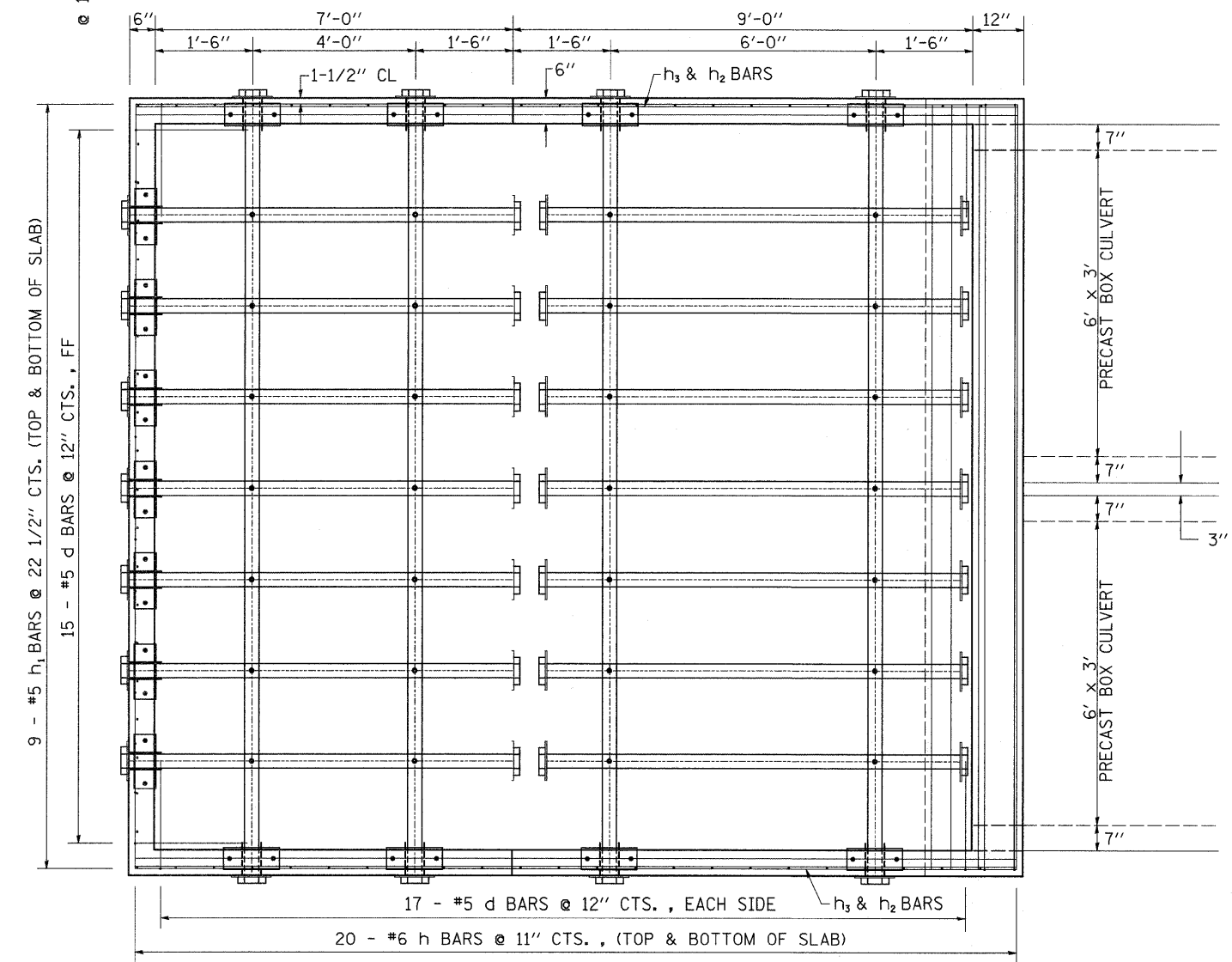

BOTTOM SLAB

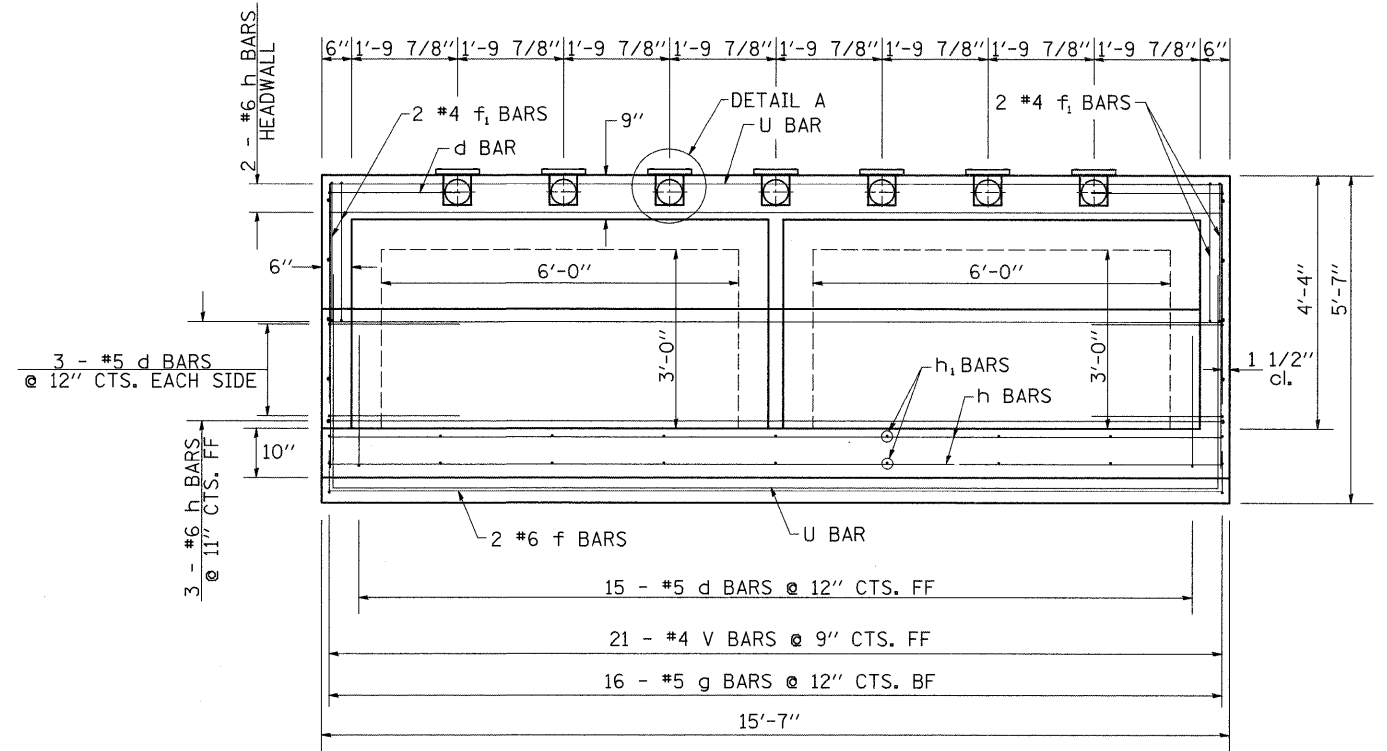

FRONT VIEW

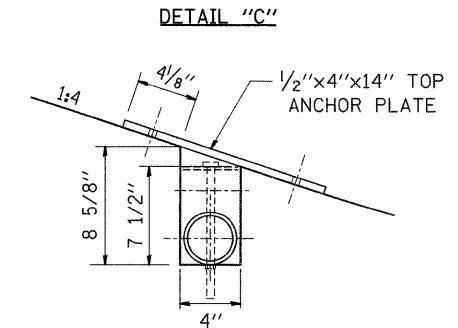
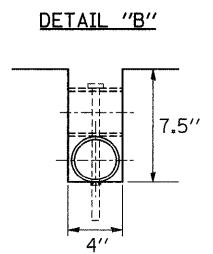
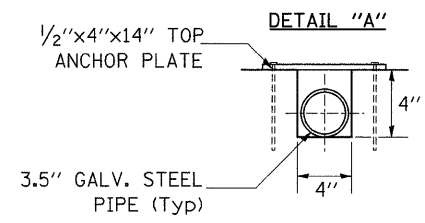

FILE NAME =	USER NAME = cushmanbw	DESIGNED -	REVISED -	STATE OF ILLINOIS DEPARTMENT OF TRANSPORTATION	DROP BOX NO. 1			F.A.P. RTE.	SECTION	COUNTY	TOTAL SHEETS	SHEET NO.
ct:\pw_work\FWIDDOT\CUSHMANBW\dms34123\dms34123.dgn	6486culv.dgn	DRAWN -	REVISED -					742	37R-3	OGLE	345	196
PLOT SCALE = 50.0000' / IN.	CHECKED -	REVISED -	CONTRACT NO. 84788									
PLOT DATE = Fri May 01 08:27:28 2009	DATE -	REVISED -	ILLINOIS FED. AID PROJECT									
				SCALE:	SHEET NO.	OF	SHEETS	STA.	TO STA.			

DROP BOX NO. 1

LT STA 615 + 22

BILL OF MATERIAL

(For Information Only)

BAR	SIZE	NO.	LENGTH	SHAPE
d	5	57	4'-4"	
f	6	2	15'-4"	
f1	4	4	17'-5"	
g	5	16	2'-2"	
h	6	45	15'-4"	
h1	5	18	17'-3"	
h2	5	2	8'-0"	
h3	5	6	17'-3"	
v	4	43	2'-5"	
v1	4	13	7'-2"	
u	5	4	23'-2"	
DESCRIPTION			UNIT	QTY
CONCRETE STRUCTURES			CU YD	11.54
REINFORCEMENT BARS			LB	2100
DESCRIPTION			UNIT	QTY.
3.5" GALVANIZED STEEL PIPE			7'-6"	7
			9'-1"	7
			15'-7"	4
3.5" GALVANIZED PIPE CAPS			EACH	36
1/4" GALVANIZED STEEL PLATE (9" NOMINAL)			EACH	15
1/2"x4"x14" GALVANIZED STEEL PLATE			EACH	15
5/8"x9" GALVANIZED STEEL BOLTS			EACH	58

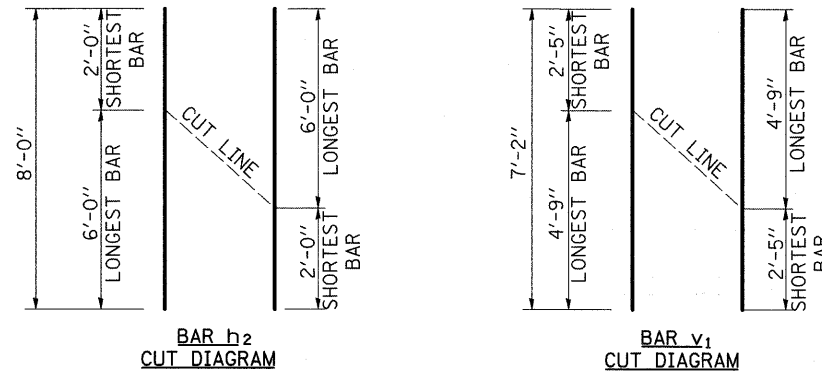

BAR h₂
CUT DIAGRAM

BAR v₁
CUT DIAGRAM

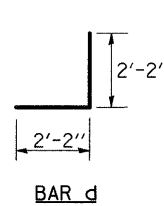

BAR d

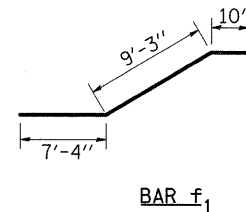

BAR f₁

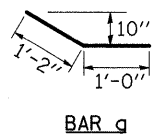

BAR g

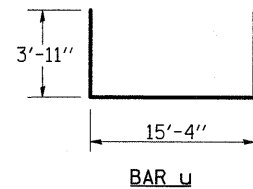

BAR u

GENERAL NOTES:

This work shall be paid for at the contract unit price per Each for Drop Box No. 1.

Contractor shall field verify Galvanized pipe length.

Exposed edges shall be beveled 3/4".

The contract unit price "each" for DROP BOX NO. 1 shall include the Expansion Bolts, Galvanized Pipe, Pipe Caps, Concrete Structures, Reinforcement Bars, Bolts, Nuts, Washers, Steel Plates, earth excavation where required, and necessary grading to fit the Inlet as shown in the cross sections or to the slope.

Reinforcement bars shall conform to the requirements of ASTM A 706 Gr. 60 (IL Modified). See Special Provisions.

Steel Plates shall conform to AASHTO M-183 and shall be Galvanized conforming to AASHTO M-111.

Bolts, Nuts, and Washers shall be in accordance with Article 505 of the Standard Specification and shall be galvanized.

See Plan & Profile Sheet for more information.

See Cross Section Sheet for more information.

FILE NAME =	USER NAME = cushmanbw	DESIGNED -	REVISED -	STATE OF ILLINOIS DEPARTMENT OF TRANSPORTATION	DROP BOX NO. 1			F.A.P RTE.	SECTION	COUNTY	TOTAL SHEETS	SHEET NO.
o:\pw_work\PWDOT\CUSHMANBW\dms34123\dms34123.dwg	6486culv.dgn	DRAWN -	REVISED -					742	37R-3	OGLE	345	197
PLOT SCALE = 50.0000' / IN.	CHECKED -	REVISED -	REVISED -					CONTRACT NO. 84788				
PLOT DATE = Fri May 01 08:27:29 2009	DATE -	REVISED -	REVISED -					SCALE:	SHEET NO.	OF	SHEETS	STA.

DROP BOX NO. 2

LT STA 626 + 61

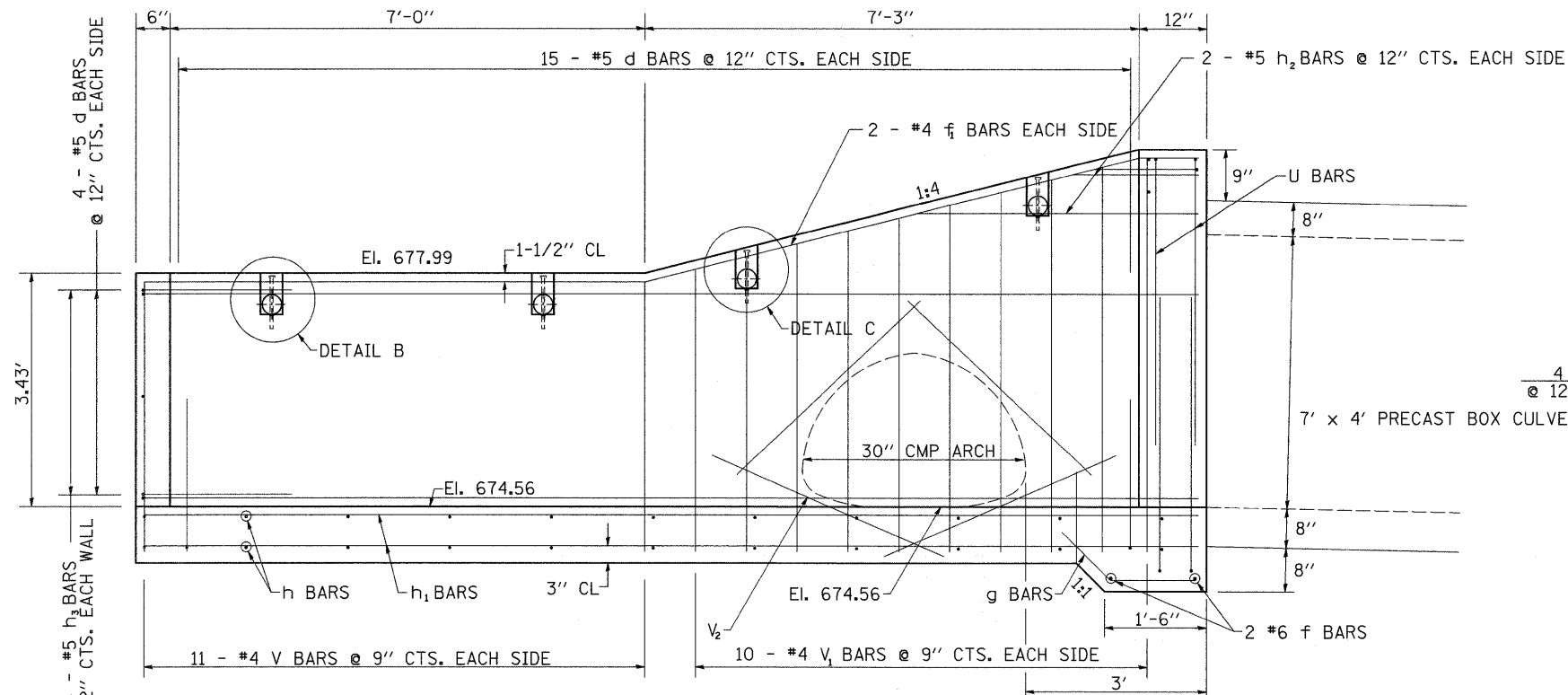

SIDEWALLS

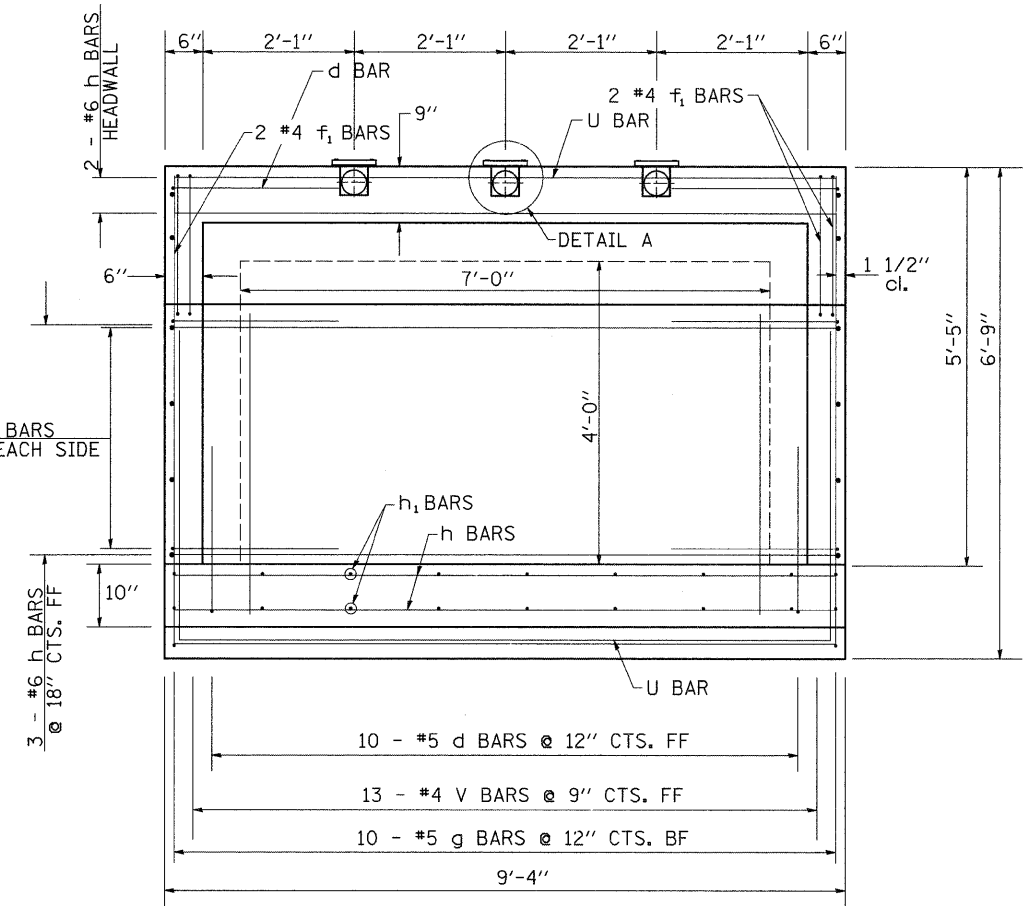

FRONT VIEW

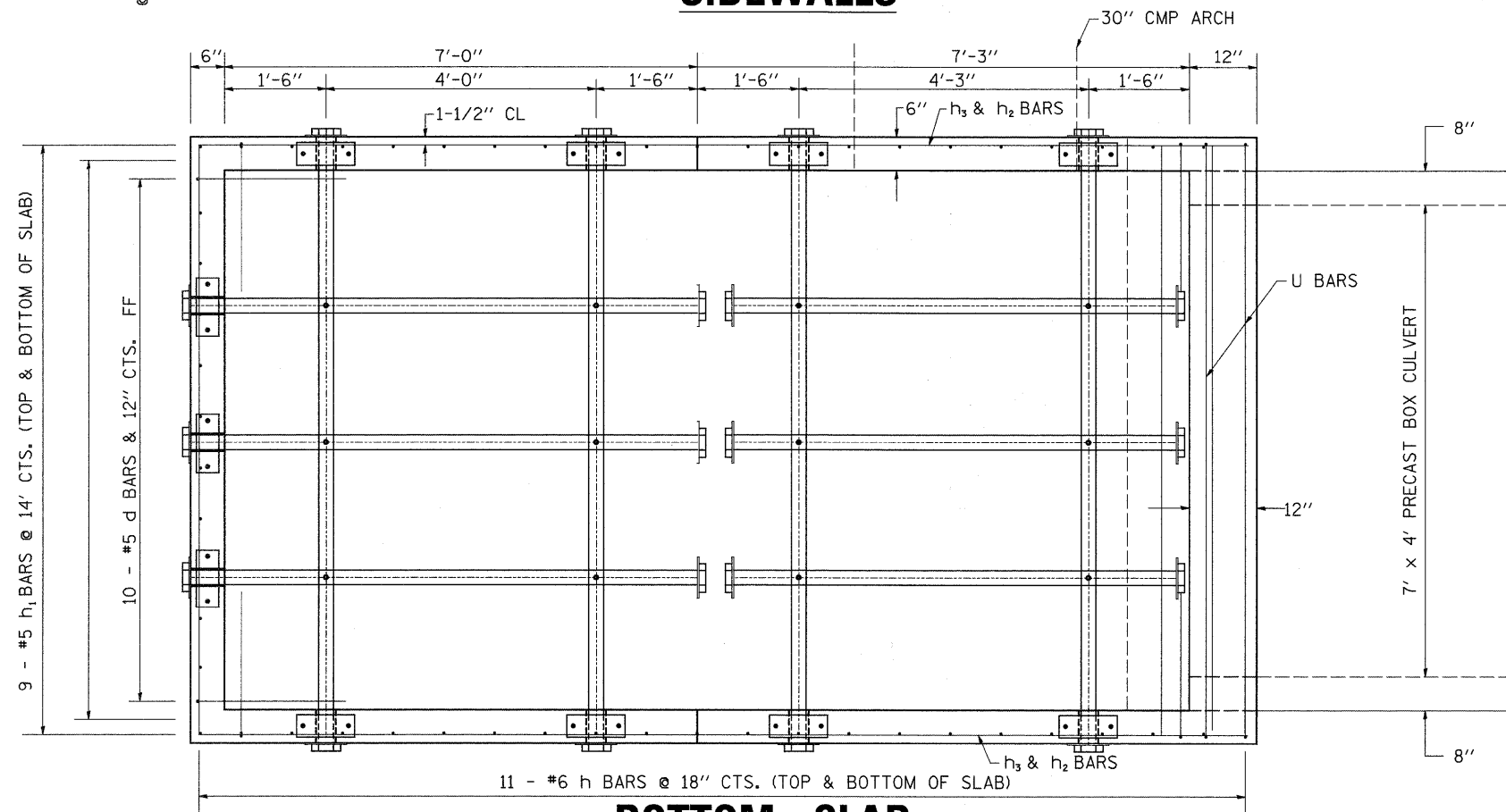

BOTTOM SLAB

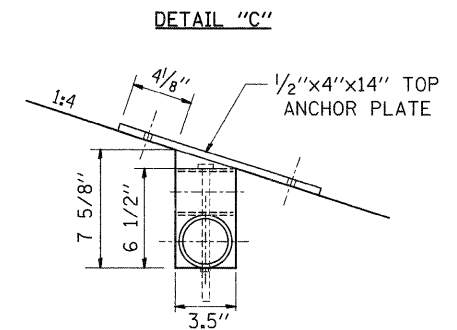
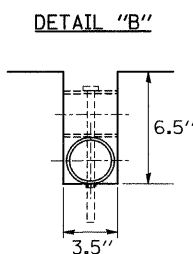
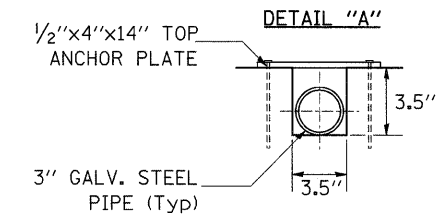

FILE NAME =	USER NAME = cushmanbw	DESIGNED -	REVISED -	STATE OF ILLINOIS DEPARTMENT OF TRANSPORTATION	DROP BOX NO. 2	F.A.P RTE.	SECTION	COUNTY	TOTAL SHEETS	SHEET NO.	
ct:\pw_work\PWIDOT\CUSHMANBW\dms34123\06486culv.dgn	PLOT SCALE = 50.0000' / IN.	DRAWN -	REVISED -			742	37R-3	OGLE	345	198	
PLOT DATE = Fri May 01 08:27:29 2009	DATE -	CHECKED -	REVISED -			CONTRACT NO. 84788					
		DATE -	REVISED -			SCALE:	SHEET NO.	OF	SHEETS	STA.	TO STA.

DROP BOX NO. 2

LT STA 626 + 61

BILL OF MATERIAL

(For Information Only)

BAR	SIZE	NO.	LENGTH	SHAPE
d	5	50	4'-4"	
f	6	2	9'-1"	
f1	4	4	15'-8"	
g	5	10	2'-2"	
h	6	27	9'-1"	
h1	4	18	15'-6"	
h2	5	2	6'-0"	
h3	5	8	15'-6"	
v	4	35	3'-10"	
v1	4	10	9'-11"	
v2	4	8	4'-3"	
u	5	4	18'-1"	
DESCRIPTION			UNIT	QTY
CONCRETE STRUCTURES			CU YD	7.95
REINFORCEMENT BARS			LB	1268
DESCRIPTION			UNIT	QTY.
3" GALVANIZED STEEL PIPE			7'-6"	3
			7'-4"	3
			9'-4"	4
3" GALVANIZED PIPE CAPS			EACH	20
1/4" GALVANIZED STEEL PLATE (9" NOMINAL)			EACH	11
1/2"x4"x14" GALVANIZED STEEL PLATE			EACH	11
5/8"x9" GALVANIZED STEEL BOLTS			EACH	34

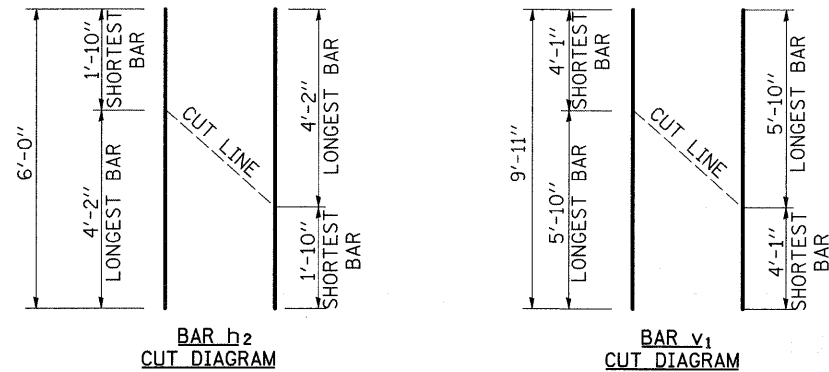

BAR h₂
CUT DIAGRAM

BAR v₁
CUT DIAGRAM

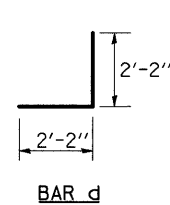

BAR d

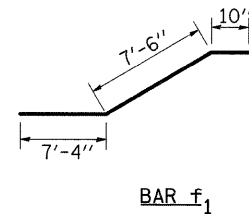

BAR f₁

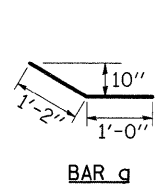

BAR g

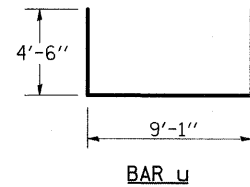

BAR u

GENERAL NOTES:

This work shall be paid for at the contract unit price per Each for Drop Box No. 2.

Contractor shall field verify Galvanized pipe length.

Exposed edges shall be beveled 3/4".

The contract unit price "each" for DROP BOX NO. 2 shall include the Expansion Bolts, Galvanized Pipe, Pipe Caps, Concrete Structures, Reinforcement Bars, Bolts, Nuts, Washers, Steel Plates, earth excavation where required, and necessary grading to fit the inlet as shown in the cross sections or to the slope.

Reinforcement bars shall conform to the requirements of ASTM A 706 Gr. 60 (IL Modified). See Special Provisions.

Steel Plates shall conform to AASHTO M-183 and shall be Galvanized conforming to AASHTO M-111.

Bolts, Nuts, and Washers shall be in accordance with Article 505 of the Standard Specification and shall be galvanized.

See Plan & Profile Sheet for more information.

See Cross Section Sheet for more information.

FILE NAME =	USER NAME = cushmanbw	DESIGNED -	REVISED -	STATE OF ILLINOIS DEPARTMENT OF TRANSPORTATION	DROP BOX NO. 2	F.A.P. RTE.	SECTION	COUNTY	TOTAL SHEETS	SHEET NO.	
cd\pw_work\PWIDOT\CUSHMANBW\dms34123\dms34123.dwg	6486culv.dgn	DRAWN -	REVISED -			742	37R-3	OGLE	345	199	
PLOT SCALE = 50.0000' / IN.	CHECKED -	REVISED -	REVISED -			CONTRACT NO. 84788					
PLOT DATE = Fri May 01 08:27:30 2009	DATE -	REVISED -	REVISED -			SCALE:	SHEET NO.	OF	SHEETS	STA.	TO STA.

DROP BOX NO. 3

LT STA 635 + 63.70

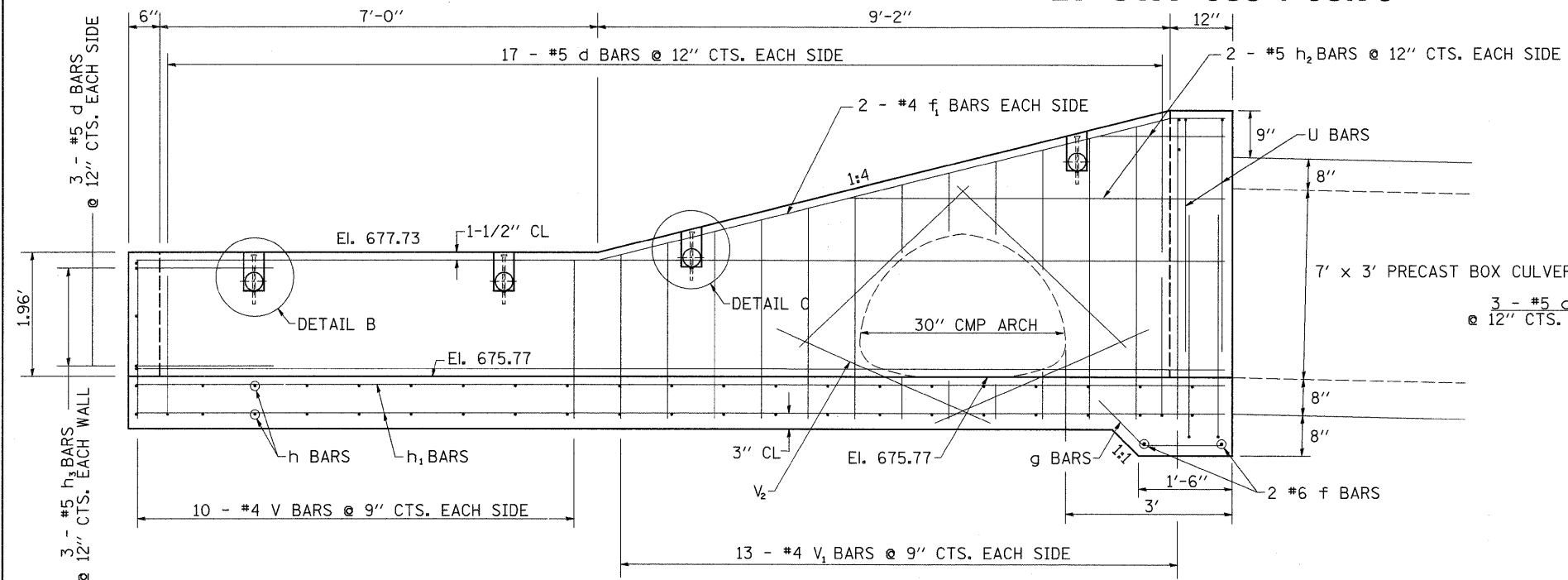

SIDEWALLS

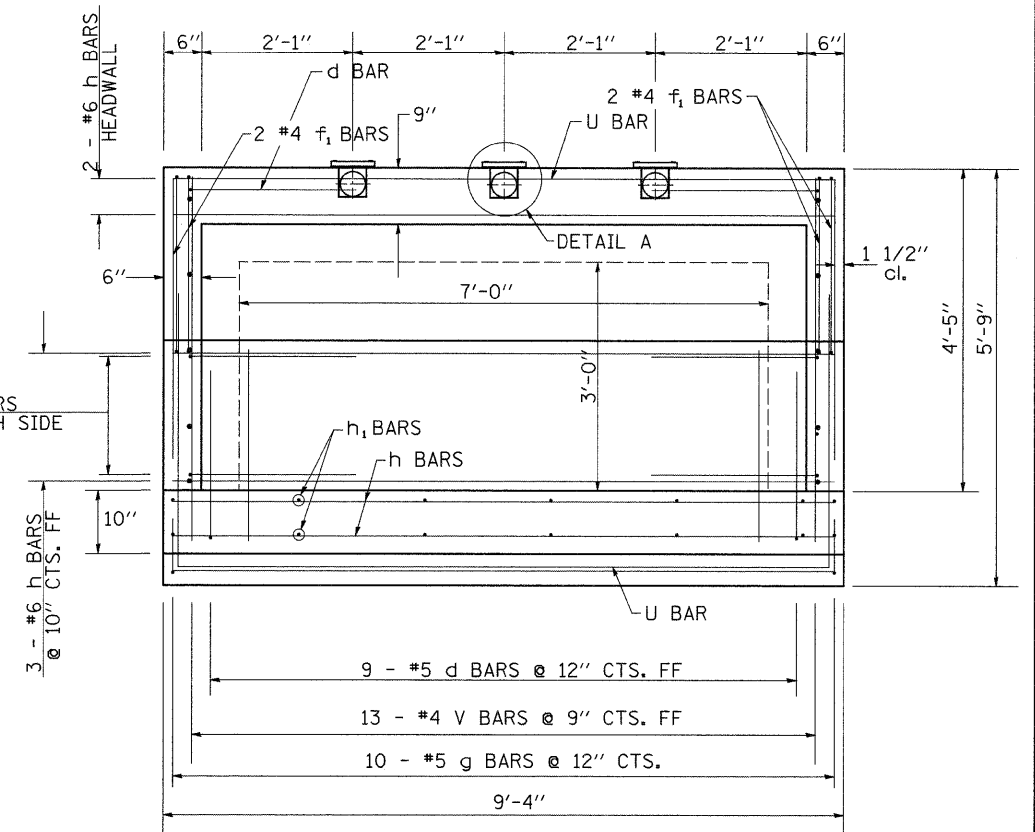

FRONT VIEW

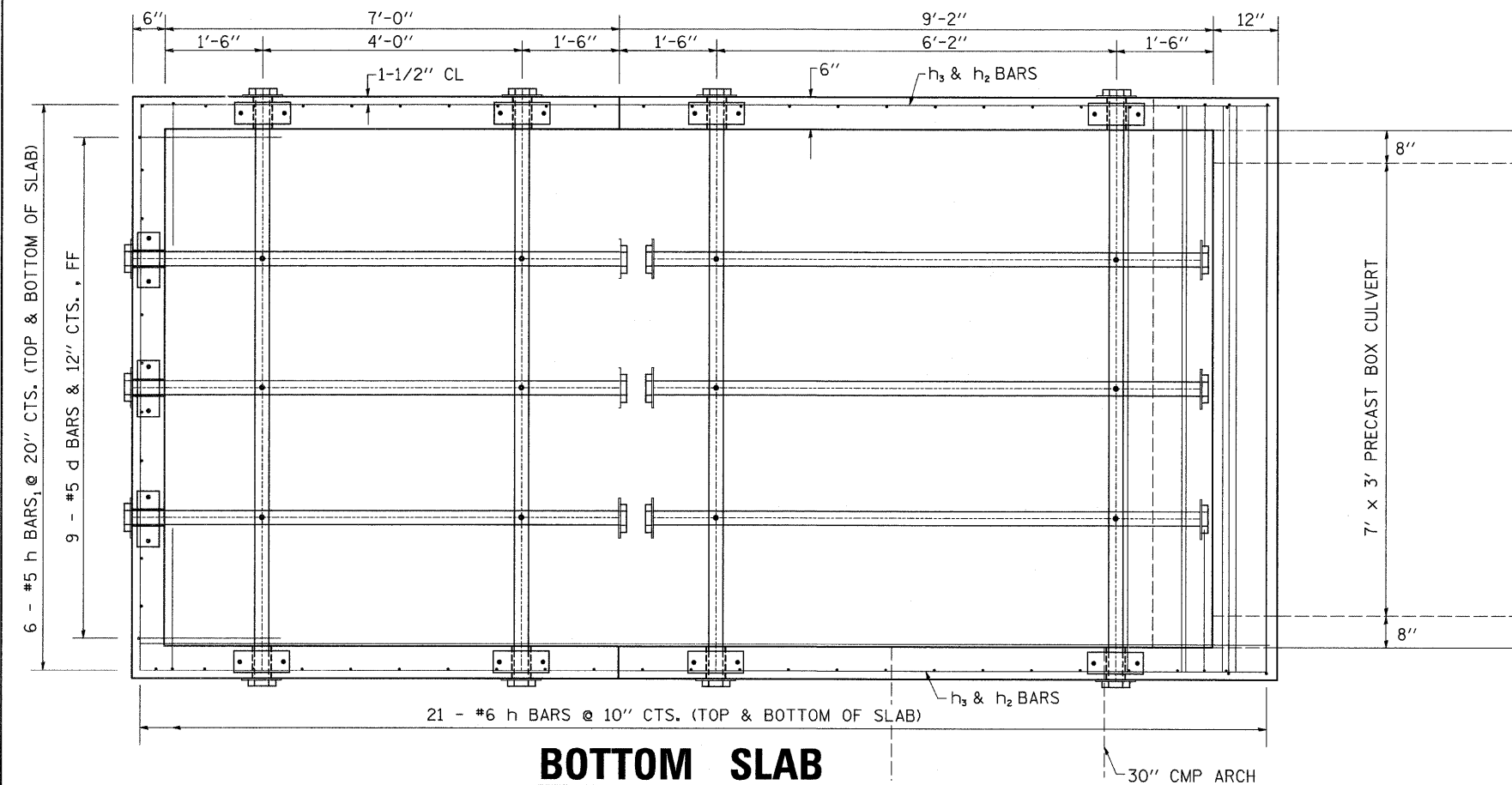

BOTTOM SLAB

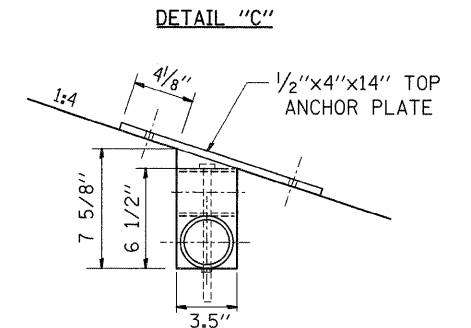
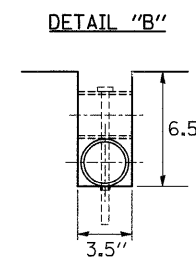
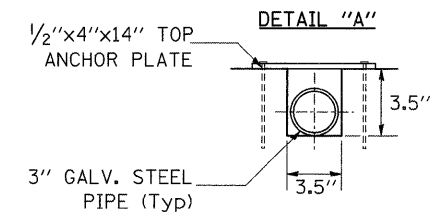

FILE NAME =	USER NAME = cushmanbw	DESIGNED -	REVISED -	STATE OF ILLINOIS DEPARTMENT OF TRANSPORTATION	DROP BOX NO. 3			F.A.P. RTE.	SECTION	COUNTY	TOTAL SHEETS	SHEET NO.
al\pw_work\PWIDOT\CUSHMANBW\dms34123\dms34123.dwg	6486culv.dgn	DRAWN -	REVISED -		742	37R-3	OGLE	345	200	CONTRACT NO. 84788		
	PLOT SCALE = 50.0000' / IN.	CHECKED -	REVISED -							ILLINOIS FED. AID PROJECT		
	PLOT DATE = Fri May 01 08:27:30 2009	DATE -	REVISED -		SCALE:	SHEET NO.	OF	SHEETS	STA.	TO	STA.	