

STATE OF ILLINOIS  
DEPARTMENT OF TRANSPORTATION

ROUTE NO.	SECTION	COUNTY	TOTAL SHEETS	SHEET NO.	SHEET NO. - S-34 S-66 SHEETS
346	*	LAKE	469	203	
FED. ROAD DIST. NO.	ILLINOIS	FED. AID PROJECT	CONTRACT # 60826		
* 125X-HB-(1&2) R-1					

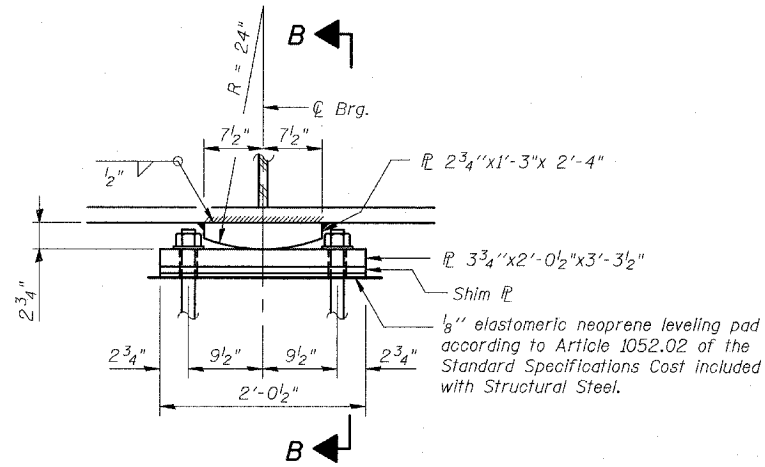

ELEVATION AT PIER

FIXED BEARING

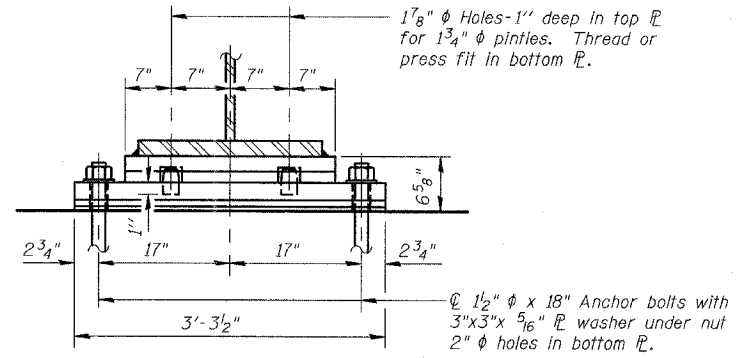

SECTION B-B

Notes:

Anchor bolts shall be ASTM F1554 all-thread (or an Engineer-approved alternative material) of the grade and diameter specified. The corresponding specified grade of AASHTO M314 anchor bolts may be used in lieu of ASTM F1554.

Anchor bolts in fixed bearings may be either cast in place or installed in holes drilled after the supporting member is in place.

Drilled and set anchor bolts shall be installed according to Article 521.06 of the Standard Specifications.

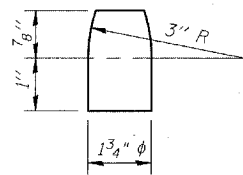

PINTLE

BILL OF MATERIAL

ITEM	UNIT	TOTAL
Anchor Bolts 1 1/2"	Each	40

NOTES

- Structural Steel for the fixed bearing, including pintles, shall be AASHTO M270 Grade 50.
- Two 1/8" adjusting shims shall be provided for each bearing in addition to all other plates or shims and placed as shown on bearing details.

TYLIN INTERNATIONAL

DESIGNED	- MB
CHECKED	- SP
DRAWN	- MAF
CHECKED	- AD

I-2-E1 9-01-03

FIXED BEARING

FAP 346 (U.S. ROUTE 41 - SKOKIE  
HIGHWAY) OVER ILLINOIS ROUTE 132  
SECTION 125X-HB-(1&2)R-1  
LAKE COUNTY  
S.N. 049-0209