

STATE OF ILLINOIS
DEPARTMENT OF TRANSPORTATION

ROUTE NO.	SECTION	COUNTY	TOTAL SHEETS	SHEET NO.	SHEET NO. - 2 2 SHEETS
346	•	LAKE	469	365B	
FED. ROAD DIST. NO.		ILLINOIS	FED. AID PROJECT		
• 125X-HB-(1&2) R-1		CONTRACT # 60826			

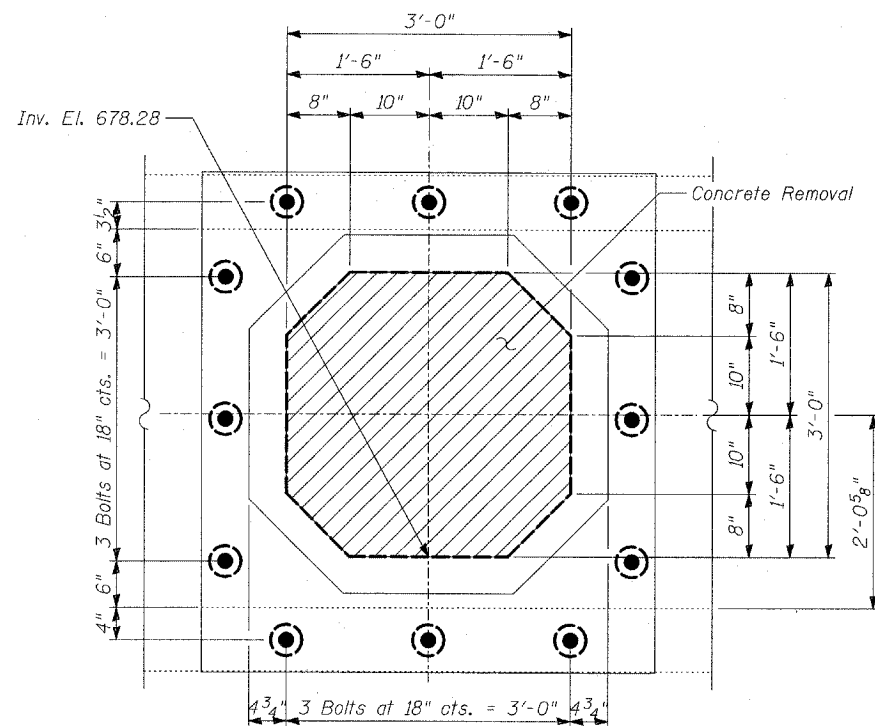

**CONCRETE REMOVAL & EXPANSION BOLTS
LAYOUT - ELEVATION**

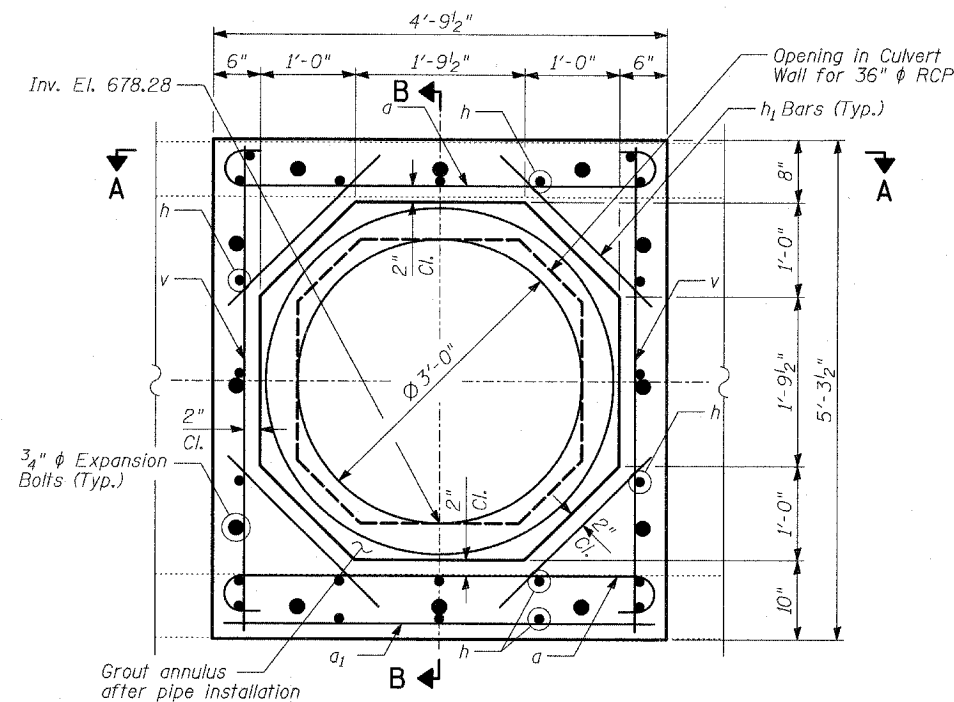

COLLAR DETAIL - ELEVATION

BILL OF MATERIAL

Bar	Number	Size	Length	Shape
a	6	#5	5'-8"	
a1	3	#4	4'-6"	
h	23	#5	1'-3"	
h1	12	#5	2'-3"	
v	6	#4	5'-0"	
Reinforcement Bars		POUND	130	
Porous Granular Embankment		CU YD	17	
Concrete Removal		CU YD	1	
Structure Excavation		CU YD	8	
Concrete Box Culverts		CU YD	1	
3/4" φ Expansion Bolts		EACH	12	

NOTES:

Expansion bolts shall be 3/4" φ hooked bolts. Hooked bolts shall extend a minimum of 9" into new concrete.

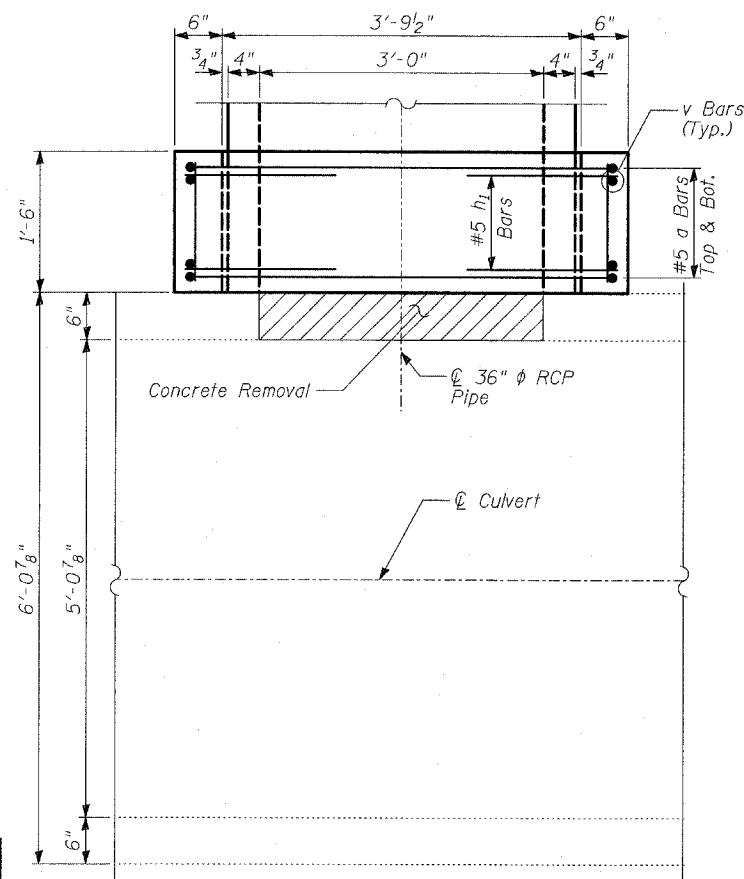

SECTION A-A
(Expansion Bolts Not Shown for Clarity)

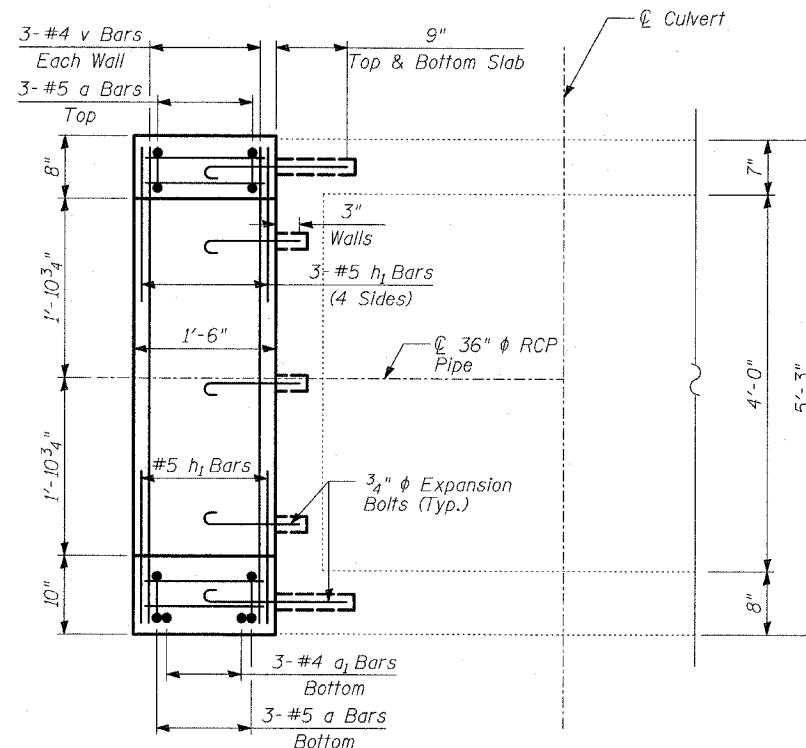

SECTION B-B

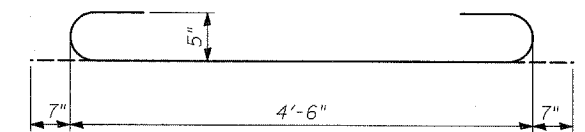

BAR a

TYLIN INTERNATIONAL

DESIGNED	-
CHECKED	-
DRAWN	-
CHECKED	-

PIPE COLLAR AT EXISTING CULVERT
REINFORCEMENT DETAILS
STA. 547+15.48

FAP 346 (U.S. ROUTE 41 - SKOKIE
HIGHWAY) OVER ILLINOIS ROUTE 132
SECTION 125X-HB-(1&2)R-1
LAKE COUNTY