

When "A" is 3'-6" or less, the temporary concrete barrier shall be anchored to the new slab according to Detail I or Detail II. No anchorage is required when "A" is greater than 3'-6".

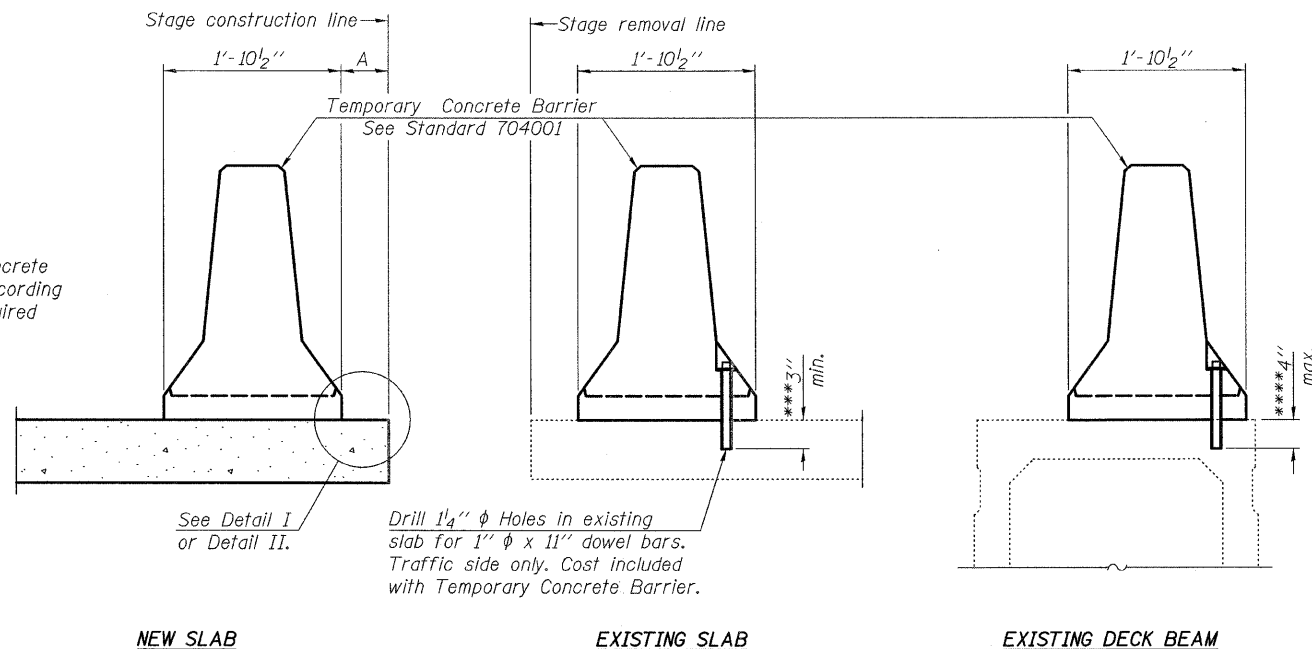

Drill 1 1/4"  $\phi$  Holes in existing slab for 1"  $\phi$  x 11" dowel bars. Traffic side only. Cost included with Temporary Concrete Barrier.

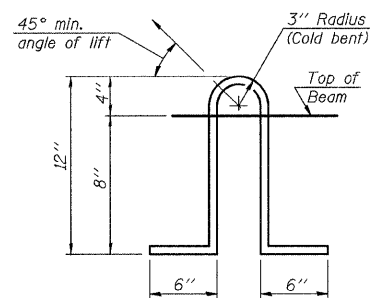

LIFTING LOOP DETAIL

**NOTES**

Detail I - With Bar Splicer or Couplers:  
Connect one (1) 1"x7"x10" steel  $\bar{P}$  to the top layer of couplers with 2-5/8"  $\phi$  bolts screwed to coupler at approximate  $\bar{C}$  of each barrier panel.

Detail II - With Extended Reinforcement Bars:  
Connect one (1) 1"x7"x10" steel  $\bar{P}$  to the concrete slab or concrete wearing surface with 2-5/8"  $\phi$  Expansion Anchors or cast in place inserts spaced between the top layer of reinforcement at approximate  $\bar{C}$  of each barrier panel.

Cost of anchorage is included with Temporary Concrete Barrier. The 1" x 7" x 10" plate shall not be removed until stage II construction forms and all reinforcement bars are in place and the concrete is ready to be placed.

**SECTIONS THRU SLAB OR DECK BEAM**

\*\*\*Dimension shown is minimum required embedment into concrete. If hot-mix asphalt wearing surface is present, minimum embedment shall be in addition to wearing surface depth.

\*\*\*\*If existing deck beam is to remain in place after stage construction, embedment shall only be into wearing surface and not into existing deck beam concrete.

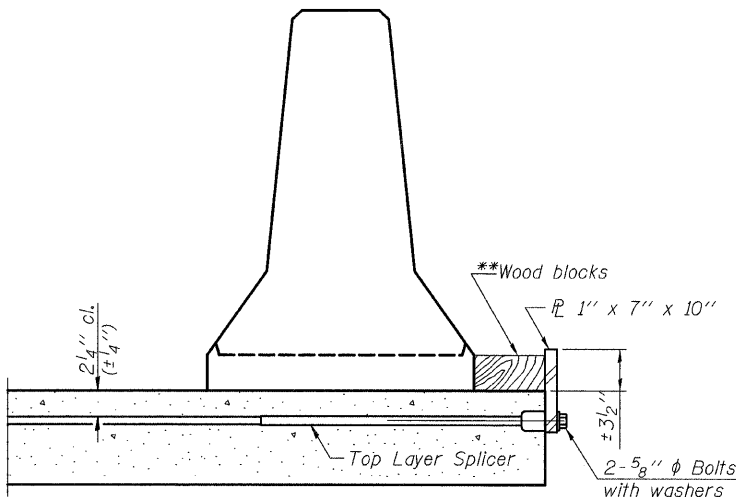

DETAIL I

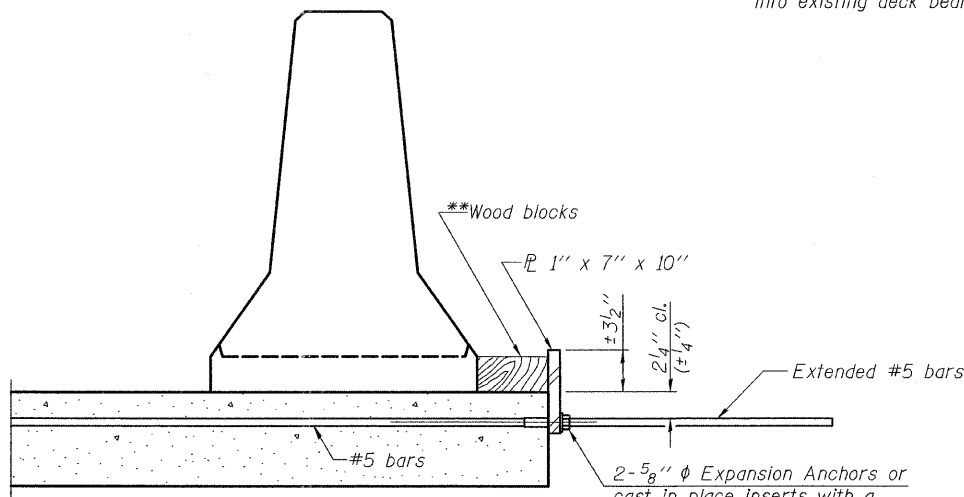

DETAIL II

\*\*Wood blocks may be omitted when required to provide minimum stage traffic lane width. When the wood blocks are omitted, the concrete barrier shall be in direct contact with the steel retainer plate.

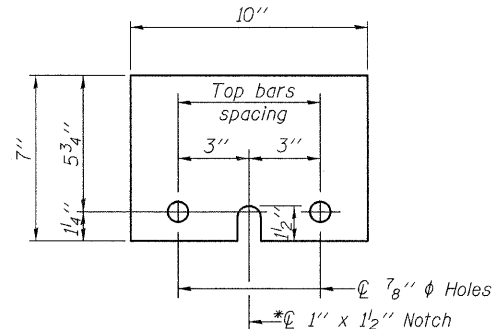

STEEL RETAINER  $\bar{P}$  1" x 7" x 10"

\* Required only with Detail II

R-27

FILE NAME = temp cono barrier.sht	USER NAME = IDOT	DESIGNED - B.N.S.	REVISED -	<b>STATE OF ILLINOIS DEPARTMENT OF TRANSPORTATION</b>	<b>TEMPORARY CONCRETE BARRIER FOR STAGE CONSTRUCTION HIGGINS ROAD (IL. RTE. 72) OVER SALT CREEK S.N. 016-0504</b>	F.A.P. RTE. 559/341	SECTION 2008-007 B	COUNTY COOK	TOTAL SHEETS 39	SHEET NO. 35	
PLOT SCALE = 1:8000' / IN.	CHECKED - B.N.S. / J.C.N.	REVISED -	SCALE: NONE			SHEET NO. 512 OF 512 SHEETS	STA. TO STA.	FED. ROAD DIST. NO.	ILLINOIS FED. AID PROJECT	CONTRACT NO. 60D55	
PLOT DATE = 4/30/2008	DATE - APRIL 21, 2008	REVISED -									

CHRISTIAN-ROGE & ASSOCIATES, INC.  
ENGINEERS / PLANNERS / SURVEYORS  
211 W. WACKER DRIVE CHICAGO, IL. 60606  
PHONE: (312)372-2023 FAX: (312)372-5274