



F.A. RTE.	SECTION	COUNTY	TOTAL SHEETS	SHEET NO.
N/A	D6-00017-00-PV	KANE	232	125
STA.		TO STA.		
FED. ROAD DIST. NO. _		ILLINOIS	FED. AID PROJECT	

**TEMPORARY CABLE PLAN**  
**STAGE 3**  
N.T.S.



**TEMPORARY CABLE DIAGRAM LEGEND**

- R TEMPORARY TRAFFIC SIGNAL SECTION OR PEDESTRIAN SIGNAL SECTION 12" (300mm)
- X TEMPORARY CONTROLLER CABINET
- MC TEMPORARY MASTER CONTROLLER
- + TEMPORARY SERVICE INSTALLATION
- 5 INDICATES NUMBER OF CONDUCTORS IN CABLE. ALL CONDUCTORS TO BE NUMBER 14 AWG WIRE UNLESS OTHERWISE NOTED.
- 24 TEMPORARY INTERCONNECT CABLE NO 62.5/1250 MM 12F AND SM 12F FIBER OPTIC CABLE
- EMERGENCY VEHICLE DETECTOR
- CONFIRMATION BEACON
- VEHICLE DETECTOR, INDUCTION LOOP
- PEDESTRIAN PUSHBUTTON DETECTOR
- 12" (300mm) PEDESTRIAN SIGNAL SECTION
- VIDEO VEHICLE SENSOR
- T TELEPHONE CONNECTION

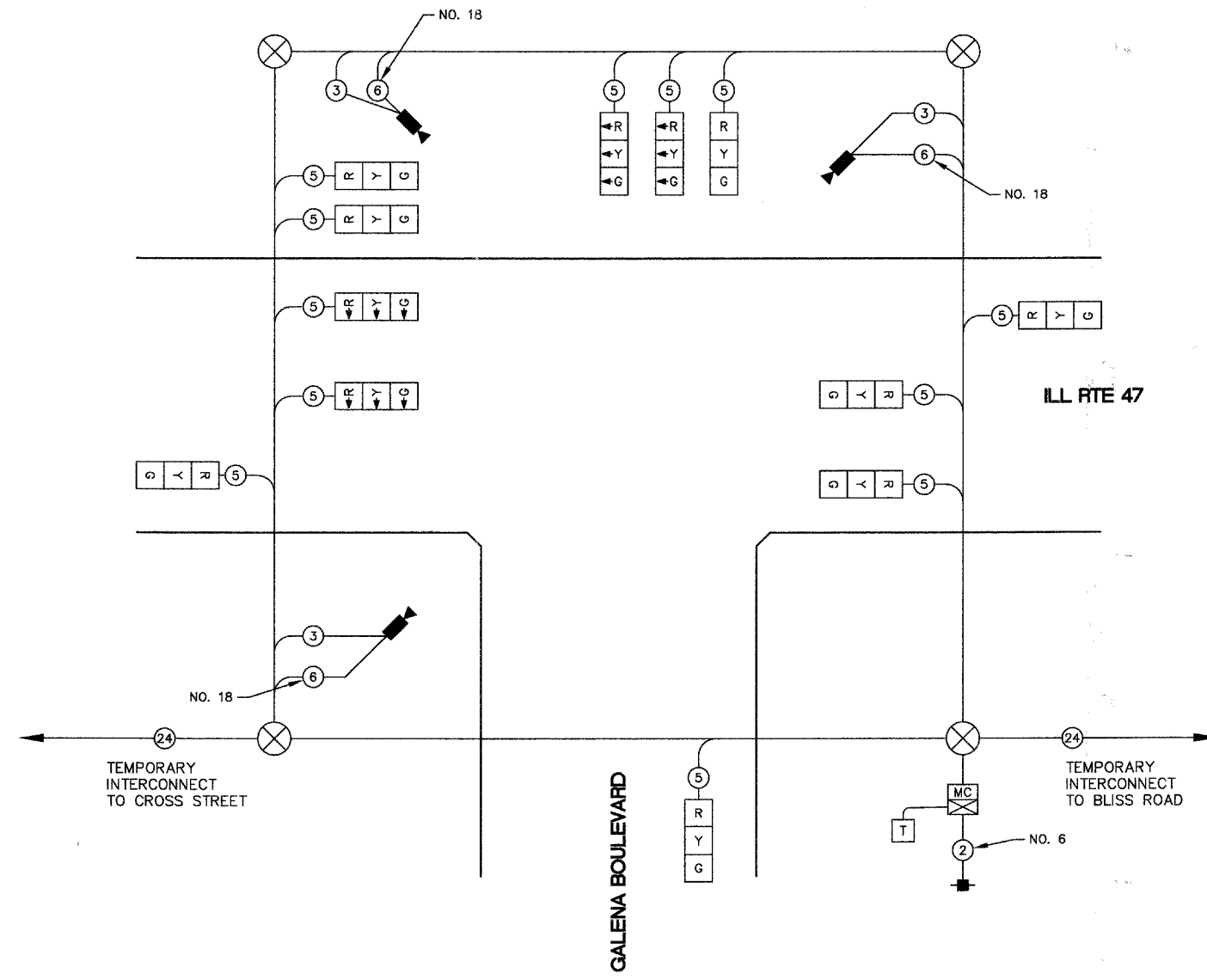

**TEMPORARY CONTROLLER SEQUENCE**  
**STAGE 3**

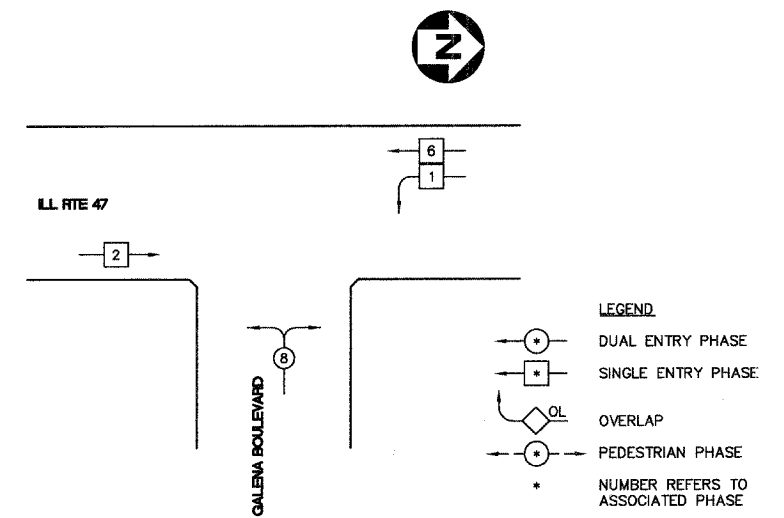

**TEMPORARY PHASE DESIGNATION DIAGRAM**

I.D.O.T. TRAFFIC SIGNAL INSTALLATION ELECTRICAL SERVICE REQUIREMENTS					TOTAL WATTAGE
TYPE	NO. LAMPS	INCAND.	LED	% OPERATIONS	
SIGNAL (RED)	12		10	0.50	60.00
(YELLOW)	12		19	0.25	57.00
(GREEN)	12		11	0.25	33.00
ARROW	-		10	0.10	-
PED. SIGNAL	-		7	1.00	-
CONTROLLER	1		100	1.00	100.00
ILLUM. SIGN	-		-	0.05	-
FLASHER				0.50	-
TOTAL =					250.00

ENERGY COST - BILLED TO: VILLAGE OF SUGAR GROVE  
10 MUNICIPAL DRIVE  
SUGAR GROVE, IL 60554

ENERGY SUPPLY - CONTACT: MARK SCHERIBEL  
PHONE: 630-862-5160  
COMPANY: COMED

REVISIONS	
NAME	DATE

ILLINOIS DEPARTMENT OF TRANSPORTATION

**ILL RTE 47 AND GALENA BOULEVARD TEMPORARY SIGNAL CABLE PLAN, PHASE DESIGNATION DIAGRAM (STAGE 3)**

SCALE: NTS  
DATE: 05/16/08

DRAWN BY: KKP  
CHECKED BY: TWV

PLAN	DATE
REVISIONS	BY
NO. 1	
NO. 2	
NO. 3	
NO. 4	
NO. 5	
NO. 6	
NO. 7	
NO. 8	
NO. 9	
NO. 10	
NO. 11	
NO. 12	
NO. 13	
NO. 14	
NO. 15	
NO. 16	
NO. 17	
NO. 18	
NO. 19	
NO. 20	
NO. 21	
NO. 22	
NO. 23	
NO. 24	
NO. 25	
NO. 26	
NO. 27	
NO. 28	
NO. 29	
NO. 30	

PROFILE	DATE
REVISIONS	BY
NO. 1	
NO. 2	
NO. 3	
NO. 4	
NO. 5	
NO. 6	
NO. 7	
NO. 8	
NO. 9	
NO. 10	
NO. 11	
NO. 12	
NO. 13	
NO. 14	
NO. 15	
NO. 16	
NO. 17	
NO. 18	
NO. 19	
NO. 20	
NO. 21	
NO. 22	
NO. 23	
NO. 24	
NO. 25	
NO. 26	
NO. 27	
NO. 28	
NO. 29	
NO. 30	