

STATE OF ILLINOIS  
DEPARTMENT OF TRANSPORTATION

ROUTE NO.	SECTION	COUNTY	SHEETS	SHEET	SHEET NO. 13
FAP 869	105BR-1	SALINE	118	35	18 SHEETS
FED. ROAD DIST. NO. 1	ILLINOIS	FED. AID PROJECT - AID			

78031

**GENERAL NOTES**

The strip seal shall be made continuous and shall have a minimum thickness of 1/4". The configuration of the strip seal shall match the configuration of the Locking Edge Rails.

The height and thickness of the Locking Edge Rails shown are minimum dimensions. The actual configuration of the Locking Edge Rails and matching strip seal may vary from manufacturer to manufacturer. Flanged edge rails will not be allowed.

Locking Edge Rails may be spliced at slope discontinuities and stage construction joints.

The manufacturer's recommended installation methods shall be followed.

All steel components shall be galvanized after fabrication according to Article 520.03 of the Standard Specifications.

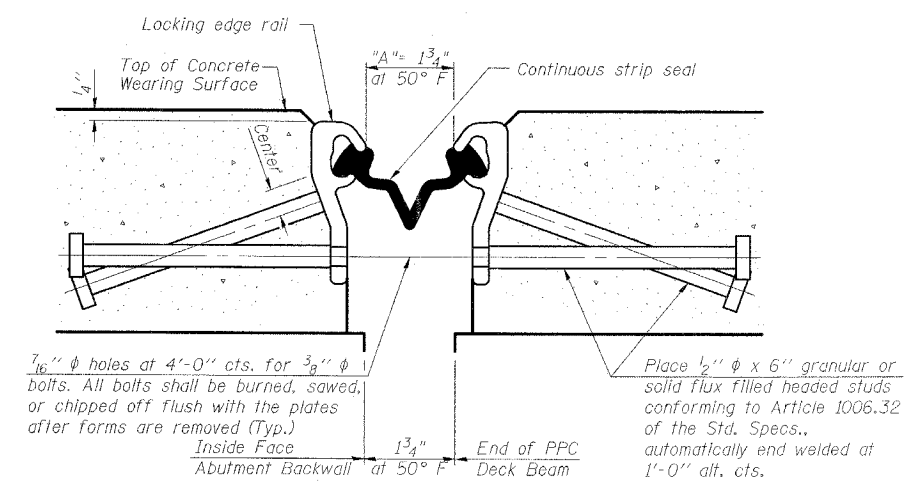

**SECTION THRU STRIP SEAL JOINT  
FOR OVERLAY OVER DECK BEAMS**

**BILL OF MATERIAL**

Item	Unit	Quantity
Preformed Joint Strip Seal	Foot	39

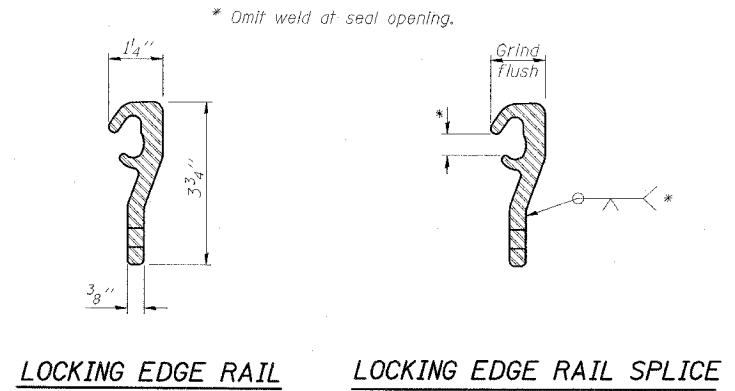

**ESCA**  
CONSULTANTS, INC.

DESIGNED BY:	JMS	02/08
DRAWN BY:	HAS	02/08
CHECKED BY:	ELH	02/08
APPROVED BY:	RDP	02/08

**STRIP SEAL EXPANSION JOINT  
IL 34 OVER  
MIDDLE FORK SALINE RIVER OVERFLOW  
FAP ROUTE 869 - SECTION 105BR-1  
SALINE COUNTY  
STATION 1542+00.00  
STRUCTURE NO. 083-0037**