

STATE OF ILLINOIS
DEPARTMENT OF TRANSPORTATION

ROUTE NO.	SECTION	COUNTY	SHEET	SHEET NO.
FAP 869	105BR-2	SALINE	118	58
FED. ROAD DIST. NO. 118				23 SHEETS
ILLINOIS FED. AID PROJECT - A10				

78031

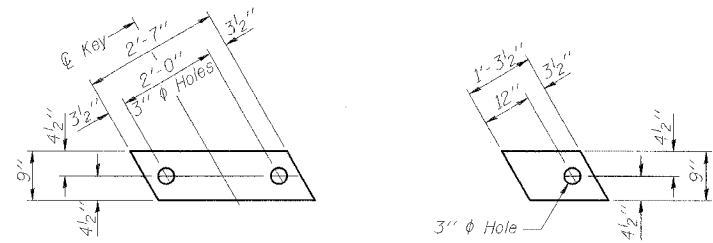

FABRIC BEARING PAD
(Interior)

FABRIC BEARING PAD
(Exterior)

FIXED

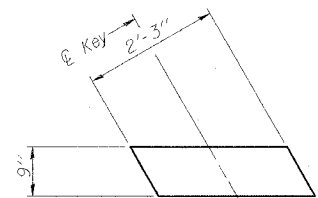

FABRIC BEARING PAD
(Interior)

FABRIC BEARING PAD
(Exterior)

EXPANSION

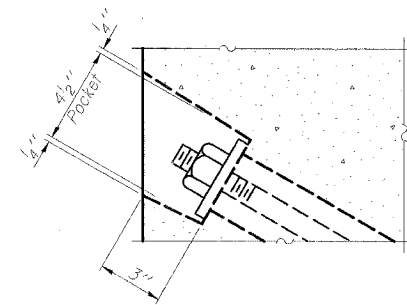

SECTION A-A

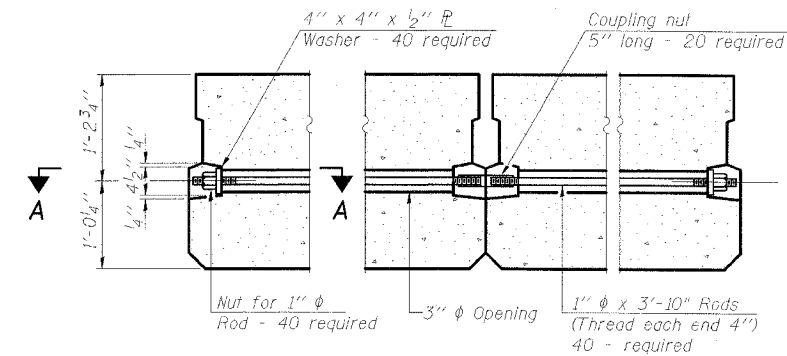

TYPICAL TRANSVERSE TIE ASSEMBLY

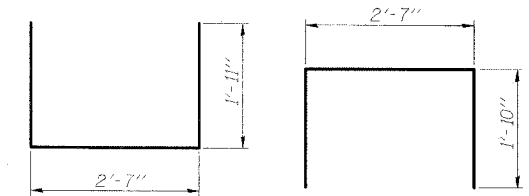

BAR S(E)

BAR S1(E)

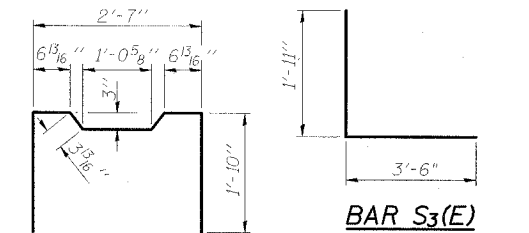

BAR S2(E)

BAR S3(E)

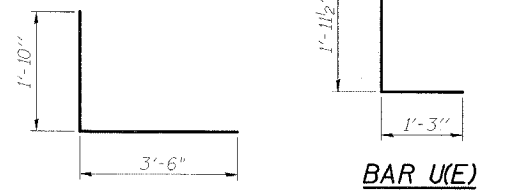

BAR S4(E)

BAR U(E)

BAR U1(E)

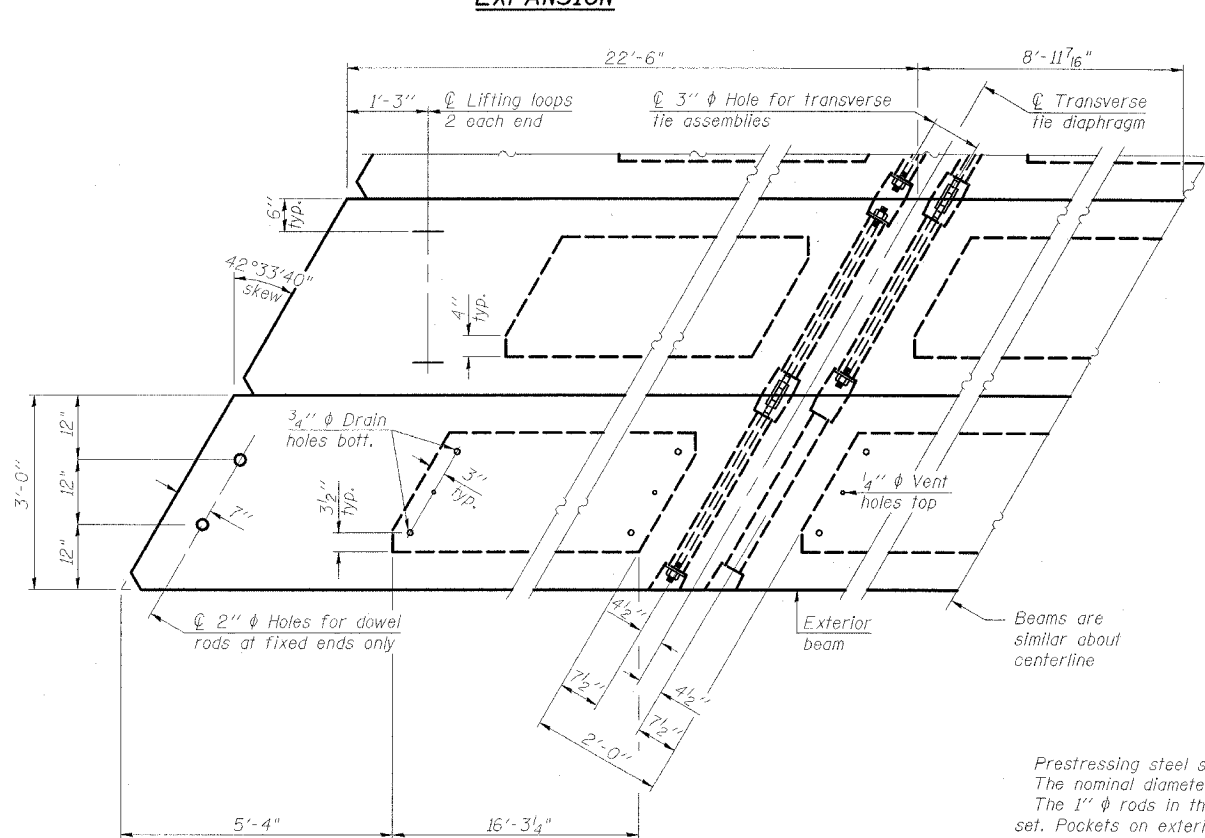

PLAN VIEW

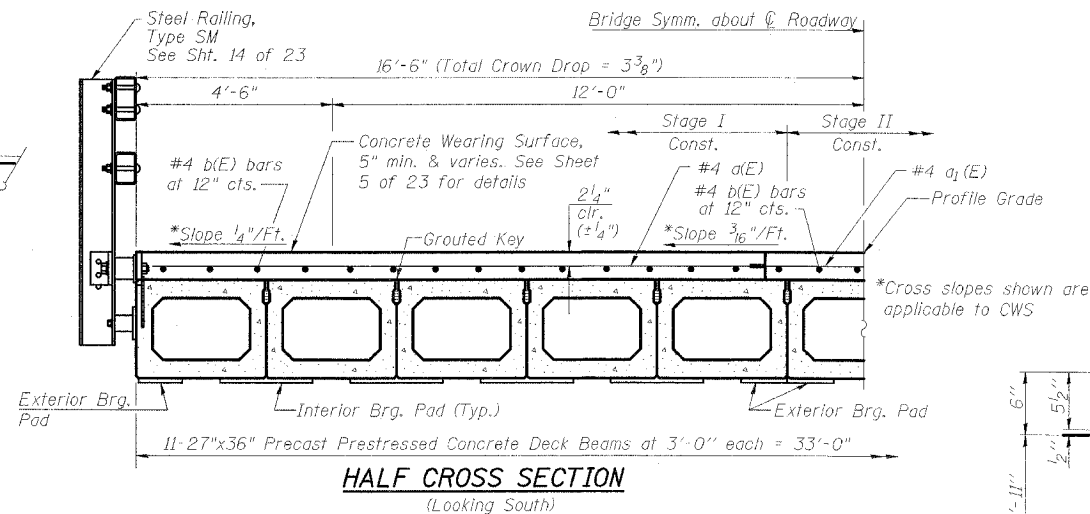

HALF CROSS SECTION
(Looking South)

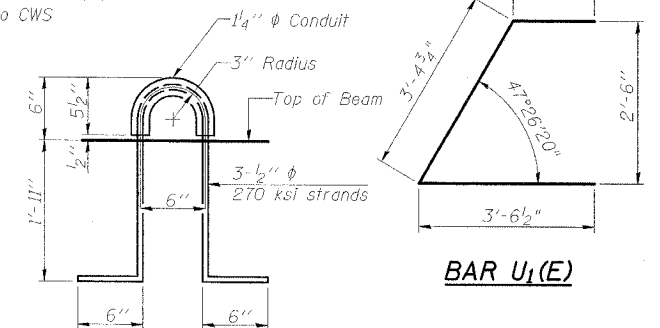

LIFTING LOOP DETAIL

BILL OF MATERIAL

Item	Unit	Quantity
Precast Prestressed Conc. Deck Bms. (27" Depth)	Sq. Ft.	2076

SUPERSTRUCTURE DETAILS - SPAN 2

IL 34 OVER

MIDDLE FORK SALINE RIVER
FAP ROUTE 869 - SECTION 105BR-2

SALINE COUNTY

STATION 1561+70.00

STRUCTURE NO. 083-0038

NOTES

- Prestressing steel shall be uncoated high strength, low relaxation 7-wire strand, Grade 270. The nominal diameter shall be 1/2" and the nominal cross-sectional area shall be 0.153 sq. in. The 1" rods in the transverse tie assembly shall be tightened to a snug fit and the threads set. Pockets on exterior faces of bridge shall be filled with grout after transverse tie assembly is in place.
- Reinforcement bars shall conform to ASTM A 706 (IL MOD), Grade 60. (See Special Provisions)
- Two 1/8" fabric adjusting shims of the dimensions of the exterior bearing pad shall be provided for each bearing pad location.
- A minimum 2 1/2" diameter lifting pin shall be used to engage the lifting loops during handling.
- Corrosion Inhibitor, per Article 1020.05(b)(12) and 1021.06 of the Standard Specifications, shall be used in the concrete for precast prestressed concrete deck beams.
- Compressive strength of prestressed concrete, f'c, shall be 6000 psi.
- Compressive strength of prestressed concrete at release, f'ci, shall be 5000 psi.
- See Sht. No. 2 of 23 for location of rail anchors and additional notes.

Note: Connect beams in pairs with the transverse tie configuration shown.

ESCA
CONSULTANTS, INC.

DESIGNED BY:	JMS	02/08
DRAWN BY:	HAS	02/08
CHECKED BY:	ELH	04/08
APPROVED BY:	RDP	04/08