

CONTRACTOR SHALL MILL BEFORE PATCHING

HOT-MIX ASPHALT MIXTURE REQUIREMENTS	
MIXTURE TYPE	AIR VOIDS @ 100psi
PAVEMENT RESURFACING (US 14)	
POLYMERIZED HOT-MIX ASPHALT SURFACE COURSE, MIX "F", N90 (IL 9.5 mm) (1 3/4")	4% @ 90 Gyr.
POLYMERIZED LEVELING BINDER (MACHINE METHOD), IL-4.75, N50 (3/4")	3.5% @ 50 Gyr.
PAVEMENT WIDENING (US 14)	
POLYMERIZED HOT-MIX ASPHALT SURFACE COURSE, MIX "F", N90 (IL 9.5 mm) (1 3/4")	4% @ 90 Gyr.
POLYMERIZED LEVELING BINDER (MACHINE METHOD), IL-4.75, N50 (3/4")	3.5% @ 50 Gyr.
HOT-MIX ASPHALT BINDER COURSE, IL-19.0, N90 (2 1/4")	4% @ 90 Gyr.
HOT-MIX ASPHALT BASE COURSE WIDENING, 9/4" (HMA BINDER IL-19, N90)	4% @ 90 Gyr.
FULL-DEPTH PAVEMENT RECONSTRUCTION (LUCAS RD, COLLEGE ENTR 3) - SEE NOTE 7	
HOT-MIX ASPHALT SURFACE COURSE, MIX "D", N70 (IL 9.5 mm) (1 1/2")	4% @ 70 Gyr.
HOT-MIX ASPHALT BINDER COURSE, IL-19.0, N70 (1 7/8")	4% @ 70 Gyr.
PAVEMENT RESURFACING (LUCAS RD, COLLEGE ENTRANCE 1)	
HOT-MIX ASPHALT SURFACE COURSE, MIX "D", N70 (IL 9.5 mm) (1 1/2")	4% @ 70 Gyr.
POLYMERIZED LEVELING BINDER (MACHINE METHOD), IL-4.75, N50 (3/4")	3.5% @ 50 Gyr.
PAVEMENT WIDENING (LUCAS RD, COLLEGE ENTRANCE 3) - SEE NOTE 8	
HOT-MIX ASPHALT SURFACE COURSE, MIX "D", N70 (IL 9.5 mm) (1 1/2")	4% @ 70 Gyr.
POLYMERIZED LEVELING BINDER (MACHINE METHOD), IL-4.75, N50 (3/4")	3.5% @ 50 Gyr.
HOT-MIX ASPHALT BINDER COURSE, IL-19.0, N70 (2 1/4")	4% @ 70 Gyr.
HOT-MIX ASPHALT BASE COURSE WIDENING, 4 1/2" (HMA BINDER IL-19)	4% @ 70 Gyr.
FULL-DEPTH PAVEMENT RECONSTRUCTION (RIDGEFIELD ROAD SOUTH) - SEE NOTE 7	
HOT-MIX ASPHALT SURFACE COURSE, MIX "D", N70 (IL 9.5 mm) (1 1/2")	4% @ 70 Gyr.
HOT-MIX ASPHALT BINDER COURSE, IL-19.0, N70 (1 7/8")	4% @ 70 Gyr.
SHOULDER RECONSTRUCTION (RIDGEFIELD ROAD SOUTH)	
HOT-MIX ASPHALT SHOULDERS, 9" (HMA BINDER IL-19)	4% @ 50 Gyr.
PAVEMENT RESURFACING (RIDGEFIELD ROAD SOUTH)	
HOT-MIX ASPHALT SURFACE COURSE, MIX "D", N70 (IL 9.5 mm) (1 1/2")	4% @ 70 Gyr.
POLYMERIZED LEVELING BINDER (MACHINE METHOD), IL-4.75, N50 (3/4")	3.5% @ 50 Gyr.
HOT-MIX ASPHALT BINDER COURSE, IL-19.0, N70 (2 1/4")	4% @ 70 Gyr.
HOT-MIX ASPHALT BASE COURSE WIDENING, 4 1/2" (HMA BINDER IL-19)	4% @ 70 Gyr.
FULL-DEPTH PAVEMENT RECONSTRUCTION (LENNY DR) - SEE NOTE 7	
HOT-MIX ASPHALT SURFACE COURSE, MIX "D", N70 (IL 9.5 mm) (1 1/2")	4% @ 70 Gyr.
HOT-MIX ASPHALT BINDER COURSE, IL-19.0, N70 (1 7/8")	4% @ 70 Gyr.
STABILIZED SUBBASE (US 14, RIDGEFIELD ROAD SOUTH, IL 176, LENNY DRIVE)	
STABILIZED SUBBASE - HOT-MIX ASPHALT, 4 1/2" (HMA BINDER IL-19 mm)	3% @ 50 Gyr.
DRIVEWAYS (PRIVATE /COMMERCIAL)	
HOT-MIX ASPHALT SURFACE COURSE, MIX "D", N50; 2" (IL 9.5 mm)	4% @ 50 Gyr.
HOT-MIX ASPHALT BASE COURSE (HMA BINDER IL-19; PE -6", CE -8")	4% @ 50 Gyr.
DRIVEWAYS (FIELD ENTRANCE)	
HOT-MIX ASPHALT SURFACE COURSE, MIX "D", N50; 2" (IL 9.5 mm)	4% @ 50 Gyr.
TEMPORARY PAVEMENT	
HOT-MIX ASPHALT SURFACE COURSE, MIX "D", N50 2" (IL 9.5 mm)	4% @ 50 Gyr.
TEMPORARY PAVEMENT (HMA BINDER IL-19mm) (8 1/4")	4% @ 50 Gyr.
PAVEMENT PATCHING	
CLASS "D" PATCHES (HMA BINDER IL-19 mm) (6", 9", 13", 15", 16", 17")	4% @ 70 Gyr.
MULTI-USE TRAIL	
HOT-MIX ASPHALT SURFACE COURSE, MIX "D", N50 (IL 9.5 mm) (1 1/2")	4% @ 50 Gyr.
HOT-MIX ASPHALT BINDER COURSE, IL-19.0, N50 (2 1/2")	4% @ 50 Gyr.

THE UNIT WEIGHT USED TO CALCULATE ALL HOT-MIX ASPHALT SURFACE MIXTURE QUANTITIES IS 132 LBS/SO YO/IN. THE "AC TYPE" FOR POLYMERIZED HMA MIXES SHALL BE "SBS/SBR PG 76-22" AND FOR NON-POLYMERIZED HMA THE "AC TYPE" SHALL BE "PG 64-22" UNLESS MODIFIED BY DISTRICT ONE SPECIAL PROVISIONS. FOR "PERCENT OF RAP" SEE DISTRICT ONE SPECIAL PROVISIONS.

NOTES:

- UNLESS OTHERWISE NOTED, USE U.S. ROUTE 14 PAVEMENT FOR SIDEROADS.
- POROUS GRANULAR EMBANKMENT SUBGRADE (PGES) HAS BEEN PROVIDED FOR USE AT LOCATIONS OF UNSUITABLE SOILS AS SHOWN IN SCHEDULE OF QUANTITIES.
- BIKETRAIL STRUCTURE; AGGREGATE BASE COURSE, TYPE B 10" HOT-MIX ASPHALT BINDER COURSE, IL-19.0, N50 2 1/2"; HOT-MIX ASPHALT SURFACE COURSE, MIX "D", N50 (IL 9.5 mm) 1 1/2".
- CONCRETE MEDIAN IS BEING SHOWN. SEE LANDSCAPING PLANS FOR LANDSCAPED / CONCRETE MEDIAN LIMITS. SEE LANDSCAPED MEDIAN DETAIL ON SHEETS 12 AND 13.
- PCC TEMPORARY PAVEMENT SHALL CONSIST OF CLASS PV CONCRETE MEETING THE REQUIREMENTS OF ART. 1020 OF THE STANDARD SPECIFICATIONS; TYPICALLY 10".
- PROPOSED TOPSOIL, 6" WILL CONSIST OF EXISTING TOPSOIL AND PAID FOR AS 'TOPSOIL EXCAVATION AND PLACEMENT' FOR THE AMOUNT OF SUITABLE TOPSOIL AVAILABLE. ALL ADDITIONAL TOPSOIL NEEDED WILL BE PAID FOR AS 'TOPSOIL FURNISH AND PLACE, 6" '.
- LUCAS RD, COLLEGE ENTR 3, RIDGEFIELD ROAD SOUTH AND LENNY DR FULL-DEPTH PAVEMENT RECONSTRUCTION WILL BE PAID FOR AS "HOT-MIX ASPHALT PAVEMENT (FULL-DEPTH), 9 INCH".
- "HOT-MIX ASPHALT BINDER COURSE, IL-19.0, N70 2 1/4 INCH" AND "HOT-MIX ASPHALT BASE COURSE WIDENING, 4 1/2" (HMA BINDER IL-19)" WILL BE PAID FOR AS "HOT-MIX ASPHALT BASE COURSE WIDENING, 6 3/4" (HMA BINDER IL-19)".
- MULTI-USE PATH SHALL BE COMPLIANT WITH THE AMERICAN WITH DISABILITIES ACT (ADA). FOR MULTI-USE PATH THE MAXIMUM RUNNING SLOPE IS 5% AND THE MAXIMUM CROSS SLOPES IS 2%.

EXISTING LEGEND

- EXISTING HMA PAVEMENT, VARIES 12"-13"
- EXISTING HMA SHOULDER
- EXISTING COMBINATION CURB AND GUTTER, TYPE B-6.12
- EXISTING COMBINATION CURB AND GUTTER, TYPE B-6.24
- EXISTING PORTLAND CEMENT CONCRETE SIDEWALK

PROPOSED LEGEND

- AGGREGATE SUBGRADE IMPROVEMENT 12"
- STABILIZED SUBBASE - HOT-MIX ASPHALT, 4 1/2"
- PORTLAND CEMENT CONCRETE PAVEMENT 9 3/4" (JOINTED)
- HOT-MIX ASPHALT SURFACE COURSE, MIX "D", N70, 1 1/2"
- POLYMERIZED HOT-MIX ASPHALT SURFACE COURSE, MIX "F", N90, 1 3/4"
- HOT-MIX ASPHALT PAVEMENT (FULL-DEPTH), 9"
- HOT-MIX ASPHALT SURFACE REMOVAL, 2 1/4"
- HOT-MIX ASPHALT SHOULDERS, 9"
- AGGREGATE SHOULDERS, TYPE B 9 3/4"
- COMBINATION CONCRETE CURB AND GUTTER, TYPE B-6.12
- COMBINATION CONCRETE CURB AND GUTTER, TYPE B-6.24
- HOT-MIX ASPHALT SURFACE REMOVAL, 2 1/4"
- CONCRETE MEDIAN SURFACE, 4 INCH
- M.C.C.D. BIKETRAIL (SEE NOTE 3 ON SHEET 16)
- PORTLAND CEMENT CONCRETE SIDEWALK 5 INCH
- PROPOSED TOPSOIL, 6" (SEE NOTE 6 ON SHEET 16)
- SEEDING, CLASS 2A
- BITUMINOUS MATERIALS (PRIME COAT)
- AGGREGATE (PRIME COAT)
- LONGITUDINAL CONSTRUCTION JOINT, WITH NO. 6 EPOXY COATED TIE BARS 30" LONG AT 24" CTS
- TOPSOIL FURNISH AND PLACE, 24"
- POROUS GRANULAR EMBANKMENT
- COURSE AGGREGATE FILL
- REMOVAL AND DISPOSAL OF UNSUITABLE MATERIAL
- ADDITIONAL 1 FOOT PAVEMENT RECONSTRUCTION
- SODDING, SALT TOLERANT
- POLYMERIZED LEVELING BINDER (MACHINE METHOD), IL-4.75, N50 - 3/4"
- HOT-MIX ASPHALT BASE COURSE WIDENING, 4 1/2"
- HOT-MIX ASPHALT BASE COURSE WIDENING, 9 1/4"
- PORTLAND CEMENT CONCRETE SHOULDERS 9 3/4"
- HOT-MIX ASPHALT BINDER COURSE, IL-19.0, N90 (2 1/4")
- HOT-MIX ASPHALT BINDER COURSE, IL-19.0, N70 2 1/4"
- CONCRETE MEDIAN, TYPE SB (SPECIAL)
- NO. 6 EPOXY COATED TIE BARS 24" LONG @ 24" CTS
- LONGITUDINAL SAWED JOINT, WITH NO. 6 EPOXY COATED TIE BARS 30" LONG AT 30" CTS

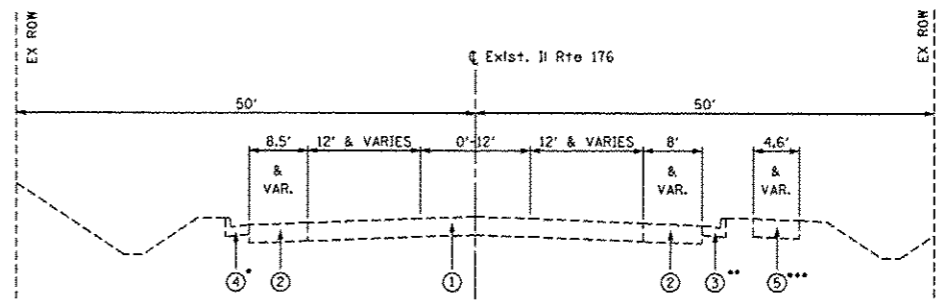

TYPICAL EXISTING CROSS SECTION IL ROUTE 176
STA. 590+23.80 TO STA. 608+50.50
* CC&G, TYPE B-6.12 STA. 601+58.00 TO STA. 607+13.00
** STA. 596+62.00 TO STA. 604+70.83
*** STA. 601+30.00 TO STA. 608+50.50

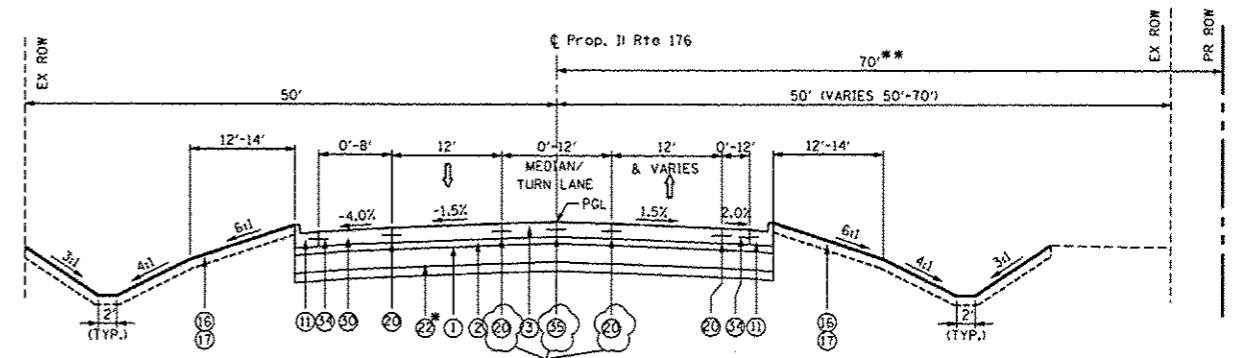

TYPICAL PROPOSED CROSS SECTION IL ROUTE 176
STA. 590+23.80 TO STA. 599+00.00
* SEE PGES LIMITS ON SHEET 18
** STA. 596+50 TO STA. 598+21.72

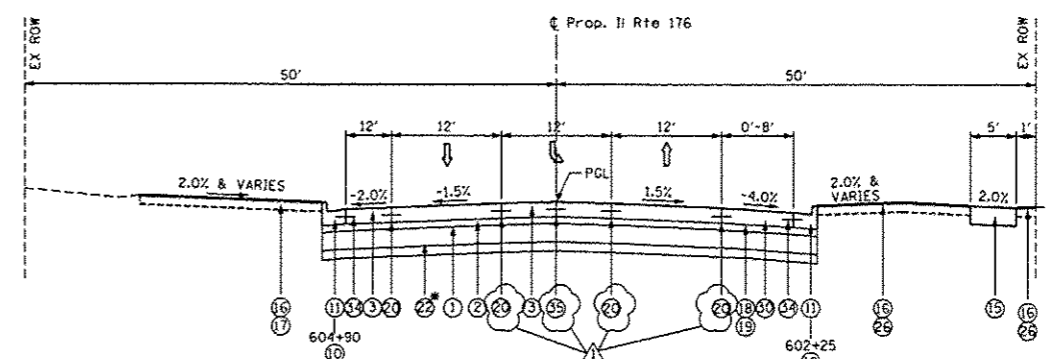

TYPICAL PROPOSED CROSS SECTION IL ROUTE 176
STA. 601+00.00 TO STA. 604+65.52
* SEE PGES LIMITS ON SHEET 18

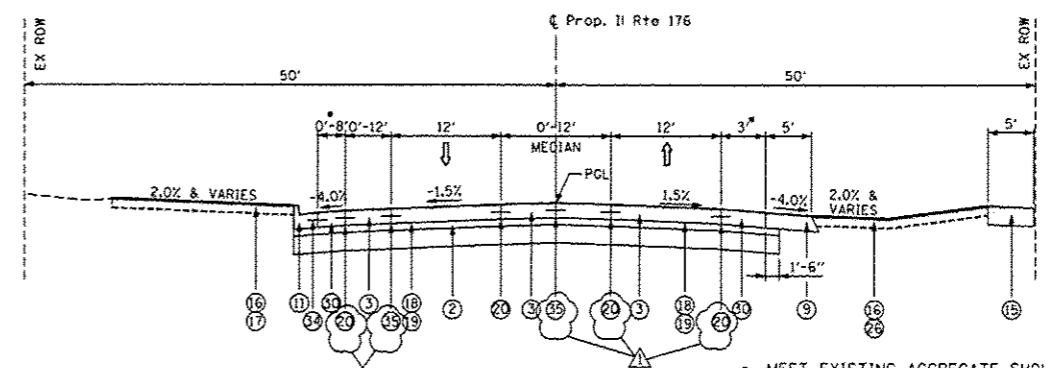

TYPICAL PROPOSED CROSS SECTION IL ROUTE 176
STA. 604+65.52 TO STA. 608+50.50
* MEET EXISTING AGGREGATE SHOULDER STA. 607+05.50 RT AND 607+94 LT

FILE NAME * S:\1686\4000 Sheets\0162517-ht-typical	USER NAME * Addendum - V01.dgn	DESIGNED - JPW	REVISED - 7/14/2014 HWL	STATE OF ILLINOIS DEPARTMENT OF TRANSPORTATION	TYPICAL SECTIONS IL ROUTE 176		F.A. RTE. 305	SECTION 27R-3	COUNTY MCHENRY	TOTAL SHEETS 431	SHEET NO. 16	
PLOT SCALE = 20.000 ' / IN.	CHECKED - MG2	REVISED -	REVISED -		SCALE:	SHEET NO. 16 OF 431 SHEETS	STA.	TO STA.	CONTRACT NO. 62517			
PLOT DATE = 7/14/2014	DATE = 10/15/2013	REVISED -	REVISED -		ILLINOIS FED. AID PROJECT							