

STATE OF ILLINOIS
DEPARTMENT OF TRANSPORTATION

ROUTE NO.	SECTION	COUNTY	TOTAL SHEETS	SHEET NO.
F.A.I. 57	••	IROQUOIS	190	69
FED. ROAD DIST. NO.	ILLINOIS	CONTRACT NO. 66757		
** (38-4)RS-2, (38-4)BR3				
Sheet 2 of 11 Sheets				

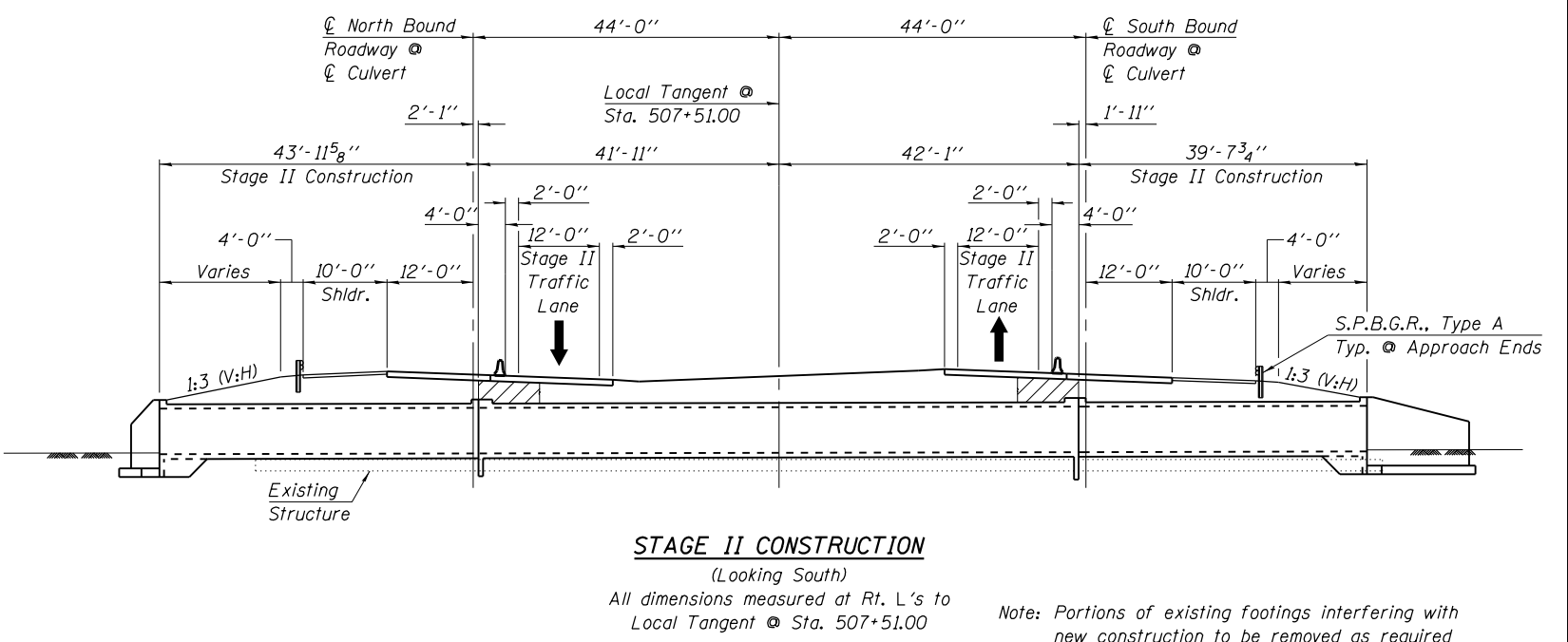
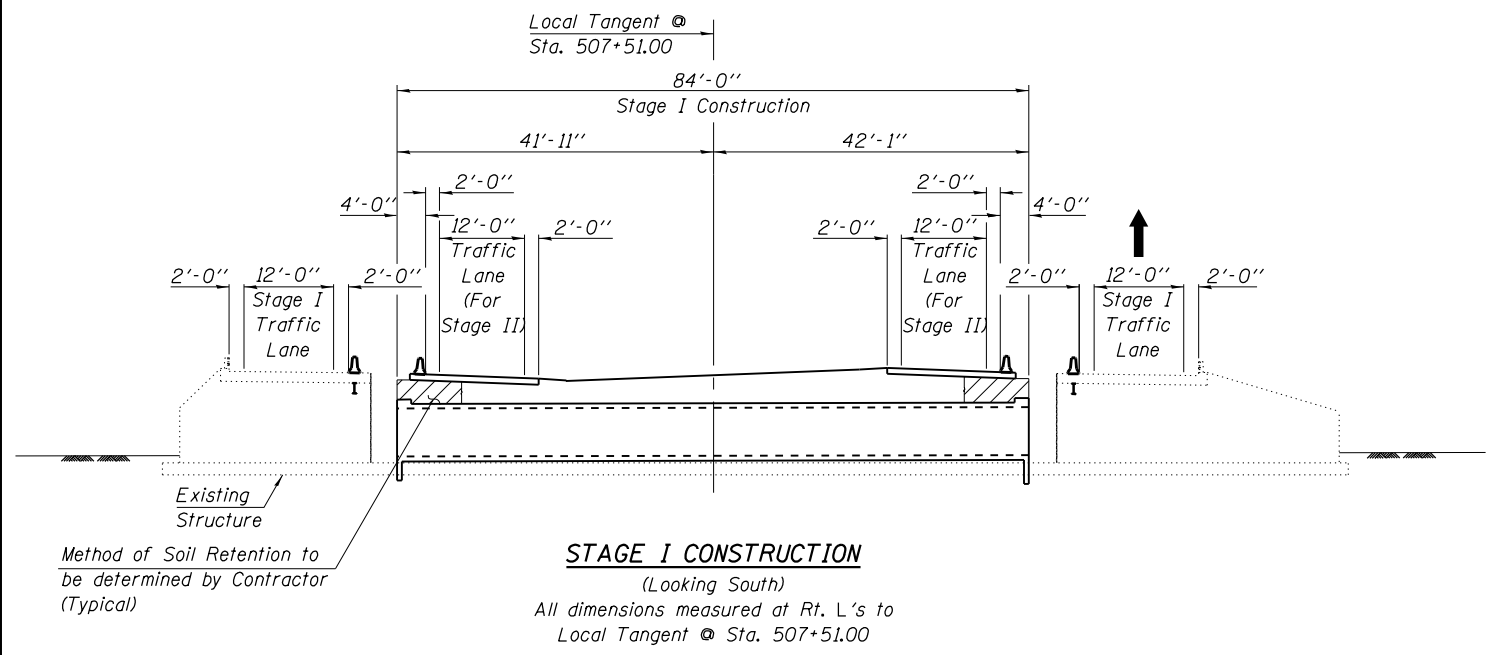
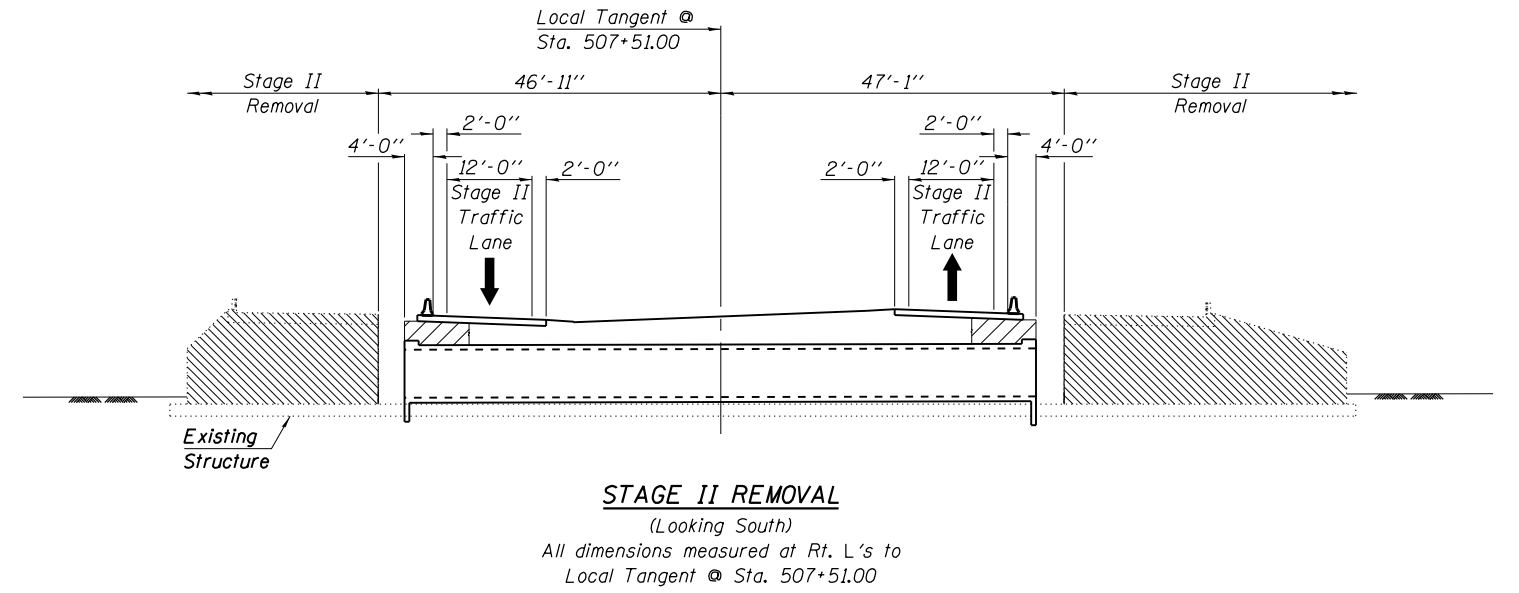
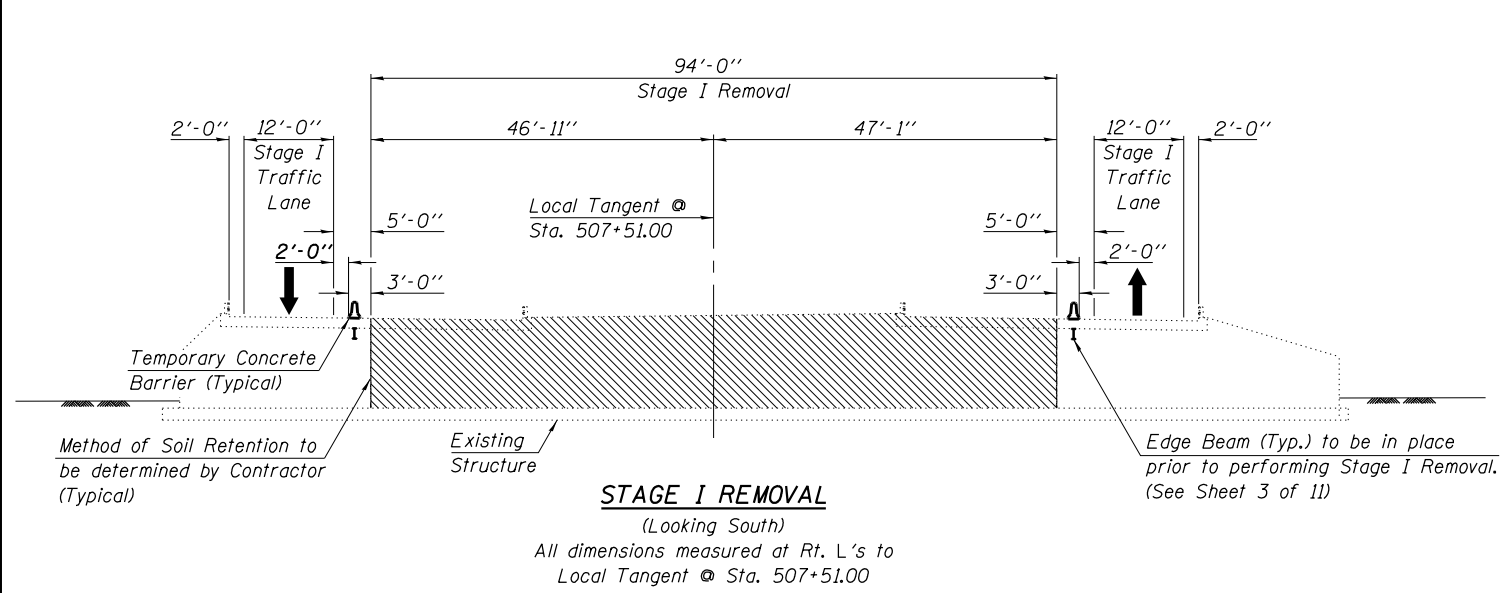

DESIGNED	S.F.M.
CHECKED	J.A.M.
DRAWN	S.A.P.
CHECKED	S.F.M. & J.A.M.

STAGE CONSTRUCTION DETAILS
I-57 OVER
DANFORTH TOWNSHIP DRAINAGE DITCH
F.A.I. ROUTE 57
SECTION (38-4)RS-2, (38-4)BR3
IROQUOIS COUNTY
STATION 507+51.00
S.N. 038-2019

4440 ASH GROVE SPRINGFIELD, IL 62711 (217) 793-8600 www.fehr-graham.com	FEHR-GRAHAM & ASSOCIATES, LLC ENGINEERING AND SCIENCE CONSULTANTS FREEPORT, IL, ROCKFORD, IL, ROCKFORD, IL, SPRINGFIELD, IL	JOB NO.: 46810K FILE: STAGING.DGN DATE: 11/11/08
--	---	--