

LINEAR DELINEATION PANEL

NOTE: THIS DETAIL DENOTES 1 FULL 12.5' SECTION OF TEMPORARY CONCRETE BARRIER.

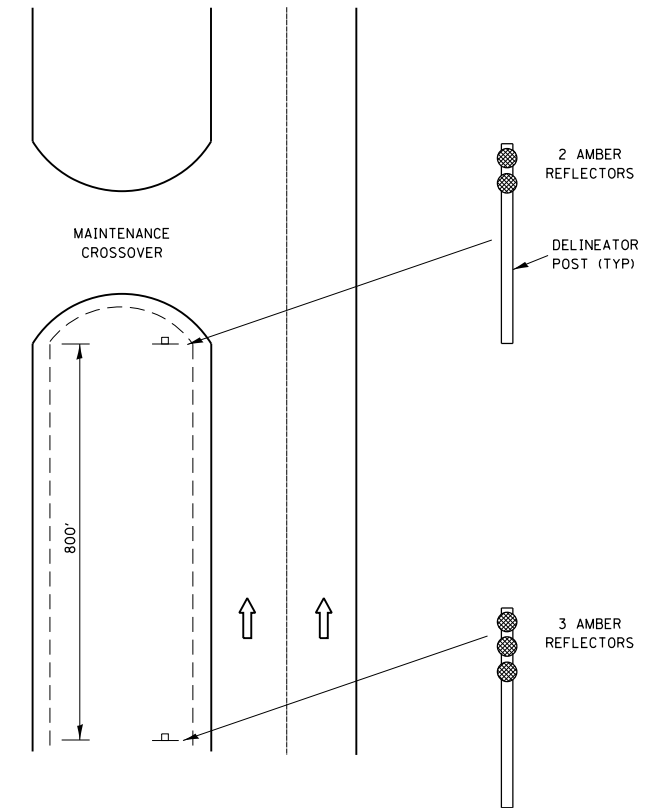

**DELINEATION
FOR MAINTENANCE
CROSSOVER
(TYPICAL FOR BOTH DIRECTIONS)**

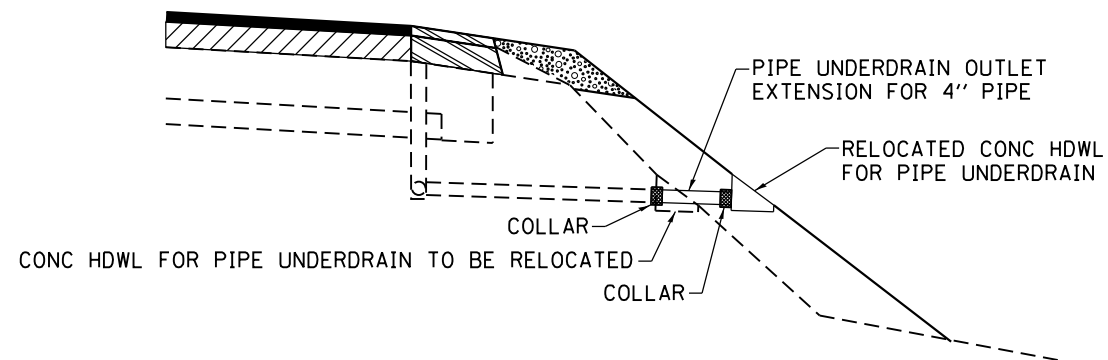

PIPE UNDERDRAIN TO BE FIELD LOCATED BY THE CONTRACTOR AND AS DIRECTED BY THE ENGINEER

PIPE UNDERDRAIN OUTLET EXTENSION SPECIAL

FILE NAME =	USER NAME = duncanbd	DESIGNED -	REVISED -	STATE OF ILLINOIS DEPARTMENT OF TRANSPORTATION	DETAILS			F.A.I. RTE.	SECTION	COUNTY	TOTAL SHEETS	SHEET NO.
et:\pwork\pwork\duncanbd\dms30308\ep05005-shit-details.dgn	DRAWN -	REVISED -	57					*	IR000UIS	190	93	
PLOT SCALE = 100.0000' / in.	CHECKED -	REVISED -	SCALE:		SHEET NO.	OF SHEETS	STA.	TO STA.	CONTRACT NO. 66757			
PLOT DATE = 6/2/2014	DATE -	REVISED -						FED. ROAD DIST. NO.	ILLINOIS FED. AID PROJECT			