

NOTE:
 WHEN MILLING OPERATIONS PRODUCE A ROUNDED EDGE, THEN A SAW CUT SHALL BE USED TO MANUFACTURE A PERPENDICULAR EDGE AS SHOWN IN THE DETAIL. THE ENGINEER SHALL BE THE SOLE JUDGE CONCERNING THE USE OF THIS DETAIL

HMA DETAIL AT BUTT JOINTS

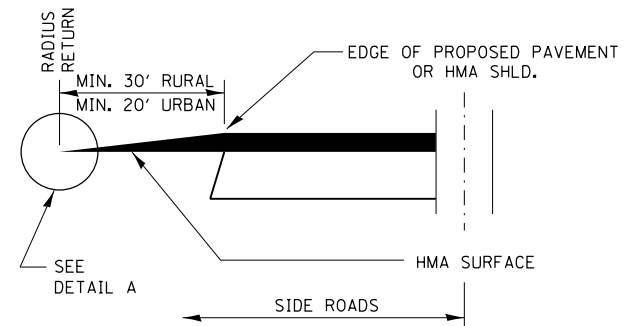

SECTION A-A DETAILS AT SIDE ROADS

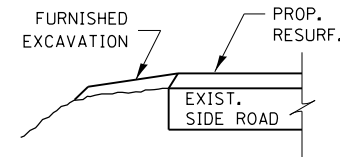

SECTION B-B

THE COST OF REMOVAL AT EXISTING HMA OR P.C.C. LOCATIONS SHALL BE PAID FOR PER SQ. YD. BY THE APPROPRIATE PAY ITEM. REMOVAL AT THE EXISTING AGG. LOCATIONS SHALL BE INCIDENTAL TO THE HMA. A-3 LOCATIONS SHALL BE FEATHER TAPERED.

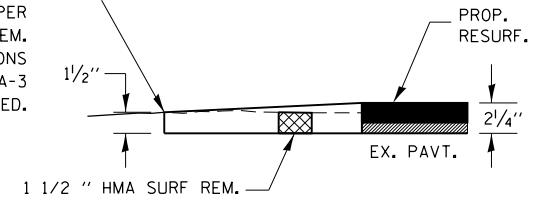

DETAIL A

SIDERoads IN RURAL SECTION. IN URBAN SECTION MILLING & RESURFACING WILL BE 2 1/4'

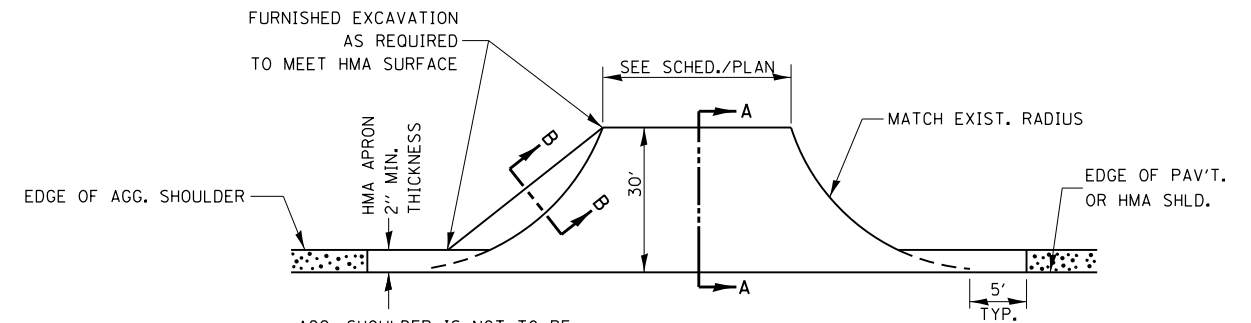

PLAN AT SIDE ROADS

FILE NAME =	USER NAME = duncanbd	DESIGNED -	REVISED -
et:\pwork\pwork\dot\duncanbd\0373950\0386047-shd-details.dgn		DRAWN -	REVISED -
	PLOT SCALE = 100.0000' / in.	CHECKED -	REVISED -
	PLOT DATE = 6/4/2014	DATE -	REVISED -

STATE OF ILLINOIS
 DEPARTMENT OF TRANSPORTATION

DETAILS

SCALE: SHEET NO. OF SHEETS STA. TO STA.

F.A.P. RTE.	SECTION	COUNTY	TOTAL SHEETS	SHEET NO.
68	(29,30)RS-4	DEKALB	26	24
CONTRACT NO. 66952				
ILLINOIS FED. AID PROJECT				