

TYPICAL SECTION
STA. 129+32 TO STA. 142+32

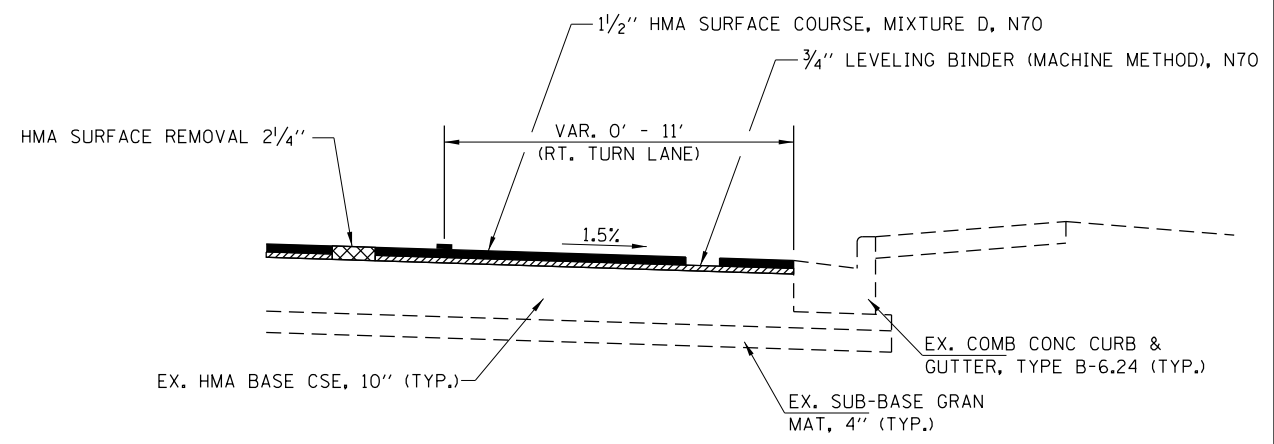

RT. TURN LANE DETAIL
STA. 151+68 TO STA. 153+57

MIXTURES TABLE			
	HMA SURFACE	HMA LEVELING BINDER	INCIDENTAL HMA SURFACING
PG GRADE**	PG 64-22	PG 64-22	PG 64-22
DESIGN AIR VOIDS	4.0% @ N70	4.0% @ N70	4.0% @ N50
MIXTURE COMPOSITION	IL 9.5	IL 9.5 FG	IL 9.5
FRICTION AGGREGATE	MIXTURE D		MIXTURE C
DENSITY CONTROL METHOD	CORRELATION	CORRELATION	SATISFACTION OF ENGINEER

** WHEN RAP/RAS ABR EXCEEDS 20 PERCENT, THE HIGH AND LOW VIRGIN ASPHALT BINDER GRADES SHALL EACH BE REDUCED BY ONE GRADE (I.E. 25% ABR WOULD REQUIRE A VIRGIN ASPHALT BINDER GRADE OF PG 64-22 TO BE REDUCED TO PG 58-28)

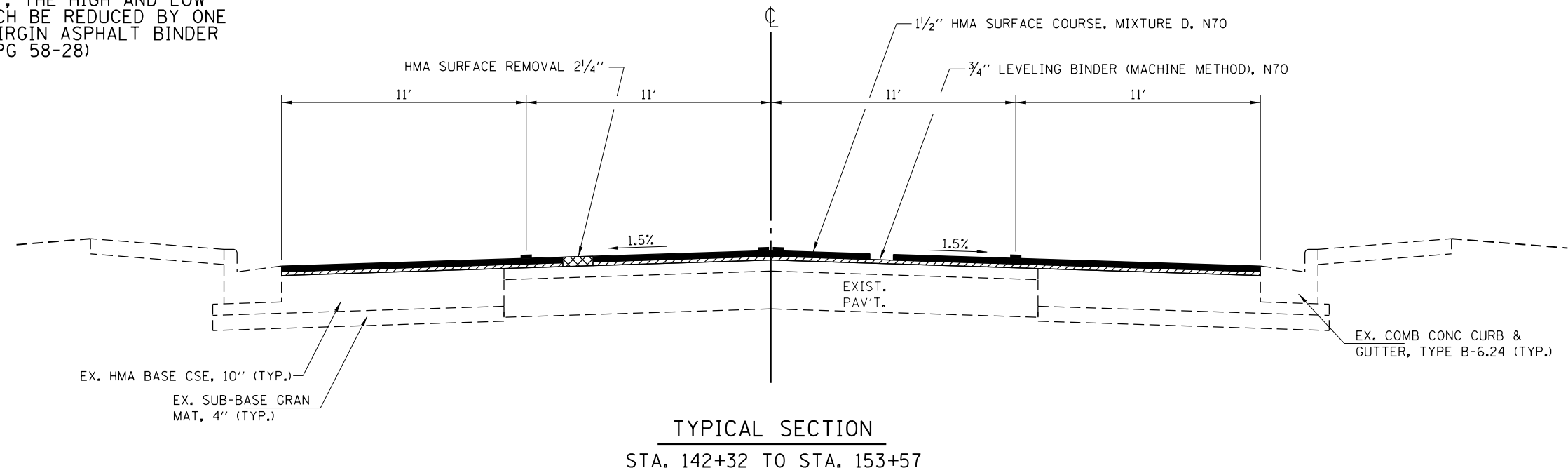

TYPICAL SECTION
STA. 142+32 TO STA. 153+57