

PROPOSED HIGHWAY PLANS

F.A.P. ROUTE 697 (IL ROUTE 9)
SECTION (27-1HB-2)IR

BRIDGE REPAIRS

STRUCTURE NO. 027-0010

IL 9 OVER I-57 (PAXTON INTERCHANGE)

FORD COUNTY

C-93-097-14

F.A.P. RITE	SECTION	COUNTY	TOTAL SHEETS	SHEET NO.
697	(27-1HB-2)IR	FORD	27	1
ILLINOIS		CONTRACT NO. 66D74		

D-93-002-14



LOCATION OF SECTION INDICATED THUS: —

RURAL		RURAL	
MINOR ARTERIAL		INTERSTATE	
FAP 697 (IL 9)		FAR RTE. 57	
2013		2013	
ADT	5800	ADT	16700
P.V.	85.52%	P.V.	61.82%
S.U.	9.91%	S.U.	5.99%
M.U.	4.57%	M.U.	32.19%

STATE OF ILLINOIS
DEPARTMENT OF TRANSPORTATION
DIVISION OF HIGHWAYS

SUBMITTED May 19 20 14
Paul Loetz a.s.
DEPUTY DIRECTOR OF HIGHWAYS, REGION ENGINEER

June 27 20 14
John D. Baranzelli R.E.
a.s. ENGINEER OF DESIGN AND ENVIRONMENT

June 27 20 14
Omer Osman R.E.
DIRECTOR OF HIGHWAYS, CHIEF ENGINEER

PRINTED BY THE AUTHORITY
OF THE STATE OF ILLINOIS

1. COVER SHEET
2. GENERAL NOTES
- 3-6. SUMMARY OF QUANTITIES
7. TYPICAL SECTIONS
8. STAGE I TRAFFIC CONTROL PLANS
9. STAGE II TRAFFIC CONTROL PLANS
10. TEMPORARY INFORMATION SIGNING
11. PAVEMENT MARKINGS
12. EXISTING PLAN AND ELEVATION - REMOVAL
13. EXISTING PLAN AND ELEVATION - CONSTRUCTION
- 14-15. BRIDGE APPROACH PAVEMENT
16. ELECTRICAL DETAILS
- 17-27. STRUCTURE REPAIR PLANS.

STANDARDS

000001-06	STANDARD SYMBOLS, ABBREVIATIONS AND PATTERNS
001001-02	AREAS OF REINFORCEMENT BARS
001006	DECIMAL OF AN INCH AND OF A FOOT
420001-07	PAVEMENT JOINTS
420401-10	BRIDGE APPROACH PAVEMENT CONNECTOR
420701-02	PAVEMENT FABRIC
421001-02	BAR REINFORCEMENT FOR CRC PAVEMENT
483001-04	PCC SHOULDER
606001-05	CONCRETE CURB TYPE B AND COMBINATION CONCRETE CURB AND GUTTER
606301-04	PC CONCRETE ISLANDS AND MEDIANS
631031-12	TRAFFIC BARRIER TERMINAL, TYPE 6
701201-04	LANE CLOSURE, 2L, 2W, DAY ONLY, FOR SPEEDS ≥ 45 MPH
701206-03	LANE CLOSURE, 2L, 2W, NIGHT ONLY, FOR SPEEDS ≥ 45 MPH
701301-04	LANE CLOSURE, 2L, 2W, SHORT TIME OPERATIONS
701311-03	LANE CLOSURE, 2L, 2W, MOVING OPERATIONS - DAY ONLY
701316-08	LANE CLOSURE, 2L, 2W, BRIDGE REPAIR, FOR SPEEDS ≥ 45 MPH
701400-07	APPROACH TO LANE CLOSURE, FREEWAY/EXPRESSWAY
701406-08	LANE CLOSURE, FREEWAY/EXPRESSWAY, DAY OPERATIONS ONLY
701428	TRAFFIC CONTROL SETUP AND REMOVAL FREEWAY/EXPRESSWAY
701901-03	TRAFFIC CONTROL DEVICES
862001-01	UNINTERRUPTABLE POWER SUPPLY (UPS)
880001-01	SPAN WIRE MOUNTED SIGNALS AND FLASHING BEACON INSTALLATION

PROJECT LOCATION
STRUCTURE NO. 027-0010

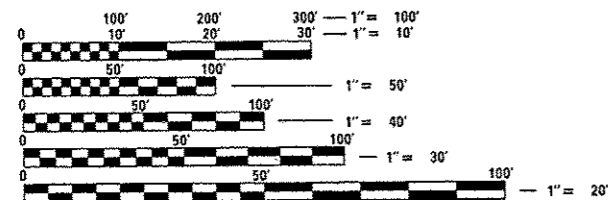

FULL SIZE PLANS HAVE BEEN PREPARED USING STANDARD ENGINEERING SCALES. REDUCED SIZED PLANS WILL NOT CONFORM TO STANDARD SCALES. IN MAKING MEASUREMENTS ON REDUCED PLANS, THE ABOVE SCALES MAY BE USED.

J.U.L.I.E.
JOINT UTILITY LOCATION INFORMATION FOR EXCAVATION
1-800-892-0123
OR 811

PROJECT ENGINEER: JOE KANNEL P.E.
UNIT CHIEF: RON WOODSHANK
TOWNSHIP: PATTON
CONTRACT NO. 66D74

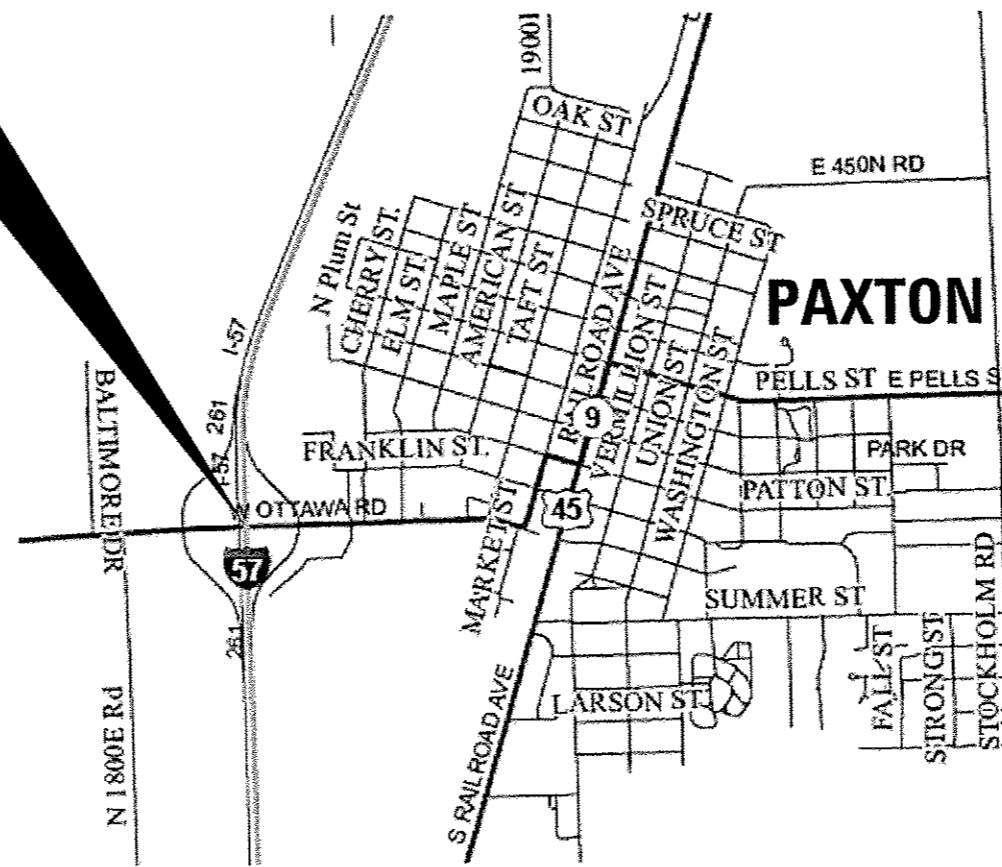

POINT LOCATION
GROSS LENGTH = 261 FT. = 0.0494 MILE

GENERAL NOTES

THE THICKNESS OF HMA SHOWN ON THE PLANS IS THE NOMINAL THICKNESS. DEVIATIONS FROM THE NOMINAL THICKNESS WILL BE PERMITTED WHEN SUCH DEVIATIONS OCCUR DUE TO IRREGULARITIES IN THE EXISTING SURFACE OR BASE ON WHICH THE HMA IS PLACED.

THE ENGINEER WILL BE THE SOLE JUDGE CONCERNING CURING TIME FOR THE VARIOUS HMA LIFTS.

FOR STABILIZATION, ALL TYPE III BARRICADES WILL REQUIRE A MINIMUM OF FOUR SAND BAGS PER BARRICADE.

ALL EXCAVATED MATERIAL, WHICH INCLUDES DIGGING OR GRADING OF ANY SOIL OR FILL MATERIAL, WITH THE EXCEPTION OF AGGREGATE FILLS, MUST BE INCORPORATED WITHIN THE IDOT RIGHT OF WAY DUE TO ENVIRONMENTAL DOCUMENTATION REQUIREMENTS.

ON EXISTING PAVEMENT WHICH MAY BE SUPERELEVATED, THE NEW HMA PAVEMENT SHALL BE BUILT WITH THE SAME SUPERELEVATION UNLESS NEW SUPERELEVATION RATES ARE GIVEN ON THE PLANS.

ANY REFERENCE TO A STANDARD IN THESE PLANS SHALL BE INTERPRETED TO MEAN THE EDITION AS INDICATED BY THE SUBNUMBER SHOWN IN THE LIST OF STANDARDS OR THE COPY INCLUDED IN THESE PLANS.

THE FOLLOWING RATES OF APPLICATION HAVE BEEN USED IN CALCULATING PLAN QUANTITIES:

GRANULAR MATERIALS	2.05	TONS / CU YD
HMA RESURFACING	112	LBS / SQ YD / IN

THE CONTRACTOR SHALL CONTACT JULIE AT LEAST 48 HOURS PRIOR TO EXCAVATION TO DETERMINE WHICH UTILITIES ARE IN THE AREA.

COMMITMENTS

DATE: 5-19-14

PREPARED BY: *Don Benil*
DISTRICT STUDIES & PLANS ENGINEER

EXAMINED BY: _____
DISTRICT CONSTRUCTION ENGINEER

DISTRICT MATERIALS ENGINEER

DISTRICT OPERATIONS ENGINEER

FILE NAME :	USER NAME :	DESIGNED :	REVISED :	STATE OF ILLINOIS DEPARTMENT OF TRANSPORTATION	GENERAL NOTES	F.A.P. RTE.	SECTION	COUNTY	TOTAL SHEETS	SHEET NO.	
c:\pwork\p1dot\woodshankr\140380312\	woodshankr1	RON WOODSHANK	-			697	(27-1H8-2)R	FORD	27	2	
366074-sht-details.dgn		DRAWN :	REVISED :			CONTRACT NO. 66D74					
		RON WOODSHANK	-			ILLINOIS FED. AID PROJECT					
PLOT SCALE : 100.00' / in.		CHECKED :	REVISED :	SCALE: _____	SHEET NO. 1 OF 1 SHEETS	STA. _____	TO STA. _____				
PLOT DATE : 5/19/2014		DATE :	REVISED :								
		2/10/2014	-								

CODE NO.	ITEM	UNIT	TOTAL QUANTITY	CONSTR. CODE
				CONT MAINT
				100%
				BRIDGE
				0014
				027-0010
20200100	EARTH EXCAVATION	CU YD	81	81
31101200	SUBBASE GRANULAR MATERIAL, TYPE B 4"	SQ YD	340	340
42001420	BRIDGE APPROACH PAVEMENT CONNECTOR (PCC)	SQ YD	58	58
44000100	PAVEMENT REMOVAL	SQ YD	101	101
44000500	COMBINATION CURB AND GUTTER REMOVAL	FOOT	840	840
44004250	PAVED SHOULDER REMOVAL	SQ YD	80	80
50102400	CONCRETE REMOVAL	CU YD	57.8	57.8
50157300	PROTECTIVE SHIELD	SQ YD	4	4
50300225	CONCRETE STRUCTURES	CU YD	57.2	57.2
50300255	CONCRETE SUPERSTRUCTURE	CU YD	133.6	133.6
50300300	PROTECTIVE COAT	SQ YD	1304	1304
50800205	REINFORCEMENT BARS, EPOXY COATED	POUND	39440	39440
50800515	BAR SPLICERS	EACH	128	128
50800530	MECHANICAL SPLICERS	EACH	236	236

FILE NAME = c:\pwork\pwork\woodshankr\149380312\

USER NAME = woodshankr-1
 366074-shr-details.dgn
 PLOT SCALE = 100.00 / 1" = 100'
 PLOT DATE = 5/19/2014

DESIGNED - RON WOODSHANK
 DRAWN - RON WOODSHANK
 CHECKED - YOGESH PATEL
 DATE - 2/10/2014

REVISED - _____
 REVISED - _____
 REVISED - _____
 REVISED - _____

STATE OF ILLINOIS
 DEPARTMENT OF TRANSPORTATION

SUMMARY OF QUANTITIES
 SCALE: _____ SHEET NO. 1 OF 4 SHEETS STA. _____ TO STA. _____

F.A.P. RTE. 69T SECTION (27-1HB-2)1R COUNTY FORD TOTAL SHEETS 27 SHEET NO. 3 CONTRACT NO. 66074 ILLINOIS FED. AID PROJECT

Rev.

CODE NO.	ITEM	UNIT	TOTAL QUANTITY	CONSTR. CODE
				CONT MAINT 100% BRIDGE 0014 027-0010
52000110	PREFORMED JOINT STRIP SEAL	FOOT	114	114
60608600	COMBINATION CONCRETE CURB AND GUTTER, TYPE M-6.06	FOOT	40	40
60608700	COMBINATION CONCRETE CURB AND GUTTER, TYPE M-6.06 (ABUTTING EXISTING PAVEMENT)	FOOT	800	800
60618300	CONCRETE MEDIAN SURFACE, 4 INCH	SQ FT	5635	5635
63302700	REMOVE AND REERECT TRAFFIC BARRIER TERMINALS, TYPE 6	EACH	4	4
67000400	ENGINEER'S FIELD OFFICE, TYPE A	CAL MO	4	4
67100100	MOBILIZATION	L SUM	1	1
70100100	TRAFFIC CONTROL AND PROTECTION, STANDARD 701316	EACH	1	1
70100450	TRAFFIC CONTROL AND PROTECTION, STANDARD 701201	L SUM	1	1
70100700	TRAFFIC CONTROL AND PROTECTION, STANDARD 701406	L SUM	1	1
70103815	TRAFFIC CONTROL SURVEILLANCE	CAL DA	10	10
70106500	TEMPORARY BRIDGE TRAFFIC SIGNALS	EACH	1	1
78009000	MODIFIED URETHANE PAVEMENT MARKING - LETTERS AND SYMBOLS	SQ FT	94	94
78009004	MODIFIED URETHANE PAVEMENT MARKING - LINE 4"	FOOT	800	800

* Specialty Items

CODE NO.	ITEM	UNIT	TOTAL QUANTITY	CONSTR. CODE
				CONT MAINT 100% BRIDGE 0014 027-0010
78009008	MODIFIED URETHANE PAVEMENT MARKING - LINE 8"	FOOT	633	633
78200300	PRISMATIC CURB REFLECTOR	EACH	70	70
78200410	GUARDRAIL MARKERS, TYPE A	EACH	12	12
78300100	PAVEMENT MARKING REMOVAL	SO FT	264	264
81028750	UNDERGROUND CONDUIT, COILABLE NONMETALLIC CONDUIT, 2" DIA.	FOOT	990	990
81100600	CONDUIT ATTACHED TO STRUCTURE, 2" DIA., GALVANIZED STEEL	FOOT	78	78
81702415	ELECTRIC CABLE IN CONDUIT, 600V (XLP-TYPE USE) 3-1/C NO. 6	FOOT	1310	1310
89502300	REMOVE ELECTRIC CABLE FROM CONDUIT	FOOT	1310	1310
89502350	REMOVE AND REINSTALL ELECTRIC CABLE FROM CONDUIT	FOOT	15	15
X0322194	POLYMER MODIFIED PORTLAND CEMENT MORTAR	SO FT	98	98
X0323078	REMOVE AND RE-ERECT EXISTING BRIDGE RAIL	FOOT	40	40
X0323710	REMOVE CONDUIT ATTACHED TO STRUCTURE	FOOT	78	78
X0326649	LINEAR DELINEATOR PANELS, 6 INCH	EACH	6	6
X2020502	BRACED EXCAVATION	CU YD	66	66
X5080525	BAR SPLICERS, SPECIAL	EACH	8	8

* Specialty Items

Rev.

FILE NAME :	USER NAME : woodshankr1	DESIGNED - RON WOODSHANK	REVISED -	STATE OF ILLINOIS DEPARTMENT OF TRANSPORTATION	SUMMARY OF QUANTITIES	F.A.P. RTE.	SECTION	COUNTY	TOTAL SHEETS	SHEET NO.
366074-sht-detailed.dgn	DRAWN - RON WOODSHANK	REVISED -	697			127-1HB-21R	FORD	27	5	
PLOT SCALE = 100.00' / 1" =	CHECKED - YOCESH PATEL	REVISED -	CONTRACT NO. 66D74							
PLOT DATE = 5/19/2014	DATE - 2/10/2014	REVISED -	ILLINOIS FED. AID PROJECT							

SCALE: _____ SHEET NO. 3 OF 4 SHEETS STA. _____ TO STA. _____

CODE NO.	ITEM	UNIT	TOTAL QUANTITY	CONSTR. CODE
				CONT MAINT 100% BRIDGE 0014 027-0010
X4400110	TEMPORARY PAVEMENT REMOVAL	SQ YD	301	301
X5860110	GRANULAR BACKFILL FOR STRUCTURES	CU YD	66	66
X8130120	RELOCATE EXISTING JUNCTION BOX	EACH	1	1
X7010410	SPEED DISPLAY TRAILER	CAL MO	0.5	0.5
Z0004552	APPROACH SLAB REMOVAL	SQ YD	125	125
Z0012754	STRUCTURAL REPAIR OF CONCRETE (DEPTH EQUAL TO OR LESS THAN 5 INCHES)	SQ FT	31	31
Z0024478	FLEXIBLE DELINEATORS	EACH	4	4
Z0033024	MAINTAIN EXISTING LIGHTING SYSTEM	L SUM	1	1
Z0062456	TEMPORARY PAVEMENT	SQ YD	301	301

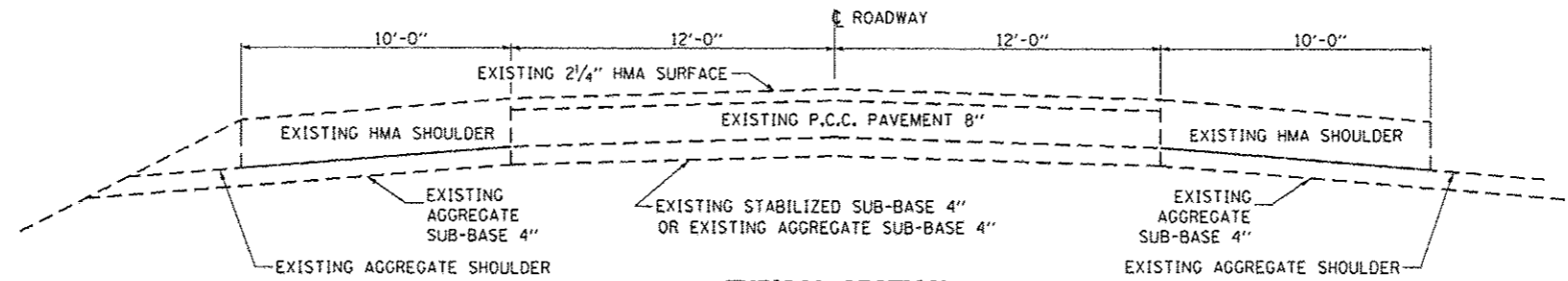

TYPICAL SECTION 1
F.A.P. ROUTE 697 (IL 9)
STA. 6+72 TO STA. 10+80

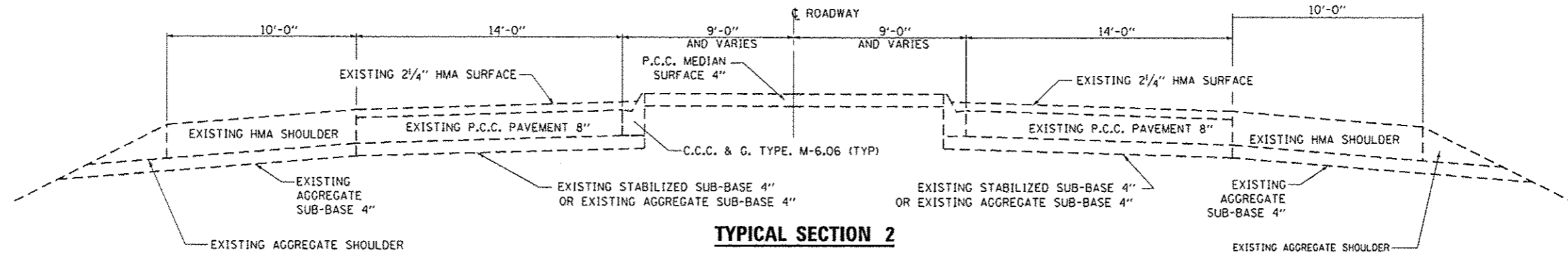

TYPICAL SECTION 2
F.A.P. ROUTE 697 (IL 9)
STA. 10+80 TO STA. 39+50

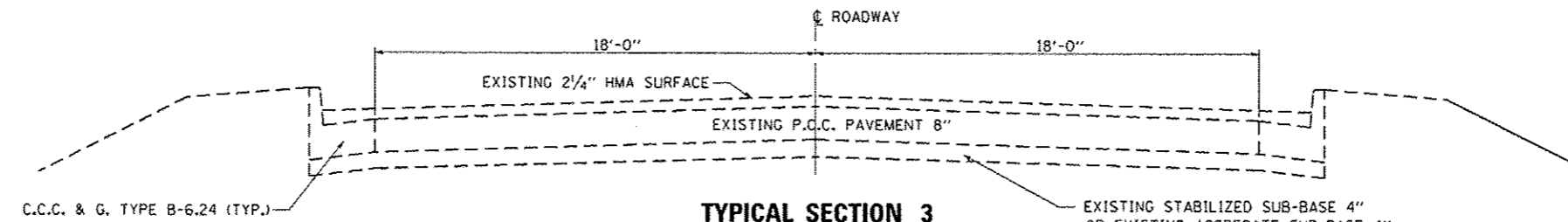

TYPICAL SECTION 3
F.A.P. ROUTE 697 (IL 9)
STA. 39+50 TO STA. 41+00

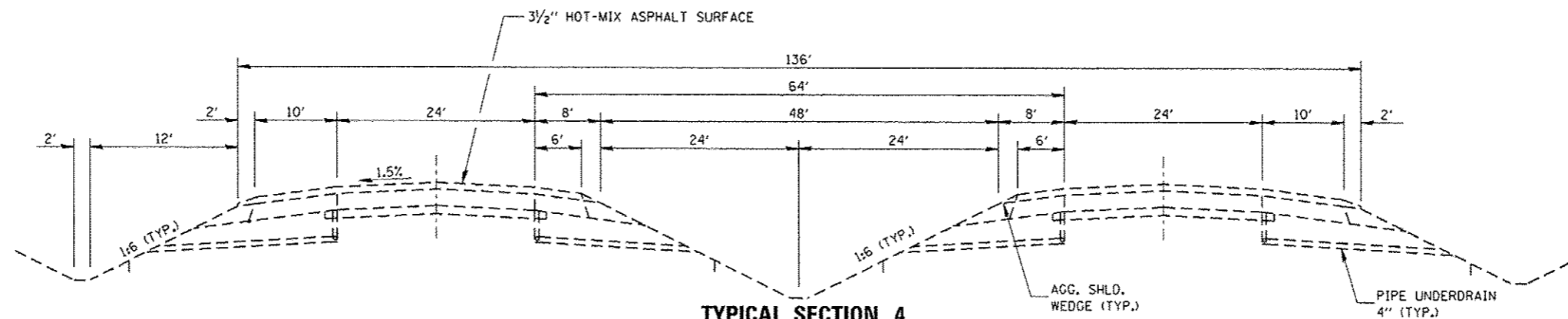

TYPICAL SECTION 4
F.A.I. ROUTE 57 (I-57)

FILE NAME =	USER NAME = woodshank-1	DESIGNED - RON WOODSHANK	REVISED -
c:\pav\work\pavdot\woodshank\1409380312\666074.sht-details.dgn		DRAWN - RON WOODSHANK	REVISED -
		CHECKED - YOGESH PATEL	REVISED -
		DATE - 2/10/2014	REVISED -

STATE OF ILLINOIS
DEPARTMENT OF TRANSPORTATION

TYPICAL SECTIONS
SCALE: _____ SHEET NO. 1 OF 1 SHEETS STA. _____ TO STA. _____

F.A.P. RTE. 697	SECTION (27-IHB-2)IR	COUNTY FORD	TOTAL SHEETS 27	SHEET NO. 7
				CONTRACT NO. 66D74
ILLINOIS FED. AID PROJECT				



HMA MIXTURE REQUIREMENTS FOR TEMPORARY PAVEMENT

	HMA BINDER
PG GRADE	PG64-22
DESIGN AIR	4.0%
VOIDS	φ N90
MIXTURE COMPOSITION	IL 19.0
FRICTION	
AGGREGATE	
DENSITY CONTROL METHOD	SATISFACTION OF THE ENGINEER



R10-6A-2430

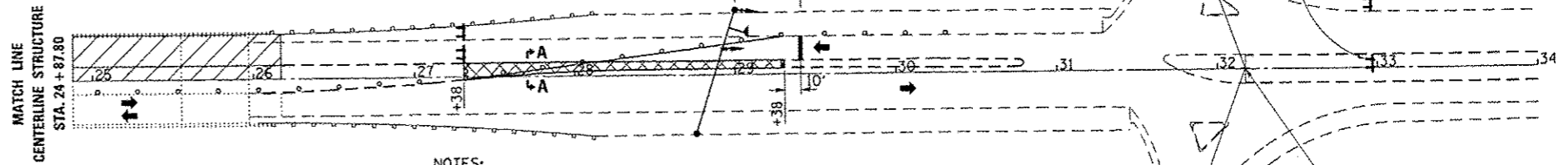
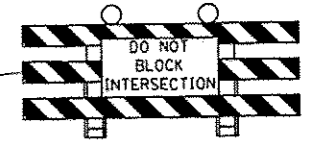

- NOTES:
1. WORK ON MEDIANS SHALL BE COMPLETED PRIOR TO ERECTING STAGE I TRAFFIC CONTROL FOR STAGE I WORK.
 2. FURNISHING AND PLACING TEMPORARY HOT-MIX ASPHALT PAVEMENT WILL BE PAID FOR AS "TEMPORARY PAVEMENT". REMOVAL WILL BE PAID FOR AS "TEMPORARY PAVEMENT REMOVAL".

STA. 32+17.03 IL RTE. 9 =
STA. 0+00.00 RAMP "A" =
STA. 12+80.84 RAMP "B"

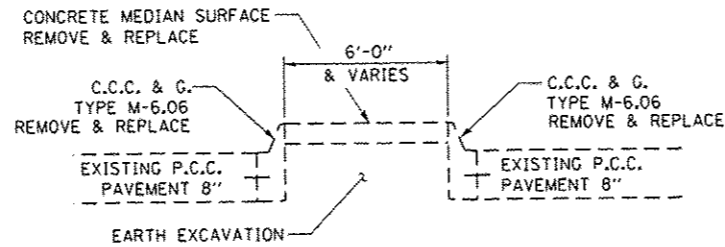

EXISTING SECTION A-A

STA. 20+37 - STA. 22+37
STA. 27+38 - STA. 29+38

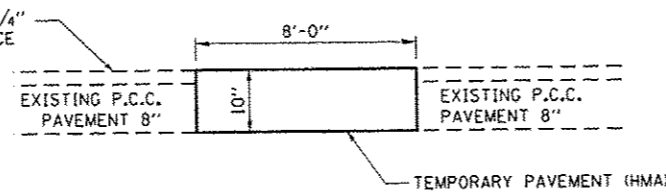

PROPOSED SECTION A-A

STA. 20+37 - STA. 22+37
STA. 27+38 - STA. 29+38

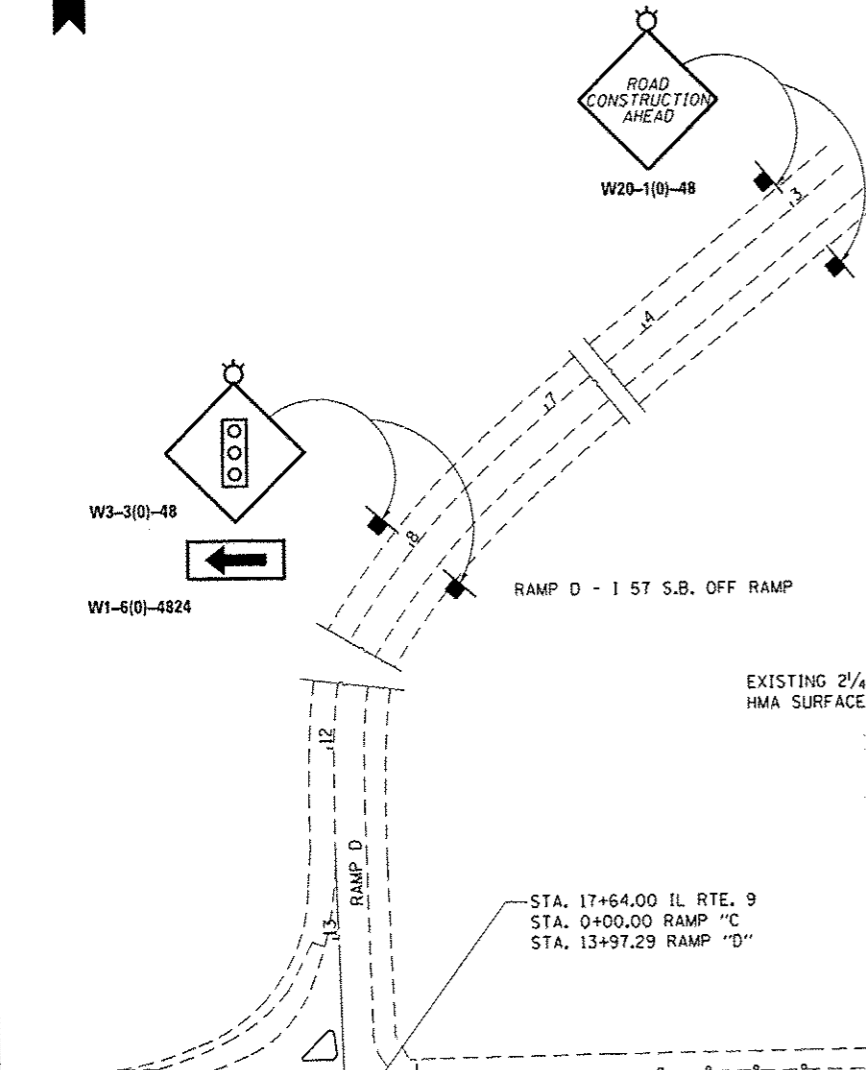

STA. 17+64.00 IL RTE. 9
STA. 0+00.00 RAMP "C"
STA. 13+97.29 RAMP "D"

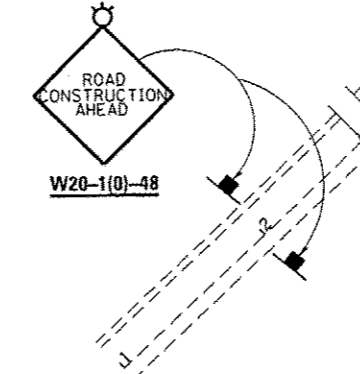

LEGEND

- TYPE III BARRICADE
- MICROWAVE DETECTOR
- TRAFFIC SIGNAL HEAD WITH BACKPLATE & POST
- CABLE MOUNTED TRAFFIC SIGNAL HEAD WITH BACKPLATE
- WOOD POST
- BARRICADE OR DRUM WITH STEADY BURN LIGHTS AT 25FT C-C
- WORK ZONE
- TEMPORARY HMA PAVEMENT CONSTRUCTED PRIOR TO STAGE I BRIDGE WORK
- SIGN-POST MOUNTED

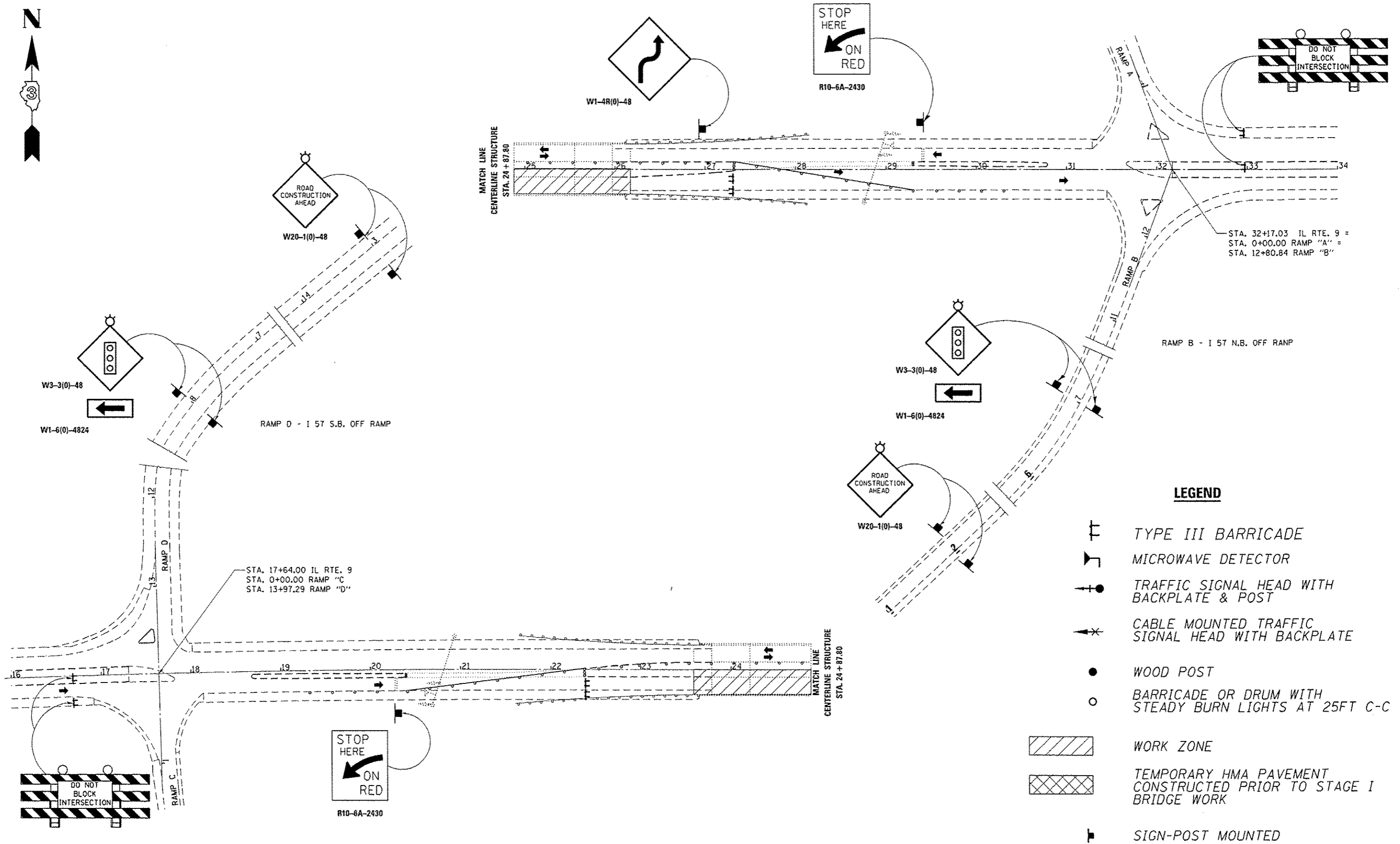

FILE NAME :	USER NAME :	DESIGNED :	REVISED :
c:\p\work\p\stdoc\woodshankr\148388312\	woodshankr-l	RON WOODSHANK	-
	366074-shs-detail.dgn	DRAWN :	REVISED :
		RON WOODSHANK	-
	PLOT SCALE = 1/8" = 1' / in.	CHECKED :	REVISED :
		YOGESH PATEL	-
	PLOT DATE = 5/19/2014	DATE :	REVISED :
		2/10/2014	-

**STATE OF ILLINOIS
DEPARTMENT OF TRANSPORTATION**

**STAGE II
TRAFFIC CONTROL PLANS**

SCALE: _____ SHEET NO. 2 OF 2 SHEETS STA. _____ TO STA. _____

F.A.P. RTE.:	SECTION	COUNTY	TOTAL SHEETS	SHEET NO.
697	127-1HB-21R	FORD	27	9
CONTRACT NO. 66D74			ILLINOIS FED. AID PROJECT	

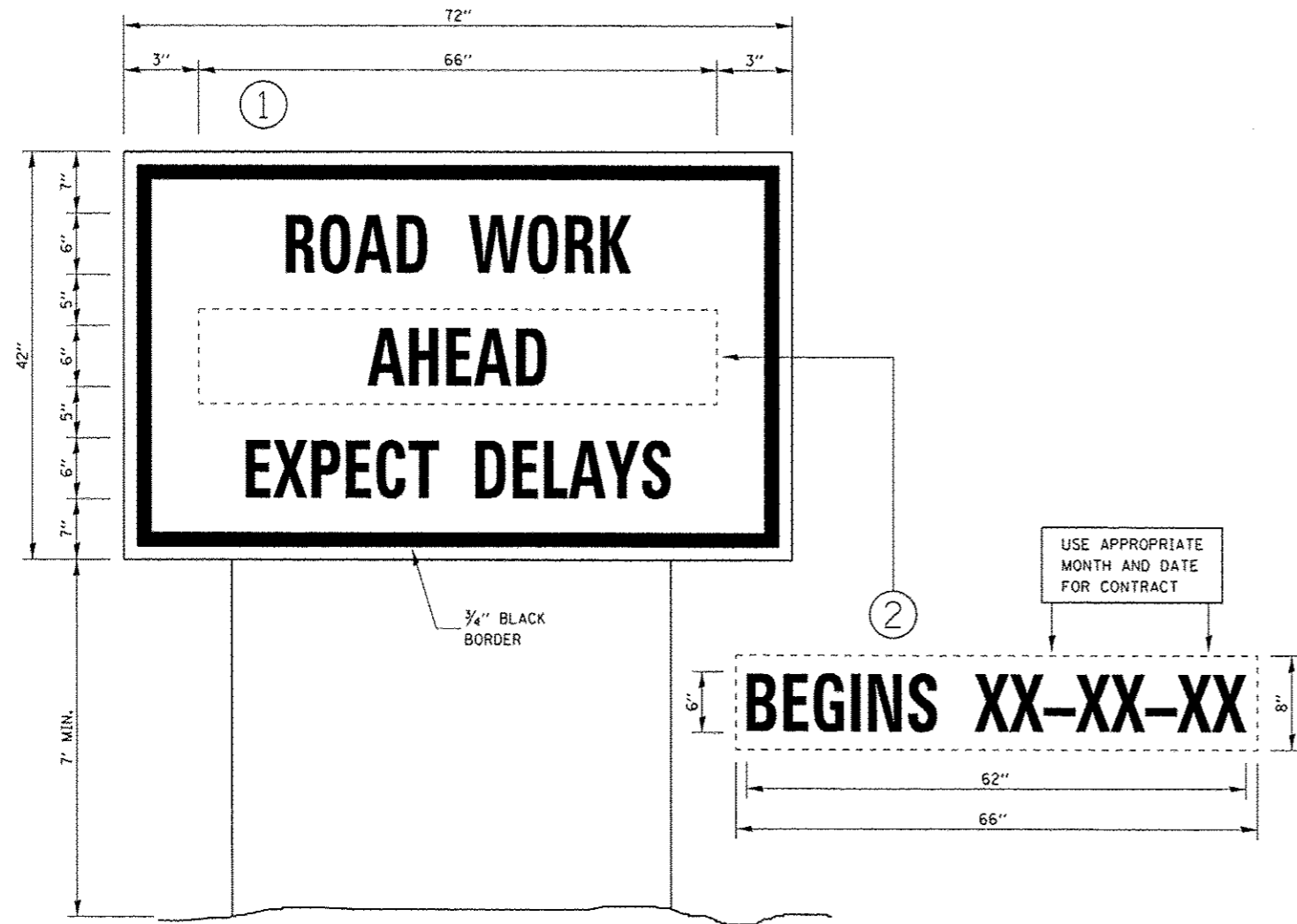

TEMPORARY INFORMATION SIGNING

NOTES:

1. USE 6" O BLACK LETTERING ON FLOURESENT ORANGE BACKGROUND.
2. ERECT SIGNS AT LOCATIONS IN ADVANCE OF THE "ROAD CONSTRUCTION AHEAD" SIGNS AS DIRECTED BY THE ENGINEER.
3. ERECT SIGN ① WITH INSTALLED PANEL ② A MINIMUM OF ONE WEEK PRIOR TO THE START OF THE LANE CLOSURE.
4. REMOVE PANEL ② ON THAT DATE.
5. SEE SPECIAL PROVISION "TEMPORARY INFORMATION SIGNING" FOR ADDITIONAL INFORMATION.
6. WILL BE PAID FOR PER SQ FT AS "TEMPORARY INFORMATION SIGNING". EACH SIGN = 21 SQ FT AND THE DATE PANEL ② WILL NOT BE MEASURED SEPARATELY FOR PAYMENT.

FILE NAME :	USER NAME :	DESIGNED :	REVISED :	STATE OF ILLINOIS DEPARTMENT OF TRANSPORTATION	TEMPORARY SIGNING	F.A.P. RTE.	SECTION	COUNTY	TOTAL SHEETS	SHEET NO.	
c:\pwwork\p1dot\woodshank\140380312	woodshank.r	RON WOODSHANK	-			697	(27-1H8-2)R	FORD	27	10	
	366074-shc-details.dgn	DRAWN :	REVISED :			SCALE: _____ SHEET NO. 1 OF 1 SHEETS STA. _____ TO STA. _____		CONTRACT NO. 66074			
	PLOT SCALE = 100.00' / 1"	CHECKED :	REVISED :			ILLINOIS FED. AID PROJECT					
	PLOT DATE = 5/19/2014	DATE :	REVISED :								

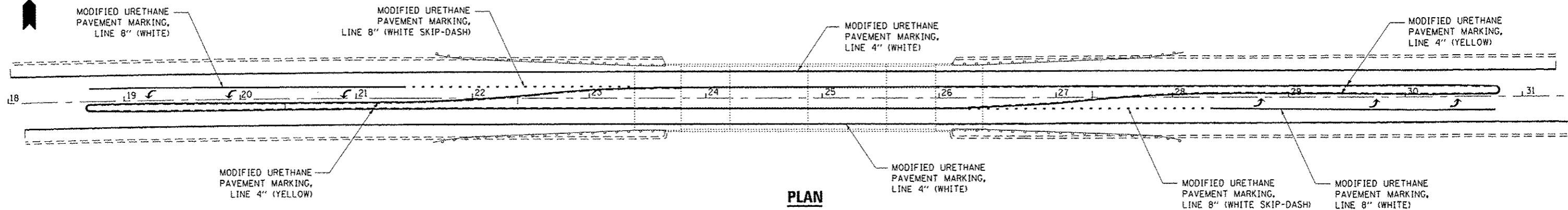

PLAN
PAVEMENT MARKING LIMITS

STA. 20+39 - STA. 23+78 LT & RT
STA. 25+97 - STA. 30+77 LT & RT

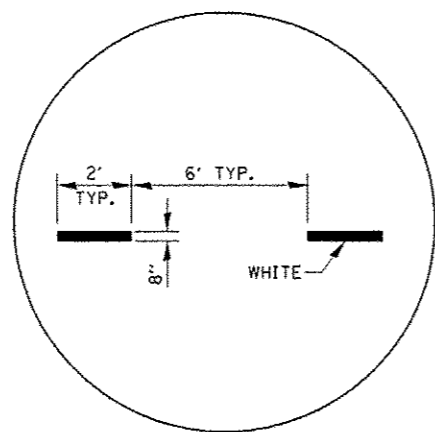

**ADVANCE AND INTERSECTION LANE
DIVIDER LINES**

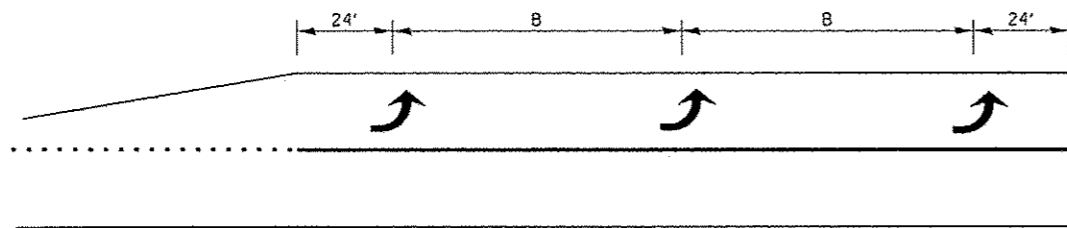

150' AND LONGER

**TYPICAL PLACEMENT OF ARROWS
IN TURN LANES**

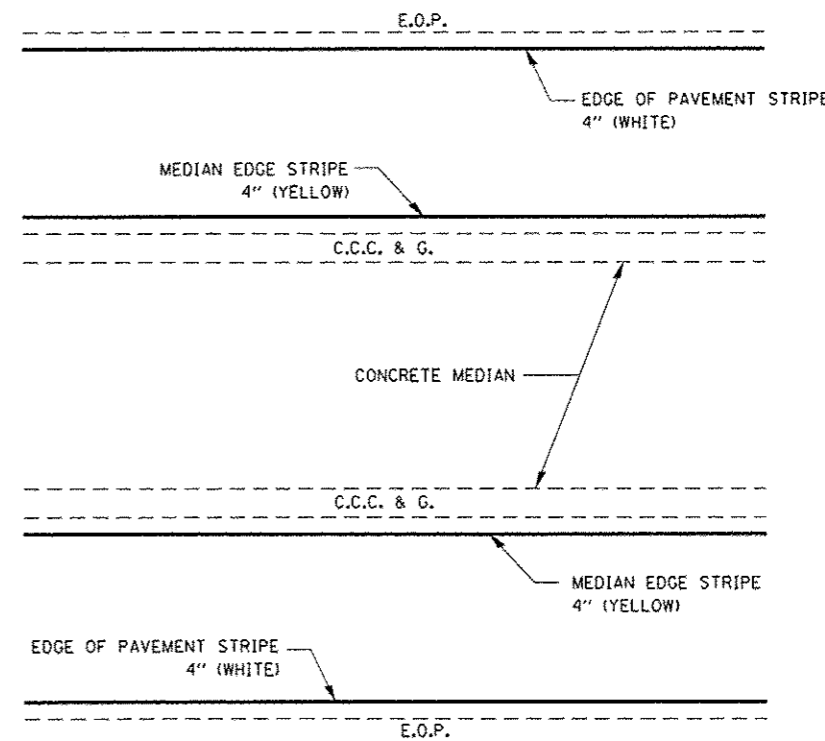

TYPICAL PAVEMENT MARKINGS

FILE NAME : c:\pwwork\pwwork\woodshankr\02360312	USER NAME : woodshankr	DESIGNED - RON WOODSHANK	REVISED -	STATE OF ILLINOIS DEPARTMENT OF TRANSPORTATION	PAVEMENT MARKINGS		F.A.P. RTE. 69T	SECTION (27-1HB-2)JR	COUNTY FORD	TOTAL SHEETS 27	SHEET NO. 11
	PLT SCALE = 100.00' / 1" =	CHECKED - YODESH PATEL	REVISED -				SCALE: _____	SHEET NO. 1 OF 1 SHEETS	STA. _____ TO STA. _____	CONTRACT NO. 66074	
PLT DATE = 5/19/2014	DATE = 2/10/2014	REVISED -	REVISED -								

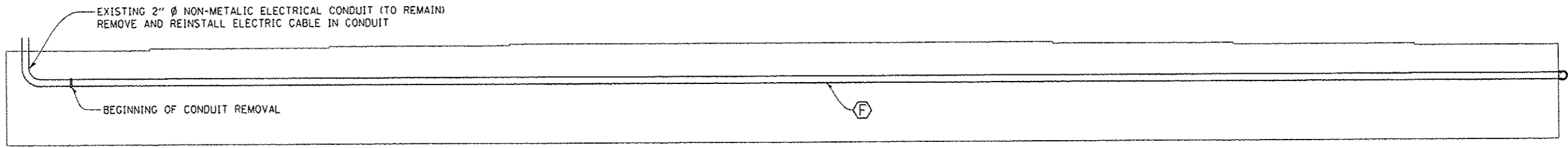

ELEVATION
AT W. ABUT.

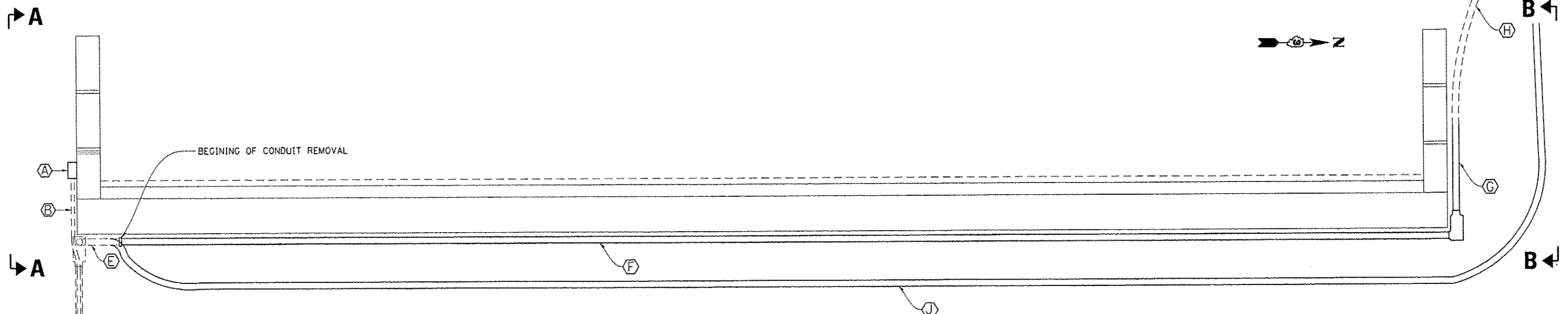

PLAN
AT W. ABUT.

- (A) REMOVE AND REPLACE JUNCTION BOX (RE-SPLICE EXISTING ELECTRICAL WIRE)
- (B) REMOVE AND REINSTALL EXISTING FLEXIBLE ELECTRICAL CONDUIT
1) REMOVE AND REPLACE CONNECTION FITTINGS
2) REMOVE AND REINSTALL EXISTING WIRE (EXISTING WIRE SHALL BE COILED AND PROTECTED FROM WEATHER CONDITIONS DURING ABUT. RECONSTRUCTION)
- (C) EXISTING 1" Ø GALVANIZED ELECTRICAL CONDUIT (TO REMAIN IN PLACE)
- (D) EXISTING 2" Ø ELECTRICAL CONDUIT (TO REMAIN IN PLACE)
1) REMOVE AND REPLACE ELECTRICAL CABLE IN CONDUIT
- (E) EXISTING 2" Ø FLEXIBLE ELECTRICAL CONDUIT (TO REMAIN IN PLACE)
REMOVE ELECTRICAL CABLE FROM CONDUIT
- (F) REMOVE AND REPLACE 2" Ø GALVANIZED ELECTRICAL CONDUIT
REMOVE AND REPLACE ELECTRICAL CABLE IN CONDUIT
- (G) REMOVE AND REPLACE 10' OF 2" Ø GALVANIZED ELECTRICAL CONDUIT
REMOVE AND REPLACE ELECTRICAL CABLE IN CONDUIT
THIS WORK SHALL BE INCLUDED IN THE COST OF THE CONDUIT ATTACHED TO STRUCTURE ITEMS.
- (H) REMOVE AND REPLACE ELECTRICAL CABLE IN CONDUIT
- (J) "MAINTAINING EXISTING LIGHTING SYSTEM"
1) INSTALLATION AND REMOVAL OF 2" Ø FLEXIBLE NON-METALIC ELECTRICAL CONDUIT
2) INSTALLATION AND REMOVAL OF "EXISTING" ELECTRICAL CABLE

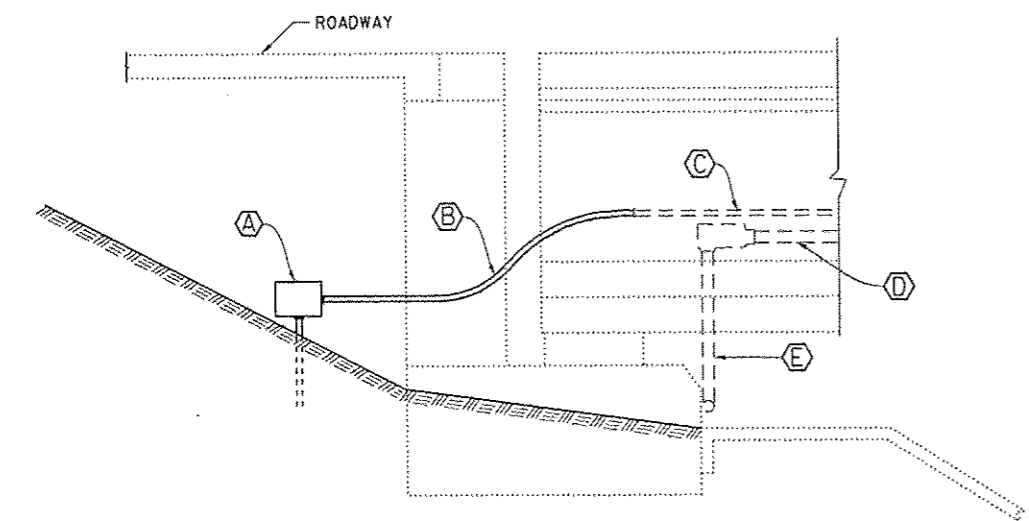

VIEW A-A
AT SW CORNER
(W. ABUT.)

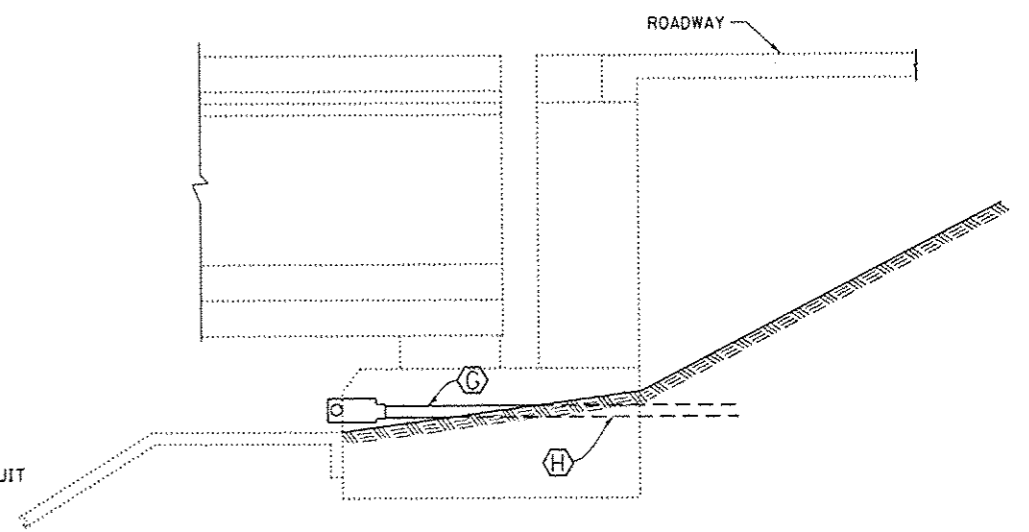

VIEW B-B
AT NW CORNER
(W. ABUT.)

FILE NAME :	USER NAME : woodshankr1	DESIGNED - RON WOODSHANK	REVISED - RW 4/15/2014	STATE OF ILLINOIS DEPARTMENT OF TRANSPORTATION	ELECTRICAL DETAILS	F.A.P. RTE. 697	SECTION (27-1HB-2)IR	COUNTY FORD	TOTAL SHEETS 27	SHEET NO. 12	
os:\pwwork\p-jstos\woodshankr1\d0368312\366074-sht-details.dgn	DRAWN - RON WOODSHANK	REVISED -	SCALE: _____			SHEET NO. 1 OF 1 SHEETS	STA. _____ TO STA. _____	CONTRACT NO. 66D74		ILLINOIS FED. AID PROJECT	
PLOT SCALE = 100.00 1/2 in.	CHECKED - YOGESH PATEL	REVISED -									
PLOT DATE = 5/19/2014	DATE - 2/10/2014	REVISED -									

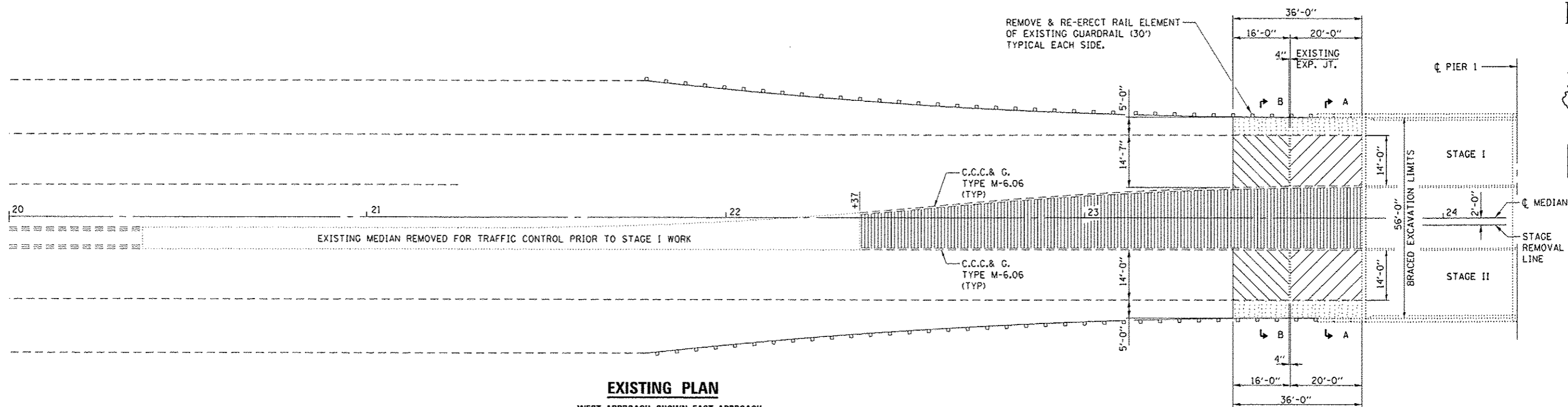

EXISTING PLAN

WEST APPROACH SHOWN, EAST APPROACH
SIMILAR THRU 180 DEG. ROTATION
ABOUT CENTERLINE OF STRUCTURE

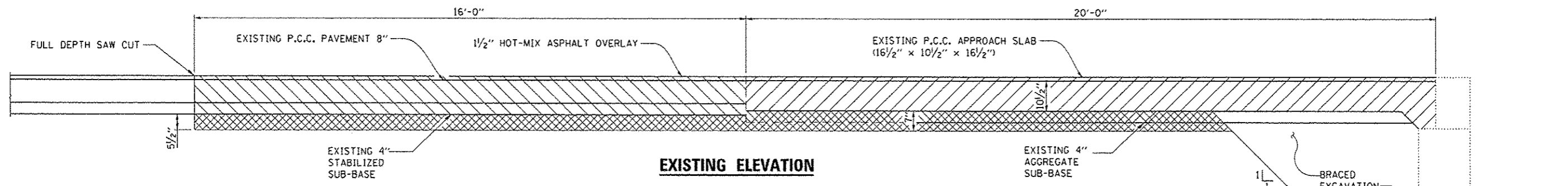

EXISTING ELEVATION

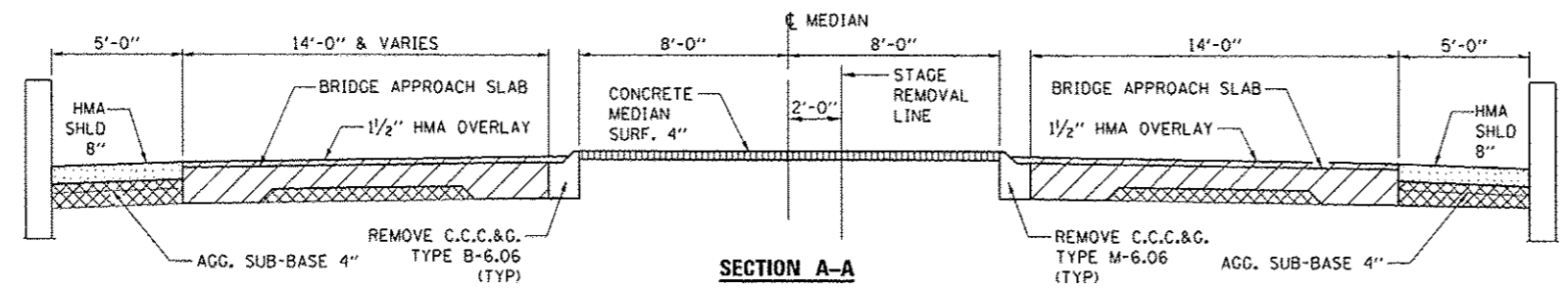

SECTION A-A

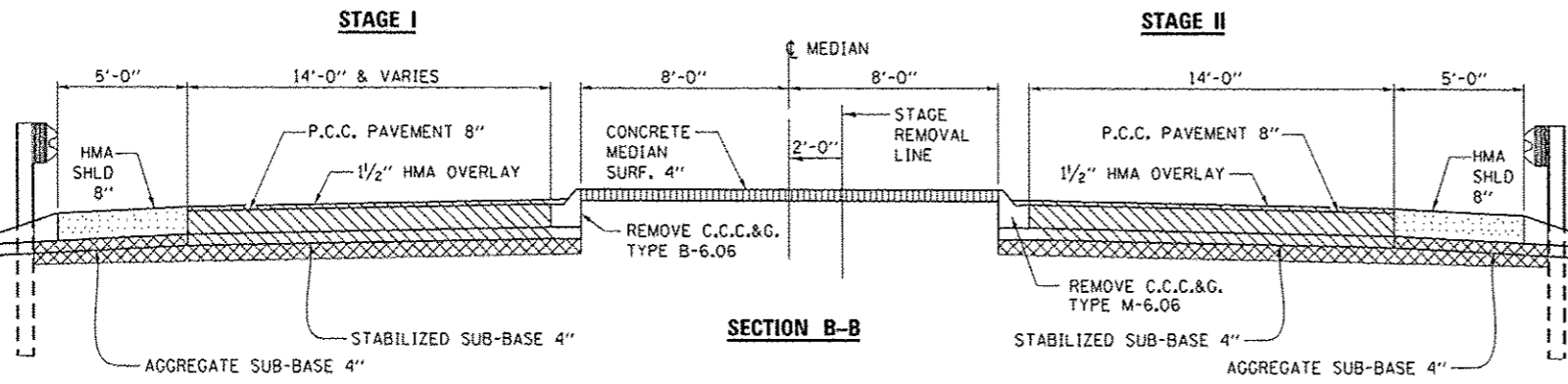

SECTION B-B

LEGEND

- APPROACH SLAB REMOVAL
- PAVEMENT REMOVAL
- PAVED SHOULDER REMOVAL
- EARTH EXCAVATION
- CONCRETE MEDIAN SURFACE REMOVAL

FILE NAME :	USER NAME : woodshankr1	DESIGNED - RON WOODSHANK	REVISED - RLW 4/15/2014
c:\pwork\pwork\woodshankr1\09300312\	366074-shd-detailed.dgn	DRAWN - RON WOODSHANK	REVISED -
	PLOT SCALE = 100.00' / IN.	CHECKED - YOGESH PATEL	REVISED -
	PLOT DATE = 5/19/2014	DATE - 2/10/2014	REVISED -

STATE OF ILLINOIS
DEPARTMENT OF TRANSPORTATION

**EXISTING PLAN AND ELEVATION
ROADWAY APPROACH PAVEMENT REMOVAL**

SCALE: _____ SHEET NO. 1 OF 1 SHEETS STA. _____ TO STA. _____

F.A.P. RTE.	SECTION	COUNTY	TOTAL SHEETS	SHEET NO.
697	(27-1HB-2)HR	FORD	27	13
			CONTRACT NO. 66D74	
ILLINOIS FED. AID PROJECT				

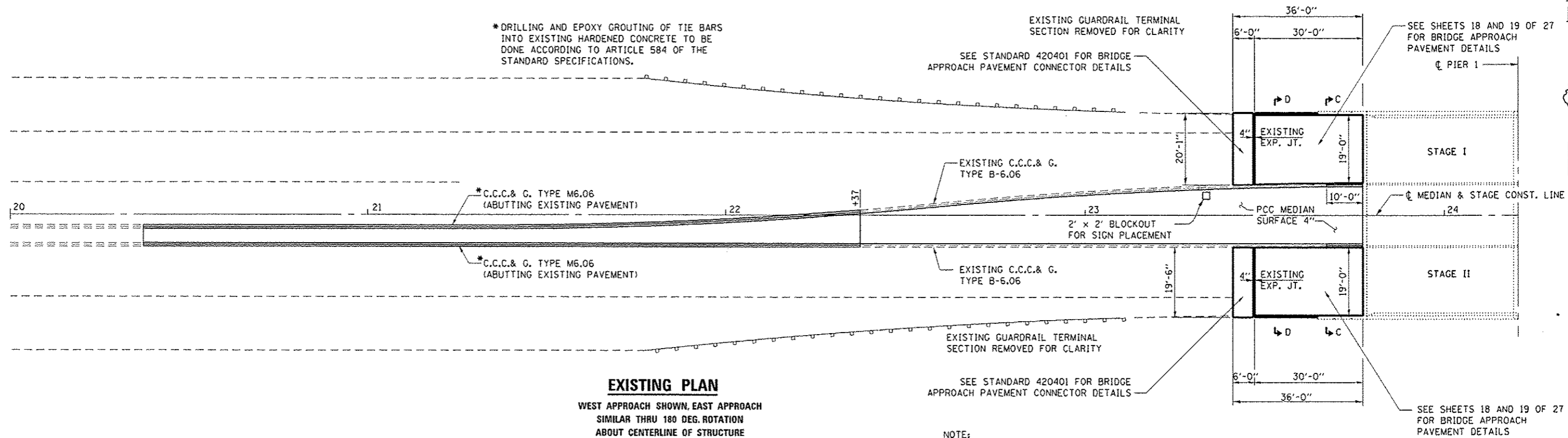

*DRILLING AND EPOXY GROUTING OF TIE BARS INTO EXISTING HARDENED CONCRETE TO BE DONE ACCORDING TO ARTICLE 584 OF THE STANDARD SPECIFICATIONS.

EXISTING GUARDRAIL TERMINAL SECTION REMOVED FOR CLARITY
SEE STANDARD 420401 FOR BRIDGE APPROACH PAVEMENT CONNECTOR DETAILS

SEE SHEETS 18 AND 19 OF 27 FOR BRIDGE APPROACH PAVEMENT DETAILS
Pier 1

*C.C.C. & G. TYPE M6.06 (ABUTTING EXISTING PAVEMENT)

EXISTING C.C.C. & G. TYPE B-6.06

STAGE I

*C.C.C. & G. TYPE M6.06 (ABUTTING EXISTING PAVEMENT)

EXISTING C.C.C. & G. TYPE B-6.06

STAGE II

EXISTING PLAN

WEST APPROACH SHOWN, EAST APPROACH SIMILAR THRU 180 DEG. ROTATION ABOUT CENTERLINE OF STRUCTURE

SEE STANDARD 420401 FOR BRIDGE APPROACH PAVEMENT CONNECTOR DETAILS

NOTE: EXACT PLACEMENT OF THE 2' x 2' BLOCKOUTS FOR SIGN PLACEMENT SHALL BE DETERMINED IN THE FIELD BY THE ENGINEER. COST INCLUDED WITH CONCRETE MEDIAN SURFACE.

SEE SHEETS 18 AND 19 OF 27 FOR BRIDGE APPROACH PAVEMENT DETAILS

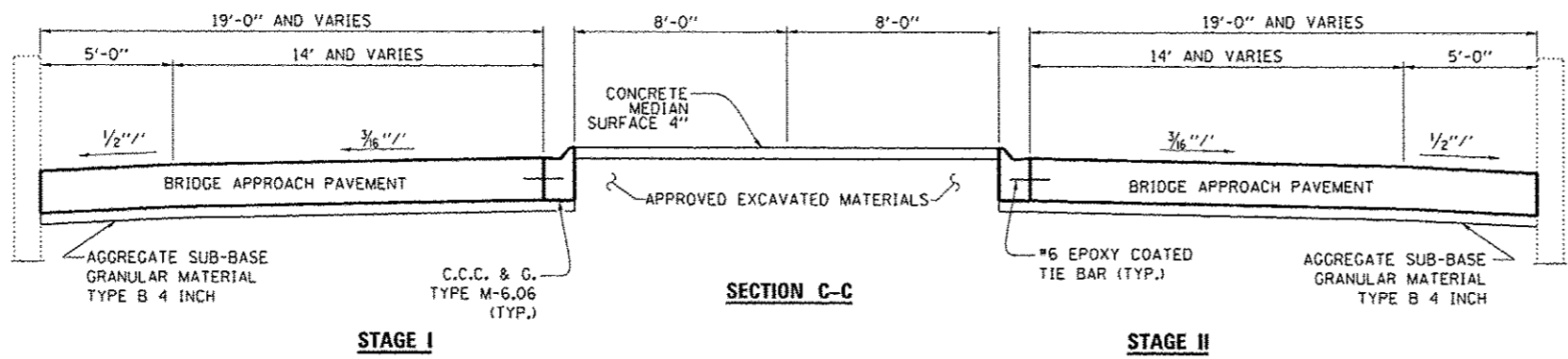

SECTION C-C

STAGE I

STAGE II

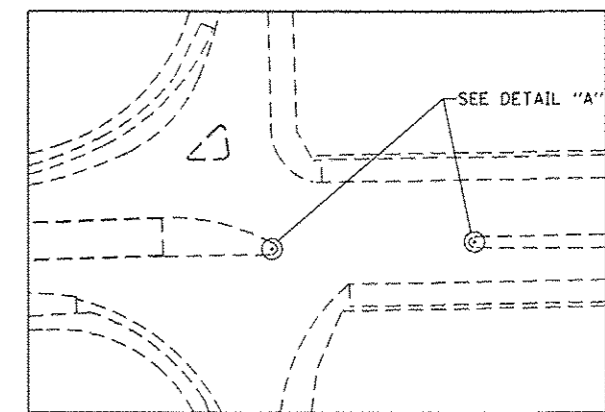

FLEXIBLE DELINEATORS AT MEDIAN NOSES

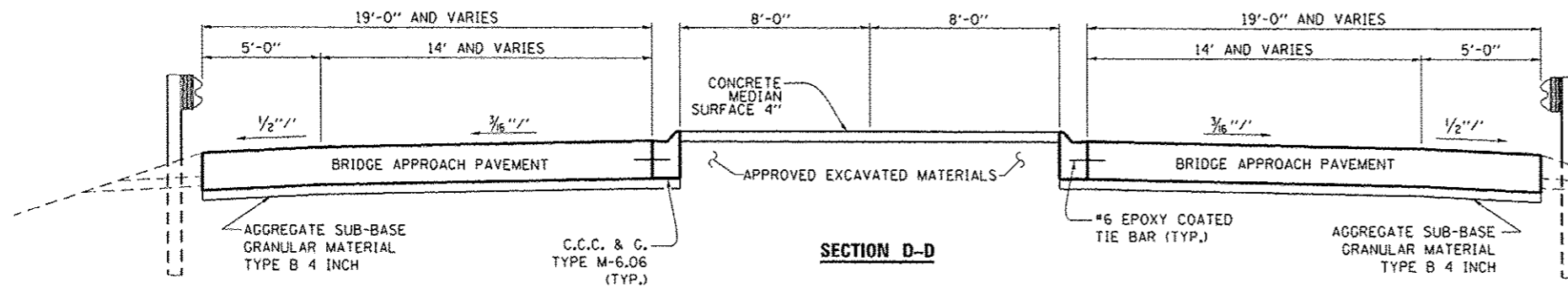

SECTION D-D

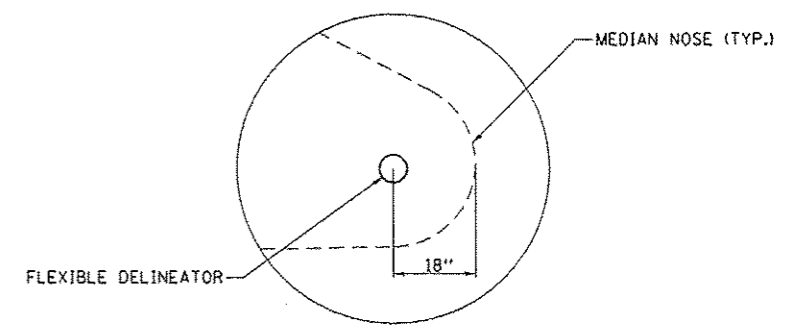

DETAIL "A"

FILE NAME =	USER NAME = woodshankr1	DESIGNED - RON WOODSHANK	REVISED - RLW 4/15/2014	STATE OF ILLINOIS DEPARTMENT OF TRANSPORTATION	PROPOSED PLAN AND ELEVATION ROADWAY APPROACH PAVEMENT RECONSTRUCTION	F.A.P. RTE. 697	SECTION (27-1HB-2)IR	COUNTY FORD	TOTAL SHEETS 27	SHEET NO. 14		
ct:\pwork\pwork\woodshankr1\ad380312\	366074-shr-data\1a.dgn	DRAWN - RON WOODSHANK	REVISED -			SCALE: _____	SHEET NO. 1 OF 1 SHEETS	STA. _____ TO STA. _____	CONTRACT NO. 66D74		ILLINOIS FED. AID PROJECT	
PLOT SCALE = 1/8" = 1'-0"	CHECKED - YOGESH PATEL	DATE - 2/10/2014	REVISED -									
PLOT DATE = 5/19/2014			REVISED -									

GENERAL NOTES

ALL STRUCTURAL STEEL SHALL CONFORM TO AASHTO CLASSIFICATION M-270 GR. 36, UNLESS OTHERWISE NOTED.

PLAN DIMENSIONS AND DETAILS RELATIVE TO EXISTING PLANS ARE SUBJECT TO NOMINAL CONSTRUCTION VARIATIONS. THE CONTRACTOR SHALL FIELD VERIFY EXISTING DIMENSIONS AND DETAILS AFFECTING NEW CONSTRUCTION AND MAKE NECESSARY APPROVED ADJUSTMENTS PRIOR TO CONSTRUCTION OR ORDERING OF MATERIALS. SUCH VARIATIONS SHALL NOT BE CAUSE FOR ADDITIONAL COMPENSATION FOR A CHANGE IN SCOPE OF THE WORK, HOWEVER, THE CONTRACTOR WILL BE PAID FOR THE QUANTITY ACTUALLY FURNISHED AT THE UNIT PRICE BID FOR THE WORK.

REINFORCEMENT BARS DESIGNATED (E) SHALL BE EPOXY COATED.

THE DECK SURFACE SHALL HAVE ITS FINAL FINISH TINED ACCORDING TO ARTICLE 420.09(a)(1) OF THE STANDARD SPECIFICATIONS. COST INCLUDED WITH CONCRETE SUPERSTRUCTURES.

JOINT PLATES AND ATTACHED BARS SHALL BE SHOP PAINTED WITH THE INORGANIC ZINC RICH PRIMER. NO FIELD PAINT REQUIRED.

EXISTING REINFORCEMENT BARS EXTENDING INTO THE REMOVAL AREA SHALL BE CLEANED, STRAIGHTENED AND INCORPORATED INTO THE NEW CONSTRUCTION. ANY REINFORCEMENT BARS THAT ARE DAMAGED DURING CONCRETE REMOVAL SHALL BE REPLACED WITH AN APPROVED BAR SPLICER OR ANCHORAGE SYSTEM. COST INCLUDED WITH CONCRETE REMOVAL.

JOINT OPENINGS SHALL BE ADJUSTED ACCORDING TO ARTICLE 520.04 OF THE STD. SPECS. WHEN THE DECK IS POURED AT AN AMBIENT TEMPERATURE OTHER THAN 50° F.

PROTECTIVE COAT SHALL BE PLACED ON "ALL" NEWLY PLACED CONCRETE SURFACES OF THE APPROACH SLABS, ABUT. BLOCK OUTS, DECK, INCLUDING MEDIAN SURFACES, INSIDE SURFACES OF THE PARAPET AND WING WALLS.

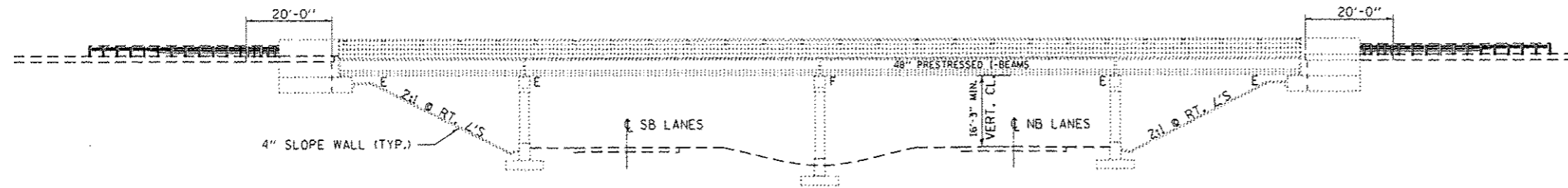

ELEVATION

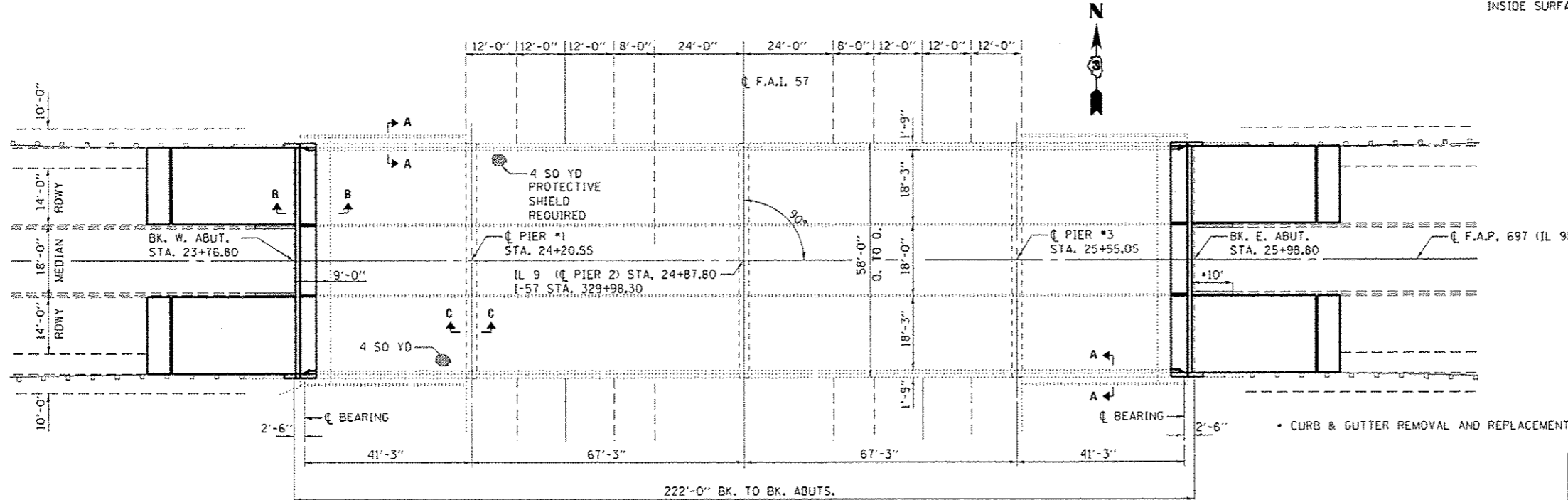

**PLAN
STRUCTURE NO. 027-0010**

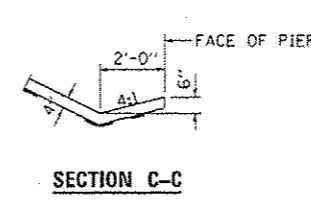
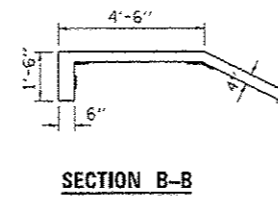
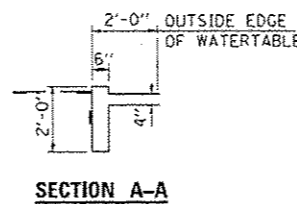

SLOPEWALL SECTIONS



TOTAL BILL OF MATERIAL

ITEM	UNIT	QUANTITY
CONCRETE REMOVAL	CU YD	57.8
CONCRETE STRUCTURES	CU YD	57.2
CONCRETE SUPERSTRUCTURE	CU YD	133.6
PROTECTIVE COAT	SO YD	1304
REINFORCEMENT BARS, EPOXY COATED	POUND	39440
BAR SPLICERS	EACH	16
BAR SPLICERS, SPECIAL	EACH	8
MECHANICAL SPLICERS	EACH	236
PREFORMED JOINT STRIP SEAL	FOOT	114
POLYMER MODIFIED PORTLAND CEMENT MORTAR	SO FT	98
REMOVE AND RE-ERECT EXISTING BRIDGE RAIL	FOOT	40
BRACED EXCAVATION	CU YD	66
GRANULAR BACKFILL FOR STRUCTURES	CU YD	66
DECK SLAB REPAIR (FULL DEPTH, TYPE II)	SO YD	8
STRUCTURAL REPAIR OF CONCRETE (DEPTH EQUAL TO OR LESS THAN 5")	EACH	31
PROTECTIVE SHIELD	SO YD	4



David Carl Puzey 6/30/14
Expires 11/30/14

FILE NAME =	USER NAME = woodshankr1	DESIGNED - RON WOODSHANK	REVISED - 6/21/2014	STATE OF ILLINOIS DEPARTMENT OF TRANSPORTATION	EXISTING PLAN AND ELEVATION FOR STRUCTURE NO. 027-0010	F.A.P. RTE. 697	SECTION (27-1HB-21)R	COUNTY FORD	TOTAL SHEETS 27	SHEET NO. 15
CONTRACT NO. 66074	ILLINOIS FID. AID PROJECT	SCALE: _____	SHEET NO. 1 OF 13 SHEETS			STA. 23+76.80 TO STA. 25+98.80				
PLOT DATE = 6/21/2014	CHECKED - YOGESH PATEL	DATE - 2/10/2014	REVISED -							
PLOT SCALE = 1/8" = 1' / in.	DRAWN - RON WOODSHANK	REVISED -								

NOTES

THE CONTRACTOR SHALL USE EXTREME CARE DURING CONCRETE REMOVAL SO AS NOT TO DAMAGE THE PPC I-BEAM.

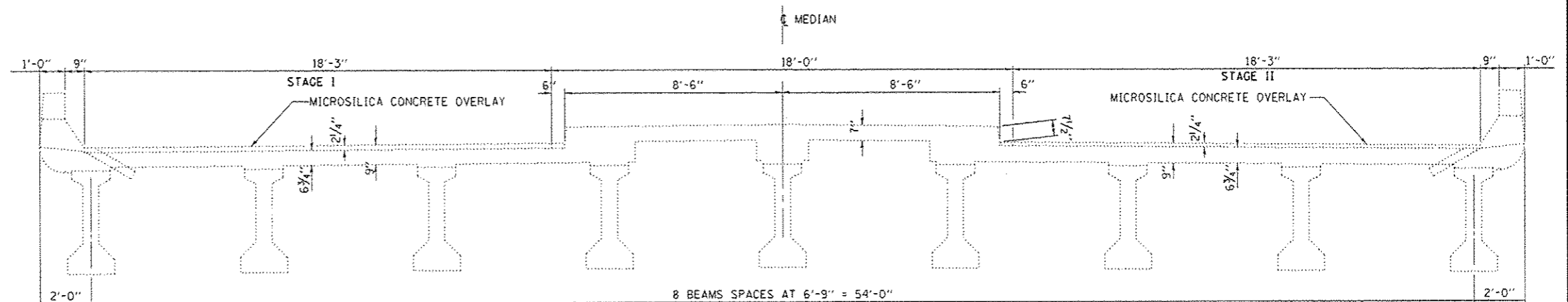
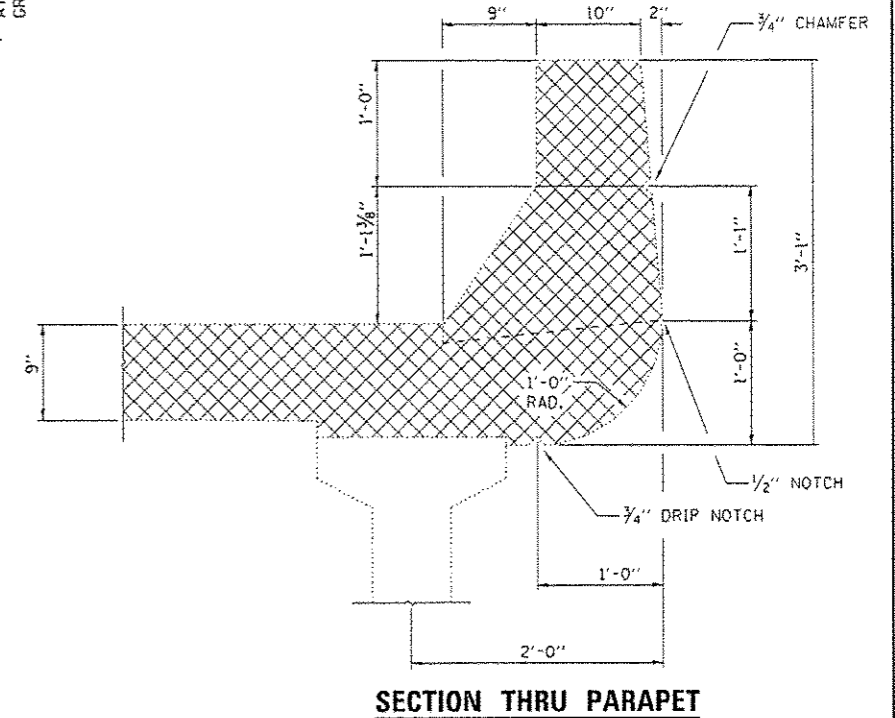
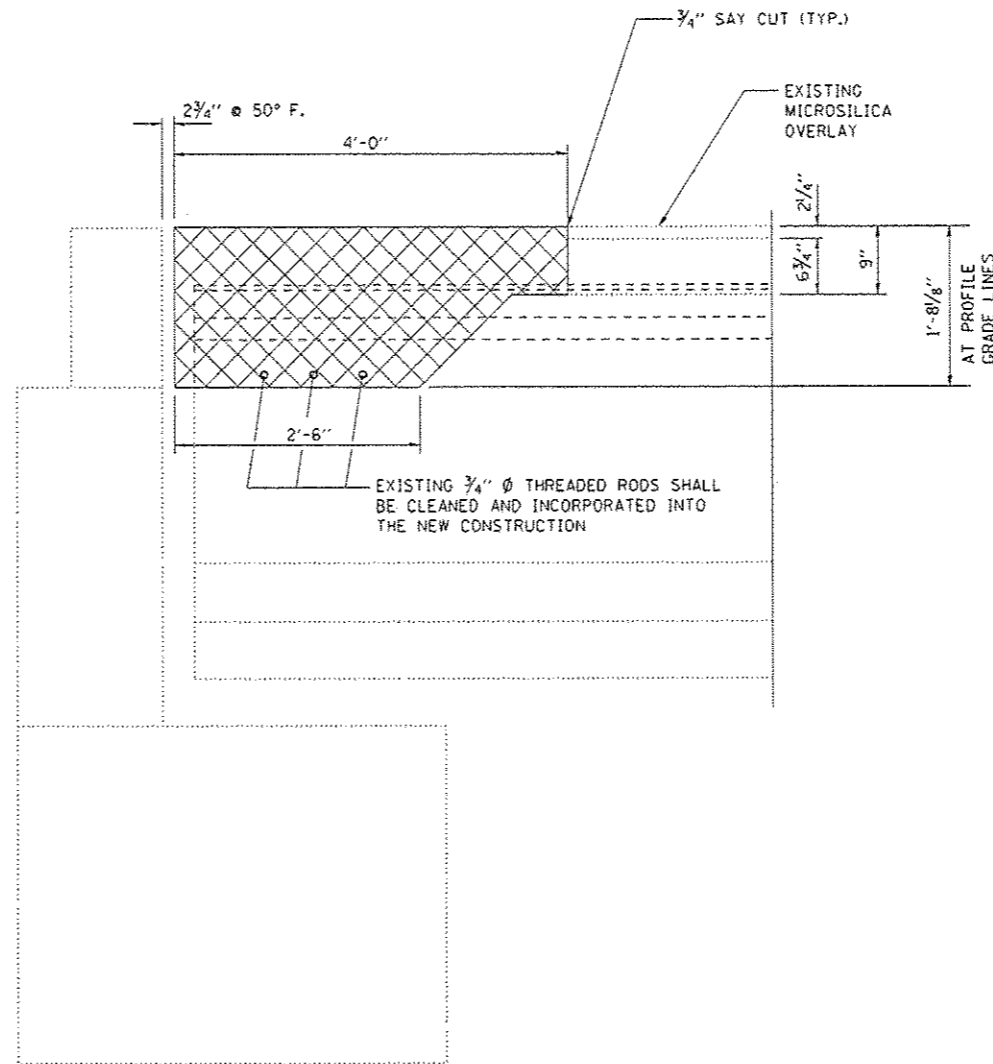
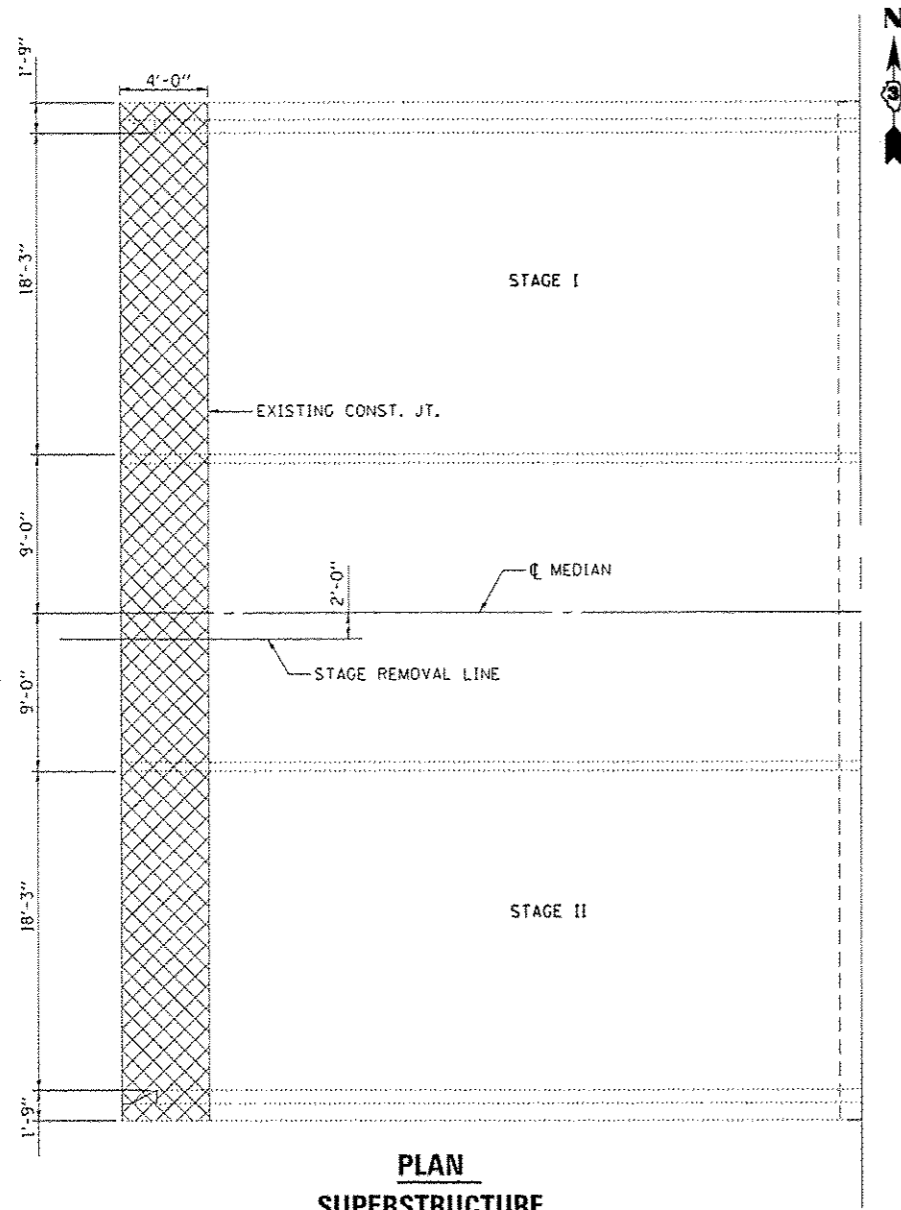

CONCRETE REMOVAL

FILE NAME =	USER NAME = woodshankr1	DESIGNED - RON WOODSHANK	REVISED - 6/21/2014
c:\pvc\work\p1\dot\woodshankr1\02380312\	366074-eh1-details.dgn	DRAWN - RON WOODSHANK	REVISED -
	PLOT SCALE = 100.00 1/ 1in.	CHECKED - YOGESH PATEL	REVISED -
	PLOT DATE = 6/21/2014	DATE - 2/10/2014	REVISED -

STATE OF ILLINOIS
DEPARTMENT OF TRANSPORTATION

**SUPERSTRUCTURE REMOVAL DETAILS
FOR STRUCTURE NO. 027-0010**

SCALE: _____ SHEET NO. 2 OF 13 SHEETS STA. _____ TO STA. _____

F.A.P. RT#	SECTION	COUNTY	TOTAL SHEETS	SHEET NO.
697	(27-1HB-2)IR	FORD	27	16
CONTRACT NO. 66074			ILLINOIS FED. AID PROJECT	

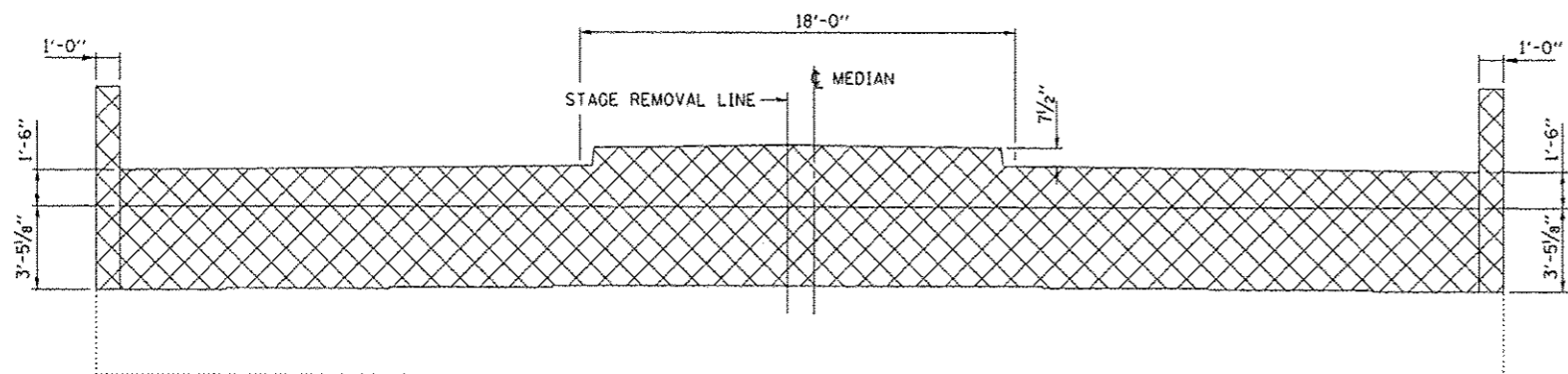

**ELEVATION
AT ABUTMENT**
LOOKING WEST

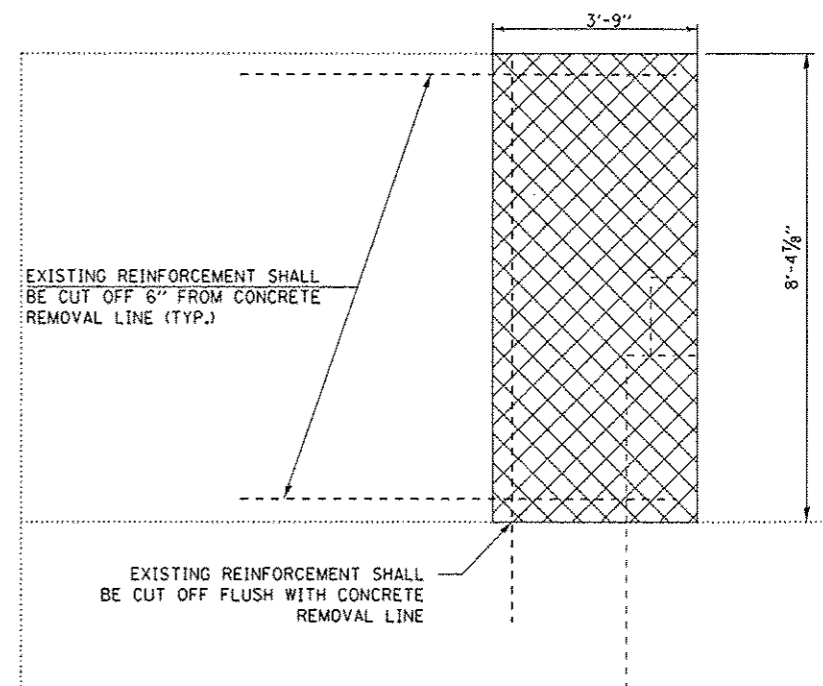

WING WALL ELEVATION

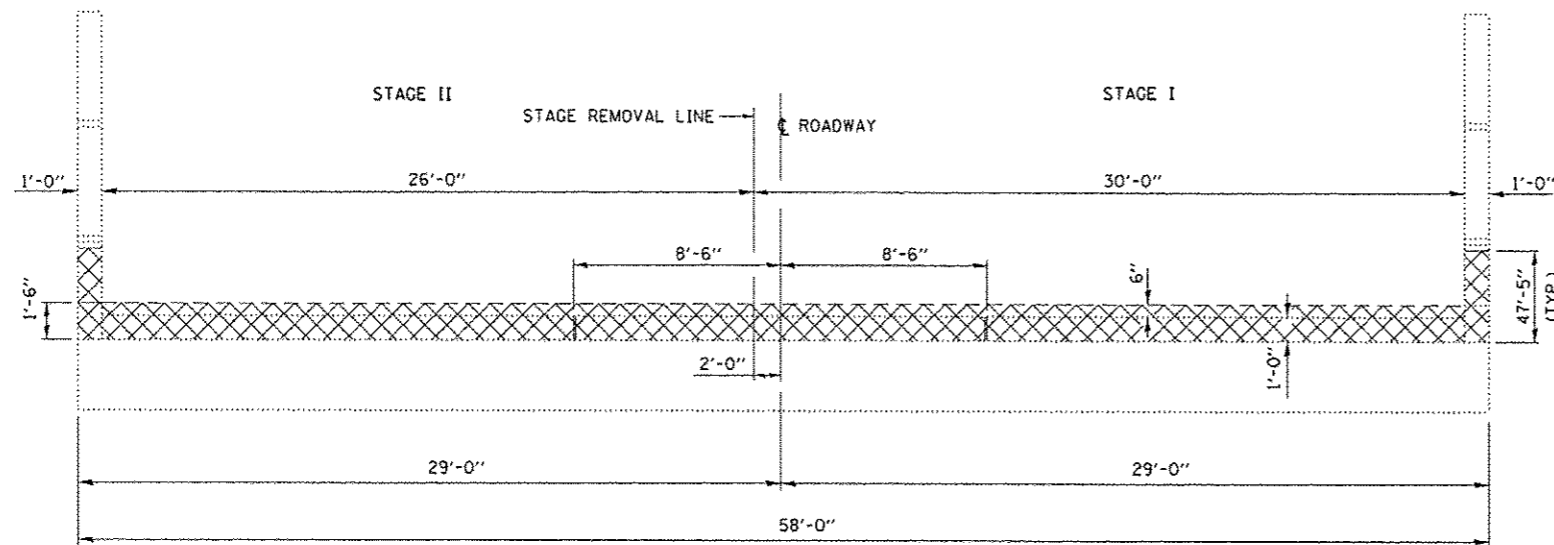

**PLAN
AT ABUTMENT**
WEST ABUT. SHOWN, EAST ABUT.
SIMILAR THRU 180 DEG. ROTATION
ABOUT CENTERLINE OF STRUCTURE

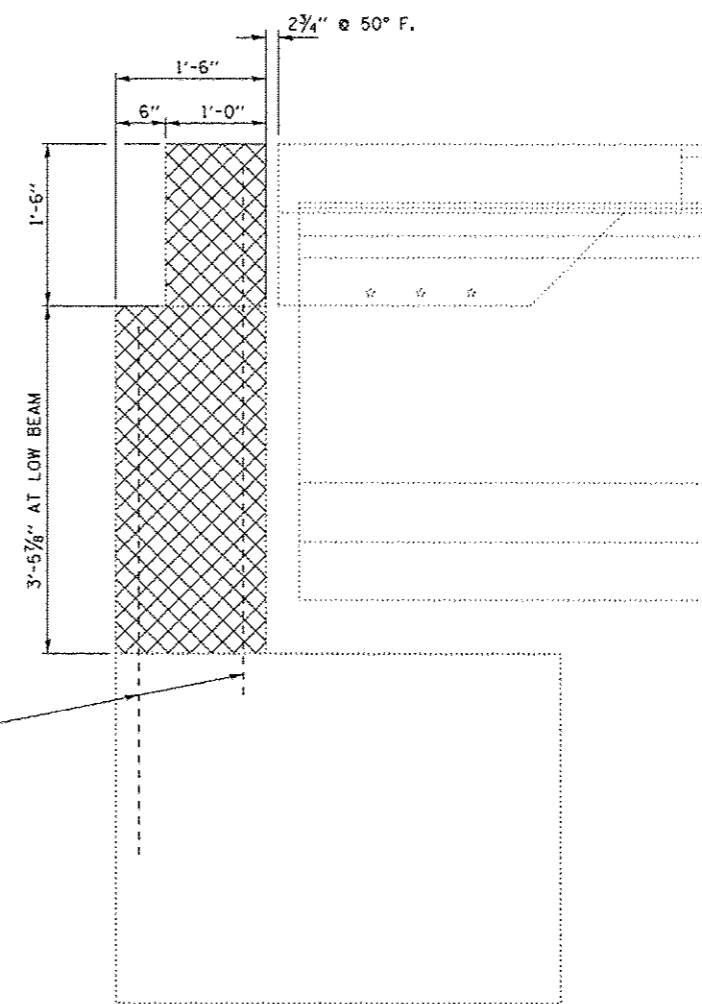

SECTION THRU ABUTMENT

FILE NAME :	USER NAME :	DESIGNED :	REVISED :
c:\pwork\pwork\woodshankr\140380312\0366074-shi-details.dgn	woodshankr	RON WOODSHANK	-
PLOT SCALE = 100.00' / 1"	CHECKED :	RON WOODSHANK	REVISED :
PLOT DATE = 5/19/2014	YOGESH PATEL	2/10/2014	-

STATE OF ILLINOIS
DEPARTMENT OF TRANSPORTATION

ABUTMENT REMOVAL DETAILS
FOR STRUCTURE NO. 027-0010

SCALE: _____ SHEET NO. 3 OF 13 SHEETS STA. _____ TO STA. _____

F.A.P. RTE.	SECTION	COUNTY	TOTAL SHEETS	SHEET NO.
697	(27-1HB-2)R	FORD	27	17
			CONTRACT NO. 66074	
ILLINOIS FED. AID PROJECT				

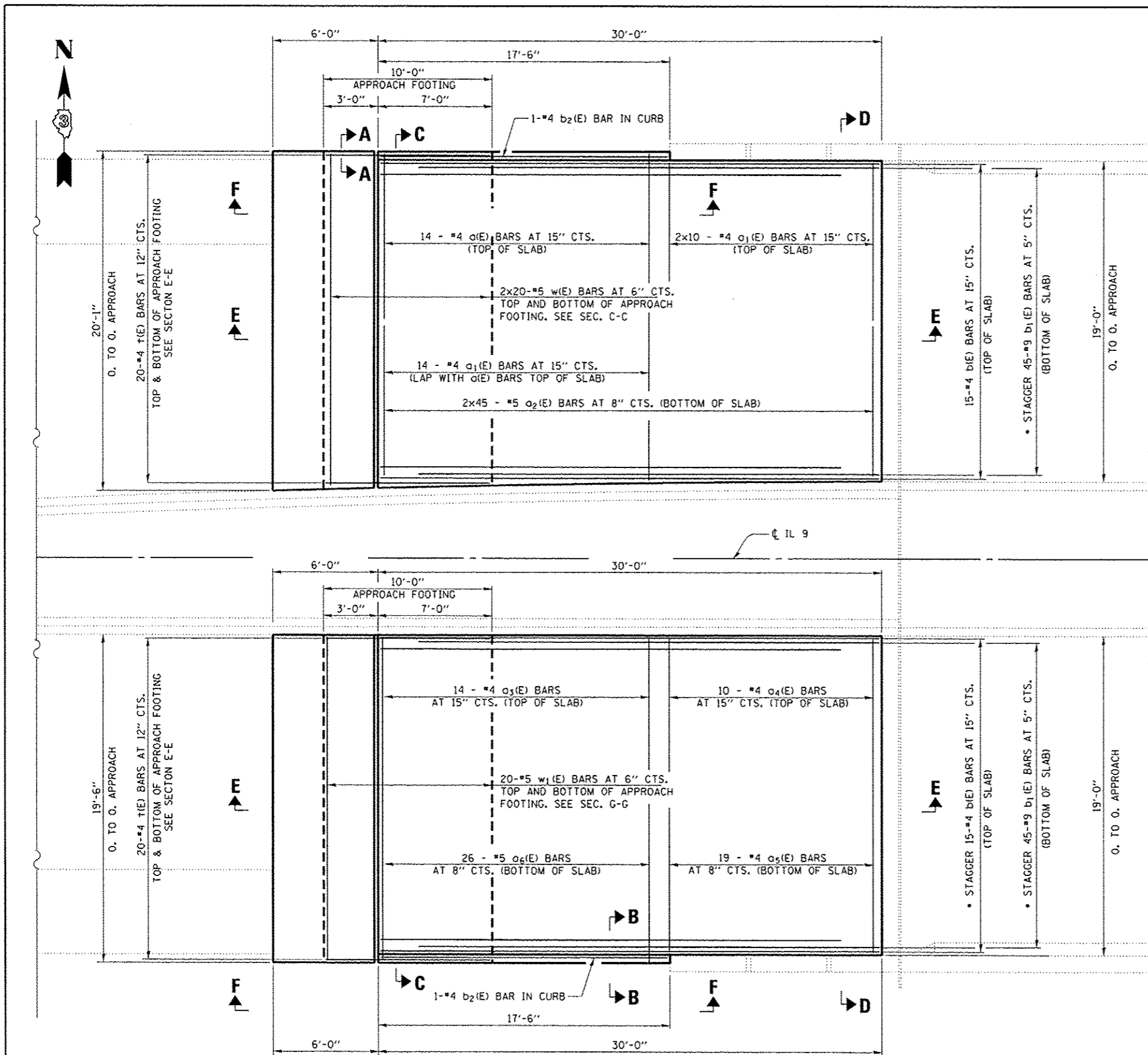

**PLAN
SUPERSTRUCTURE**
WEST ABUT. SHOWN.
EAST ABUT. SIMILAR THRU 180 DEG. ROTATION
ABOUT CENTERLINE OF STRUCTURE

NOTES:
SEE SHEET 19 OF 27 FOR SECTIONS E-E, F-F, G-G AND VIEW H-H.
 $\alpha_2(E)$ AND $\alpha_3(E)$ BAR SPACINGS MEASURED ALONG ϕ RDWY.
THE JOINT OPENING SHALL BE DETERMINED PER ARTICLE 520.04 EXCEPT THAT ON JOINTLESS STRUCTURES, THE DISTANCE DESCRIBED AS THE BRIDGE LENGTH BETWEEN THE NEAREST FIXED BEARINGS EACH WAY FROM THE JOINT SHALL BE TAKEN AS HALF THE BRIDGE LENGTH PLUS THE APPROACH SLAB LENGTH. THE MINIMUM DIMENSION SHALL BE $1\frac{1}{2}$ " FOR INSTALLATION PURPOSES.

*** COST INCLUDED WITH CONCRETE SUPERSTRUCTURE.

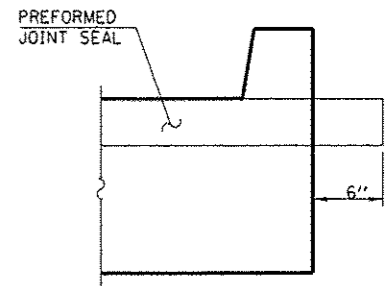

**VIEW A-A
TYPICAL**

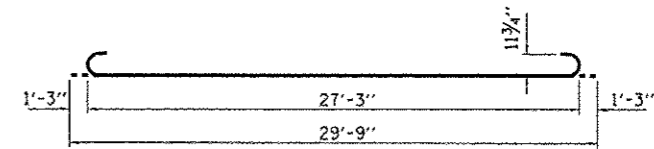

BAR $b_3(E)$

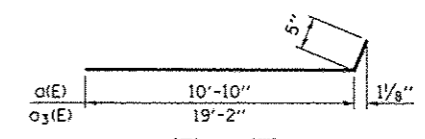

$a(E), a_3(E)$

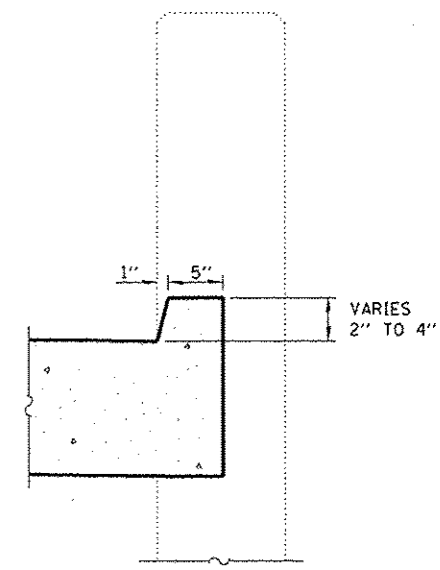

**VIEW B-B
TYPICAL**

FILE NAME : c:\pwwork\pwwork\woodshankr1\66074.dgn	USER NAME : woodshankr1	DESIGNED - RON WOODSHANK	REVISED - RW 4/15/2014
PLOT SCALE = 1/80.00	DATE = 5/19/2014	DRAWN - RON WOODSHANK	REVISED -
		CHECKED - YOGESH PATEL	REVISED -
		DATE - 2/10/2014	REVISED -

**STATE OF ILLINOIS
DEPARTMENT OF TRANSPORTATION**

**BRIDGE APPROACH PAVEMENT
RECONSTRUCTION**

F.A.P. RTE. 697	SECTION (27-1HB-2)JR	COUNTY FORD	TOTAL SHEETS 27	SHEET NO. 18
CONTRACT NO. 66D74				ILLINOIS FED. AID PROJECT

SCALE: _____ SHEET NO. 4 OF 13 SHEETS STA. _____ TO STA. _____

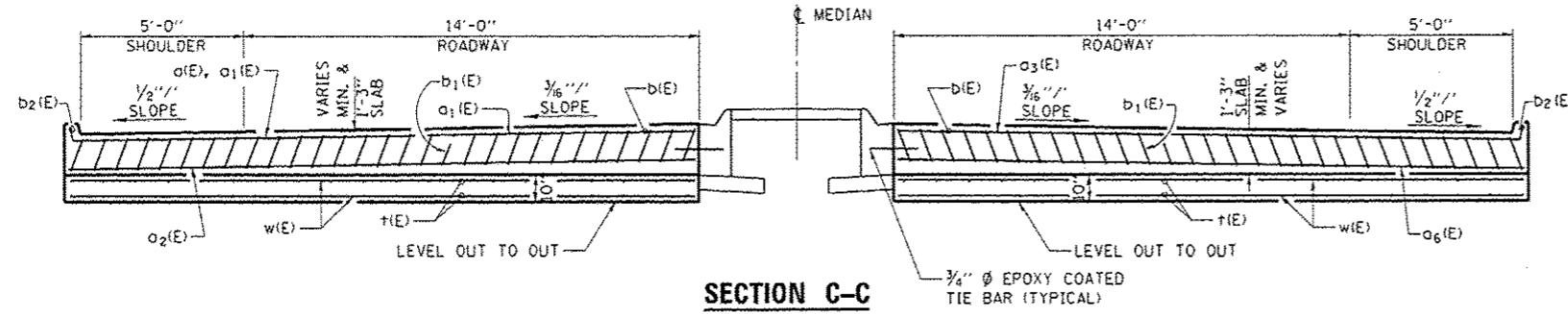

**SECTION C-C
AT APPROACH FOOTING**

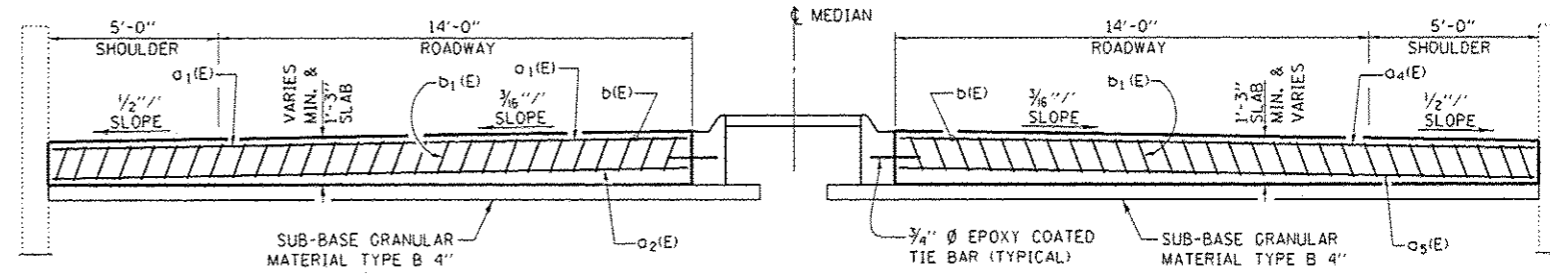

**SECTION D-D
NEAR ABUTMENT**

NOTES:
 APPROACH SLAB AND PARAPET CONCRETE SHALL BE PAID FOR AS CONCRETE SUPERSTRUCTURE.
 APPROACH FOOTING CONCRETE SHALL BE PAID FOR AS CONCRETE STRUCTURES.
 REINFORCEMENT SHALL BE PAID FOR AS REINFORCEMENT BARS, EPOXY COATED.
 FOR $v_3(E)$ BAR DETAILS, SEE SHEET 21 OF 27.
 THE APPROACH FOOTING MAXIMUM APPLIED SERVICE BEARING PRESSURE (OMAX) = 2.0 KSF.
 FOR BAR SPLICER DETAILS, SEE SHEET 22 OF 27.
 COST OF EXCAVATION FOR APPROACH FOOTING INCLUDED WITH CONCRETE STRUCTURES.

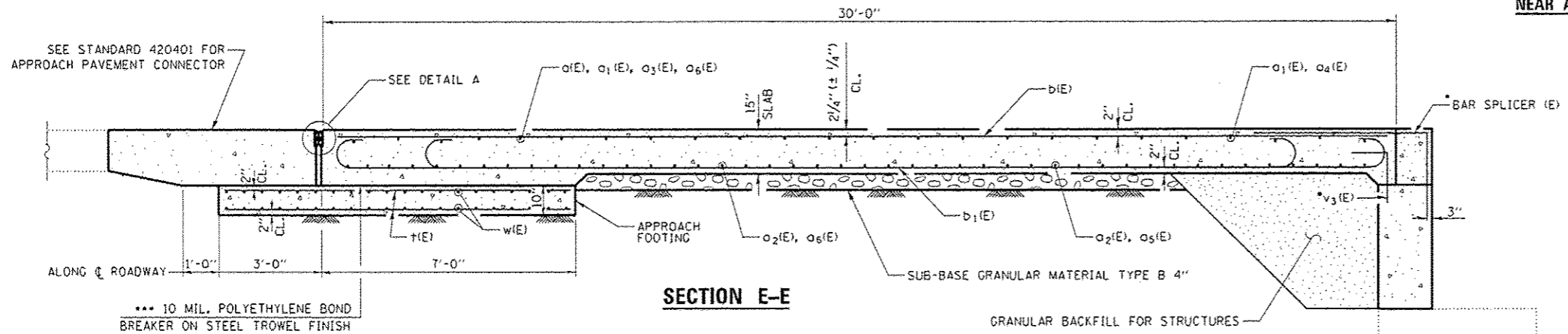

SECTION E-E

SEE STANDARD 420401 FOR APPROACH PAVEMENT CONNECTOR

SEE DETAIL A

*** 10 MIL. POLYETHYLENE BOND BREAKER ON STEEL TROWEL FINISH

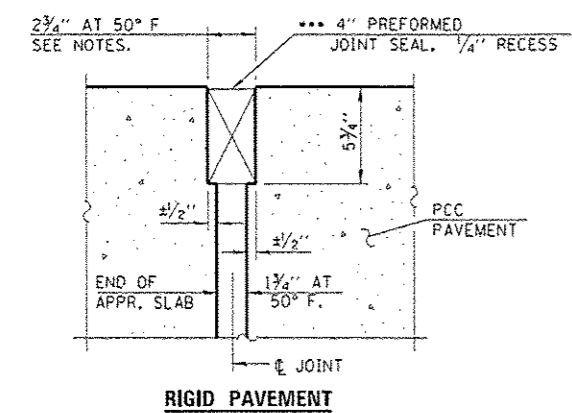

RIGID PAVEMENT

DETAIL A

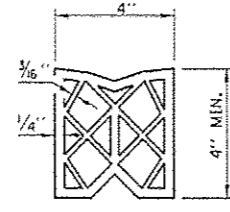

PREFORMED JOINT SEAL

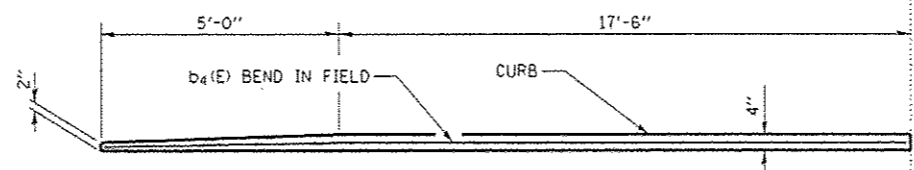

VIEW F-F

**BILL OF MATERIAL
AT WEST END APPROACHS**

BAR	NO.	SIZE	LENGTH	SHAPE
a(E)	14	#4	11'-3"	—
a1(E)	34	#4	10'-9"	—
a2(E)	90	#5	11'-2"	—
a3(E)	14	#4	19'-7"	—
a4(E)	10	#4	19'-3"	—
a5(E)	19	#5	19'-3"	—
a6(E)	26	#5	19'-3"	—
b(E)	30	#4	29'-9"	—
b1(E)	90	#9	29'-9"	—
b2(E)	2	#4	17'-3"	—
t(E)	80	#4	9'-9"	—
w(E)	80	#5	11'-2"	—
w1(E)	40	#6	19'-3"	—
CONCRETE STRUCTURE			CU YD	12.1
CONCRETE SUPERSTRUCTURE			CU YD	54.0
REINFORCEMENT BARS, EPOXY COATED			POUNDS	14000

BARS INDICATED THUS 1 x 2-#5 ETC. INDICATES 1 LINE OF BARS WITH 2 LENGTHS PER LINE.

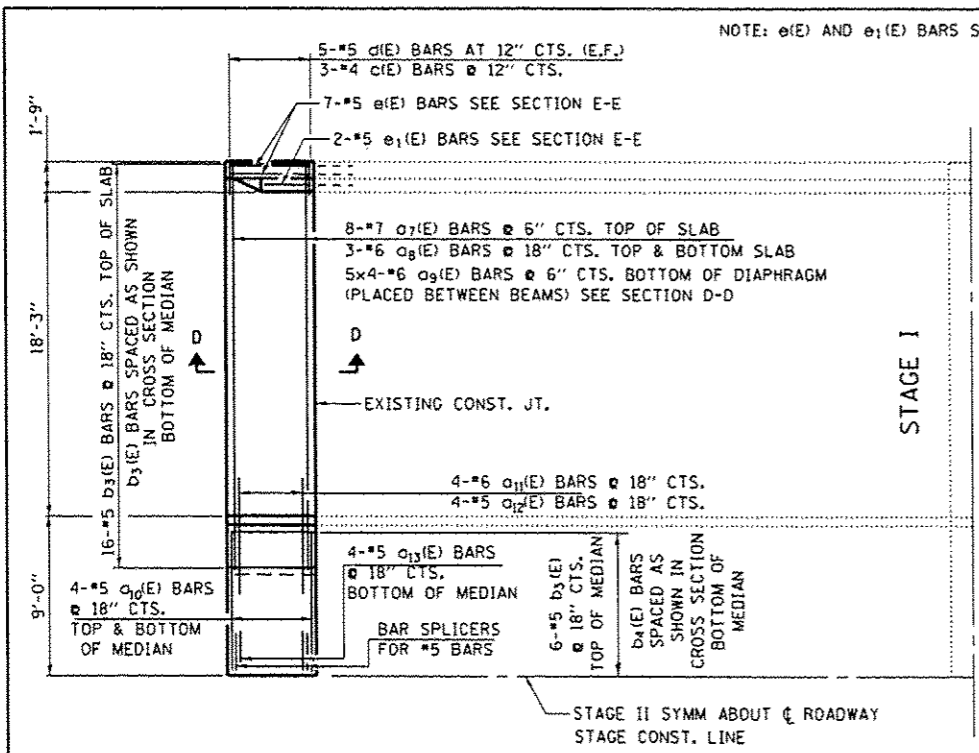

HALF PLAN

WEST END DECK FOR STAGE I SHOWN,
EAST END SIMILAR THRU 180 DEG. ROTATION ABOUT CENTERLINE OF STRUCTURE

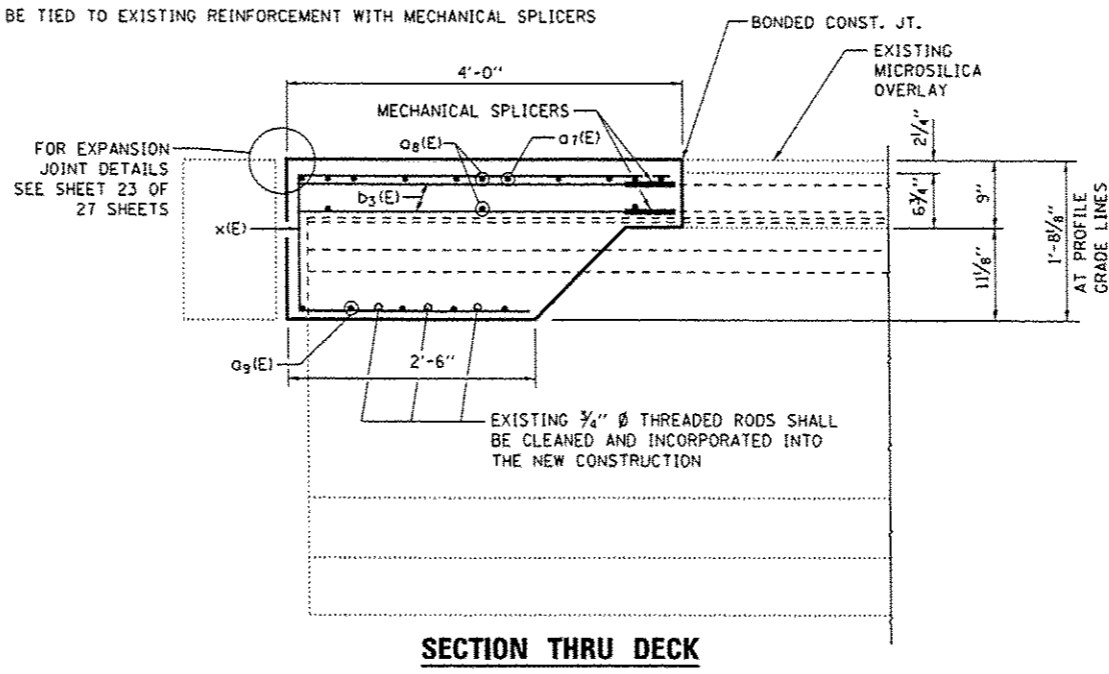

SECTION THRU DECK

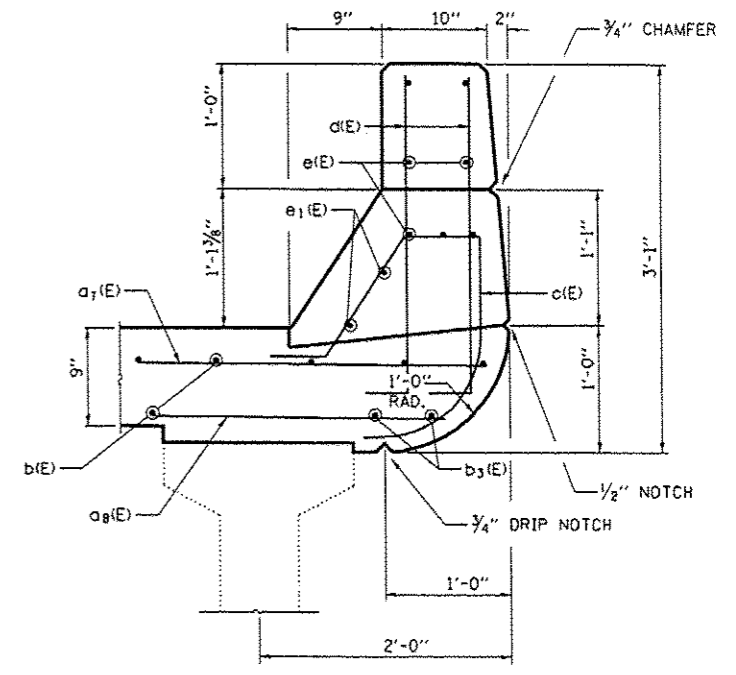

SECTION THRU PARAPET

BILL OF MATERIAL

AT WEST ABUTMENT SUPERSTRUCTURE

BAR NO.	SIZE	LENGTH	SHAPE
a7(E)	#7	22'-11"	—
a8(E)	#6	22'-11"	—
a9(E)	#6	6'-0"	—
a10(E)	#5	8'-3"	—
a11(E)	#6	5'-7"	—
a12(E)	#5	3'-10"	—
a13(E)	#6	2'-7"	—
b3(E)	#5	3'-4"	—
b4(E)	#4	3'-4"	—
c(E)	#4	5'-0"	—
d(E)	#5	2'-11"	—
e(E)	#5	3'-9"	—
e1(E)	#5	1'-9"	—
x(E)	#6	7'-2"	—
x1(E)	#6	7'-11"	—
CONCRETE REMOVAL			CU YD 12.4
CONCRETE SUPERSTRUCTURE			CU YD 12.8
REINFORCEMENT BARS, EPOXY COATED			POUNDS 3760

BARS INDICATED THUS 1 X 2-#5 ETC. INDICATES 1 LINE OF BARS WITH 2 LENGTHS PER LINE.

NOTE 1:
IN ACCORDANCE WITH ART. 508 OF THE STANDARD SPECS.
COST TO BE PAID AT THE CONTRACT UNIT PRICE EACH FOR
BAR SPLICER, SPECIAL.

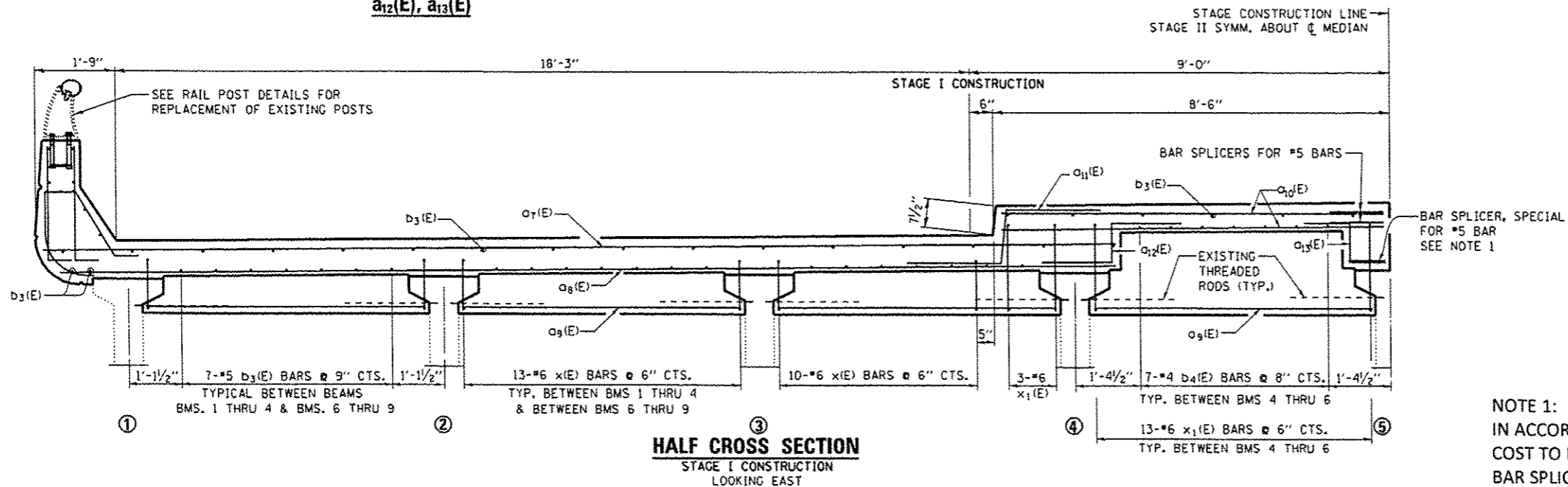
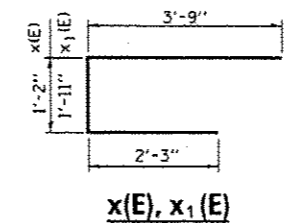
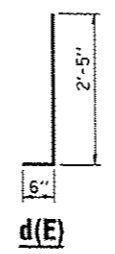
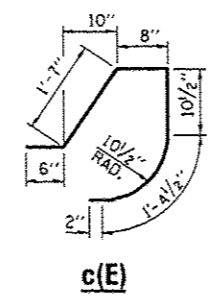
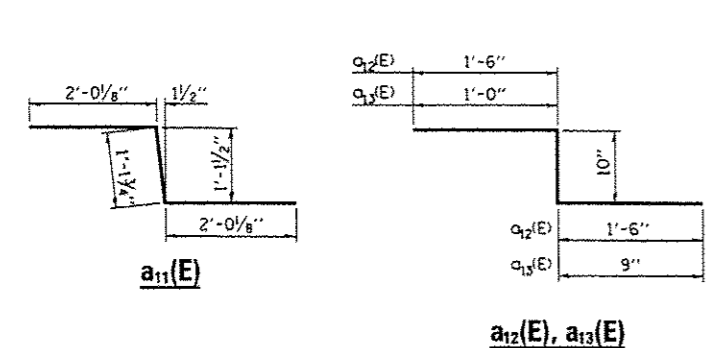

HALF CROSS SECTION
STAGE I CONSTRUCTION
LOOKING EAST

FILE NAME =	USER NAME = woodshankr1	DESIGNED - RON WOODSHANK	REVISED - 6/21/2014
0:\pwork\p\midst\woodshankr1\201308312\366074-shr-detals.dgn		DRAWN - RON WOODSHANK	REVISED -
	PLOT SCALE = 1/8" = 1'-0"	CHECKED - YOGESH PATEL	REVISED -
	PLOT DATE = 6/25/2014	DATE - 2/10/2014	REVISED -

STATE OF ILLINOIS
DEPARTMENT OF TRANSPORTATION

SUPERSTRUCTURE RECONSTRUCTION
FOR STRUCTURE NO. 027-0010

F.A.P. RTE. 697	SECTION (27-1HB-2)IR	COUNTY FORD	TOTAL SHEETS 27	SHEET NO. 20
SCALE: _____				CONTRACT NO. 66074
SHEET NO. 6 OF 13 SHEETS				ILLINOIS FED. AID PROJECT

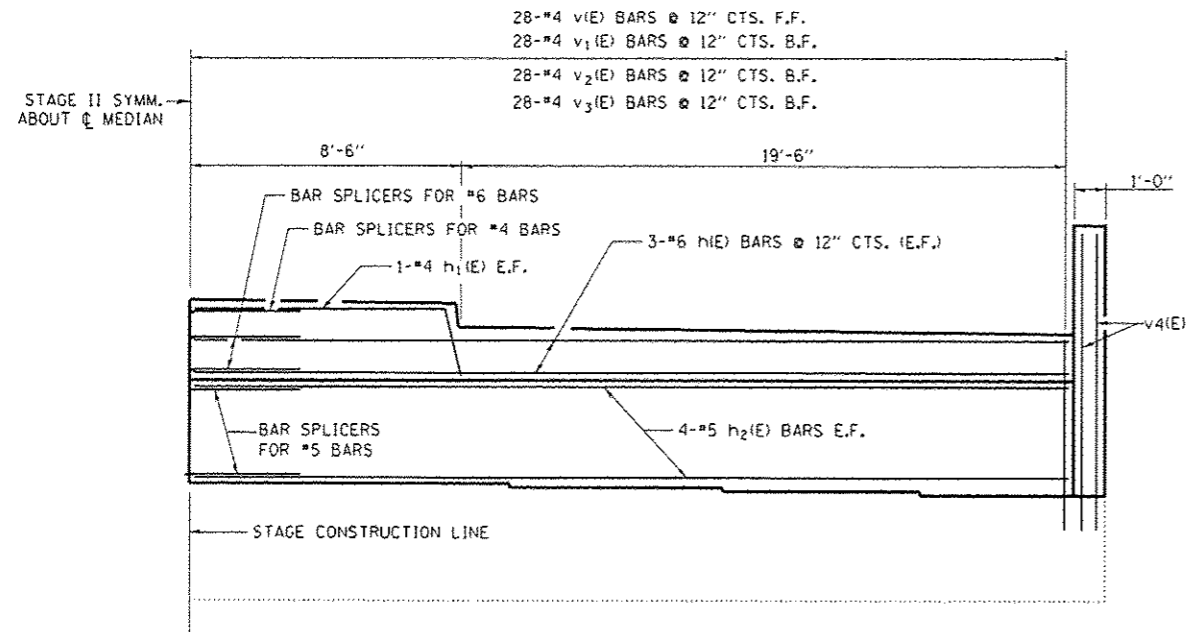

ELEVATION AT ABUTMENT
STAGE I

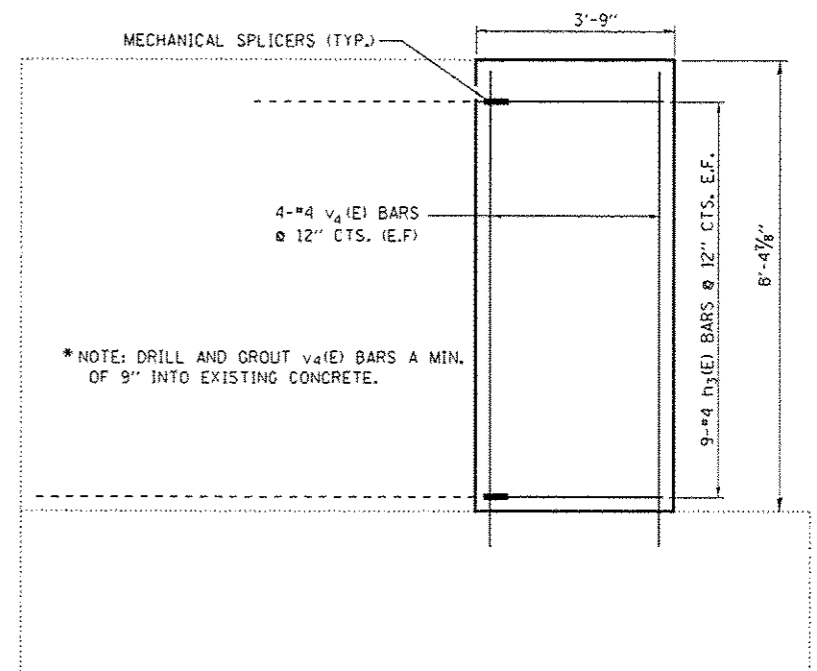
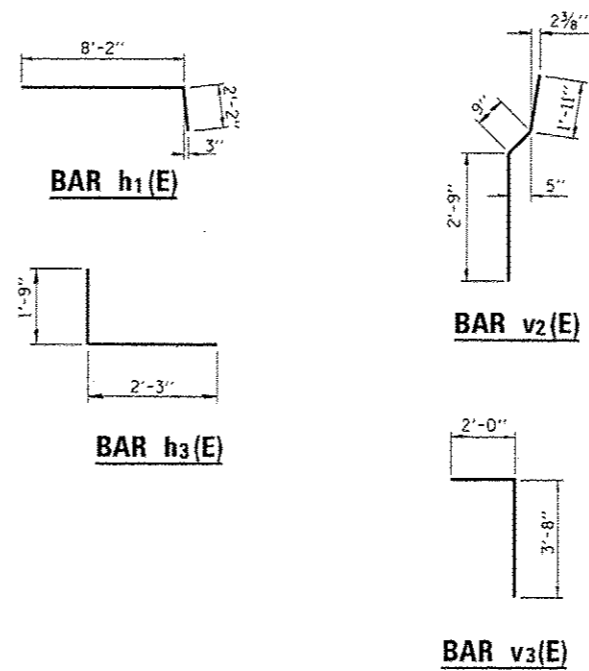

WING WALL ELEVATION

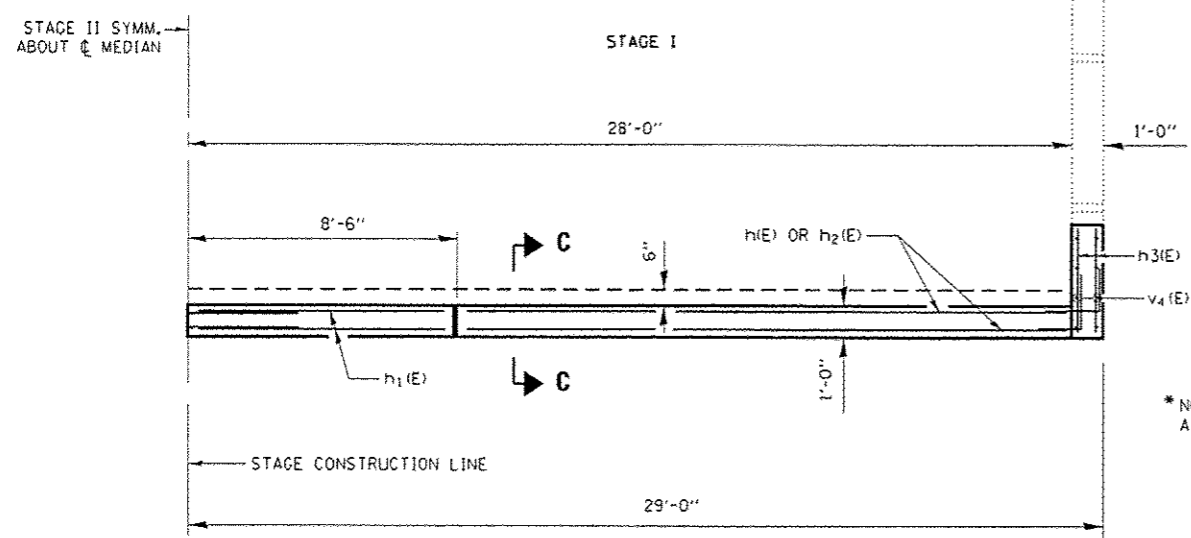

PLAN AT ABUTMENT
STAGE I
WEST ABUT. SHOWN, EAST ABUT.
SIMILAR THRU 180 DEG. ROTATION
ABOUT CENTERLINE OF STRUCTURE

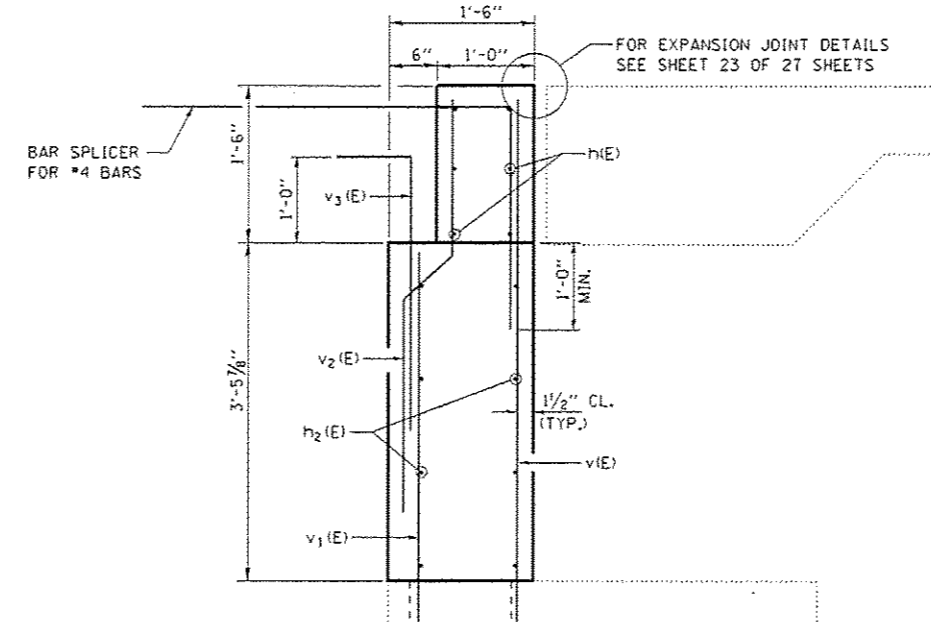

SECTION C-C

* DRILLING AND EPOXY GROUTING OF TIE BARS INTO EXISTING HARDENED CONCRETE TO BE DONE ACCORDING TO ARTICLE 584 OF THE STANDARD SPECIFICATIONS.

BILL OF MATERIAL
FOR WEST ABUTMENT

BAR	NO.	SIZE	LENGTH	SHAPE
h(E)	12	6	27'-9"	—
h1(E)	4	4	10'-4"	—
h2(E)	16	5	27'-9"	—
h3(E)	36	4	4'-0"	—
v(E)	56	4	5'-7"	—
v1(E)	56	4	4'-1"	—
v2(E)	56	4	5'-5"	—
v3(E)	56	4	5'-8"	—
v4(E)	16	4	8'-9"	—
CONCRETE REMDVAL			CU YD	16.5
CONCRETE STRUCTURE			CU YD	16.5
REINFORCEMENT BARS, EPOXY COATED			POUNDS	1960

BARS INDICATED THUS 1 X 2-#5 ETC. INDICATES 1 LINE OF BARS WITH 2 LENGTHS PER LINE.

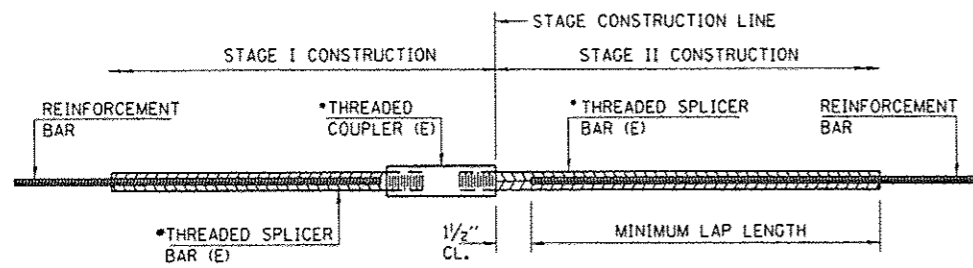

STANDARD BAR SPLICER ASSEMBLY

MINIMUM LAP LENGTHS						
BAR SIZE TO BE SPLICED	TABLE 1	TABLE 2	TABLE 3	TABLE 4	TABLE 5	TABLE 6
3, 4	1'-5"	1'-11"	2'-1"	2'-4"	2'-7"	2'-11"
5	1'-9"	2'-5"	2'-7"	2'-11"	3'-3"	3'-8"
6	2'-1"	2'-11"	3'-1"	3'-6"	3'-10"	4'-5"
7	2'-9"	3'-10"	4'-2"	4'-8"	5'-2"	5'-10"
8	3'-8"	5'-1"	5'-5"	6'-2"	6'-9"	7'-8"
9	4'-7"	6'-5"	6'-10"	7'-9"	8'-7"	9'-8"

- TABLE 1: BLACK BAR, 0.8 CLASS C
- TABLE 2: BLACK BAR, TOP BAR LAP, 0.8 CLASS C
- TABLE 3: EPOXY BAR, 0.8 CLASS C
- TABLE 4: EPOXY BAR, TOP BAR LAP, 0.8 CLASS C
- TABLE 5: EPOXY BAR, CLASS C
- TABLE 6: EPOXY BAR, TOP BAR TOP, CLASS C

THREADED SPLICER BAR LENGTH = MIN. LAP LENGTH + 1/2" + THREAD LENGTH

- EPOXY NOT REQUIRED ON BAR SPLICER ASSEMBLY COMPONENTS USED IN CONJUNCTION WITH BLACK BARS.

LOCATION	BAR SIZE	NO. ASSEMBLIES REQUIRED	TABLE FOR MINIMUM LAP LENGTH
WEST END, TOP AND BOTTOM OF MEDIAN AT STAGE CONST. LINE	#5	8	3
EAST END, TOP AND BOTTOM OF MEDIAN AT STAGE CONST. LINE	#5	8	3
TOTAL		16	

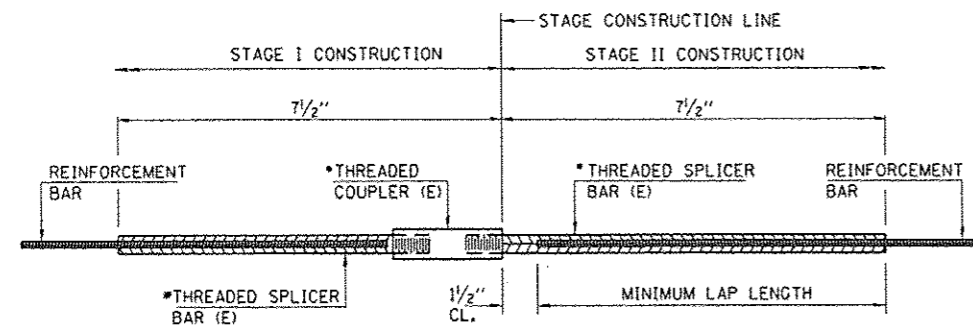

BAR SPLICER, SPECIAL ASSEMBLY FOR #5 BAR AT CENTERLINE OF MEDIAN FOR STAGE CONSTRUCTION

LOCATION	BAR SIZE	NO. ASSEMBLIES REQUIRED
WEST END, BOTTOM OF MEDIAN CAP OVER BEAM AT STAGE CONST. LINE	#5	4
EAST END, BOTTOM OF MEDIAN CAP OVER BEAM AT STAGE CONST. LINE	#5	4
TOTAL		8

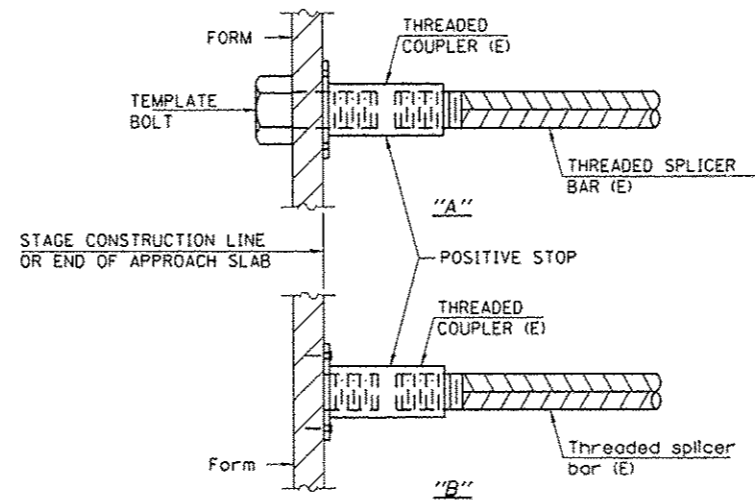

INSTALLATION AND SETTING METHODS

- "A": SET BAR SPLICER ASSEMBLY BY MEANS OF A TEMPLATE BOLT.
- "B": SET BAR SPLICER ASSEMBLY BY NAILING TO WOOD FORMS OR CEMENTING TO STEEL FORMS.
- (E) : INDICATES EPOXY COATING.

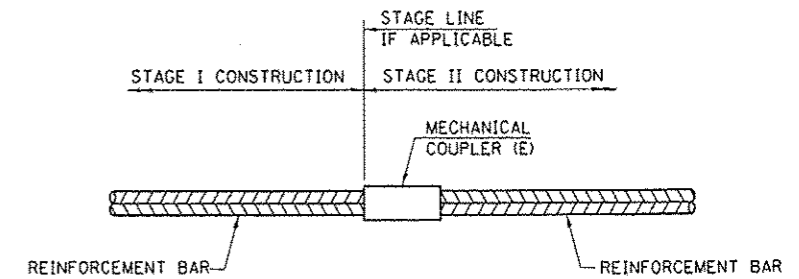

STANDARD MECHANICAL SPLICER

LOCATION	BAR SIZE	NO. ASSEMBLIES REQUIRED
W. END DECK (STAGE I)	#5	37
W. END MEDIAN (STAGE I)	#5	6
W. END MEDIAN (STAGE I)	#4	7
W. END PARAPET (STAGE I)	#5	9
E. END DECK (STAGE I)	#5	37
E. END MEDIAN (STAGE I)	#5	6
E. END MEDIAN (STAGE I)	#4	7
E. END PARAPET (STAGE I)	#5	9
W. END DECK (STAGE II)	#5	37
W. END MEDIAN (STAGE II)	#5	6
W. END MEDIAN (STAGE II)	#4	7
W. END PARAPET (STAGE II)	#5	9
E. END DECK (STAGE II)	#5	37
E. END MEDIAN (STAGE II)	#5	6
E. END MEDIAN (STAGE II)	#4	7
E. END PARAPET (STAGE II)	#5	9
TOTAL		236

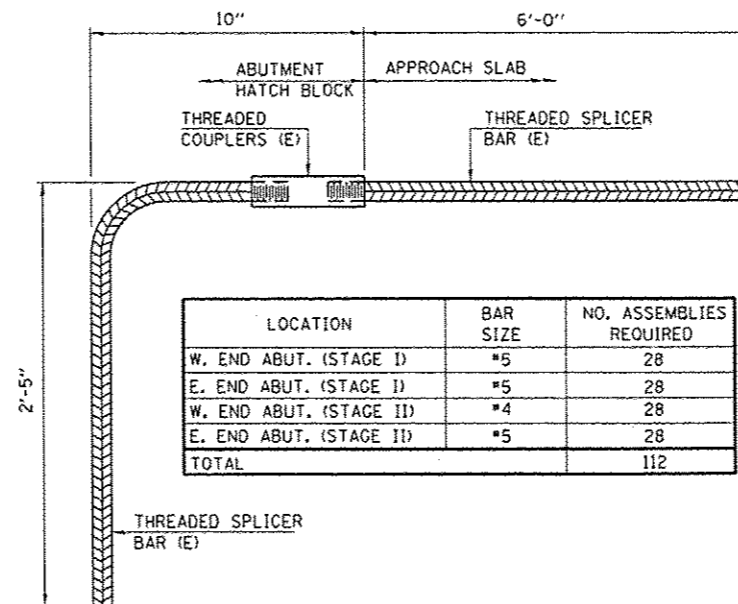

LOCATION	BAR SIZE	NO. ASSEMBLIES REQUIRED
W. END ABUT. (STAGE I)	#5	28
E. END ABUT. (STAGE I)	#5	28
W. END ABUT. (STAGE II)	#4	28
E. END ABUT. (STAGE II)	#5	28
TOTAL		112

BAR SPLICER ASSEMBLY FOR #5 BAR ON STUB ABUTMENTS

NOTES

- SPLICER BARS SHALL BE DEFORMED WITH THREADED ENDS AND HAVE A MINIMUM 60 KSI YIELD STRENGTH.
- ALL REINFORCEMENT SHALL BE LAPPED AND TIED TO THE SPLICER BARS.
- BAR SPLICER ASSEMBLIES SHALL BE EPOXY COATED ACCORDING TO THE REQUIREMENTS FOR REINFORCEMENT BARS. SEE SECTION 508 OF THE STANDARD SPECIFICATIONS.
- SEE APPROVED LIST OF BAR SPLICER ASSEMBLIES AND MECHANICAL SPLICERS FOR ALTERNATIVES.

BSD-1 1-27-12

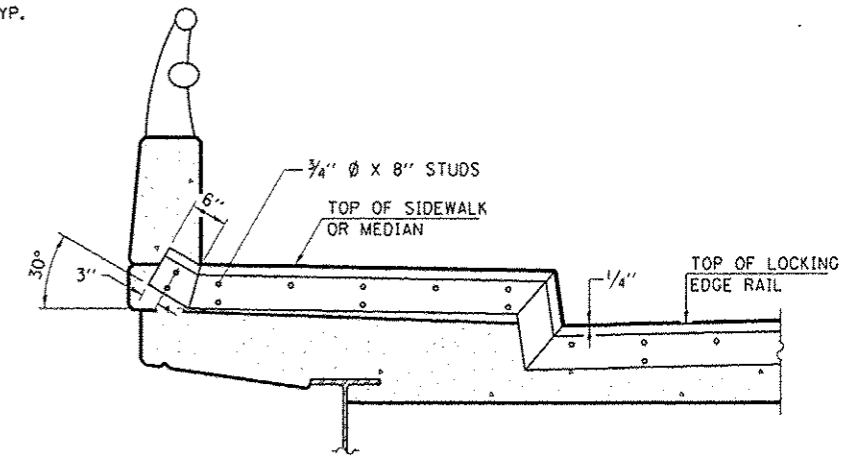
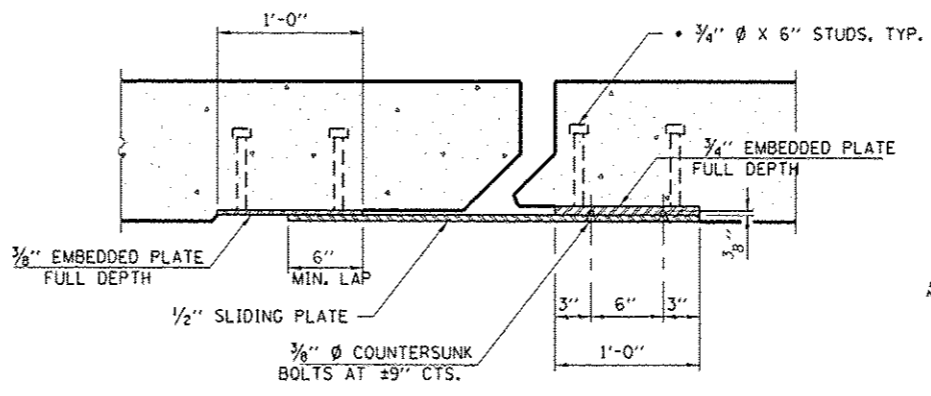
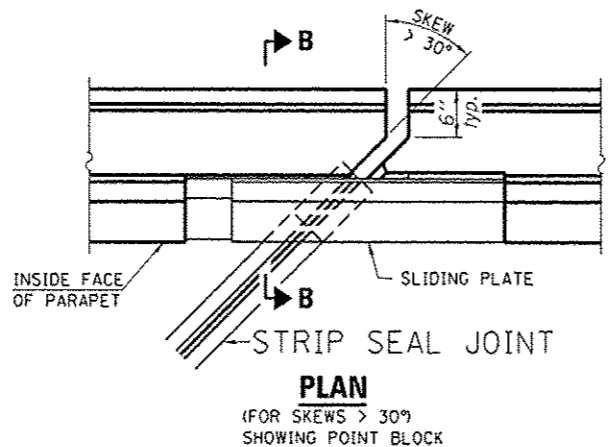
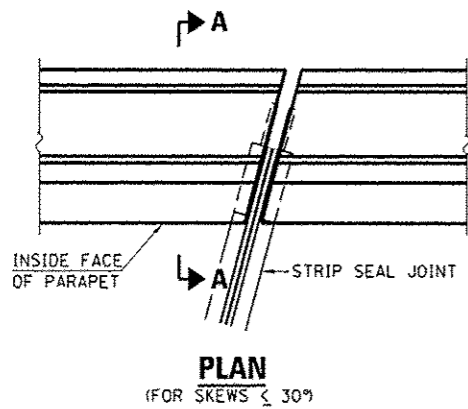

TYPICAL END TREATMENT AT SIDEWALK OR MEDIAN
SHORTER PLATES WITH A SINGLE ROW OF STUDS AT 12" CTS. MAY BE NECESSARY ON MEDIANS WHICH ARE SHALLOWER THAN 9". SEE MANUFACTURER'S RECOMMENDATION.

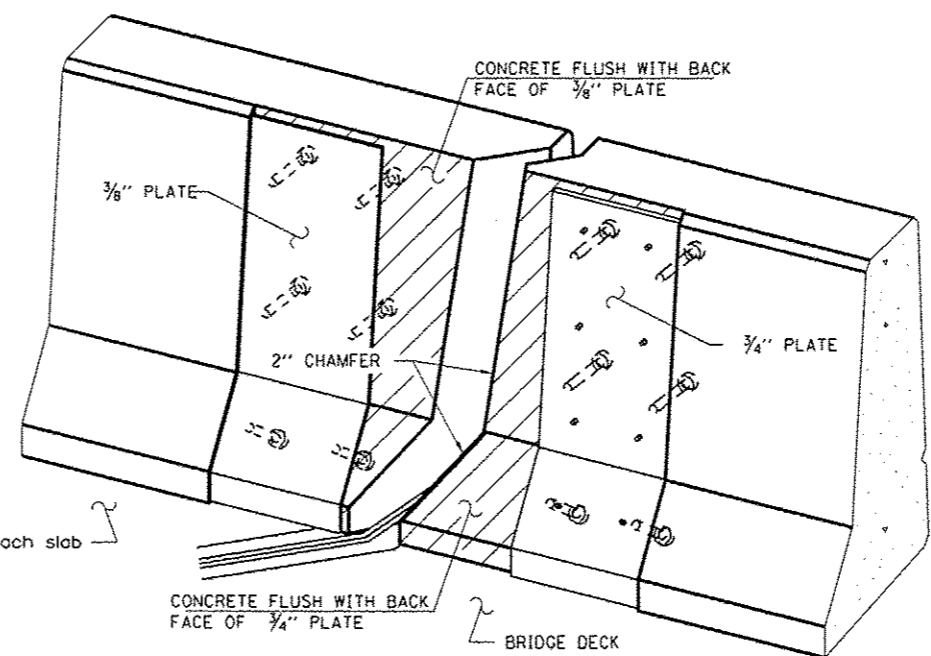
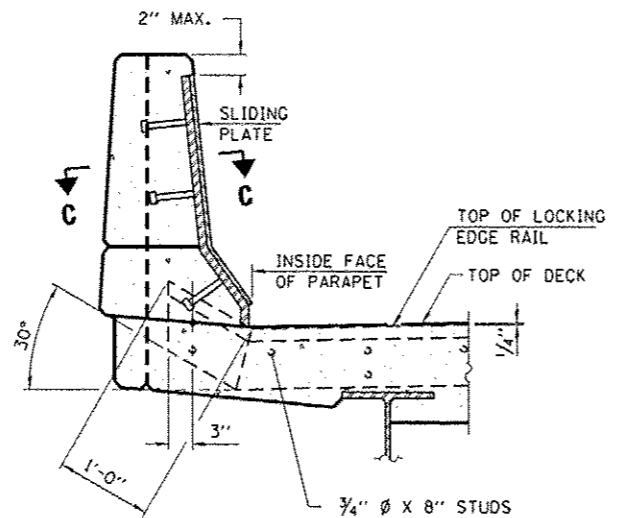
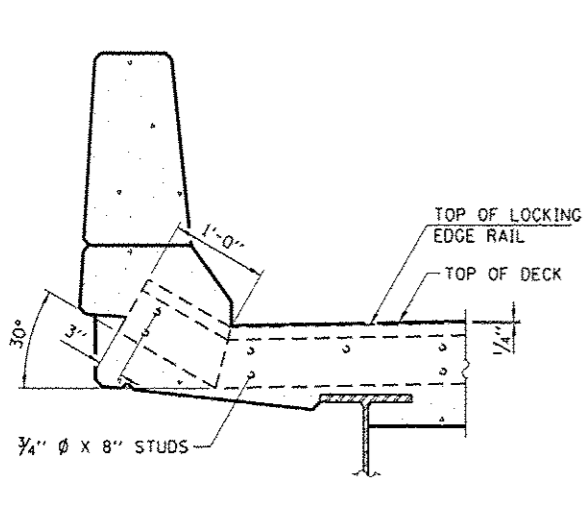

NOTES:
THE STRIP SEAL SHALL BE MADE CONTINUOUS AND SHALL HAVE A MINIMUM THICKNESS OF 1/4". THE CONFIGURATION OF THE STRIP SEAL SHALL MATCH THE CONFIGURATION OF THE LOCKING EDGE RAILS. OPEN OR "WEBBED" STRIP SEAL GLAND CONFIGURATIONS ARE NOT PERMITTED. THE GLAND SHALL BE SIZED FOR A MAXIMUM RATED MOVEMENT OF 4 INCHES.
THE LOCKING EDGE RAILS DEPICTED ARE CONCEPTUAL ONLY. EXCEPT FOR THE MINIMUM DIMENSIONS SHOWN. THE ACTUAL CONFIGURATION OF THE LOCKING EDGE RAILS AND MATCHING STRIP SEAL MAY VARY FROM MANUFACTURER TO MANUFACTURER. FLANGED EDGE RAILS WILL NOT BE ALLOWED. LOCKING EDGE RAILS MAY BE SPLICED AT SLOPE DISCONTINUITIES.
THE MANUFACTURER'S RECOMMENDED INSTALLATION METHODS SHALL BE FOLLOWED.
THE JOINT OPENING AND DECK DIMENSIONS DETAILED ON THE SUPERSTRUCTURE ARE BASED ON A ROLLED RAIL EXPANSION JOINT. IF THE CONTRACTOR ELECTS TO USE THE WELDED RAIL EXPANSION JOINT, THE OPENING AND DECK DIMENSIONS SHALL BE MODIFIED ACCORDING TO THE DIMENSIONS DETAILED ON THIS SHEET. REQUIRED MODIFICATIONS SHALL BE MADE AT NO ADDITIONAL COST TO THE STATE.
ALL STEEL COMPONENTS SHALL BE GALVANIZED AFTER FABRICATION ACCORDING TO ARTICLE 520.03 OF THE STANDARD SPECIFICATIONS. MAXIMUM SPACE BETWEEN RAIL SEGMENTS SHALL BE 3/16", SEALED WITH A SUITABLE SEALANT. JOINTS IN RAILS WITHIN 10 FT. OF CURBS SHALL BE WELDED.
PARAPET PLATES AND ANCHORAGE STUDS FOR SKEWS $> 30^\circ$ INCLUDED IN THE COST OF PREFORMED JOINT STRIP SEAL.

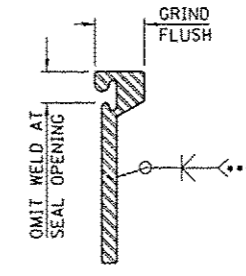
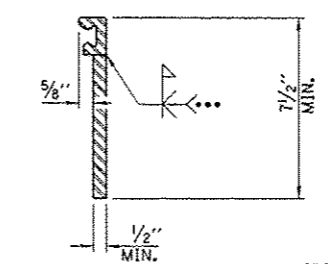
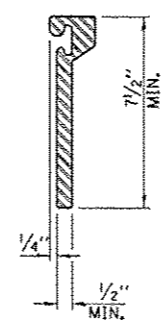
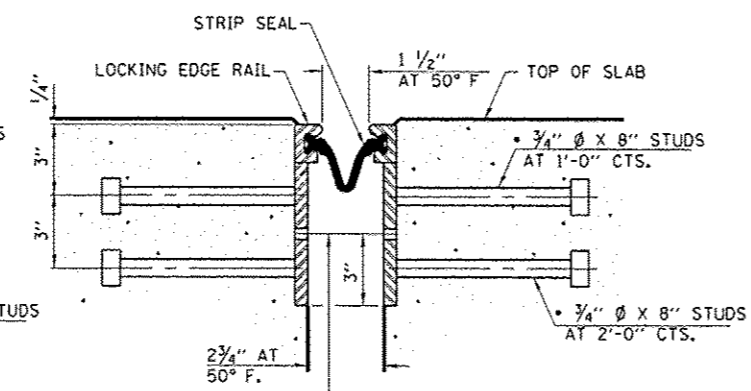
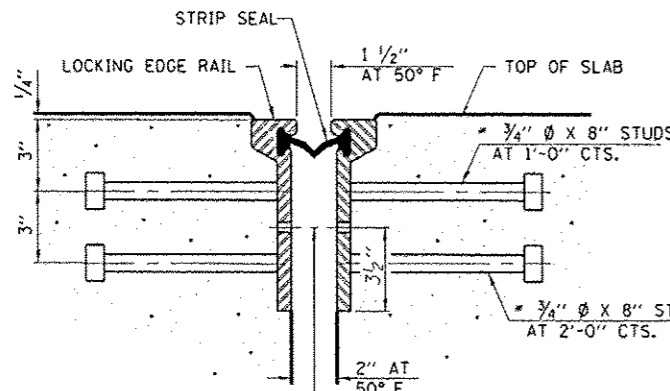

... BACK GOUGE NOT REQUIRED IF COMPLETE JOINT PENETRATION IS VERIFIED BY MOCK-UP.

1/16" ϕ HOLES AT 4'-0" CTS. FOR 3/8" ϕ BOLTS. ALL BOLTS SHALL BE BURNED, SAWED, OR CHIPPED OFF FLUSH WITH THE PLATES AFTER FORMS ARE REMOVED, TYP.

1/16" ϕ HOLES AT 4'-0" CTS. FOR 3/8" ϕ BOLTS. ALL BOLTS SHALL BE BURNED, SAWED, OR CHIPPED OFF FLUSH WITH THE PLATES AFTER FORMS ARE REMOVED, TYP.

• GRANULAR OR SOLID FLUX FILLED HEADED STUDS CONFORMING TO ARTICLE 1006.32 OF THE STD. SPECS., AUTOMATICALLY END WELDED.

BILL OF MATERIAL

ITEM	UNIT	TOTAL
PREFORMED JOINT STRIP SEAL	FOOT	114

LOCKING EDGE RAILS

THE INSIDE OF THE LOCKING EDGE RAIL GROOVE SHALL BE FREE OF WELD RESIDUE.
ROLLED RAIL SHOWN, WELDED RAIL SIMILAR.

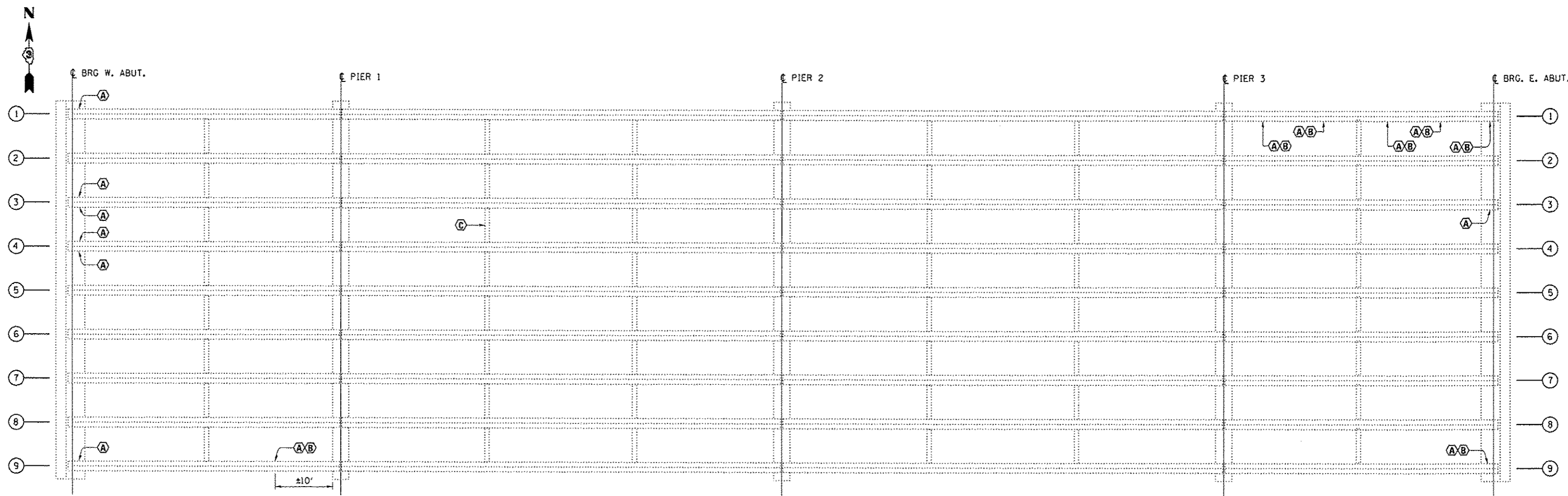

EXISTING FRAMING PLAN

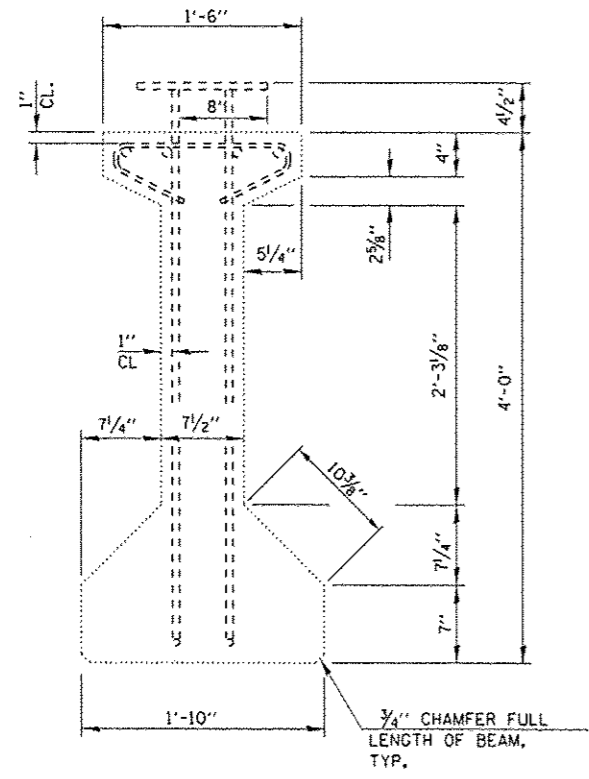

TYPICAL ELEVATION AT END OF BEAM

	LOCATION	WIDTH	HEIGHT	SO FT
A	WEB	3'	2'-3 ¹ / ₈ "	7
B	FLANGE	3'	17 ³ / ₈ "	4
C	DIAPHRAGM	6'	6"	3

BILL OF MATERIAL

ITEM	UNIT	TOTAL
POLYMER MODIFIED PORTLAND CEMENT MORTAR	SO FT	98
STRUCTURAL REPAIR OF CONCRETE (DEPTH EQUAL TO OR LESS THAN 5")	SO FT	31

NOTES.

- POLYMER MODIFIED PORTLAND CEMENT MORTAR SHALL BE USED ON THE WEB OF THE BEAM.
- STRUCTURAL REPAIR OF CONCRETE (DEPTH EQUAL TO OR LESS THAN 5") SHALL BE USED ONLY ON THE FLANGE AREA OF THE BEAM.

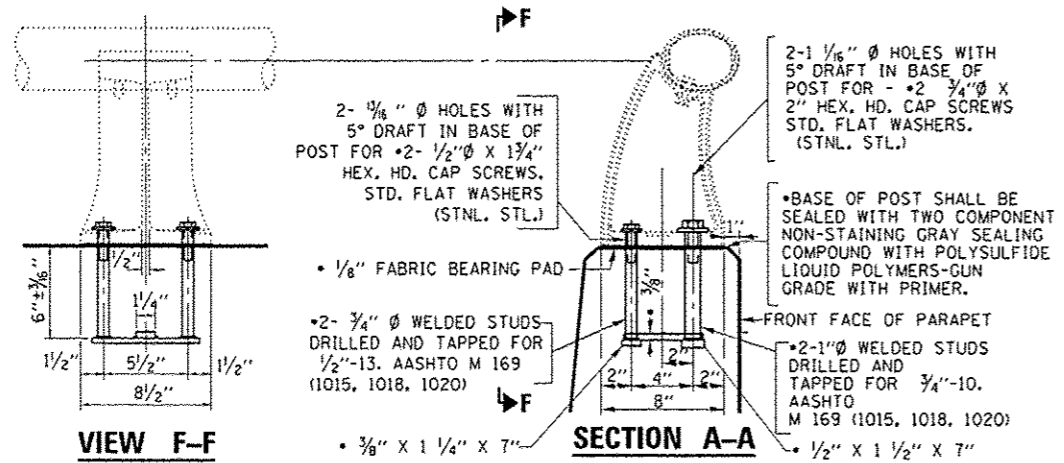

• NEW RAIL POST ANCHORAGE DEVICES WILL BE REQUIRED AT EACH LOCATION WHERE POSTS ARE CONNECTED TO NEW CONSTRUCTION. COST SHALL BE INCLUDED WITH REMOVING AND RE-ERECTING EXISTING RAILING.

RAIL POST DETAILS

NOTES:
 ALL POSTS SHALL BE NORMAL TO PARAPET.
 ALL JOINTS IN RAIL SHALL BE SPLICED PER DETAIL.
 PROVIDE 1- 1/8" AND 2- 1/16" ALUMINUM SHIMS FOR 25% OF THE POSTS.
 RAIL ELEMENTS SHALL BE PARALLEL TO GRADE-HIGH SPOTS WILL BE GROUND AND LOW SPOTS SHIMMED.
 THIS WORK SHALL BE PAID FOR AT THE CONTRACT UNIT PRICE PER FOOT FOR REMOVING AND RE-ERECTING EXISTING RAILING.
 HORIZONTAL RAIL ELEMENT & RAIL POSTS SHOWN ARE FOR INFORMATION ONLY.

FILE NAME : c:\pwork\pwork\woodshankr1\08380312\366074.sht-details.dgn	USER NAME = woodshankr1	DESIGNED - RON WOODSHANK	REVISED -	STATE OF ILLINOIS DEPARTMENT OF TRANSPORTATION	BRIDGE RAIL DETAILS FOR STRUCTURE NO. 027-0010	F.A.P. RTE.	SECTION	COUNTY	TOTAL SHEETS	SHEET NO.
	PLOT SCALE = 100.00' / in.	CHECKED - YOGESH PATEL	REVISED -			697	(27-1HB-2)JR	FORD	27	25
PLOT DATE = 5/19/2014	DATE - 2/10/2014	REVISED -		SCALE: _____	SHEET NO. 11 OF 13 SHEETS	STA. _____ TO STA. _____	CONTRACT NO. 66074			
ILLINOIS FED. AID PROJECT										



Illinois Department of Transportation
Division of Highways
IDOT

SOIL BORING LOG

Page 1 of 2

Date 6/11/62

ROUTE I-57 (FAI 57) DESCRIPTION IL 9 over I-57 at Paxton LOGGED BY C.I.B.

SECTION 27-1HB-2 LOCATION NW 1/4, SEC. 18, TWP. 23N, RNG. 10E, 3rd PM.

COUNTY Ford DRILLING METHOD Hollow Stem Auger HAMMER TYPE

STRUCT. NO. 027-0010
Station 329+98.30
BORING NO. 05 (W. Abut.)
Station 23+79
Offset 15.0 ft Rt.
Ground Surface Elev. 800.53 ft

DEPTH (ft)	DIAMETER (in)	UNIFORMITY COEFFICIENT (U)	MOISTURE (%)	SOIL DESCRIPTION	DEPTH (ft)	DIAMETER (in)	UNIFORMITY COEFFICIENT (U)	MOISTURE (%)
				Very Stiff Gray Clay (Till)			3.9B	17
797.03	8	0.8 S	21				16	3.1 B
				Very Stiff Yellowish Brown & Gray Clay (Till)			16	3.3 B
	12	2.3 S	23				14	3.1 B
792.03	10	2.7 B	22				14	3.1 B
				Hard Brownish Gray and Gray Clay (Till)			14	3.1 B
	24	9.1 S	15				12	2.3 B
							12	2.3 B
787.03				Stiff Gray Clay (Till)			11	1.9 B
	20	5.8 B	17				13	2.7 B
784.53				Very Stiff Gray Clay (Till) (Occasional Thin Silt Layers)			13	2.7 B
	16	3.9 B	19				12	2.1 B
782.03				Stiff Brownish Gray Sandy Clay Loam (Till)			12	2.1 B
780.53	14	1.0S	14					

The Unconfined Compressive Strength (UCS) Failure Mode is indicated by (B-Bulge, S-Shear, P-Penetrometer)
The SPT (N value) is the sum of the last two blow values in each sampling zone (AASHTO T206)

BBS, form 137 (Rev. 8-99)



Illinois Department of Transportation
Division of Highways
IDOT

SOIL BORING LOG

Page 2 of 2

Date 6/11/62

ROUTE I-57 (FAI 57) DESCRIPTION IL 9 over I-57 at Paxton LOGGED BY C.I.B.

SECTION 27-1HB-2 LOCATION NW 1/4, SEC. 18, TWP. 23N, RNG. 10E, 3rd PM.

COUNTY Ford DRILLING METHOD Hollow Stem Auger HAMMER TYPE

STRUCT. NO. 027-0010
Station 329+98.30
BORING NO. 05 (W. Abut.)
Station 23+79
Offset 15.0 ft Rt.
Ground Surface Elev. 800.53 ft

DEPTH (ft)	DIAMETER (in)	UNIFORMITY COEFFICIENT (U)	MOISTURE (%)	SOIL DESCRIPTION	DEPTH (ft)	DIAMETER (in)	UNIFORMITY COEFFICIENT (U)	MOISTURE (%)
				Very Stiff Gray Clay (Till) (Occasional Thin Silt Layers) (continued)			B	
759.53							14	2.9 B
				Very Stiff Gray Clay (Till)			14	3.5 B
	14	2.9 B	19				14	3.3 B
752.03				Stiff Gray Clay (Till)			13	1.9 B
	14	3.3 B	18					
750.03				End of Boring				

The Unconfined Compressive Strength (UCS) Failure Mode is indicated by (B-Bulge, S-Shear, P-Penetrometer)
The SPT (N value) is the sum of the last two blow values in each sampling zone (AASHTO T206)

BBS, form 137 (Rev. 8-99)

FILE NAME: c:\pwwork\pwwork\woodshankr\140380312	USER NAME: woodshankr	DESIGNED: RON WOODSHANK	REVISED: -	STATE OF ILLINOIS DEPARTMENT OF TRANSPORTATION	BORING LOGS-- WEST ABUT. FOR STRUCTURE NO. 027-0010	F.A.P. RTE. 697	SECTION (27-1HB-2)R	COUNTY FORD	TOTAL SHEETS 27	SHEET NO. 26
PLOT SCALE: 1/8" = 1' in.	CHECKED: YOGESH PATEL	REVISOR: -	SCALE: _____			SHEET NO. 12 OF 13 SHEETS	ILLINOIS FED. AID PROJECT			
PLOT DATE: 5/19/2014	DATE: 2/10/2014	REVISOR: -								

