

SHOULDER EDGE GUTTER

PAVEMENT EDGE GUTTER

CONCRETE GUTTER, TYPE B, (SPECIAL)

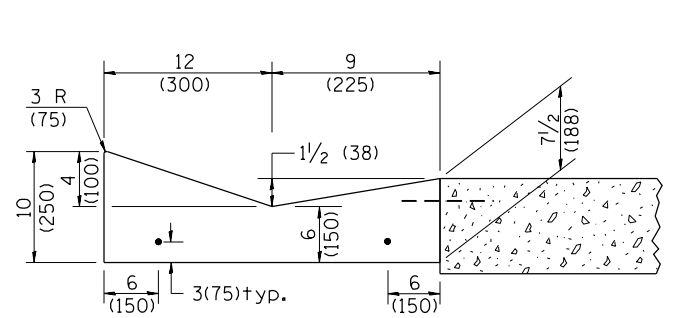

SECTION A-A

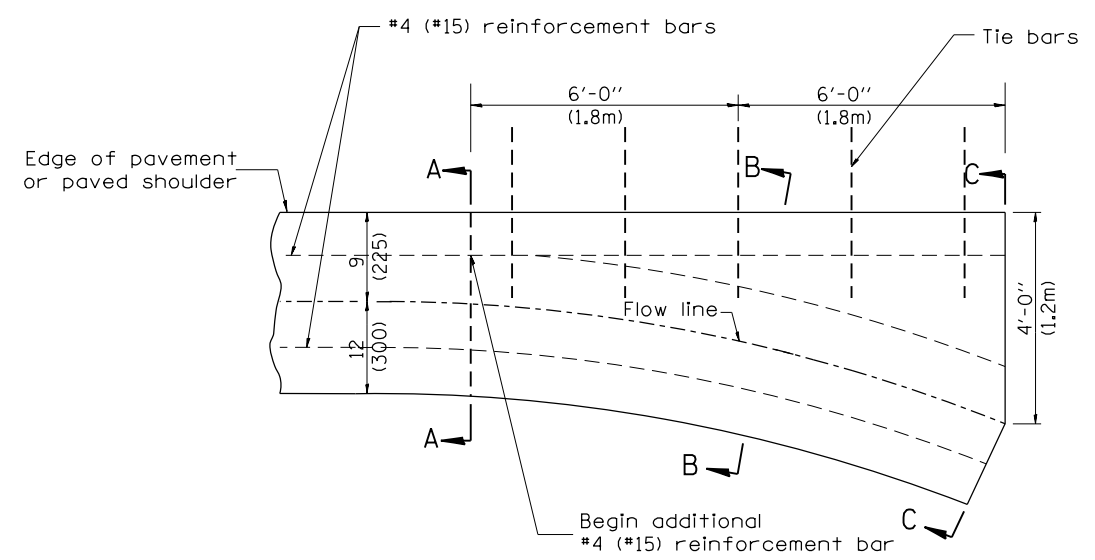

PLAN

**QUANTITY**  
Section C-C to A-A=  
0.73 cu. yd. concrete.

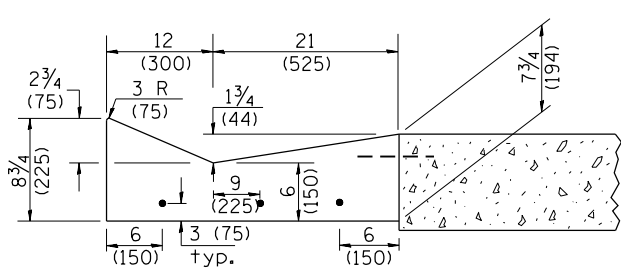

SECTION B-B

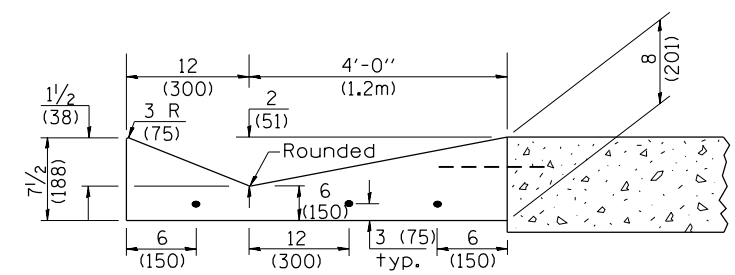

SECTION C-C

INLET

GENERAL NOTES:

1. CONCRETE GUTTER, TYPE B (SPECIAL) shall conform to the the applicable portions of Section 606.
2. Tie bars shall be No. 6 (No. 20) at 24" (600mm) centers unless otherwise shown.
3. Gutter, gutter inlets, gutter outlets, and gutter entrances shall be tied to rigid pavement in accordance with details shown on Standard 420001.
4. Joints shall be constructed in accordance with Article 606.06.
5. Welded wire fabric shall conform to Article 1006.10(c)(1), and shall not be less than 58 lbs/100 sq.ft. (2.83 kg/m<sup>2</sup>).

DESIGNER NOTES:  
1. INCLUDE STATE std. 420001.

QUANTITIES	
CALC. BY:	DATE:
CHECKED BY:	DATE:
QUANTITY CALCULATIONS ARE ON FILE AT THE DISTRICT 4 OFFICE; BUREAU OF PROJECT IMPLEMENTATION; DOCUMENTATION SECTION	

NO.	DATE	DESCRIPTION	BY
01-01-97		RENUM. A-1.01, NEW REVISION BOX, ELIMINATED	T.P.
		EXPANSION ANCHOR TIES	
03-06-98		CORRECT DIMENSIONING	J.A.
03-10-06		REVISED QUANTITY	M.A.
10-16-06		REVISED TO 2007 SPEC.	M.A.
11-16-07		REVISED QUANTITY	M.A.
02-15-11		CHANGED MODIFIED TO SPECIAL	R.D.

STATE OF ILLINOIS  
DEPARTMENT OF TRANSPORTATION

CONCRETE GUTTER, TYPE B, (SPECIAL)  
(INLET, OUTLET & ENTRANCE)

NOT TO SCALE

SHT. 1 OF 3  
CADD STD. 606201-D4

All dimensions are in inches (millimeters) unless otherwise noted.

F.A.S. RTE.	SECTION	COUNTY	TOTAL SHEETS	SHEET NO.
379	(101,111)RS-3	KNOX	33	29
FED. ROAD DIST. NO.				ILLINOIS FED. AID PROJECT

CONTRACT NO. 68B98