

PUBLIC ROAD

COMMERCIAL (P.C.C.)

COMMERCIAL (HOT-MIX ASPHALT)

PRIVATE ENTRANCE (P.C.C.)

PRIVATE ENTRANCE (HOT-MIX ASPHALT)

FIELD ENTRANCE (AGGREGATE)

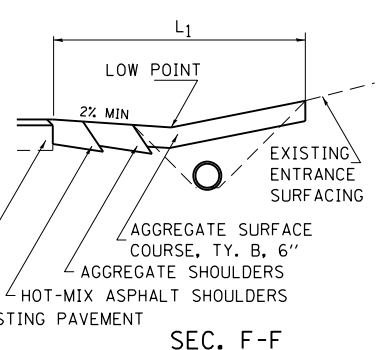
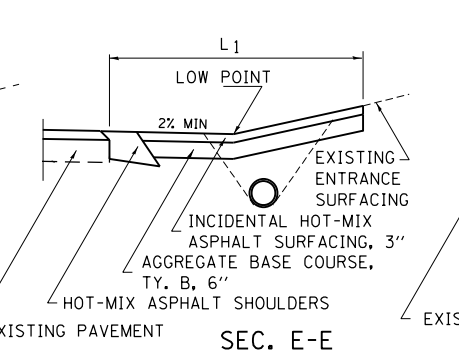
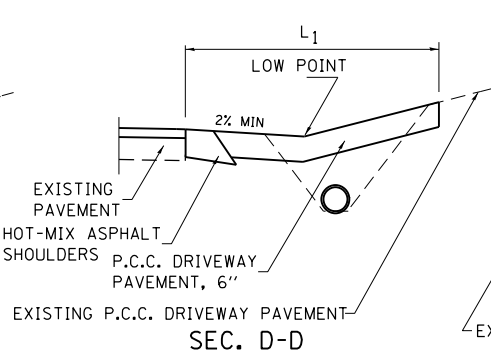
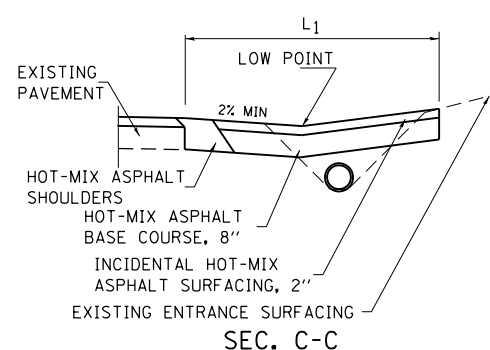
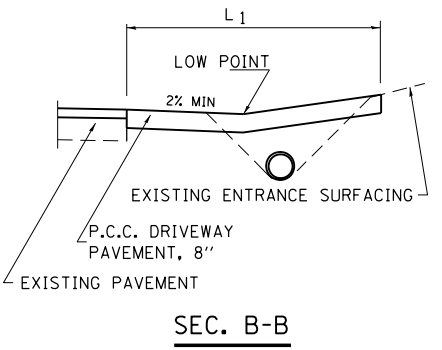
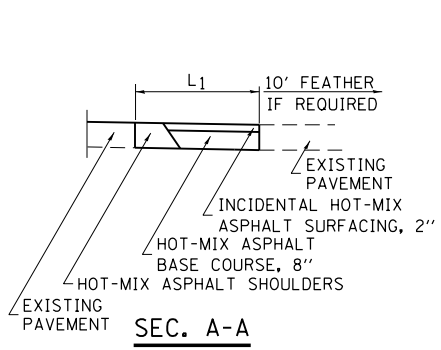
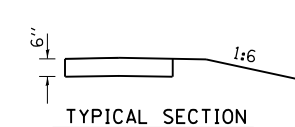
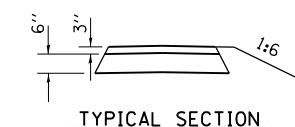
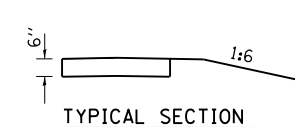
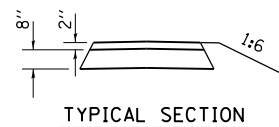
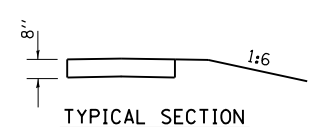
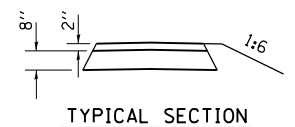

ENTRANCE SCHEDULE

TYPE	SIDE/ STATION	WIDTH	LENGTH		RADI	AGGREGATE BASE COURSE, TYPE B		INCIDENTAL HMA SURFACING	AGGREGATE SURFACE COURSE, TYPE B	AGGREGATE SURFACE COURSE, TYPE A	P.C.C. DRIVEWAY PAVEMENT	
			L ₁	L ₂		TON	SO. YD.				TON	TON
PE	RT 862+43	12	20	18	20	24		11.7				
FE	RT 868+00	20	20	18	20		23					
FE	LT 868+39	20	20	21	20		26					
PE	RT 869+43	24	20	18	20	41		20.2				
CE	RT 872+42	35	30	13			200	22.4				
FE	LT 872+46	24	20	26	20		36					
PE	RT 873+44	35	20	23	20	64		31.3				
PE	RT 879+02	18	20	8	20	26		12.6				
CE	RT 880+60	24	30	0	30		117	13.1				
CE	RT 2000+52	24	30	4	20		91	10.2				
CE	LT 2002+27	24	26	20	20		107	12.0				
CE	RT 2002+89	35	30	11	30		184	20.6				
	TOTALS					155	699	85	154.1			

NOTES

L₁ = DISTANCE FROM EDGE OF PAVEMENT TO RADIUS POINT OR MAXIMUM DISTANCE OF 30'.
 L₂ = DISTANCE FROM RADIUS POINT OR MAXIMUM DISTANCE OF 30' FROM EDGE OF PAVEMENT TO R.O.W. LINE
 MATERIAL USED TO CONSTRUCT L₂ LENGTH SHALL BE THE SAME TYPE OF MATERIAL AS THE EXISTING ENTRANCE

THE THICKNESS OF THE HOT-MIX ASPHALT SHOULDERS THROUGH COMMERCIAL ENTRANCES (HOT-MIX ASPHALT) AND PUBLIC ROADS SHALL BE 10". THE COST OF THE EXTRA THICKNESS SHALL BE INCLUDED WITH THE HOT-MIX ASPHALT SHOULDERS PAY ITEM.

THE COST OF THE BITUMINOUS MATERIALS AND AGGREGATE (PRIME COAT) FOR ENTRANCES AND PUBLIC ROAD APPROACHES SHALL BE INCLUDED IN THE PAY ITEM INCIDENTAL HOT-MIX ASPHALT SURFACING.

HOT-MIX ASPHALT SHOULDERS SHALL NOT BE CONSTRUCTED THROUGH PCC ENTRANCE OR PUBLIC ROAD APPROACH.

FE=FIELD ENTRANCE PRA - PUBLIC ROAD APPROACH
 PE=PRIVATE ENTRANCE MBT - MAILBOX TURNOUT
 CE=COMMERCIAL ENTRANCE

FILE NAME =	USER NAME = steffenk	DESIGNED - ---	REVISED - 03-13-07
es:\pw\work\p\dot\steffenk\d0121426\074052-shr-detail.dgn		DRAWN - ---	REVISED - ---
		CHECKED - ---	REVISED - ---
		DATE - ---	REVISED - ---

**STATE OF ILLINOIS
DEPARTMENT OF TRANSPORTATION**

**ENTRANCE SCHEDULE AND MAILBOX TURNOUT DETAILS
WITH BASE COURSE WIDENING**

SCALE: NA SHEET NO. 1 OF 1 SHEETS STA. TO STA.

F.A.S. RTE.	SECTION	COUNTY	TOTAL SHEETS	SHEET NO.
2801	102RS-3.103RS-2.102N		84	15
Effingham, Fayette		CONTRACT NO. 74052		
FED. ROAD DIST. NO.		ILLINOIS FED. AID PROJECT		