

UN053

REVISIONS		
NUMBER	BY	DATE

0 1 2
 THIS BAR IS EQUAL TO 2"
 AT FULL SCALE (34X22).

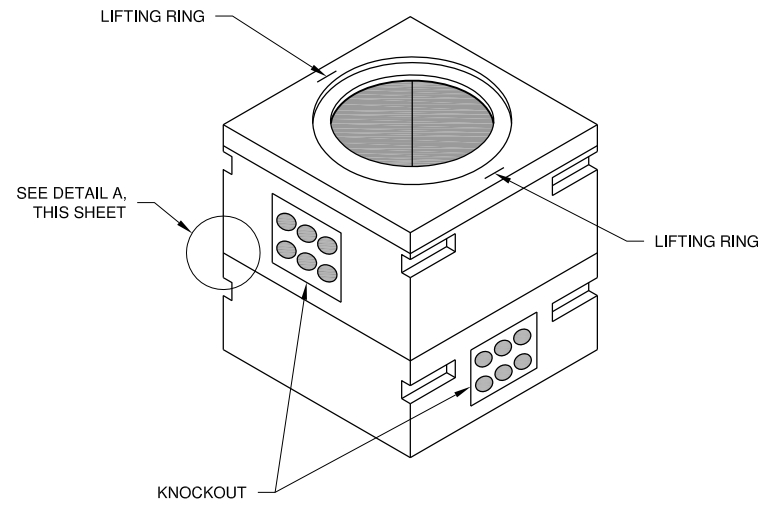

ELEVATION VIEW

NOTES:

1. NO NEW HANDHOLES WILL BE INSTALLED AS PART OF THIS PROJECT. HANDHOLE DETAIL FOR INFORMATION ONLY.

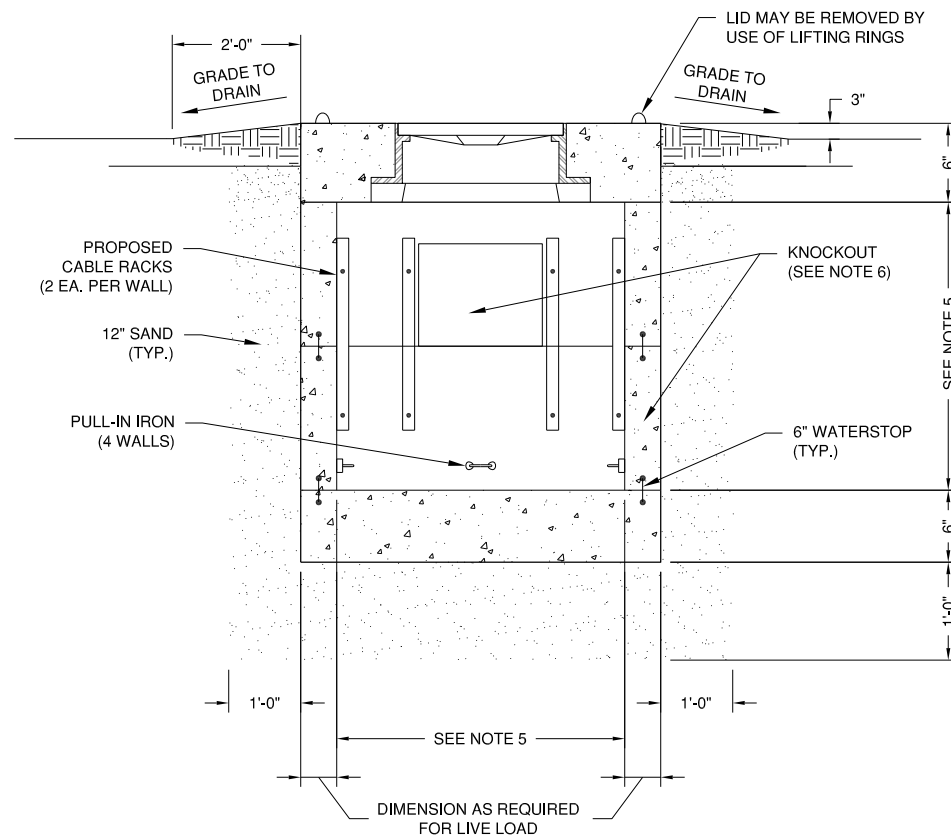

SECTION VIEW

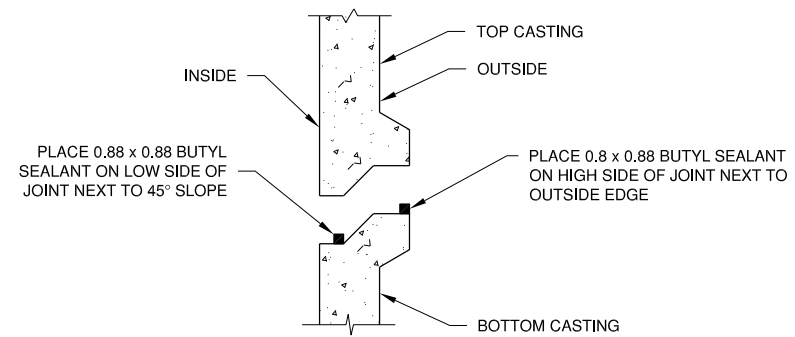

DETAIL A

EXISTING ELECTRICAL HANDHOLE DETAILS

N.T.S.

UNIVERSITY OF ILLINOIS
 WILLARD AIRPORT
 SAVOY, ILLINOIS

BASE BID - REALIGN AND WIDEN TAXIWAY C
 ELECTRICAL DETAILS 4

© Copyright CMT, Inc.

CMT
 CRAWFORD, MURPHY & TILLY, INC.
 CONSULTING ENGINEERS
 License No. 184-000613



DESIGN BY:	CBG
DRAWN BY:	ADD
CHECKED BY:	CET
APPROVED BY:	CET
DATE:	JUNE 27, 2014
JOB No:	13059-02-00

IL PROJ. NO. CMI-4347
 AIP PROJ. NO. 3-17-0016-XX