

CONTROLLER SEQUENCE

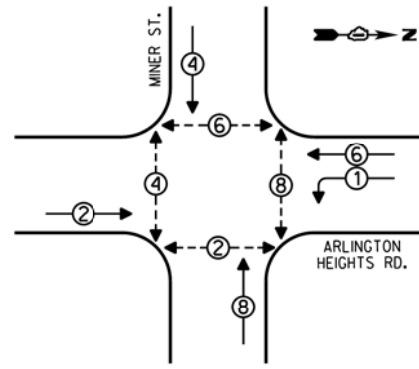

LEGEND
 [Symbol] SINGLE ENTRY PHASE
 [Symbol] DUAL ENTRY PHASE
 [Symbol] OVERLAP
 [Symbol] PEDESTRIAN PHASE
 * NUMBER REFERS TO ASSOCIATED PHASE

PHASE DESIGNATION DIAGRAM

EMERGENCY VEHICLE PREEMPTION SEQUENCE

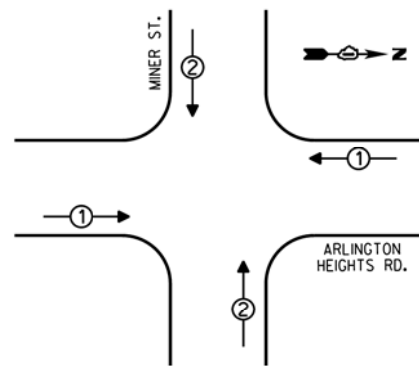

EMERGENCY VEHICLE PREEMPTORS		
EMERGENCY VEHICLE PREEMPTOR	1	2
MOVEMENT	←→	↑↓

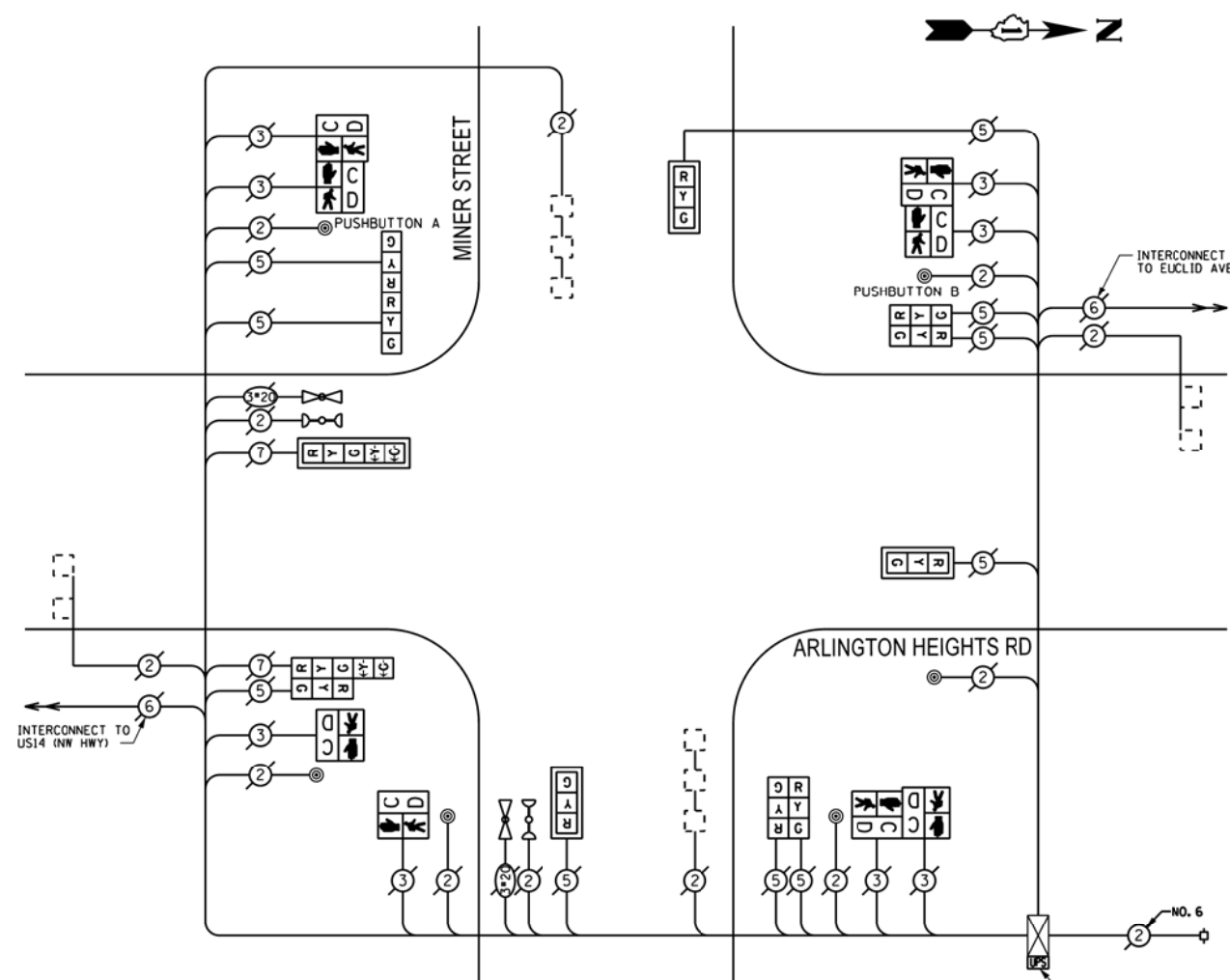

CABLE PLAN

NOTE:
 PUSHBUTTON "A" SHALL PLACE A CALL IN PHASES 4 AND 6
 PUSHBUTTON "B" SHALL PLACE A CALL IN PHASES 6 AND 8

REPLACE ALL EXISTING TRAFFIC SIGNAL HEADS

REPLACE ALL EXISTING PAINTED YELLOW TRAFFIC SIGNAL POSTS ON EXISTING FOUNDATIONS

THE TRAFFIC SIGNAL CONTROL EQUIPMENT FOR THIS PROJECT SHALL BE "ECONOLITE".

I.D.O.T. TRAFFIC SIGNAL INSTALLATION ELECTRICAL SERVICE REQUIREMENTS					TOTAL WATTAGE
TYPE	NO. OF LAMPS	INCAND	LED	% OPERATIONS	
SIGNAL (RED)	12		17	0.50	102.00
(YELLOW)	12		25	0.25	75.00
(GREEN)	12		15	0.25	45.00
ARROW	4		12	0.10	4.80
PED. SIGNAL	8		25	1.00	200.00
CONTROLLER	1		100	1.00	100.00
ILLUM. SIGN			25	0.05	
LUMINAIRE		250		0.50	
VIDEO SYSTEM		150		1.00	
FLASHER				0.50	
ENERGY COSTS TO:					TOTAL = 526.80

VILLAGE OF ARLINGTON HEIGHTS
 33 SOUTH ARLINGTON HEIGHTS ROAD
 ARLINGTON HEIGHTS, ILLINOIS 60005

ENERGY SUPPLY - CONTACT: DAVE SCHACHT
 PHONE: (630) 437-2129
 COMPANY: COMED

REMOVE EXISTING TRAFFIC SIGNAL EQUIPMENT

THE FOLLOWING ITEMS SHALL BE REMOVED BY THE CONTRACTOR AND SHALL BE DISPOSED OF BY THEM OUTSIDE THE RIGHT-OF-WAY AT THEIR EXPENSE. THE SALVAGE VALUE OF THE REMOVED EQUIPMENT SHALL BE REFLECTED IN THE CONTRACT BID PRICE.

QUANTITY	UNIT	DESCRIPTION
2	EACH	TRAFFIC SIGNAL POST
3	EACH	SIGNAL HEAD, 1-FACE, 3-SECTION
1	EACH	SIGNAL HEAD, 1-FACE, 5-SECTION
3	EACH	SIGNAL HEAD, 2-FACE, 3-SECTION
1	EACH	SIGNAL HEAD, 2-FACE, 1-3 SECTION, 1-5 SECTION
2	EACH	PEDESTRIAN SIGNAL HEAD, 1-FACE
3	EACH	PEDESTRIAN SIGNAL HEAD, 2-FACE
6	EACH	PEDESTRIAN PUSHBUTTON

SCHEDULE OF QUANTITIES

QUAN.	UNIT	ITEM
1	EACH	MAINTENANCE OF EXISTING TRAFFIC SIGNAL INSTALLATION
1	EACH	UNINTERRUPTIBLE POWER SUPPLY, SPECIAL
1	EACH	TRAFFIC SIGNAL POST, GALVANIZED STEEL 14 FT.
1	EACH	TRAFFIC SIGNAL POST, GALVANIZED STEEL 16 FT.
3	EACH	SIGNAL HEAD, LED, 1-FACE, 3-SECTION, MAST ARM MOUNTED
1	EACH	SIGNAL HEAD, LED, 1-FACE, 5-SECTION, MAST ARM MOUNTED
3	EACH	SIGNAL HEAD, LED, 2-FACE, 3-SECTION, BRACKET MOUNTED
1	EACH	SIGNAL HEAD, LED, 2-FACE, 1-3 SECTION, 1-5 SECTION, BRACKET MOUNTED
2	EACH	PEDESTRIAN SIGNAL HEAD, LED, 1-FACE, BRACKET MOUNTED WITH COUNTDOWN TIMER
3	EACH	PEDESTRIAN SIGNAL HEAD, LED, 2-FACE, BRACKET MOUNTED WITH COUNTDOWN TIMER
4	EACH	TRAFFIC SIGNAL BACKPLATE
6	EACH	PEDESTRIAN PUSH-BUTTON
1	EACH	MODIFY EXISTING CONTROLLER CABINET
1	EACH	REMOVE EXISTING TRAFFIC SIGNAL EQUIPMENT

FILE NAME =	USER NAME = #USER#	DESIGNED -	REVISED -
#FILE#		DRAWN -	REVISED -
	PLOT SCALE = #SCALE#	CHECKED -	REVISED -
#MODELNAME#	PLOT DATE = #DATE#	DATE -	REVISED -

STATE OF ILLINOIS
 DEPARTMENT OF TRANSPORTATION

SCHEDULE OF QUANTITIES, CABLE PLAN, PHASE DESIGNATION
 DIAGRAM, AND EMERGENCY VEHICLE PREEMPTION SEQUENCE,
 ARLINGTON HEIGHTS ROAD AT MINER STREET

SCALE: NONE SHEET OF SHEETS STA. TO STA.

F.A. RTE.	SECTION	COUNTY	TOTAL SHEETS	SHEET NO.
VAR	2013-005-1	COOK	85	17
			CONTRACT NO. 60W23	
ILLINOIS FED. AID PROJECT				