

CONTROLLER SEQUENCE

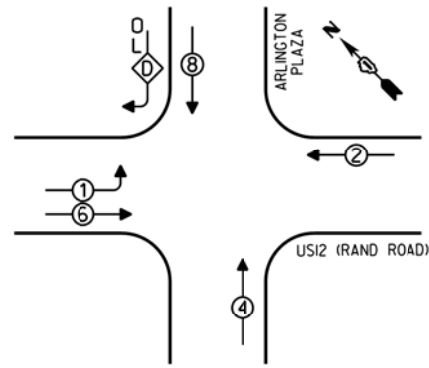

- LEGEND**
- SINGLE ENTRY PHASE
 - DUAL ENTRY PHASE
 - ◇ OVERLAP
 - ⊕ PEDESTRIAN PHASE
 - NUMBER REFERS TO ASSOCIATED PHASE

PHASE DESIGNATION DIAGRAM

OVERLAP LETTER	PERMISSIVE PHASE	PROTECTED PHASE
D	= 8	+ 1

EMERGENCY VEHICLE PREEMPTION SEQUENCE

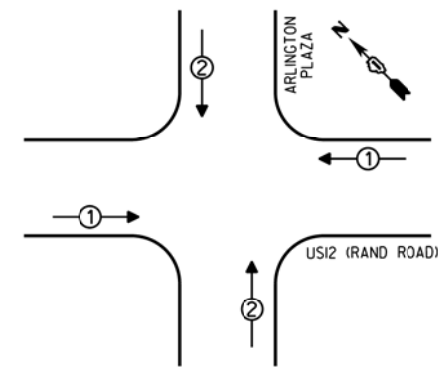

EMERGENCY VEHICLE PREEMPTORS		
EMERGENCY VEHICLE PREEMPTOR	1	2
MOVEMENT	↔	↕

REPLACE ALL EXISTING TRAFFIC SIGNAL HEADS

REPLACE ALL EXISTING PAINTED YELLOW TRAFFIC SIGNAL POSTS ON EXISTING FOUNDATIONS

THE TRAFFIC SIGNAL CONTROL EQUIPMENT FOR THIS PROJECT SHALL BE "ECONOLITE".

INTERSECTION & SAMPLING (SYSTEM) DETECTORS

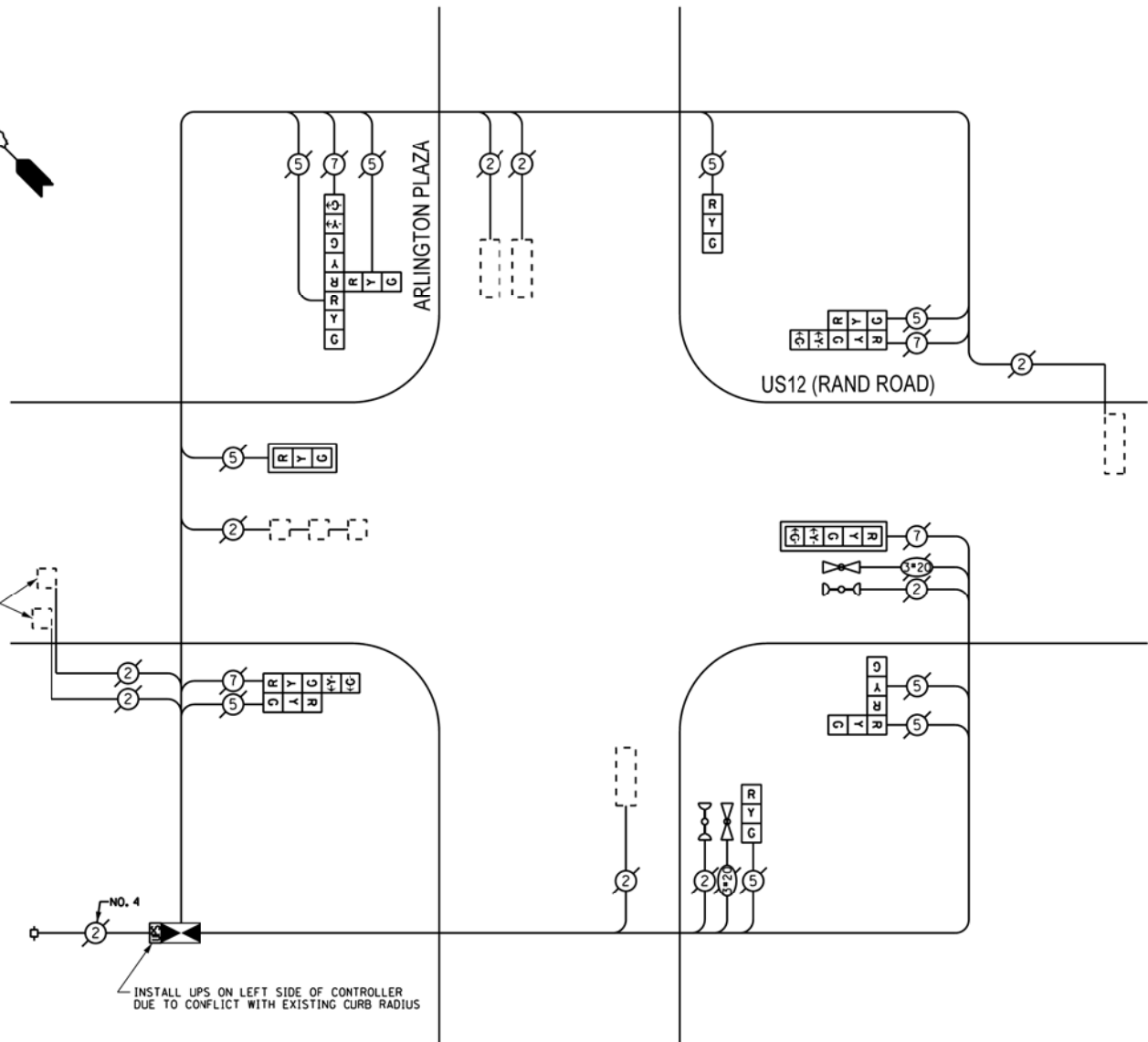

CABLE PLAN

INSTALL UPS ON LEFT SIDE OF CONTROLLER DUE TO CONFLICT WITH EXISTING CURB RADIUS

I.D.O.T. TRAFFIC SIGNAL INSTALLATION ELECTRICAL SERVICE REQUIREMENTS					TOTAL WATTAGE
TYPE	NO. OF LAMPS	INCAND	LED % OPERATIONS	WATTAGE	
SIGNAL (RED)	13		17	0.50	110.50
(YELLOW)	13		25	0.25	81.25
(GREEN)	13		15	0.25	48.75
ARROW	8		12	0.10	9.60
PED. SIGNAL			25	1.00	
CONTROLLER	1		100	1.00	100.00
ILLUM. SIGN			25	0.05	
LUMINAIRE		250		0.50	
VIDEO SYSTEM		150		1.00	
FLASHER				0.50	
ENERGY COSTS TO:				TOTAL =	350.10

VILLAGE OF ARLINGTON HEIGHTS
33 SOUTH ARLINGTON HEIGHTS ROAD
ARLINGTON HEIGHTS, ILLINOIS 60005

ENERGY SUPPLY - CONTACT: DAVE SCHACHT
PHONE: (630) 437-2129
COMPANY: COMED

REMOVE EXISTING TRAFFIC SIGNAL EQUIPMENT

THE FOLLOWING ITEMS SHALL BE REMOVED BY THE CONTRACTOR AND SHALL BE DISPOSED OF BY THEM OUTSIDE THE RIGHT-OF-WAY AT THEIR EXPENSE. THE SALVAGE VALUE OF THE REMOVED EQUIPMENT SHALL BE REFLECTED IN THE CONTRACT BID PRICE.

QUANTITY	UNIT	DESCRIPTION
1	EACH	CONTROLLER AND CABINET (COMPLETE)
4	EACH	TRAFFIC SIGNAL POST
3	EACH	SIGNAL HEAD, 1-FACE, 3-SECTION
1	EACH	SIGNAL HEAD, 1-FACE, 5-SECTION
1	EACH	SIGNAL HEAD, 2-FACE, 3-SECTION
2	EACH	SIGNAL HEAD, 2-FACE, 1-3 SECTION, 1-5 SECTION
1	EACH	SIGNAL HEAD, 3-FACE, 2-3 SECTION, 1-5 SECTION

SCHEDULE OF QUANTITIES

QUAN.	UNIT	ITEM
1	EACH	MAINTENANCE OF EXISTING TRAFFIC SIGNAL INSTALLATION
1	EACH	TRAFFIC SIGNAL POST, GALVANIZED STEEL 14 FT.
2	EACH	TRAFFIC SIGNAL POST, GALVANIZED STEEL 16 FT.
1	EACH	TRAFFIC SIGNAL POST, GALVANIZED STEEL 18 FT.
1	EACH	SIGNAL HEAD, LED, 1-FACE, 3-SECTION, MAST ARM MOUNTED
2	EACH	SIGNAL HEAD, LED, 1-FACE, 3-SECTION, BRACKET MOUNTED
1	EACH	SIGNAL HEAD, LED, 1-FACE, 5-SECTION, MAST ARM MOUNTED
1	EACH	SIGNAL HEAD, LED, 2-FACE, 3-SECTION, BRACKET MOUNTED
2	EACH	SIGNAL HEAD, LED, 2-FACE, 1-3 SECTION, 1-5 SECTION, BRACKET MOUNTED
1	EACH	SIGNAL HEAD, LED, 3-FACE, 2-3 SECTION, 1-5 SECTION, BRACKET MOUNTED
2	EACH	TRAFFIC SIGNAL BACKPLATE
1	EACH	RELOCATE EXISTING EMERGENCY VEHICLE PRIORITY SYSTEM, DETECTOR UNIT
1	EACH	FULL ACTUATED CONTROLLER AND TYPE IV CABINET (SPECIAL)
1	EACH	REMOVE EXISTING TRAFFIC SIGNAL EQUIPMENT
1	EACH	UNINTERRUPTIBLE POWER SUPPLY, SPECIAL

FILE NAME =	USER NAME = #USER#	DESIGNED -	REVISED -
#FILE#		DRAWN -	REVISED -
	PLOT SCALE = #SCALE#	CHECKED -	REVISED -
#MODELNAME#	PLOT DATE = #DATE#	DATE -	REVISED -

STATE OF ILLINOIS
DEPARTMENT OF TRANSPORTATION

SCHEDULE OF QUANTITIES, CABLE PLAN, PHASE DESIGNATION
DIAGRAM, AND EMERGENCY VEHICLE PREEMPTION SEQUENCE,
US12 (RAND ROAD) AT ARLINGTON PLAZA

SCALE: NONE SHEET OF SHEETS STA. TO STA.

F.A. RTE.	SECTION	COUNTY	TOTAL SHEETS	SHEET NO.
VAR	2013-005-1	COOK	85	39
			CONTRACT NO. 60W23	
ILLINOIS FED. AID PROJECT				