

- NOTES:**
1. ALL DIMENSIONS ARE IN INCHES (MILLIMETERS) UNLESS OTHERWISE SHOWN.
  2. MOUNTING HEIGHT IS DEFINED AS THE DISTANCE FROM THE CENTERLINE OF THE TENON TO THE BOTTOM OF THE ANCHOR BASE.
  3. TWO PIECE SHAFT WILL BE MATCHED MARKED AND INTERCHANGEABLE BETWEEN DIFFERENT UNITS. FIELD DRILLING OF THE HOLES WILL NOT BE ALLOWED.
  4. THE LIGHT POLE WILL MEET AASHTO DESIGN CRITERIA AS SPECIFIED.
  5. THE INSTALLING CONTRACTOR WILL PROVIDE A UL LISTED GROUNDING CONNECTOR, BURNDY K2C23, T&B SP4DL OR APPROVED EQUAL.
  6. LIGHT POLES WILL NOT BE INSTALLED WITHOUT MAST ARMS AND LUMINAIRES.
  7. LIGHT POLES WILL BE SET PLUMB ON THE FOUNDATION WITHOUT THE USE OF LEVELING NUTS, WASHERS OR SHIMS.
  8. LIGHTING UNIT IDENTIFICATION NUMBERS SHALL BE INSTALLED BEFORE THE LIGHTING UNIT IS ENERGIZED.

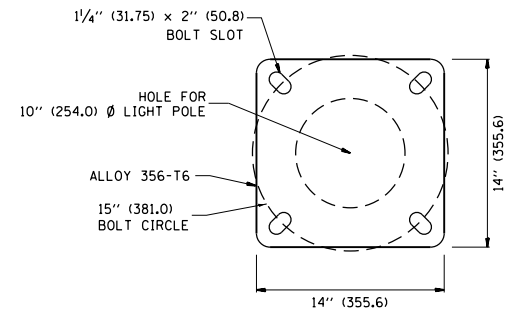

**LIGHT POLE BASE PLATE DETAIL**  
15 INCH (381.0) BOLT CIRCLE

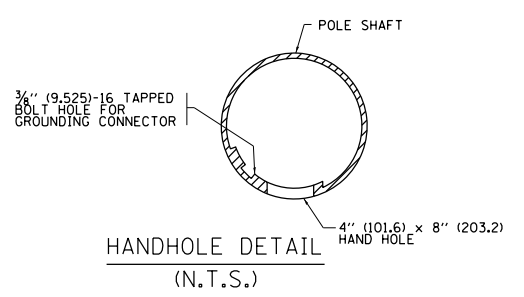

FILE NAME =	USER NAME = pteip2	DESIGNED -	REVISED - R. TOMSONS 09-06-00
pw:\388039-pw\l\ecom\lne\local\p\AE\COM\Documents\01 Americas\Transportation\0000\Drawn\CirclePhase_11\000\CAD\006_Road\REVISED_60W25_R\TOMSONS_09-08-03_Detail-11.dgn		CHECKED -	REVISED -
PLOT SCALE = 50.000' / in.		DATE -	REVISED -
PLOT DATE = 5/15/2013			

**STATE OF ILLINOIS**  
**DEPARTMENT OF TRANSPORTATION**

<b>ALUMINUM LIGHT POLE</b>			
<b>47'-6" (14.478 m) MOUNTING HEIGHT</b>			
SCALE: NONE	SHEET NO. 11 OF 31 SHEETS	STA.	TO STA.

F.A.I. RTE.	SECTION	COUNTY	TOTAL SHEETS	SHEET NO.
	2013-007R	COOK	317	243
<b>BE-400</b>		<b>CONTRACT NO. 60W25</b>		
FED. ROAD DIST. NO. 1 ILLINOIS FED. AID PROJECT				
• 90/94/290				