

NOTES:
 DETAIL NUMBERS INDICATE NO. OF CABLES.

TRENCHES WITH MORE THAN SEVEN CABLES SHALL BE INCREASED 3" IN WIDTH FOR EACH ADDITIONAL CABLE; IF SPECIFIED ON PLANS TWO PARALLEL TRENCHES MAY BE CONSTRUCTED.

DEPTH OF TRENCHES SHALL BE AS SHOWN ABOVE UNLESS OTHERWISE SPECIFIED ON THE PLANS.

ALL DISTURBED SURFACES SHALL BE RESTORED TO THEIR ORIGINAL CONDITION. COST IS INCIDENTAL TO TRENCH.

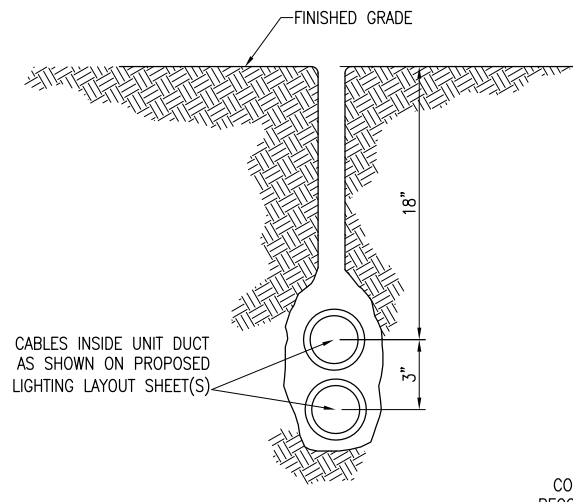

PLOWED CABLE
(NOT TO SCALE)

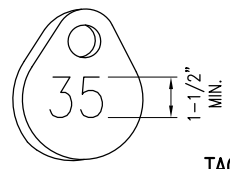

TAG DETAIL
(NOT TO SCALE)

NOTE:
 AFFIX NON-CORROSIVE TAG TO FIXTURE FACING RUNWAY WITH SET SCREW, WIRE TIE, OR METAL BAND. NUMERALS SHALL BE ENGRAVED FOR PERMANENT READABILITY.

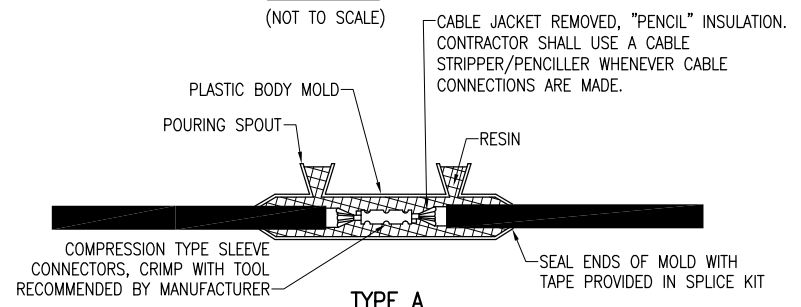

TYPE A

CONTINUOUS HEAT SHRINK TUBING PLACED OVER THE ENTIRE L-823 CONNECTOR(S) BOTH MALE AND FEMALE AT ALL 5KV JUNCTIONS. THE HEAT SHRINK TUBING SHALL BE APPROXIMATELY 18" IN LENGTH WITH 6 INCHES OF MASTIC ON BOTH ENDS AND VOID OF MASTIC IN MIDDLE OF TUBE RATED FOR 5KV.

FOR SPLICES IN LOW VOLTAGE CABLE (600V) HOMERUNS FOR EXTENSIONS TO EXISTING LOW VOLTAGE CABLES ONLY. TYPE A SPLICES SHALL BE MADE IN SPLICE CANS, HANDHOLES, MANHOLES, OR JUNCTIONS BOXES

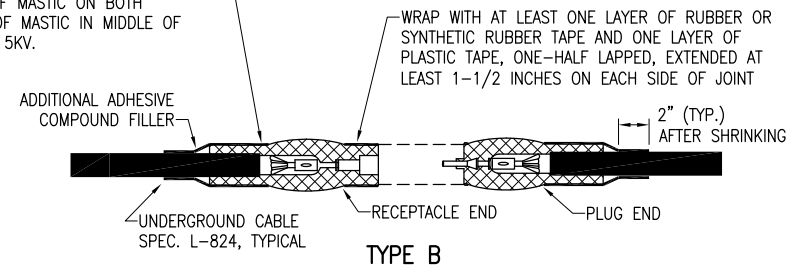

TYPE B

FOR SPLICES AT JUNCTION OF HOMERUN WITH LOOP CIRCUIT AND FOR SPLICES IN HOMERUNS TO EXISTING CABLES

HEAT SHRINKABLE TUBING WITH INTERNAL ADHESIVE. HEAT SHRINKABLE TUBING SHALL EXTEND FROM THE CABLE TO AT LEAST AN INCH PAST THE COMPLETED CONNECTION.

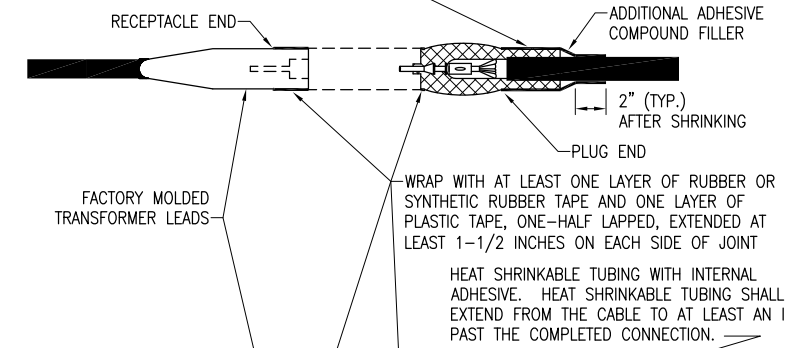

TYPE C

FOR SPLICES AT RUNWAY AND TAXIWAY LIGHTS

NOTES:
 SEE PROPOSED LIGHTING LAYOUT SHEET(S) FOR SPLICE TYPE.

INSIDE DIAMETER OF CONNECTOR SHALL PROPERLY MATCH THE OUTSIDE DIAMETER OF CABLE.

CABLE SPLICES
(NOT TO SCALE)

PER FAA AC 150/5340-30G DESIGN AND INSTALLATION DETAILS FOR AIRPORT VISUAL AIDS, A LIGHT BASE GROUND MUST BE INSTALLED AT EACH STAKE MOUNTED LIGHT AND EACH TRANSFORMER BASE/LIGHT CAN ASSOCIATED WITH RUNWAY LIGHTS, TAXIWAY LIGHTS, AND LIGHTED TAXI GUIDANCE SIGNS. THE LIGHT BASE GROUND SHALL BE A #6 AWG BARE COPPER CONDUCTOR BONDED TO THE GROUND LUG ON THE RESPECTIVE L-867 TRANSFORMER BASE/LIGHT CAN OR MOUNTING STAKE AND A 5/8-INCH DIAMETER BY 8-FOOT LONG (MINIMUM) UL LISTED COPPER CLAD GROUND ROD.

CABLE TRENCHES
(NOT TO SCALE)

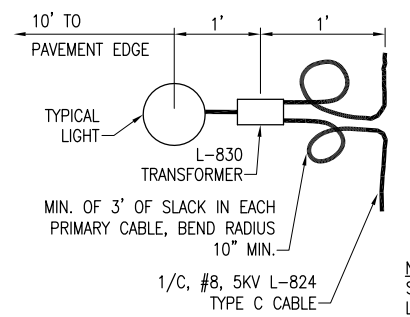

PLAN VIEW

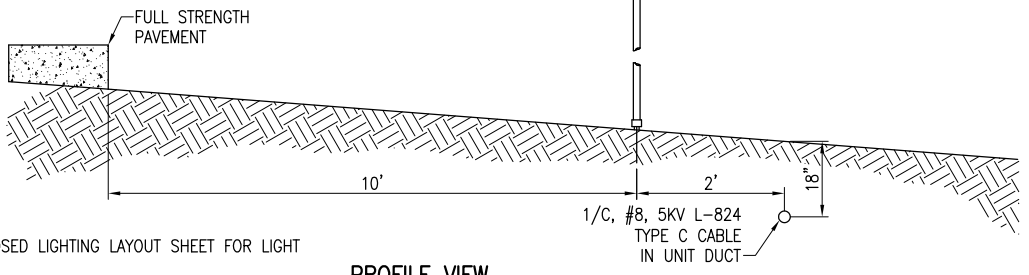

PROFILE VIEW

LIGHT AND CABLE INSTALLATION DETAIL
(NOT TO SCALE)

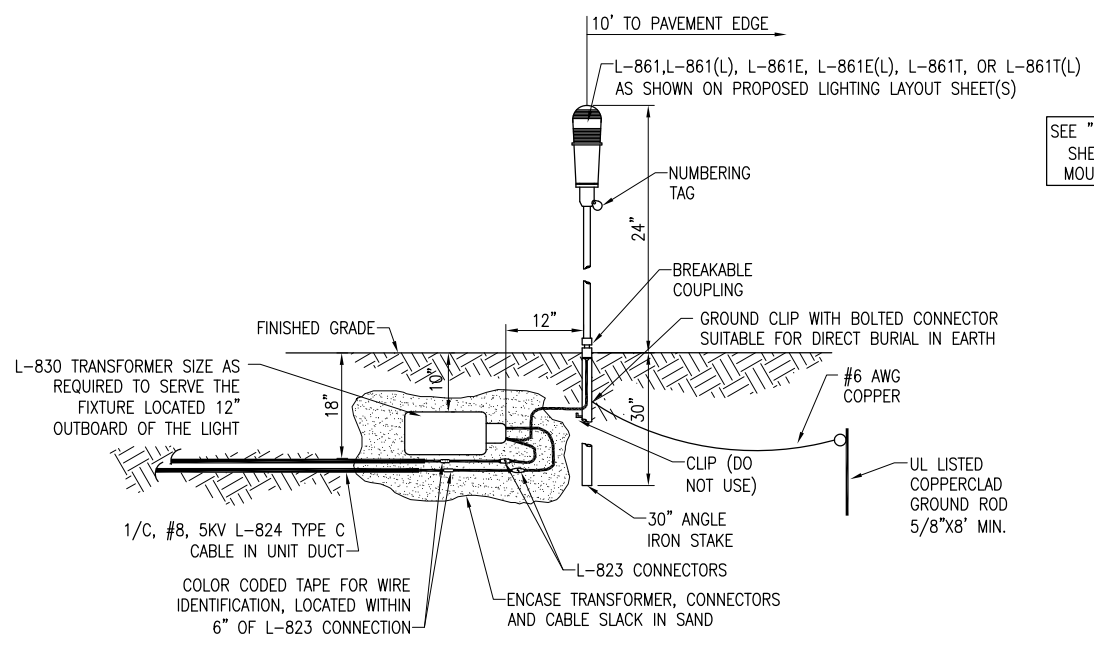

MEDIUM INTENSITY LIGHT - STAKE MOUNTED
(NOT TO SCALE)

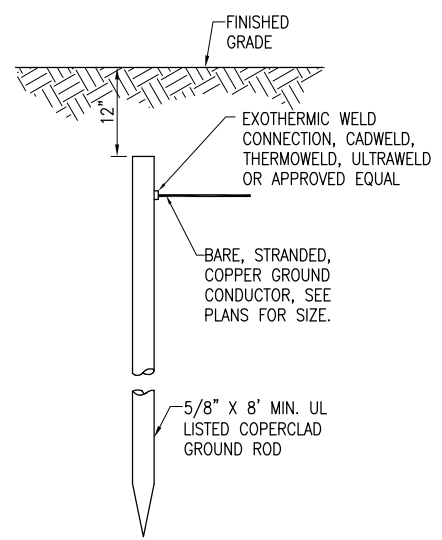

GROUND ROD
(NOT TO SCALE)

NOTES:
 TYPE AND MINIMUM NUMBER OF GROUND RODS SHALL BE AS SPECIFIED ON THE PLAN.

THE RESISTANCE TO GROUND OF THE GROUNDING SYSTEM SHALL NOT EXCEED 25 OHMS.

COST OF GROUND RODS IS INCIDENTAL TO THE ASSOCIATED ITEMS REQUIRING GROUNDING UNLESS OTHERWISE SPECIFIED.

REVISION	
DATE	

MACOMB MUNICIPAL AIRPORT
 MACOMB, ILLINOIS

BLOCK GRANT PROJ.: 3-17-0064-B21
 ILL. PROJ.: MGB-4206

Hanson Proj. No. 12A00533	FILENAME E-501-DETL.dwg	SCALE NOT TO SCALE	DATE 06/17/13
LAYOUT	KNL	01/13/13	
DRAWN	TRR	01/15/13	
REVIEWED	KNL/CAH	02/04/13	



REPLACE VAULT, AIRFIELD LIGHTING AND GUIDANCE SIGNS

ELECTRICAL DETAILS SHEET 1

JUN 17, 2013 12:13 PM HARR01115
 p:\s\svr306\hanson\Documents\12\jobs\12A00533\12A00533\CAD\Airport\Sheet E-501-DETL