

F.A.P. RTE.	SECTION	COUNTY	TOTAL SHEETS	SHEET NO.
335	119R-2	LAKE	439	280
STA. 432+83.12		TO STA. 470+56.84		
FED. ROAD DIST. NO.	ILLINOIS	FED. AID PROJECT		

60B01

NOTES:

1. Tie Rods shall conform to the requirements of AASHTO M 183. Turnbuckles shall be dropped forged and conform to the requirements of AASHTO M 102 (ASTM A 668) Class C. The structural steel, tie rods and turnbuckles shall be hot-dipped galvanized in accordance with AASHTO M 232 (ASTM A.153).
2. The nuts and bolts at the end of the tie rods shall conform to the requirements of AASHTO M 164 (ASTM A 325). The nuts and bolts shall be hot-dipped galvanized in accordance with AASHTO M 232 (ASTM A 153).
3. The tape to be wrapped around tie rods shall be "Tapecoat-CT" or an approved equal.
4. The cost of Furnishing and Installing the tie rods and associated hardware shall be included in the cost of "Permanent Sheet Piling".

CONSTRUCTION SEQUENCE

The tie rods shall be installed in the following sequence unless an alternate sequence is submitted by the Contractor and approved by the Engineer:

1. After the superstructure is in place and formwork has been removed, drive sheet piling 4' minimum into existing ground at locations shown in the plans. The sheet lengths shown in the plans are the minimum required, however the Engineer may elect to increase depth based on existing field conditions. Care shall be taken not to drive the sheets through the pipe underdrain.
2. Place Porous Granular Embankment (Special) behind the abutments in the vicinity of the sheet piling to six inches below the tie rod elevation. The Porous Granular Embankment (Special) shall be placed level in front and back of the sheet for approximately 10 feet minimum before sloping down at a 1 to 1 slope to the bottom of the wingwall elevation. At locations where excavation is necessary to install the tie rods, excavate to 6" below the tie rod elevation.
3. Install wales, tie rods, and turnbuckles. Tighten turnbuckles until tie rod is lightly tensioned. Tensioning should not pull the wingwall reinforcement out of vertical or horizontal alignment. Shim tie rod near middle at support sheet piling.
4. Form, pour, and cure the concrete in the wingwalls.
5. After forms have been removed, backfill on outside of wingwalls to approximate final grade. Place porous granular backfill on the inside of the wingwall to an elevation six inches below the tie rod elevation using care not to place directly on the tie rod.
6. Tighten turnbuckles until sheet piling is aligned. Tension tie rod to a snug fit, back off and re-tighten to a snug fit plus one-quarter turn. Set the threads of the tie rod after the final tightening.
7. Clean, wrap, and protect the tie rod, turnbuckle, and wale anchorage connections in accordance with the tape manufacturer's recommendations.
8. Complete backfill on inside of wingwalls, using care to work fill material around the tie rods. Do not permit mechanical compaction equipment to cross the tie rods until a minimum of one foot of protective backfill has been placed and compacted by alternate methods.

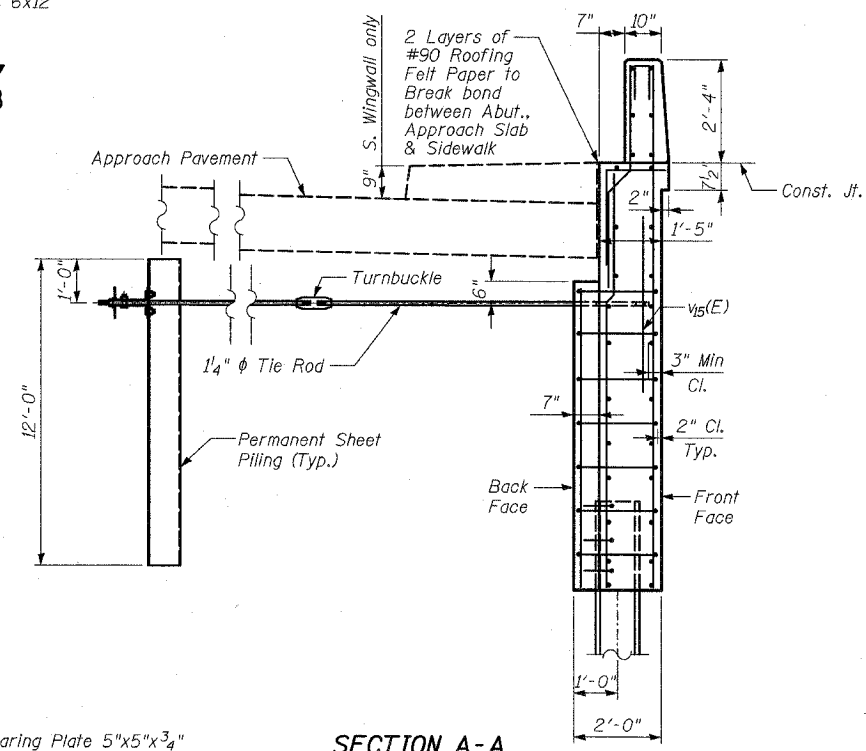
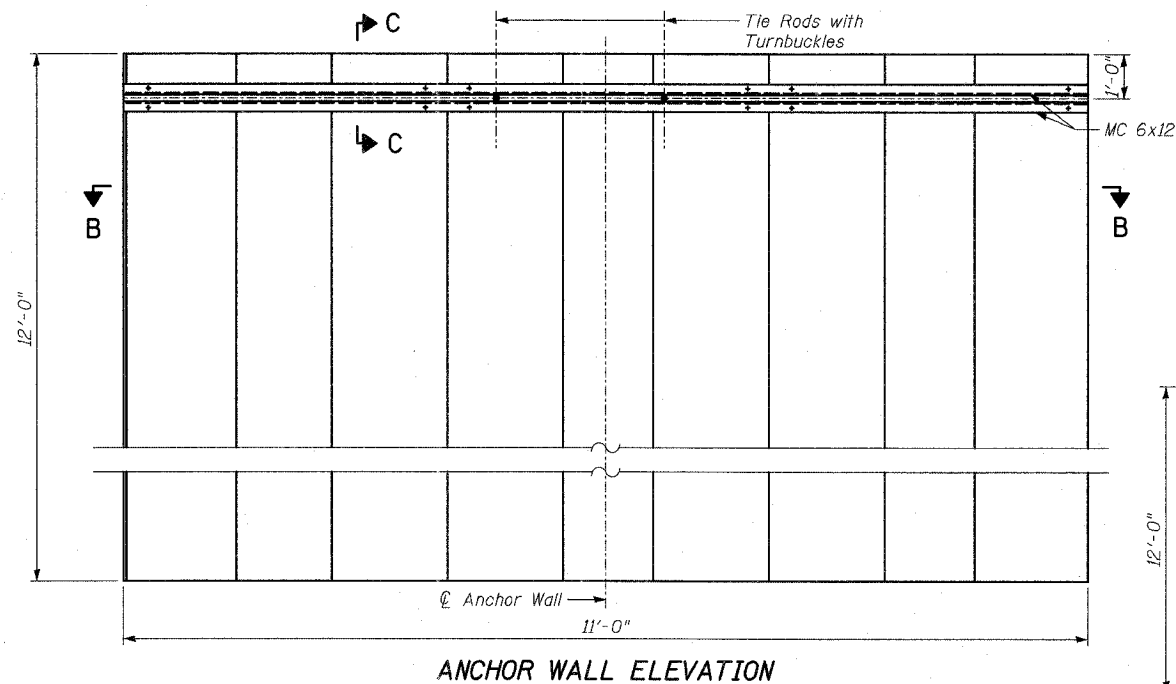

SECTION A-A

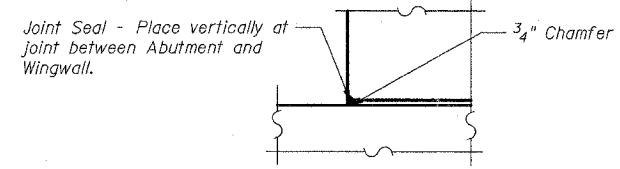

DETAIL A

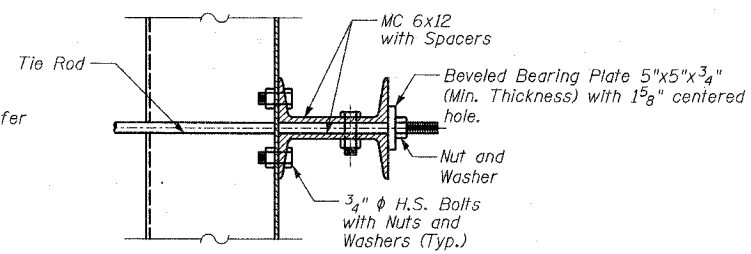

SECTION C-C

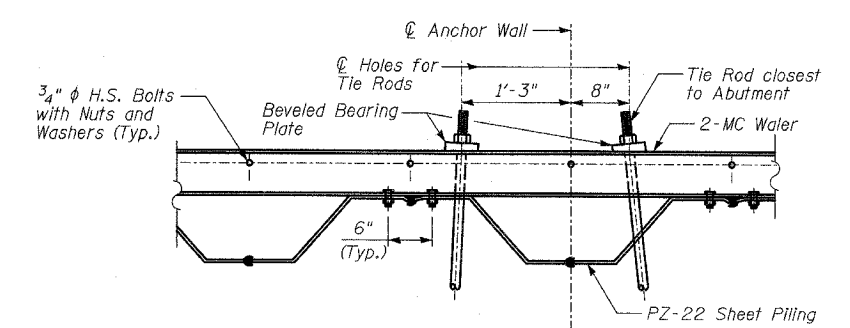

SECTION B-B

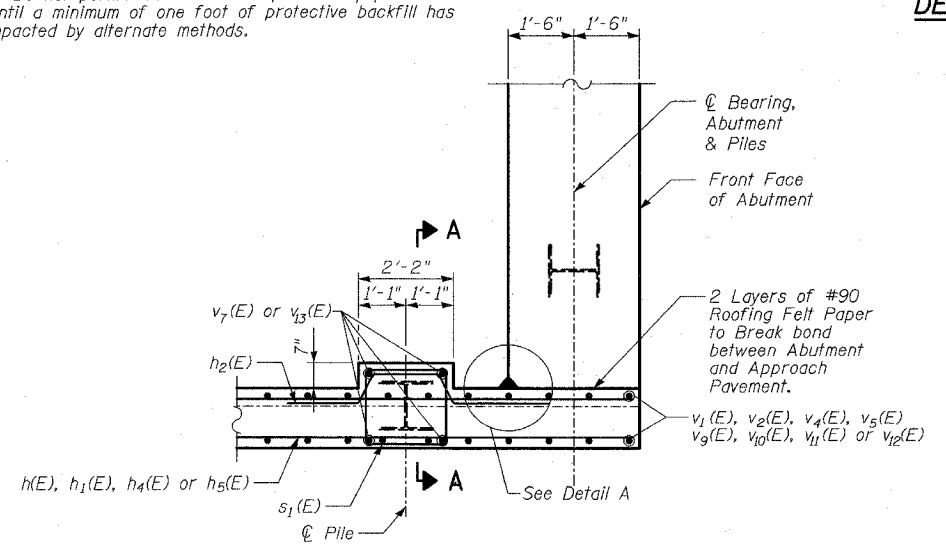

WINGWALL - PLAN

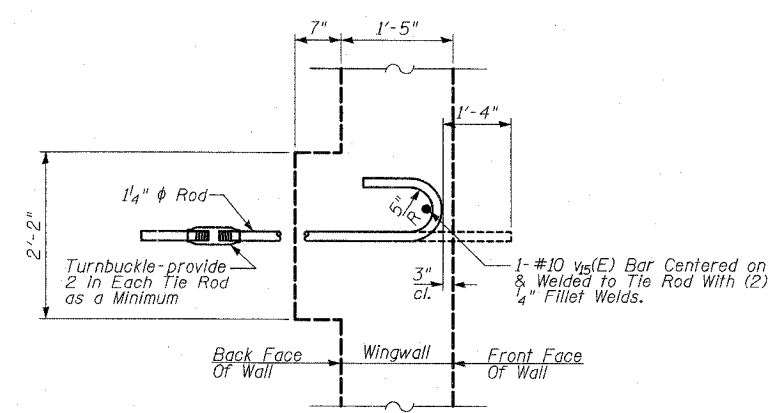

TIE ROD DETAILS - PLAN VIEW

REVISIONS	
NAME	DATE

ILLINOIS DEPARTMENT OF TRANSPORTATION
 ABUTMENT MISCELLANEOUS DETAILS
 ILLINOIS 60 OVER I-94
 F.A.P. RTE. 335 SECTION 119R-2
 LAKE COUNTY STA. 445+54.14
 S.N. 049-2012 ISTHA BRIDGE NO. 407
 DESIGNED BY: TB
 DRAWN BY: TB
 CHECKED BY: SP
 SCALE:
 DATE: MAY 8, 2007

TYLIN INTERNATIONAL

P:\60245811-60\structure\119R-2\60B01.dwg 05/03/2007 04:30:50 PM