

F.A.U. RTE.	SECTION	COUNTY	TOTAL SHEETS	SHEET NO.
9177	44-1BR	ST. CLAIR	46	17
STA.		TO STA.		
FED. ROAD DIST. NO.		ILLINOIS FED. AID PROJECT		

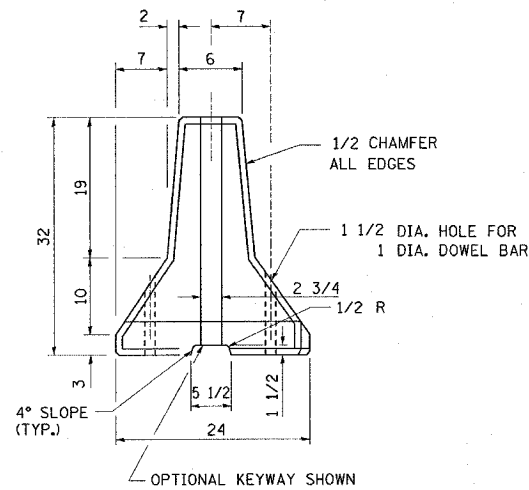

END VIEW
(WITHOUT WIRE ROPE LOOPS)

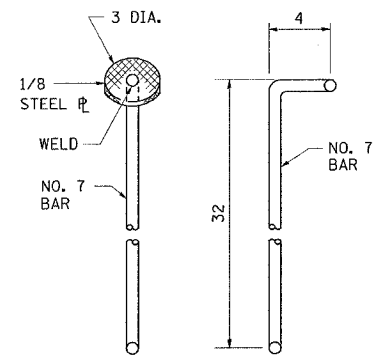

ALTERNATE CONNECTING PINS

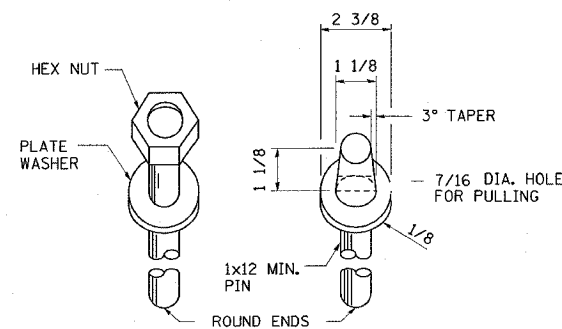

DOWEL BARS

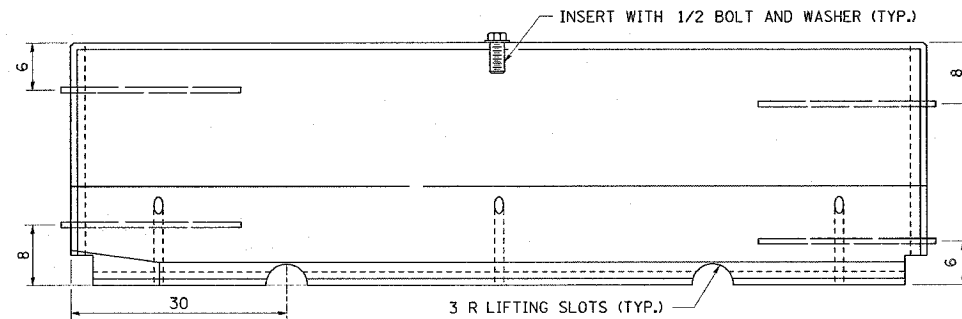

ELEVATION

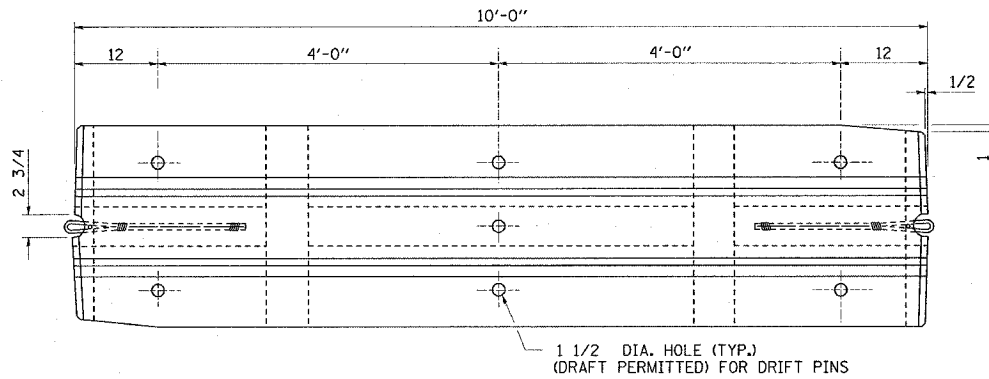

PLAN

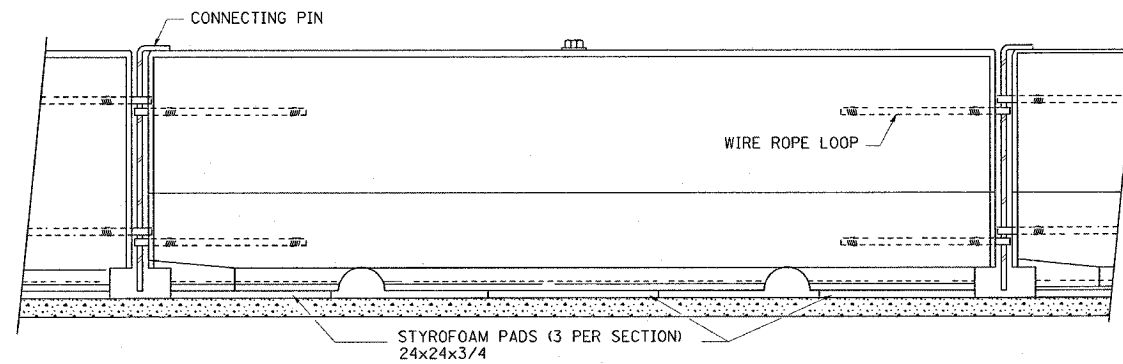

TYPICAL INSTALLATION WITH STYROFOAM PADS

**TEMPORARY CONCRETE BARRIER
NJ SHAPE DESIGN**

NOTES:
NEW JERSEY (NJ) SHAPE BARRIER SHALL NOT BE PRODUCED AFTER OCTOBER 1, 2002. HOWEVER, NEW JERSEY SHAPE BARRIER PRODUCED PRIOR TO OCTOBER 1, 2002 MAY BE USED UNTIL JANUARY 1, 2008.

THE NJ SHAPE BARRIER UNITS SHALL BE SEATED ON STYROFOAM PADS EXCEPT WHEN THEY ARE ANCHORED.

NJ SHAPE DOWEL BARS SHALL BE EMBEDDED AT LEAST 8 INCHES INTO THE PAVEMENT, AND SHALL NOT PROJECT ABOVE THE OUTER SURFACE OF THE BARRIER. THE CONNECTING PIN FOR THE NJ SHAPE PIN AND LOOP CONNECTION, MAY BE EITHER A PLAIN 7/8 INCH DIAMETER OR A DEFORMED NO. 7 BAR MEETING THE REQUIREMENTS OF ARTICLE 1006.10(b) EXCEPT GRADE 60 BARS SHALL BE USED.

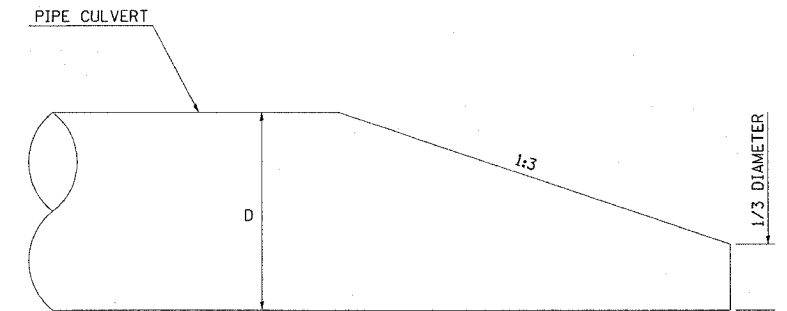

D = DIAMETER OF PIPE

CULVERT BEVELLED END SECTION DETAIL

THE BEVELLED END PORTION SHALL BE INCLUDED IN THE UNIT PRICE PER FOOT FOR THE PIPE

ALL DIMENSIONS ARE IN INCHES UNLESS OTHERWISE SHOWN.

REVISIONS	
NAME	DATE

ILLINOIS DEPARTMENT OF TRANSPORTATION

MISCELLANEOUS DETAILS

FAU ROUTE 9079
SECTION 65BR
MADISON COUNTY
SN 060-0069 (E) 0236 (P)