

**NOTES**

Bar splicer assemblies shall be of an approved type and shall develop in tension at least 125 percent of the yield strength of the lapped reinforcement bars.  
 Splicer rods shall be of minimum 60 ksi yield strength, threaded or coiled full length.  
 All reinforcement bars shall be lapped and tied to the splicer rods or dowel bars.  
 Bar splicer assemblies shall be epoxy coated according to the requirements for reinforcement bars.  
 Other systems of similar design may be submitted to the Engineer for approval. Approval shall be based on certified test results from an approved testing laboratory that the proposed bar splicer assembly satisfies the following requirements:

- ① Minimum Capacity =  $1.25 \times f_y \times A_t$   
(Tension in kips)
  - ② Minimum \*Pull-out Strength =  $0.66 \times f_y \times A_t$   
(Tension in kips)
- Where  $f_y$  = Yield strength of lapped reinforcement bars in ksi.  
 $A_t$  = Tensile stress area of lapped reinforcement bars.  
 \* = 28 day concrete

BAR SPLICER ASSEMBLIES			
Bar Size to be Spliced	Splicer Rod or Dowel Bar Length	Strength Requirements	
		Min. Capacity kips - tension	Min. Pull-Out Strength kips - tension
#4	1'-8"	14.7	7.9
#5	2'-0"	23.0	12.3
#6	2'-7"	33.1	17.4
#7	3'-5"	45.1	23.8
#8	4'-6"	58.9	31.3
#9	5'-9"	75.0	39.6
#10	7'-3"	95.0	50.3
#11	9'-0"	117.4	61.8

The diameter of this part is equal or larger than the diameter of bar spliced.

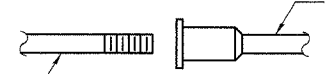

**ROLLED THREAD DOWEL BAR**



**\*\* ONE PIECE**

Wire Connector

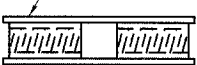

**WELDED SECTIONS**

**BAR SPLICER ASSEMBLY ALTERNATIVES**

\*\* Heavy Hex Nuts conforming to ASTM A 563, Grade C, D or DH may be used.

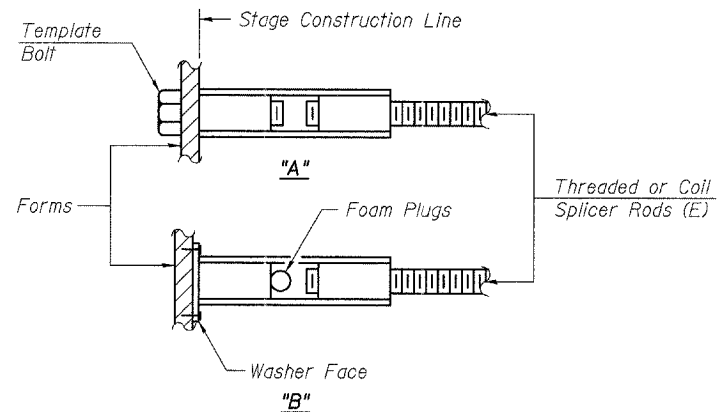

**INSTALLATION AND SETTING METHODS**

"A" : Set bar splicer assembly by means of a template bolt.  
 "B" : Set bar splicer assembly by nailing to wood forms or cementing to steel forms.  
 (E) : Indicates epoxy coating.

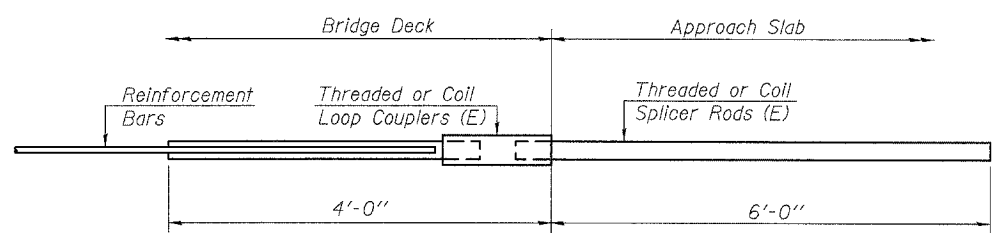

**FOR INTEGRAL OR SEMI-INTEGRAL ABUTMENTS**

Bar Splicer for #5 bar
Min. Capacity = 23.0 kips - tension
Min. Pull-out Strength = 12.3 kips - tension
No. Required = 84

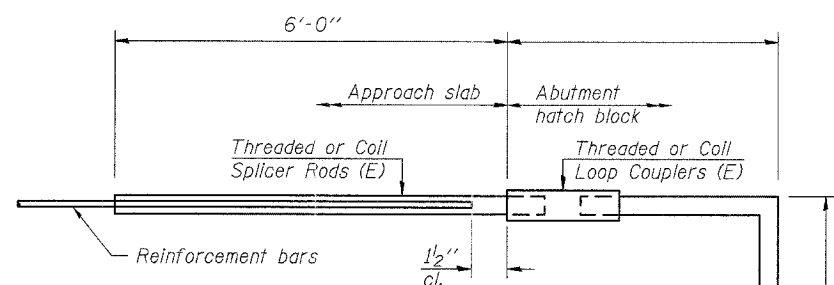

**FOR STUB ABUTMENTS**

Bar Splicer for #5 bar
Min. Capacity = 23.0 kips - tension
Min. Pull-out Strength = 12.3 kips - tension
No. Required =

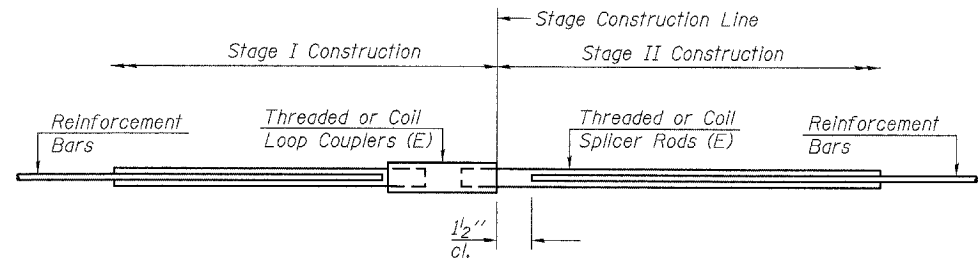

**STANDARD**

Bar Size	No. Assemblies Required	Location
#5	245	Deck
#6	14	Diaphragms
#7	24	Abutments

ILLINOIS DEPARTMENT OF TRANSPORTATION  
**BAR SPLICER ASSEMBLY DETAILS**  
 ILLINOIS ROUTE 14 OVER  
 ANDY CREEK  
 F.A.P. ROUTE 869 - SECTION 104B-2  
 FRANKLIN COUNTY  
 STATION 603+80.00  
 STRUCTURE NO. 028-0076

**LIN ENGINEERING, LTD.**  
 Consulting Engineers  
 Chatham, Illinois

Designed By: JBY    Checked By: MTH    Drawn By: AJF  
 Date: 12/06    File: 028-0076.DGN

REVISIONS	
NAME	DATE

E:\0602\Plans\028-0076.dgn 2:59:04 PM 5/7/2007