

NOTE: ALL WORK IS WITHIN EXISTING ROW

PROPOSED TYPICAL SECTION

STA. 28+49 TO STA. 34+99, MAPLE AVENUE
 STA. 34+99 TO STA. 36+35, MAPLE AVENUE TAPER SECTION

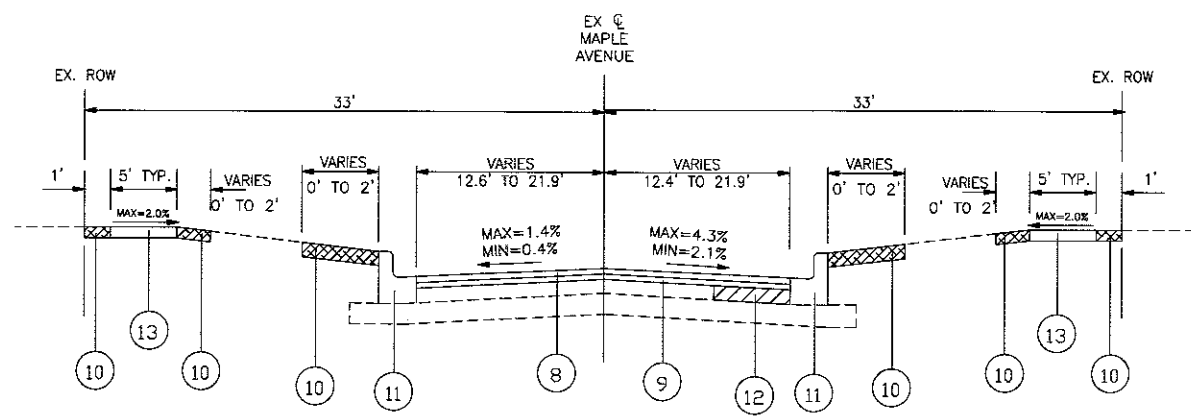

NOTE: ALL WORK IS WITHIN EXISTING ROW

PROPOSED TYPICAL SECTION

STA. 36+35 TO STA. 39+00, MAPLE AVENUE TAPER SECTION
 STA. 39+00 TO STA. 61+75, MAPLE AVENUE

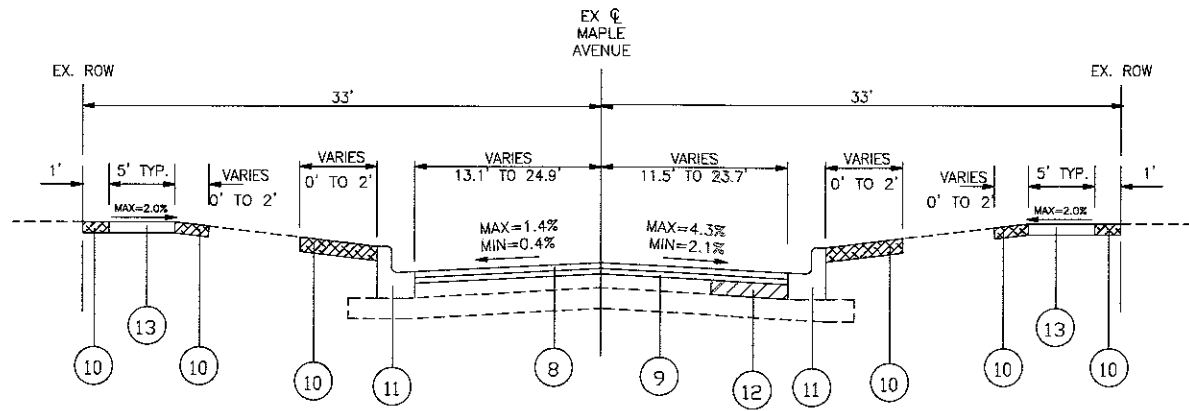

NOTE: ALL WORK IS WITHIN EXISTING ROW

PROPOSED TYPICAL SECTION

STA. 65+87 TO STA. 71+20, MAPLE AVENUE
 STA. 71+20 TO STA. 71+69, MAPLE AVENUE TAPER SECTION
 STA. 71+69 TO STA. 74+57, MAPLE AVENUE

LEGEND

- ⑧ PROPOSED HMA SURFACE COURSE, MIX "D", N50, 1 1/2"
- ⑨ PROPOSED POLYMERIZED LEVELING BINDER (MACHINE METHOD), IL-4.75, N50, 3/4"
- ⑩ PROPOSED SODDING, SALT TOLERANT & TOP SOIL FURNISH AND PLACE, 4" (LOCATIONS DETERMINED BY ENGINEER)
- ⑪ PROPOSED COMBINATION CONCRETE CURB & GUTTER, TYPE B6.12 REPLACEMENT, WHERE SHOWN ON PLANS AND AS DETERMINED IN THE FIELD BY ENGINEER
- ⑫ CLASS D PATCH (LOCATION AND DIMENSIONS DETERMINED BY ENGINEER), 4" OR 6"
- ⑬ PROPOSED PORTLAND CEMENT CONCRETE SIDEWALK, WHERE SHOWN ON PLAN AND AS DETERMINED IN THE FIELD BY ENGINEER

HATCH LEGEND

REMOVAL ITEMS

NOTE OF NO IMPROVEMENTS INCLUDED IN THIS CONTRACT:
 OMISSION STA. 61+75 TO STA. 65+87, MAPLE AVENUE

CONTRACTOR SHALL MILL FIRST BEFORE PATCHING

HOT-MIX ASPHALT MIXTURE REQUIREMENTS	
MIXTURE TYPE	AIR VOIDS @ Ndes
ROADWAYS:	
HOT-MIX ASPHALT SURFACE COURSE, MIX "D", N50 (IL 9.5 mm), 1 1/2"	4% @ 50 GYR
POLYMERIZED LEVELING BINDER (MACHINE METHOD), IL-4.75, N50, 3/4"	3.5% @ 50 GYR
DRIVEWAYS:	
HOT-MIX ASPHALT SURFACE COURSE, MIX "D" N50 (IL 9.5 mm) - 3"	4% @ 50 GYR
PATCHING:	
CLASS D PATCHES, (HMA BINDER) IL-19mm, N70, 4" (IN 2 LIFTS)	4% @ 70 GYR
CLASS D PATCHES, (HMA BINDER) IL-19mm, N70, 6" (IN 2 LIFTS)	4% @ 70 GYR

△ - THE LONGITUDINAL JOINT SEALANT SHALL BE PLACED UNDER THE SURFACE LIFT.

- THE UNIT WEIGHT USED TO CALCULATE ALL HMA SURFACE MIXTURE QUANTITIES IS 112 LBS/SQYD/IN.

- THE "AC TYPE" FOR POLYMERIZED HMA MIXES SHALL BE "SBS/SBR PG 76 - 22" AND FOR NON-POLYMERIZED HMA THE "AC TYPE" SHALL BE "PG 64 - 22" UNLESS MODIFIED BY DISTRICT ONE SPECIAL PROVISIONS. FOR USE OF "RECYCLED MATERIAL" SEE DISTRICT ONE SPECIAL PROVISIONS.

FILE NAME =	USER NAME - USER	DESIGNED - NRH	REVISED Δ - ADDENDUM NO. 1 07/23/2018
FILE NAME =		DRAWN - NRH	REVISED
	PLOT SCALE -	CHECKED - JPT	REVISED
	PLOT DATE - 04/19/18	DATE - 04/19/18	REVISED

STATE OF ILLINOIS
 DEPARTMENT OF TRANSPORTATION

MAPLE AVENUE IMPROVEMENTS
 PROPOSED TYPICAL SECTIONS

NOT TO SCALE	SHEET NO. 1 OF 1 SHEETS	STA. TO STA.	F.A.U. RIE. 1487	SECTION 18-00113-00-RS	COUNTY DUPAGE	TOTAL SHEETS 19	SHEET NO. 5
			FED. ROAD DIST. NO. 1		ILLINOIS		CONTRACT NO. 61E92
							FED. AID PROJECT