

F.A. RTE.	SECTION	COUNTY	TOTAL SHEETS	SHEET NO.
90/94		Cook	565	201
STA.		TO STA.		
FED. ROAD DIST. NO.		ILLINOIS FED. AID PROJECT		

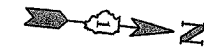
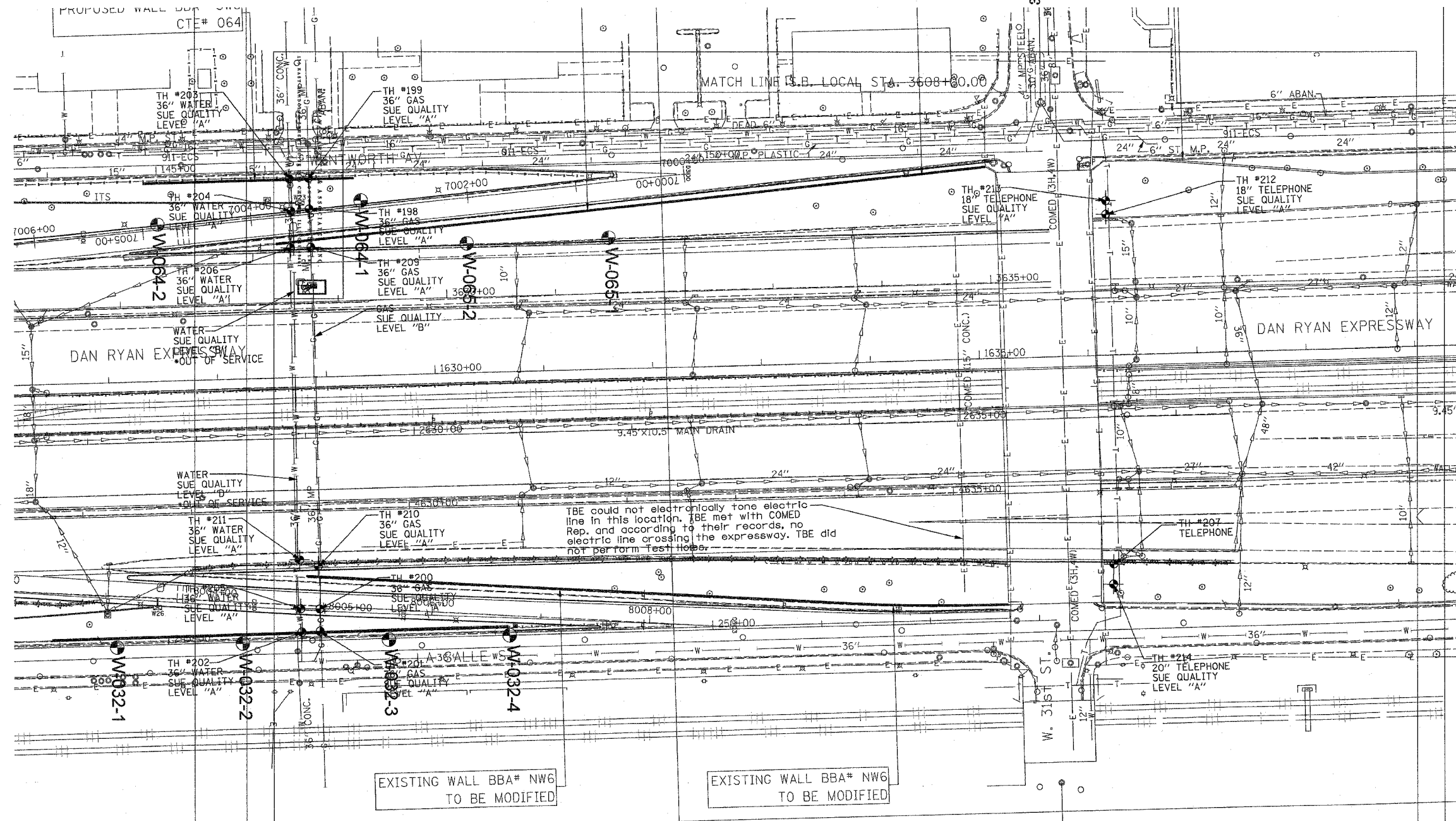

TBE GROUP, INC.
 CIVIL ENGINEERING * TRANSPORTATION * ENVIRONMENTAL
 * PLANNING * UTILITY ENGINEERING/LOCATING
 SOUTHERN REGION: FL, GA, SC, NC
 NORTHERN REGION: IL, IN, MI, OH, MD, NJ, NY
 PA, VA, CANADA
 WESTERN REGION: AZ, NV, NM, TX, CA, OR, UT, WA

IL09500164, 167, 168, 170, 171, 179, 180, 182, 204,
 205, 206, 211, 212, 219, 221, 225, 226, 227, 228, 230, 232
 TBE SUE PAGE NO: 36 of 36
 Checked by: *Sandra Z...*
 SUE Quality Level "A" : Test Holes
 SUE Quality Level "B" : Designating

—TS—	—TS—	TRAFFIC SIGNAL
—SL—	—SL—	STREET LIGHT
—COCE—		CITY OF CHICAGO ELECTRIC
—T—	—T—	TELEPHONE
—W—	—W—	WATER
—G—	—G—	GAS
—CTV—	—CTV—	CABLE TELEVISION
—FO—	—FO—	FIBER OPTIC
—E—	—E—	ELECTRIC
⊙		TEST HOLE

Utilities shown on these plans as depicted in the legend have been investigated by TBE Group, Inc in accordance with SUE Industry Standards. All other information shown has been provided to TBE Group, Inc by others.

205 W. WACKER DRIVE
 SUITE 1020
 CHICAGO, IL 60606
 (312) 704-1970

REVISIONS	
NAME	DATE

ILLINOIS DEPARTMENT OF TRANSPORTATION
 SUE Investigation of Underground Utilities
 I-90/I-94 Dan Ryan Expressway from
 I-57, to 69th Street
 Contract Number: 62590, 62592, 62594
 SOL "B" DATE : 7/22/04
 DRAWN BY : KLC
 SCALE : 1" = 50'

TBE could not locate buried utilities directly beneath the expressway due to traffic and safety issues.

*At the time of Quality Level "B" SUE services, the water lines were active. The lines, however, are now expected to be out of service per IDOT.

EXISTING WALL BBA# NW6
 TO BE MODIFIED

EXISTING WALL BBA# NW6
 TO BE MODIFIED

VERIFIED UTILITY INFORMATION

TEST HOLE #	SIZE & TYPE	NORTHING	EASTING	TOP OF UTILITY	EXISTING CUT	REFERENCE GROUND ELEVATION	COMMENTS
1	20" G	1867123.035	1175606.560	-1.85	1.50	-0.35	SUE QUALITY LEVEL "A"
2	12" W	1867115.884	1175606.924	-1.53	1.13	-0.40	SUE QUALITY LEVEL "A"
3	20" G	1867122.650	1175602.392	-0.08	0.69	0.61	SUE QUALITY LEVEL "A"
4	20" G	1867122.945	1175609.366	-6.36	5.41	-0.95	SUE QUALITY LEVEL "A"
5	20" G	1867132.835	1175901.810	-4.63	3.39	-1.24	SUE QUALITY LEVEL "A"
6	20" G	1867132.928	1175905.856	-2.34	2.74	0.40	SUE QUALITY LEVEL "A"
7	20" G	1867132.947	1175910.232	0.11	1.93	2.04	SUE QUALITY LEVEL "A"
8	20" G	1867132.990	1175897.762	-5.44	3.49	-1.95	SUE QUALITY LEVEL "A"
1A	20" G	1861211.910	1177445.200	15.85	3.65	19.50	SUE QUALITY LEVEL "A"
2A	8" W	1861211.860	1177441.360	14.70	4.87	19.57	SUE QUALITY LEVEL "A"
3A	6" G	1861211.740	1177450.260	15.19	4.18	19.37	SUE QUALITY LEVEL "A"
4A	6" G	1861598.210	1177437.850	15.50	4.43	19.93	SUE QUALITY LEVEL "A"
5A	20" G	1861598.200	1177433.420	17.22	2.82	20.04	SUE QUALITY LEVEL "A"
6A	8" W	1861597.270	1177429.100	15.66	4.42	20.08	SUE QUALITY LEVEL "A"
7A	SEE NOTE	1862113.690	1176035.420	---	7.29	0.33	SEE NOTE
8A	SEE NOTE	1862704.020	1176033.590	-6.74	5.31	-1.43	SUE QUALITY LEVEL "A"
9	16" G	1863104.250	1175969.140	-2.44	4.55	2.11	SUE QUALITY LEVEL "A"
10	16" G	1863104.500	1175976.510	-1.83	5.77	3.94	SUE QUALITY LEVEL "A"
11	16" G	1863104.750	1175982.670	0.42	5.48	5.90	SUE QUALITY LEVEL "A"
12	*42" E	1863114.170	1175968.110	-2.35	4.64	2.29	SUE QUALITY LEVEL "A"
13	*42" E	1863114.830	1175975.120	-2.35	6.43	4.08	SUE QUALITY LEVEL "A"
14	*42" E	1863116.050	1175983.240	-2.34	9.02	6.68	SUE QUALITY LEVEL "A"
14A	12" W	1863125.770	1175969.560	-2.99	5.96	2.97	SUE QUALITY LEVEL "A"
15	2x*18" BT	1863258.330	1175962.750	-6.25	9.98	3.73	SUE QUALITY LEVEL "A"
16	2X*18" BT	1863256.850	1175970.740	-3.14	9.44	6.30	SUE QUALITY LEVEL "A"
17	2x*18" BT	1863255.680	1175981.210	-3.00	12.97	9.97	SUE QUALITY LEVEL "A"
18	2x*18" BT	1863254.030	1175661.690	-5.00	8.95	3.95	SUE QUALITY LEVEL "A"
19	2x*18" BT	1863252.560	1175654.200	-4.38	11.01	6.63	SUE QUALITY LEVEL "A"
20	2x*18" BT	1863250.510	1175644.060	-3.62	13.39	9.77	SUE QUALITY LEVEL "A"
21	*42" E	1863105.180	1175669.260	0.89	3.54	4.43	SUE QUALITY LEVEL "A"
22	*42" E	1863105.160	1175660.820	-1.00	7.50	6.50	SUE QUALITY LEVEL "A"

VERIFIED UTILITY INFORMATION

TEST HOLE #	SIZE & TYPE	NORTHING	EASTING	TOP OF UTILITY	EXISTING CUT	REFERENCE GROUND ELEVATION	COMMENTS
23	*42" E	1863105.310	1175651.280	-0.63'	10.05'	9.42'	SUE QUALITY LEVEL "A"
24	16" G	1863097.580	1175669.900	0.15'	4.36'	4.51'	SUE QUALITY LEVEL "A"
25	16" G	1863097.130	1175661.950	1.09'	5.01'	6.10'	SUE QUALITY LEVEL "A"
26	16" G	1863096.690	1175655.260	1.53'	6.63'	8.16'	SUE QUALITY LEVEL "A"
27	*18" BT	1865094.940	1175582.150	0.35'	11.57'	11.92'	SUE QUALITY LEVEL "A"
28	*18" BT	1865097.810	1175578.180	1.03'	12.10'	13.13'	SUE QUALITY LEVEL "A"
29	*18" BT	1865100.160	1175573.950	2.11'	12.95'	14.46'	SUE QUALITY LEVEL "A"
30	*36" E	1865099.910	1175578.500	-3.55'	16.71'	13.16'	SUE QUALITY LEVEL "A"
31	*36" E	1865103.162	1175573.669	-2.89'	17.47'	14.58'	SUE QUALITY LEVEL "A"
32	*36" E	1865097.615	1175581.930	-3.91'	15.88'	11.97'	SUE QUALITY LEVEL "A"
33	*36" E	1865124.435	1175973.073	0.82'	13.43'	14.25'	SUE QUALITY LEVEL "A"
34	*18" BT	1865090.975	1175932.544	-4.41'	6.37'	1.96'	SUE QUALITY LEVEL "A"
35	*36" E	1865105.924	1175934.833	-4.59'	7.05'	2.46'	SUE QUALITY LEVEL "A"
36	*36" E	1865120.467	1175968.691	-0.94'	14.14'	13.20'	SUE QUALITY LEVEL "A"
37	*18" BT	1865098.448	1175972.477	2.26'	10.37'	12.63'	SUE QUALITY LEVEL "A"
38	*18" BT	1865095.321	1175968.307	-0.23'	12.22'	11.99'	SUE QUALITY LEVEL "A"
39	See Note G	1873623.853	1175722.432	---	16.00'	12.60'	CLEARANCE DEPTH
40	20" G	1873624.086	1175713.696	-6.36'	16.78'	10.42'	SUE QUALITY LEVEL "A"
41	20" G	1873629.270	1175680.376	-10.19'	9.14'	-1.05'	SUE QUALITY LEVEL "A"
42	20" G	1873630.734	1175671.020	-12.73'	9.01'	-3.72'	SUE QUALITY LEVEL "A"
43	20" G	1873631.833	1175664.164	-13.65'	7.75'	-5.90'	SUE QUALITY LEVEL "A"
44	20" G	1873662.688	1175369.141	-3.90'	4.72'	0.82'	SUE QUALITY LEVEL "A"
45	20" G	1873663.608	1175361.458	-2.90'	5.76'	2.86'	SUE QUALITY LEVEL "A"
46	20" G	1873664.488	1175351.804	-0.50'	5.98'	5.48'	SUE QUALITY LEVEL "A"
47	20" G	1873661.260	1175377.470	-4.21'	3.61'	-0.60'	SUE QUALITY LEVEL "A"
48	*36" E	1865096.950	1175617.420	-3.95'	5.91'	1.96'	SUE QUALITY LEVEL "A"
48A	(3)12" UNK	1865098.890	1175616.560	-1.25'	3.20'	1.95'	
49	20" G	1873654.520	1175434.880	-6.86'	4.54'	-2.32'	SUE QUALITY LEVEL "A"
50	*36" E	1865097.950	1175663.360	-4.48'	6.85'	2.37'	SUE QUALITY LEVEL "A"
51	*18" BT	1865085.150	1175663.290	-5.46'	7.73'	2.27'	SUE QUALITY LEVEL "A"
52	*18" BT	1865085.030	1175617.240	-4.60'	6.57'	1.97'	SUE QUALITY LEVEL "A"

TBE Project Information

* Size given is duct width only.
 TH#7A unable to determine object found due to water & soil collapsing.
 TH#8A found old wood RR ties laid straight in direction of duct. Could not expose utility, however, SBC confirmed that the duct is directly below RR ties. The existing cut is to top of RR ties.
 TH#39 TBE could not physically see gas main. Dug to 16' got electronic depth of 19.5'.

ALL INFORMATION SHOWN WAS OBTAINED FROM A LOCATION SURVEY.

Illinois Department of Transportation
 I-90 /94 (NB & SB of Dan Ryan Expressway)
 Chicago-Cook County
 Sec No: (2122-921 PT1) R, (2021-922 PT1,2)
 Contract No. 62586, 62589, 62693, 62694, 62695
 TBE Project No.: IL09500164, 167, 168, 170, 171, 179, 180, 182, 204, 205, 206, 211, 212, 219, 221, 225, 226, 227, 228, 230, 232

R E V I S I O N S											
DATE	BY	DESCRIPTION	DATE	BY	DESCRIPTION	DATE	BY	DESCRIPTION	DATE	BY	DESCRIPTION
6-15-05	KLC	REMOVE QL "A" FROM TH#8A									

 TBE GROUP, INC. <small>SOUTHERN REGION: FL, GA, SC, NC NORTHERN REGION: IL, IN, MI, OH, MO, NJ, NY PA, VA, CANADA WESTERN REGION: AZ, NV, NM, TX, CA, OR, UT, WA</small>	VERIFIED UTILITY LOCATIONS
---	-----------------------------------

Handwritten: M. Adams E-9802

VERIFIED UTILITY INFORMATION

TEST HOLE #	SIZE & TYPE	NORTHING	EASTING	TOP OF UTILITY	EXISTING CUT	REFERENCE GROUND ELEVATION	COMMENTS
53	*18" BT	1865113.010	1175555.020	4.67'	14.33'	19.00'	SUE QUALITY LEVEL "A"
54	See Note E	1865117.050	1175555.790	---	18.59'	18.99'	CLEARANCE DEPTH ONLY
55	*18" BT	1865108.400	1175989.320	9.85'	9.02'	18.87'	SUE QUALITY LEVEL "A"
55A	24" SAN	1865109.300	1175987.610	11.77'	7.10'	18.87'	SUE QUALITY LEVEL "A"
56	*36" E	1865136.380	1175984.770	3.20'	15.68'	18.88'	SUE QUALITY LEVEL "A"
56A	24" SAN	1865138.320	1175986.600	11.93'	6.92'	18.85'	SUE QUALITY LEVEL "A"
57	*18" BT	1865091.120	1175928.050	-5.77'	7.13'	1.36'	SUE QUALITY LEVEL "A"
58	*36" E	1865105.640	1175928.120	-4.59'	6.03'	1.44'	SUE QUALITY LEVEL "A"
59	*36" E	1865104.390	1175856.480	-4.90'	7.41'	2.51'	SUE QUALITY LEVEL "A"
60	*18" BT	1865090.480	1175856.950	-5.29'	7.65'	2.36'	SUE QUALITY LEVEL "A"

MAN HOLE #	TYPE	NORTHING	EASTING	TOP OF UTILITY	EXISTING CUT	REFERENCE MH RIM ELEVATION	COMMENTS
61	Telephone	1863240.510	1175610.790	*1.41'	19.13'	20.54'	SUE QUALITY LEVEL "A"

TEST HOLE #	SIZE & TYPE	NORTHING	EASTING	TOP OF UTILITY	EXISTING CUT	REFERENCE GROUND ELEVATION	COMMENTS
62	*48" E	1876425.900	1176044.730	-6.88'	3.44'	-3.44'	SUE QUALITY LEVEL "A"
63	*48" E	1876427.860	1176056.140	-4.87'	4.14'	-0.73'	SUE QUALITY LEVEL "A"
64	*48" E	1876443.770	1176104.400	4.13'	8.39'	12.52'	SUE QUALITY LEVEL "A"
65	*48" E	1863237.110	1175774.930	-1.66'	4.62'	2.96'	SUE QUALITY LEVEL "A"
66	*48" E	1841495.350	1177598.790	8.42'	7.24'	15.66'	SUE QUALITY LEVEL "A"
67	*48" E	1852792.550	1177384.230	-10.35'	4.37'	-5.98'	SUE QUALITY LEVEL "A"
68	*48" E	1852792.730	1177375.900	-8.91'	4.03'	-4.88'	SUE QUALITY LEVEL "A"
69	*48" E	1841506.530	1177600.310	7.60'	8.15'	15.75'	SUE QUALITY LEVEL "A"
70	*48" E	1852792.330	1177435.710	-12.58'	5.65'	-6.93'	SUE QUALITY LEVEL "A"
71	*28" E	1841906.380	1177641.010	12.54'	3.46'	16.00'	SUE QUALITY LEVEL "A"
72	*48" E	1852791.510	1177336.410	1.83'	7.76'	9.59'	SUE QUALITY LEVEL "A"
73	*48" E	1876423.560	1175920.080	-12.48'	8.82'	-3.66'	SUE QUALITY LEVEL "A"
74	*48" E	1863227.820	1175613.390	8.97'	11.23'	20.20'	SUE QUALITY LEVEL "A"
75	*48" E	1841508.250	1177677.360	-7.19'	4.61'	-2.58'	SUE QUALITY LEVEL "A"
76	*48" E	1841498.000	1177684.360	-7.65'	4.53'	-3.12'	SUE QUALITY LEVEL "A"
77	*48" E	1841492.150	1177692.100	-7.95'	7.02'	-0.93'	SUE QUALITY LEVEL "A"

TBE Project Information

* Size given is duct width only.
 TH#54 TBE could not reach utility due to depth, Clearance given.
 MH#61 Man Hole elevation to top of phone cables exiting man hole.
 TH#80 Could not expose utilities due to extremely hard clay. Clearance depth of 7.88' given.
 TH#81 Appears to be a 34" poured in place concrete cap over CTA conduit.
 TH#87 found a 16" pipe but was unable to see it due to water table. Probed another 3' down past pipe, unable to find 36" w/m electronic Depth 24'
 TH#89 Utility not exposed due to excessive water in hole.
 TH#90 Utility not exposed, clearance depth of 13.65'.
 TH#96 Utility not exposed, clearance depth of 10.80'.
 TH#97 Reference point destroyed by construction crews before survey could be completed. Material was unidentifiable.
 TH#104 Concrete cap poured over utility.
 TH#107 Utility not exposed, clearance depth of 16.79'.

ALL INFORMATION SHOWN WAS OBTAINED FROM A LOCATION SURVEY.

VERIFIED UTILITY INFORMATION

TEST HOLE #	SIZE & TYPE	NORTHING	EASTING	TOP OF UTILITY	EXISTING CUT	REFERENCE GROUND ELEVATION	COMMENTS
78	*48" E	1841506.430	1177692.980	-8.94'	7.98'	-0.96'	SUE QUALITY LEVEL "A"
79	*48" E	1841510.920	1177755.020	-9.22'	10.16'	0.94'	SUE QUALITY LEVEL "A"
80	SEE NOTE E	1841493.150	1177753.350	---	7.88'	1.00'	CLEARANCE DEPTH ONLY
81	SEE NOTE E	1852793.298	1177394.984	-11.95'	4.69'	-7.26'	SUE QUALITY LEVEL "A"
82	*48" E	1863234.932	1175653.520	-0.86'	7.66'	6.80'	SUE QUALITY LEVEL "A"
83	*48" E	1863235.070	1175661.514	-1.64'	5.94'	4.31'	SUE QUALITY LEVEL "A"
84	36" W	1839944.740	1178217.900	-5.13'	2.96'	-2.17'	SUE QUALITY LEVEL "A"
85	36" W	1839889.120	1178193.100	-13.96'	8.61'	-5.35'	SUE QUALITY LEVEL "A"
86	36" W	1839415.910	1178025.040	-1.59'	3.05'	1.46'	SUE QUALITY LEVEL "A"
87	16" UNK	1839528.800	1178066.220	-3.15'	10.03'	6.88'	
88	24" TEL	1839826.880	1178316.500	-6.59'	7.19'	0.60'	SUE QUALITY LEVEL "A"
89	SEE NOTE TEL	1839836.600	1178319.800	-5.49'	5.98'	0.49'	
90	SEE NOTE TEL	1839793.600	1178305.180	---	13.65'	0.40'	CLEARANCE DEPTH ONLY
91	24" TEL	1844059.140	1177578.380	13.58'	2.89'	16.47'	SUE QUALITY LEVEL "A"
92	36" W	1839745.710	1178145.690	-18.57'	9.32'	-9.25'	SUE QUALITY LEVEL "A"
93	24" BT	1844060.690	1177635.830	-6.44'	7.25'	0.81'	SUE QUALITY LEVEL "A"
94	24" BT	1844060.680	1177625.600	-3.42'	6.54'	3.12'	SUE QUALITY LEVEL "A"
95	16" W	1839246.750	1178863.580	-6.12'	3.82'	-2.30'	SUE QUALITY LEVEL "A"
96	SEE NOTE W	1838928.400	1178898.950	---	10.80'	-1.89'	CLEARANCE DEPTH ONLY
97	18" BT				6.12'		NOT SURVEYED
98	20" BT	1841825.960	1177936.970	6.82'	8.10'	14.92'	SUE QUALITY LEVEL "A"
99	36" W	1874261.670	1175871.220	-1.10'	3.83'	2.73'	SUE QUALITY LEVEL "A"
100	36" W	1874261.650	1175880.560	1.35'	3.90'	5.25'	SUE QUALITY LEVEL "A"
101	36" W	1874245.970	1175540.410	-2.86'	4.69'	1.83'	SUE QUALITY LEVEL "A"
102	36" W	1874245.820	1175531.730	-0.50'	4.56'	4.06'	SUE QUALITY LEVEL "A"
103	36" W	1874244.500	1175483.430	11.43'	4.34'	15.77'	SUE QUALITY LEVEL "A"
104	SEE NOTE W	1874262.410	1175925.500	13.62'	3.18'	16.80'	SUE QUALITY LEVEL "A"
105	36" W	1874245.260	1175675.910	-2.22'	2.72'	0.50'	SUE QUALITY LEVEL "A"
106	18" BT	1847350.430	1177491.230	-0.33'	8.75'	8.42'	SUE QUALITY LEVEL "A"
107	SEE NOTE BT	1847365.000	1177775.620	---	16.79'	7.85'	CLEARANCE DEPTH ONLY
108	24" BT	1844064.680	1177880.760	6.97'	9.52'	16.49'	SUE QUALITY LEVEL "A"
109	36" W	1874248.230	1175729.730	-1.93'	3.19'	1.26'	SUE QUALITY LEVEL "A"

Illinois Department of Transportation

I-90 /94 (NB & SB of Dan Ryan Expressway)
 Chicago-Cook County
 Sec No: (2122-921 PT1) R, (2021-922 PT1,2)
 Contract No. 62586, 62589, 62693, 62694, 62695
 TBE Project No.: IL09500164, 167, 168, 170, 171, 179, 180, 182, 204, 205, 206, 211, 212, 219, 221, 225, 226, 227, 228, 230, 232

REVISIONS											
DATE	BY	DESCRIPTION	DATE	BY	DESCRIPTION	DATE	BY	DESCRIPTION	DATE	BY	DESCRIPTION
6-15-06	KLC	REMOVE QL "A" FROM TH#7 & 89									

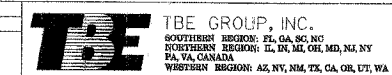

VERIFIED UTILITY LOCATIONS

J. Johnson E-9802

VERIFIED UTILITY INFORMATION

TEST HOLE #	SIZE & TYPE	NORTHING	EASTING	TOP OF UTILITY	EXISTING CUT	REFERENCE GROUND ELEVATION	COMMENTS
110	24" BT	1841825.430	1177895.600	-4.15'	4.72'	0.57'	SUE QUALITY LEVEL "A"
111	24" BT	1841825.960	1177908.730	1.05'	4.44'	5.49'	SUE QUALITY LEVEL "A"
112	SEE NOTE BT	1844068.060	1177841.750	---	6.79'	2.89'	CLEARANCE DEPTH ONLY
113	SEE NOTE BT	1844066.820	1177850.390	---	8.03'	5.96'	CLEARANCE DEPTH ONLY
114	24" BT	1847363.280	1177733.270	-13.55'	5.33'	-8.22'	SUE QUALITY LEVEL "A"
115	24" BT	1847363.890	1177740.570	-12.87'	7.00'	-5.87'	SUE QUALITY LEVEL "A"
116	24" BT	1847364.010	1177750.010	-13.15'	10.51'	-2.64'	SUE QUALITY LEVEL "A"
117	24" BT	1847354.070	1177540.800	-12.62'	4.98'	-7.64'	SUE QUALITY LEVEL "A"
118	24" BT	1847354.020	1177532.210	-11.52'	4.52'	-7.00'	SUE QUALITY LEVEL "A"
119	24" BT	1841818.360	1177704.030	-6.42'	4.55'	-1.87'	SUE QUALITY LEVEL "A"
120	24" BT	1841818.190	1177694.600	-5.43'	5.12'	-0.31'	SUE QUALITY LEVEL "A"
121	24" E	1844061.030	1177617.950	-1.50'	6.67'	5.17'	SUE QUALITY LEVEL "A"
122	(3) 1" E	1840742.250	1177446.860	10.93'	4.47'	15.40'	SUE QUALITY LEVEL "A"
123	(2) 2.5" E	1840753.910	1177452.070	12.73'	2.88'	15.61'	SUE QUALITY LEVEL "A"
124	2" BT	1840831.420	1177479.340	13.17'	2.57'	15.74'	SUE QUALITY LEVEL "A"
125	2" E	1840820.710	1177506.720	5.90'	3.01'	8.91'	SUE QUALITY LEVEL "A"
126	2" E	1840804.920	1177597.800	0.06'	3.54'	3.60'	SUE QUALITY LEVEL "A"
127	(3) 1" E	1840788.150	1177688.790	0.28'	3.56'	3.84'	SUE QUALITY LEVEL "A"
128	2" E	1840818.210	1177530.500	0.02'	1.85'	1.87'	SUE QUALITY LEVEL "A"
129	2" E	1840816.460	1177545.960	0.42'	1.74'	2.16'	SUE QUALITY LEVEL "A"
130	SEE NOTE BT	1839700.920	1178266.540	---	10.98'	-7.69'	CLEARANCE DEPTH ONLY
131	SEE NOTE BT	1839752.990	1178287.460	---	11.56'	-8.92'	CLEARANCE DEPTH ONLY
132	18" G	1852714.050	1177342.550	0.87'	7.94'	8.81'	SUE QUALITY LEVEL "A"
133	18" G	1852719.380	1177340.460	1.09'	8.36'	9.45'	SUE QUALITY LEVEL "A"
134	8" G	1847348.900	1177540.960	-13.64'	6.05'	-7.59'	SUE QUALITY LEVEL "A"
135	8" G	1847348.540	1177532.100	-11.04'	4.42'	-6.62'	SUE QUALITY LEVEL "A"
136	8" G	1847347.120	1177490.770	1.16'	7.28'	8.44'	SUE QUALITY LEVEL "A"
137	18" G	1852715.850	1177387.130	-13.52'	7.22'	-6.30'	SUE QUALITY LEVEL "A"
138	18" G	1852720.360	1177378.410	-11.64'	7.05'	-4.59'	SUE QUALITY LEVEL "A"
139	18" G	1852715.890	1177378.870	-10.80'	6.30'	-4.50'	SUE QUALITY LEVEL "A"
140	18" G	1852720.130	1177387.470	-13.53'	7.46'	-6.07'	SUE QUALITY LEVEL "A"

VERIFIED UTILITY INFORMATION

TEST HOLE #	SIZE & TYPE	NORTHING	EASTING	TOP OF UTILITY	EXISTING CUT	REFERENCE GROUND ELEVATION	COMMENTS
141	8" G	1847360.470	1177779.600	3.77'	4.76'	8.53'	SUE QUALITY LEVEL "A"
142	18" G	1852731.450	1177624.740	-0.09'	9.49'	9.40'	SUE QUALITY LEVEL "A"
143	18" G	1852724.450	1177627.310	-1.19'	10.92'	9.73'	SUE QUALITY LEVEL "A"
144	34" BT	1853977.420	1177596.570	1.18'	8.13'	9.31'	SUE QUALITY LEVEL "A"
145	18" G	1852725.400	1177579.740	-14.03'	6.32'	-7.71'	SUE QUALITY LEVEL "A"
146	18" G	1852729.670	1177579.630	-14.36'	6.93'	-7.43'	SUE QUALITY LEVEL "A"
147	18" G	1852729.620	1177588.130	-12.06'	7.15'	-4.91'	SUE QUALITY LEVEL "A"
148	18" G	1852725.710	1177589.950	-11.85'	7.38'	-4.47'	SUE QUALITY LEVEL "A"
149	8" G	1847359.120	1177733.980	-13.27'	4.96'	-8.31'	SUE QUALITY LEVEL "A"
150	8" G	1847359.090	1177742.040	-10.62'	5.02'	-5.60'	SUE QUALITY LEVEL "A"
151	34" BT	1853976.090	1177565.940	-2.85'	4.64'	1.79'	SUE QUALITY LEVEL "A"
152	34" BT	1853965.300	1177212.750	1.75'	6.56'	8.31'	SUE QUALITY LEVEL "A"
153	34" BT	1853967.560	1177268.590	-5.31'	4.54'	-0.77'	SUE QUALITY LEVEL "A"
154	34" BT	1853974.820	1177507.770	-7.53'	5.75'	-1.78'	SUE QUALITY LEVEL "A"
155	34" BT	1853976.540	1177529.050	-4.24'	5.72'	1.48'	SUE QUALITY LEVEL "A"
156	34" BT	1853967.230	1177304.800	-5.16'	4.11'	-1.05'	SUE QUALITY LEVEL "A"
157	30" G	1839844.630	1178297.170	-11.94'	11.58'	-0.36'	SUE QUALITY LEVEL "A"
158	30" G	1839771.030	1178274.550	-15.29'	6.58'	-8.71'	SUE QUALITY LEVEL "A"
159	30" G	1839779.300	1178277.090	-15.12'	6.55'	-8.57'	SUE QUALITY LEVEL "A"
160	N/A G	1839815.630	1178285.320	---	7.00'	-7.56'	CLEARANCE ONLY
161	30" G	1839683.380	1178240.910	-8.79'	10.86'	-19.65'	SUE QUALITY LEVEL "A"
162	N/A G	1839720.200	1178252.850	---	7.00'	-14.44'	CLEARANCE ONLY
163	30" G	1839633.400	1178223.490	-10.63'	6.14'	-16.77'	SUE QUALITY LEVEL "A"
164	30" G	1839624.490	1178220.270	-10.23'	6.61'	-16.84'	SUE QUALITY LEVEL "A"

TBE Project Information

TH#112 Utility not exposed, clearance depth of 6.79'.
 TH#113 Utility not exposed, clearance depth of 8.03'.
 TH#130 Utility not exposed, clearance depth of 10.98'.
 TH#131 Utility not exposed, clearance depth of 11.56'.
 TH#136 Unable to expose utility due to hard clay, probed and felt top and side of utility.
 TH#145 & 146 Unable to expose utility due to water table at 3' +/-, but were able to feel the sides and top.
 TH#160 & 162 Unable to expose utility due to hard clay, clearance of 7' given.
 TH#161 Unable to expose utility due to water, but did feel the pipe.
 TH#163 & 164 Unable to expose utility due to water, but did feel top and sides of 30" pipe.

ALL INFORMATION SHOWN WAS OBTAINED FROM A LOCATION SURVEY.

Illinois Department of Transportation

I-90 /94 (NB & SB of Dan Ryan Expressway)
 Chicago-Cook County
 Sec No: (2122-921 PT1) R, (2021-922 PT1,2)
 Contract No. 62586, 62589, 62693, 62694, 62695
 TBE Project No.: IL09500164, 167, 168, 170, 171, 179, 180, 182, 204, 205, 206, 211, 212, 219, 221, 225, 226, 227, 228, 230, 232

REVISIONS											
DATE	BY	DESCRIPTION	DATE	BY	DESCRIPTION	DATE	BY	DESCRIPTION	DATE	BY	DESCRIPTION
6-15-05	KLC	REMOVE CL "A" FROM TH#136, 146, 146, 161, 163 & 164. REMOVED TOP OF UTILITY FROM TH#160 & 162									

JH 6-15-05

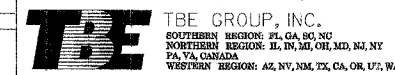

VERIFIED UTILITY LOCATIONS

VERIFIED UTILITY INFORMATION

TEST HOLE #	SIZE & TYPE	NORTHING	EASTING	OFFSET	TOP OF UTILITY	EXISTING CUT	REFERENCE GROUND ELEVATION	COMMENTS
165	24" G	1858583.099	1177452.100	148.05 RT	-2.91'	6.08'	3.18'	SUE QUALITY LEVEL "A"
166	24" G	1858582.607	1177422.881	118.82 RT	-7.96'	11.04'	3.08'	SUE QUALITY LEVEL "A"
167	24" G	1858581.829	1177388.290	84.23 RT	-11.42'	5.64'	-5.78'	SUE QUALITY LEVEL "A"
168	— G	1858576.435	1177169.958	73.59 LT	-14.41'	7.92'	-6.49'	SEE NOTE
169A	— G	1858575.515	1177148.755	94.81 LT	-8.73'	5.63'	-3.10'	SEE NOTE
169B	8" —	1858574.341	1177148.755	94.81 LT	-7.34'	4.24'	-3.10'	SUE QUALITY LEVEL "A"
170	24" G	1858574.341	1177125.527	118.07 LT	1.84'	4.35'	6.19'	SUE QUALITY LEVEL "A"
171	24" G	1858573.831	1177107.217	136.38 LT	5.50'	5.82'	11.32'	SUE QUALITY LEVEL "A"
172	36" E	1859349.450	1177086.590	133.62 LT	-2.77'	10.34'	7.57'	SUE QUALITY LEVEL "A"
173	36" E	1859349.210	1177115.830	104.39 LT	-5.89'	4.92'	-0.97'	SUE QUALITY LEVEL "A"
174	— BT	1859189.980	1177120.790	104.24 LT	-13.77'	12.58'	-1.19'	SUE QUALITY LEVEL "A"
175	— BT	1859187.890	1177093.060	132.02 LT	SEE NOTE	9.12'	4.53'	CLEARANCE ONLY
176	36" E	1859357.690	1177382.160	100.06 RT	-11.29'	4.45'	-6.84'	SUE QUALITY LEVEL "A"
177	— E	1859358.400	1177405.990	123.90 RT	-10.32'	10.06'	-0.26'	SUE QUALITY LEVEL "A"
178	— T	1859198.040	1177390.570	103.95 RT	-21.35'	12.85'	-8.50'	SUE QUALITY LEVEL "A"
179	— E	1859345.500	1177059.620	160.69 LT	SEE NOTE	15.15'	16.93'	CLEARANCE ONLY
180	36" G	1851291.10	1177413.23	80.62 LT	-9.95'	6.63'	-3.32'	SUE QUALITY LEVEL "A"
181	36" G	1851290.85	1177418.67	75.19 LT	-9.70'	6.38'	-3.32'	SUE QUALITY LEVEL "A"
182	36" G	1851297.11	1177630.28	136.52 RT	-8.88'	5.89'	-2.94'	SUE QUALITY LEVEL "A"
MAN HOLE #								
183	24" G	1851285.94	1177708.75	45.04 RT	4.76'	4.16'	8.92'	Elev. taken from RIM of MH.
184	12" G	1851278.82	1177708.69	44.77 RT	4.39'	4.52'	8.91'	Elev. taken from RIM of MH.
TEST HOLE #	SIZE & TYPE	NORTHING	EASTING	OFFSET	TOP OF UTILITY	EXISTING CUT	REFERENCE GROUND ELEVATION	COMMENTS
185	72" BT	1877424.23	1176032.38	61.60 LT	-3.79'	2.70'	-1.09'	SUE QUALITY LEVEL "A"
186	66" BT	1877416.11	1175712.30	66.43 RT	-8.51'	5.85'	-2.66'	SEE NOTE

NOTES

TH #168 Unable to see gas due to ground water.
 TH #169A Unable to see gas due to back fill continually caving in.
 TH #174 We were unable to determine size due to ground water in the hole.
 TH #175 Attempt was made to expose phone duct but were unsuccessful due to extreme heavy compacted clay, we were only able to reach 9.12'
 TH #179 Attempt was made to find electric duct. Went down 15.15' & 2.5' radius of Reference Point.
 TH #186 Unable to expose due to mud and ground water, felt top and sides.
 TH #187 Unable to expose due to wet sand collapsing in hole.
 TH #189 - Offset is taken from N. bound Dan Ryan fence line.
 TH #190 - Unable to expose due to soil collapsing in hole
 TH #192 - Telephone was buried/trenched underneath a slab of concrete with rough edges; width was 48"
 TH #195 - Unable to expose due to deep roots in hole
 TH #200 - Felt both sides of gas line but unable to cover completely for picture, doing so would leave a void in soil because of angle of ground level. Back fill kept falling from uphill.
 TH #204 - Found the utilities for the street lights at about 2' deep. Offset pulled from CL of Dan Ryan on ramp.
 TH #207 - Could not expose due to collapsing sand. Had a good feel with the air lance. Offset taken from CL of exit ramp
 TH #215A - TBE could not find electric crossing, vacumed down 13'.

VERIFIED UTILITY INFORMATION

TEST HOLE #	SIZE & TYPE	NORTHING	EASTING	OFFSET	TOP OF UTILITY	EXISTING CUT	REFERENCE GROUND ELEVATION	COMMENTS
187	— W	1880442.920	1175949.580	65.37' RT	3.59'	8.43'	12.02'	SEE NOTE
188	16" BT	1880464.590	1175947.690	64.06' RT	6.63'	5.31'	11.94'	SUE QUALITY LEVEL "A"
189	24" W	1880443.800	1175999.780	115.57' RT	7.85'	7.83'	15.68'	SUE QUALITY LEVEL "A"
190	— W	1880442.870	1175973.130	88.91' RT	3.81'	10.10'	13.91'	SEE NOTE
191	16" BT	1880465.830	1175973.580	89.98' RT	9.59'	4.42'	14.01'	SUE QUALITY LEVEL "A"
192	16" BT	1880464.890	1175999.080	115.44' RT	10.21'	5.35'	15.56'	SUE QUALITY LEVEL "A"
193	16" BT	1880456.000	1175630.210	61.54' LT	5.65'	8.94'	11.59'	SUE QUALITY LEVEL "A"
194	16" BT	1880454.690	1175603.520	88.25' LT	5.44'	8.66'	14.10'	SUE QUALITY LEVEL "A"
195	— BT	1880453.540	1175575.610	116.18' LT	4.75'	12.13'	16.88'	SEE NOTE
196	24" W	1880435.180	1175604.240	88.06' LT	6.76'	7.24'	14.00'	SUE QUALITY LEVEL "A"
197	24" W	1880435.160	1175579.320	112.97' LT	11.06'	5.48'	16.54'	SUE QUALITY LEVEL "A"
198	36" G	1883748.370	1175516.740	86.01' LT	1.10'	7.08'	8.18'	SUE QUALITY LEVEL "A"
199	36" G	1883747.800	1175488.980	113.78' LT	6.36'	8.62'	14.98'	SUE QUALITY LEVEL "A"
200	36" G	1883758.000	1175883.780	89.15' RT	-1.07'	5.96'	4.89'	SUE QUALITY LEVEL "A"
201	36" G	1883758.190	1175903.970	109.34' RT	4.06'	6.58'	10.64'	SUE QUALITY LEVEL "A"
202	36" W	1883741.550	1175904.750	109.67' RT	4.82'	5.74'	10.56'	SUE QUALITY LEVEL "A"
203	36" W	1883730.260	1175489.640	113.59' LT	8.72'	6.25'	14.97'	SUE QUALITY LEVEL "A"
204	36" W	1883731.680	1175518.680	84.53' LT	1.69'	5.90'	7.59'	SUE QUALITY LEVEL "A"
205	36" W	1883740.460	1175883.620	88.52' RT	-3.96'	8.26'	4.30'	SUE QUALITY LEVEL "A"
206	36" W	1883731.390	1175553.040	50.19' LT	-5.51'	6.13'	0.62'	SUE QUALITY LEVEL "A"
207	— BT	1884487.410	1175842.900	67.99' RT	-6.61'	2.98'	-3.63'	SEE NOTE
208	24" W	1880435.060	1175628.960	63.35' LT	3.08'	8.72'	11.80'	SUE QUALITY LEVEL "A"
209	36" G	1883749.960	1175552.500	50.22' LT	-5.24'	5.99'	0.75'	SUE QUALITY LEVEL "A"
210	36" G	1883756.720	1175845.280	50.63' RT	-6.85'	8.42'	1.566'	SUE QUALITY LEVEL "A"
211	36" W	1883739.550	1175839.290	44.18' RT	-5.25'	5.86'	0.606'	SUE QUALITY LEVEL "A"
212	18" BT	1884480.420	1175521.840	61.14' LT	-7.58'	4.95'	-2.634'	SUE QUALITY LEVEL "A"
213	18" BT	1884480.320	1175509.110	73.87' LT	-3.89'	4.91'	1.019'	SUE QUALITY LEVEL "A"
214	20" BT	1884487.060	1175860.740	85.82' RT	-0.82'	3.19'	2.370'	SUE QUALITY LEVEL "A"
215	(12" (3).25" SL	1879776.080	1175973.630	71.39' RT	2.91'	4.08'	6.995'	SUE QUALITY LEVEL "A"
215A	SEE NOTE	1879798.750	1175970.990	69.36' RT	SEE NOTE	13.00'	7.040'	SEE NOTE

ALL INFORMATION SHOWN WAS OBTAINED FROM A LOCATION SURVEY.

Illinois Department of Transportation

I-90 /94 (NB & SB of Dan Ryan Expressway)
 Chicago-Cook County
 Sec No: (2122-921 PT1) R, (2021-922 PT1,2)
 Contract No. 62584, 62585, 62586, 62589, 62693, 62694, 62695
 TBE Project No.: IL09500164, 167, 168, 170, 171, 179, 180, 182, 204, 205, 206, 211, 212, 219, 221, 225, 226, 227, 228, 230, 232, 238

DATE	BY	DESCRIPTION	DATE	BY	DESCRIPTION	DATE	BY	DESCRIPTION	DATE	BY	DESCRIPTION	DATE	BY	DESCRIPTION
5/19/05	SXT	SAFAC												

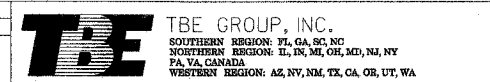

VERIFIED UTILITY LOCATIONS

VERIFIED UTILITY INFORMATION

TEST HOLE #	SIZE & TYPE	NORTHING	EASTING	OFFSET	TOP OF UTILITY	EXISTING CUT	REFERENCE GROUND ELEVATION	COMMENTS
230	— E	1839771.480	1178282.900	40.98 RT	-14.59'	5.95'	-8.64'	SEE NOTE
231	— E	1839717.190	1178262.450	7.63 LT	-16.67'	9.39'	-7.28'	SEE NOTE
232	24" BT	1847362.650	1177722.670	54.90 RT	-13.90'	4.58'	-9.32'	SUE QUALITY LEVEL "A"
233	— BT	1847364.070	1177666.640	1.06 LT	-15.30'	6.00'	-9.30'	SEE NOTE
233A	— BT	1847359.460	1177663.330	4.50 LT	-14.90'	5.50'	-9.40'	SEE NOTE
234	24" BT	1847358.540	1177612.300	5.81 RT	-17.19'	7.70'	-9.49'	SEE NOTE
235	24" BT	1847354.940	1177556.570	50.00 LT	-14.25'	4.98'	-9.27'	SEE NOTE
236	50" G	1842060.050	1177876.280	56.67 RT	-11.10'	8.03'	-3.07'	SUE QUALITY LEVEL "A"
237	16" G	1842055.250	1177879.140	59.39 RT	-11.77'	8.63'	-3.14'	SUE QUALITY LEVEL "A"
238	16" G	1842053.000	1177820.220	0.43 RT	-10.82'	8.18'	-2.64'	SEE NOTE
239	50" G	1842057.820	1177814.630	5.02 LT	-10.68'	7.74'	-2.94'	SEE NOTE
240	16" G	1842048.430	1177699.910	58.61 LT	-11.07'	7.86'	-3.21'	SEE NOTE
241	50" G	1842054.250	1177699.450	58.90 LT	-10.21'	6.91'	-3.30'	SUE QUALITY LEVEL "A"
242	50" G	1842060.221	1177881.622	62.02 RT	-11.18'	7.90'	-3.28'	SUE QUALITY LEVEL "A"
243	36" BT	1855343.345	1177259.048	62.73 LT	-15.28'	6.93'	-8.35'	SUE QUALITY LEVEL "A"
244	— BT	1855347.498	1177446.026	63.35 RT	-15.69'	7.76'	-7.93'	SEE NOTE
245	— BT	1850035.319	1177471.160	58.65 LT	SEE NOTE	SEE NOTE	-10.77'	SEE NOTE

VERIFIED UTILITY INFORMATION

TEST HOLE #	SIZE & TYPE	NORTHING	EASTING	OFFSET	TOP OF UTILITY	EXISTING CUT	REFERENCE GROUND ELEVATION	COMMENTS
246	— BT	1850041.470	1177650.061	59.00 RT	SEE NOTE	SEE NOTE	-10.84'	SEE NOTE
247	— BT	1871203.115	1175505.197	37.89 LT	SEE NOTE	SEE NOTE	-2.02'	SEE NOTE
248	— BT	1871203.917	1175514.392	28.66 LT	-8.46'	6.23'	-2.23'	SEE NOTE
249	— BT	1871206.409	1175554.544	11.57 RT	SEE NOTE	SEE NOTE	-1.77'	SEE NOTE
250	24" BT	1878879.409	1175747.664	54.72 LT	-16.06'	11.74'	-4.92'	SUE QUALITY LEVEL "A"
251	— BT	1875203.628	1176040.796	83.00 RT	-2.47'	12.66'	10.19'	SEE NOTE
252	24" BT	1875144.552	1175846.846	56.48 LT	-6.92'	14.45'	7.53'	SEE NOTE
253	24" BT	1878884.810	1175914.130	55.83 RT	-16.55'	11.45'	-5.10'	SUE QUALITY LEVEL "A"
254	30" E	1876039.562	1175820.570	58.56 LT	-8.64'	8.15'	-0.49'	SUE QUALITY LEVEL "A"

NOTES

- TH# 230 COULD NOT SEE DUCT DUE TO EXCESSIVE GROUND WATER BUT PROBED AND FELT SIDES AND TOP OF 48" WIDE DUCT.
- TH# 231 COULD NOT SEE DUCT DUE TO EXCESSIVE GROUND WATER BUT PROBED AND FELT SIDES AND TOP OF 24" WIDE DUCT.
- TH# 233 & 233A WE WERE NOT ABLE TO EXCAVATE ANY DEEPER THAN DEPTHS RECORDED DUE TO EXTREMELY HARD SOIL CONDITIONS. WE HAD A DIFFICULT TIME PIN POINTING DUCT PACKAGE ELECTRONICALLY, THIS IS THE REASON WHY WE ATTEMPTED MULTIPLE HOLES IN THIS LOCATION.
- TH# 234 & 235 NOT ABLE TO SEE PHONE DUCT DUE TO EXCESSIVE WATER AND SAND CAVING IN, BUT PROBED AND WERE ABLE TO FEEL BOTH SIDES AND TOP OF 24" WIDE DUCT.
- TH# 238 & 240 NOT ABLE TO SEE GAS MAIN, BUT WAS ABLE TO TO PROBE AND FEEL SIDES AND TOP OF 16" MAIN.
- TH# 239 NOT ABLE TO SEE GAS MAIN, BUT WAS ABLE TO TO PROBE AND FEEL SIDES AND TOP OF 50" MAIN.
- TH# 244 FOUND THE TOP OF A WOOD STRUCTURE (BOX), POSSIBLY ENCASED DUCT.
- TH# 245 UNABLE TO EXPOSE DUE TO HARD SOIL. TBE DID VACUUM TO A DEPTH OF 7' AND WAS ABLE TO PROBE TO A DEPTH OF 13'.
- TH# 246 UNABLE TO EXPOSE DUE TO HARD SOIL. TBE DID VACUUM TO A DEPTH OF 8' AND WAS ABLE TO PROBE TO A DEPTH OF 14'.
- TH# 247 UNABLE TO EXPOSE DUE TO LARGE ROCKS AND WATER. CLEARANCE DEPTH OF 4.70'.
- TH# 248 FOUND BIG SLAB OF CONCRETE WITH NO FORM, POSSIBLY POURED OVER PHONE DUCT.
- TH# 249 UNABLE TO EXPOSE DUE TO CAVE-INS AND WATER. CLEARANCE DEPTH OF 5.79'.
- TH# 251 UNABLE TO EXPOSE DUE TO CAVE-INS AND WATER. PROBED AND FELT DUCT AT 12.66'.
- TH# 252 UNABLE TO EXPOSE DUE TO CAVE-INS AND WATER. PROBED AND FELT TOP AND SIDES OF DUCT AT 14.45'.

ALL INFORMATION SHOWN WAS OBTAINED FROM A LOCATION SURVEY.

Illinois Department of Transportation

I-90 /94 (NB & SB of Dan Ryan Expressway)
Chicago-Cook County
Sec No: (2122-921 PT1) R, (2021-922 PT1,2)
Contract No. 62584, 62585, 62586, 62589, 62593, 62693, 62694, 62695
62300, 62301, 62303, 62304
TBE Project No.: IL09500164, 167, 168, 170, 171, 179, 180, 182, 204, 205,
206, 211, 212, 219, 221, 225, 226, 227, 228, 230, 232, 235, 237, 238, 248, 249
250, 251, 252

DATE		BY	DESCRIPTION	DATE		BY	DESCRIPTION	DATE		BY	DESCRIPTION	DATE		BY	DESCRIPTION
3/16/06		SA													

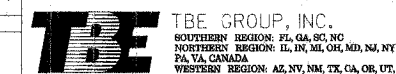

VERIFIED
UTILITY
LOCATIONS

F.A.I. RTE.	SECTION	COUNTY	TOTAL SHEETS	SHEET NO.
90/94	*	COOK	565	207
STA. 4474+50	TO STA. 4479+00			
FED. ROAD DIST. NO. 1 ILLINOIS		FED. AID PROJECT		
62301		(2021-922 PT2 ETC 2324.6-1P) R-10		

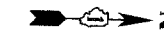

LEGEND:

- (CG) LONGITUDINAL CURB AND GUTTER JOINT - NO. 6 EPOXY COATED TIE BARS, 24" LONG AT 24" C-C
 - (C) SAWED TRANSVERSE CONTRACTION PINT
 - (EX) TRANSVERSE EXPANSION JOINT
 - (BR) NO BARS, KEYED LONGITUDINAL CONSTRUCTION JOINT WITH ALL KEYS FACING ONE DIRECTION ALONG INSIDE EDGE OF RAMP PAVEMENT AND SURROUNDING GORE
 - (J) LONGITUDINAL SAWED JOINT - NO. 6 EPOXY COATED TIE BARS, 30" LONG AT 30" C-C
LONGITUDINAL CONSTRUCTION JOINT - NO. 8 EPOXY COATED TIE BARS, 24" LONG AT 24" C-C
 - (SL) LONGITUDINAL SHOULDER CONSTRUCTION JOINT - NO. 8 EPOXY COATED TIE BARS, 30" LONG AT 24" C-C
 - (ST) TRANSVERSE SHOULDER CONTRACTION JOINT
- SPACED 15' C-C ALONG OUTSIDE SHOULDER
- SPACED 20' C-C AT ALL OTHER LOCATIONS
- SWALE

GARFIELD BLVD
EASTBOUND

GARFIELD BLVD
WESTBOUND

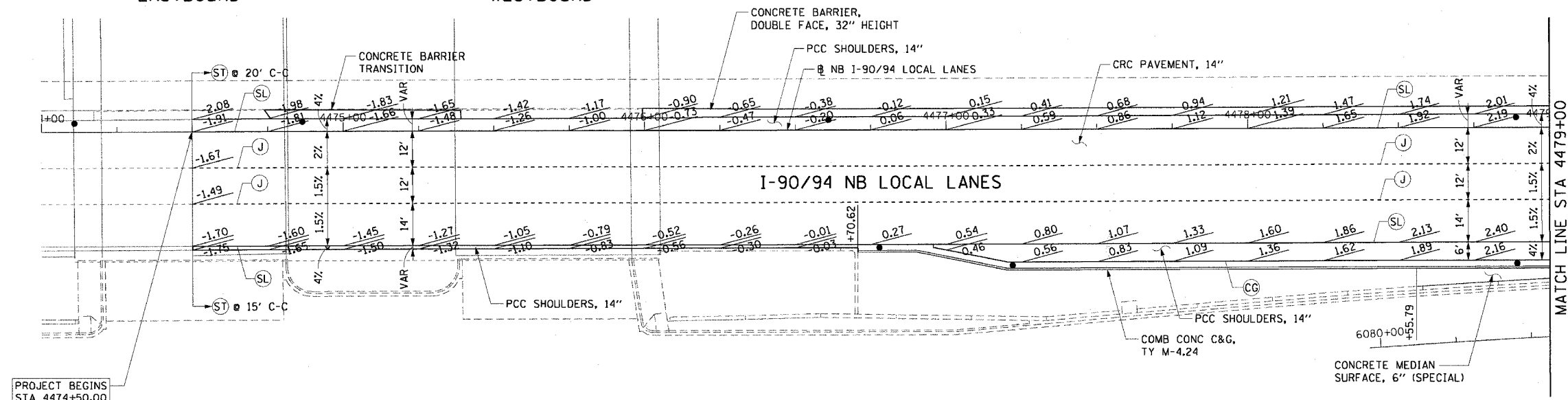

NOTES:

1. SEE ALIGNMENT AND TIES SHEETS FOR CURVE INFORMATION.
2. SEE ROADWAY PLAN SHEETS FOR BEGINNING AND END TAPER STATIONS AND TAPER RATES.
3. PAVEMENT ELEVATIONS ARE SHOWN AT 25' INTERVALS.
4. SEE ROADWAY DETAIL RDT-B FOR THE TYING OF THE MEDIAN BARRIER BASE TO THE PCC SHOULDER.
5. AT THE PROJECT LIMITS, THE CONTRACTOR SHALL MEET THE FUTURE ROADWAY ELEVATIONS AND TRANSVERSE SHOULDER CONTRACTION JOINT SPACING OF CONTRACT 60A62.

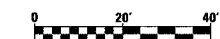

JE-1

REVISIONS		ILLINOIS DEPARTMENT OF TRANSPORTATION F.A.I. 90/94 (DAN RYAN EXPRESSWAY) GARFIELD BLVD TO 31ST STREET (NB LOCAL LANES) PAVEMENT JOINTING AND ELEVATION PLANS
NAME	DATE	

SCALE: 1"=20'
DATE: June 9, 2006

DRAWN BY: PHP
CHECKED BY: NJH

CTE | AECOM

P:\P\04065\GAIN\08\cfrs 18 & 19\sta\cfr. 18\p\je sheets\p\je sheets.dwg

6/7/2006 1:47:09 PM

F.A.I. RTE.	SECTION	COUNTY	TOTAL SHEETS	SHEET NO.
90/94	*	COOK	565	208
STA. 4479+00	TO STA. 4489+00			
FED. ROAD DIST. NO. 1 ILLINOIS		FED. AID PROJECT		
62301		* (2021-922 PT2 ETC 2324.6-1P) R-10		



LEGEND:

- (CG) LONGITUDINAL CURB AND GUTTER JOINT - NO. 6 EPOXY COATED TIE BARS, 24" LONG AT 24" C-C
- (C) SAWED TRANSVERSE CONTRACTION PINT
- (EX) TRANSVERSE EXPANSION JOINT
- (GR) NO BARS, KEYED LONGITUDINAL CONSTRUCTION JOINT WITH ALL KEYS FACING ONE DIRECTION ALONG INSIDE EDGE OF RAMP PAVEMENT AND SURROUNDING GORE
- (J) LONGITUDINAL SAWED JOINT - NO. 6 EPOXY COATED TIE BARS, 30" LONG AT 30" C-C
LONGITUDINAL CONSTRUCTION JOINT - NO. 8 EPOXY COATED TIE BARS, 24" LONG AT 24" C-C
- (SL) LONGITUDINAL SHOULDER CONSTRUCTION JOINT - NO. 8 EPOXY COATED TIE BARS, 30" LONG AT 24" C-C
- (ST) TRANSVERSE SHOULDER CONTRACTION JOINT
- SWALE

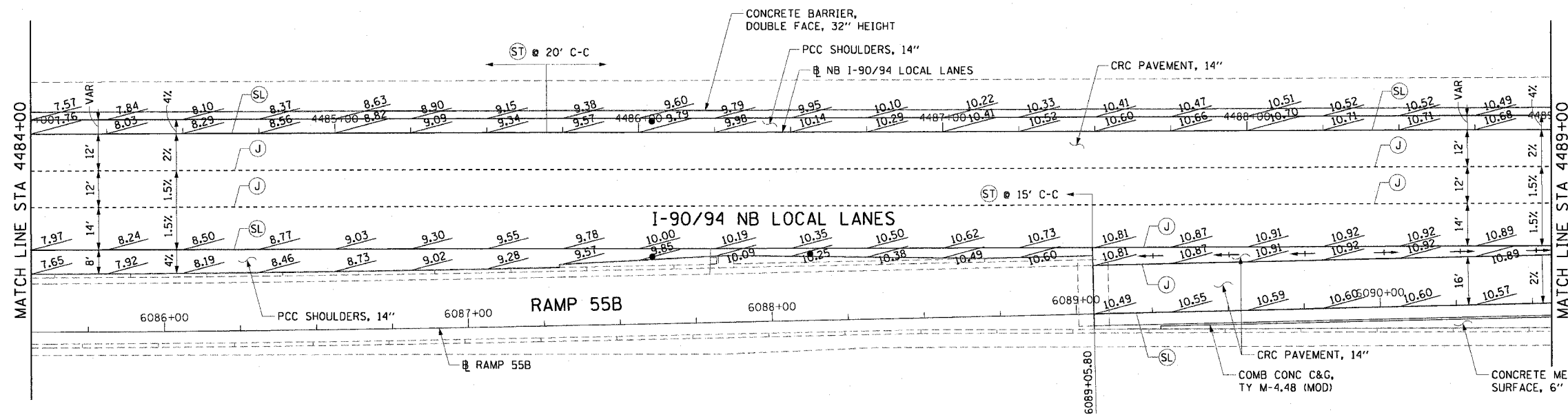
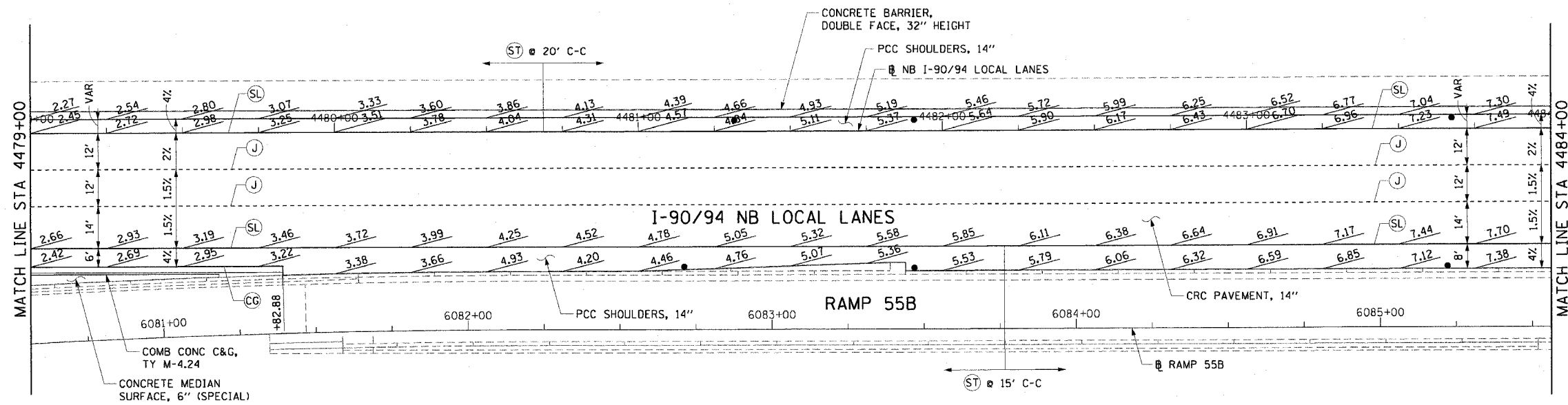

NOTES:

1. SEE ALIGNMENT AND TIES SHEETS FOR CURVE INFORMATION.
2. SEE ROADWAY PLAN SHEETS FOR BEGINNING AND END TAPER STATIONS AND TAPER RATES.
3. PAVEMENT ELEVATIONS ARE SHOWN AT 25' INTERVALS.
4. SEE ROADWAY DETAIL RDT-8 FOR THE TYING OF THE MEDIAN BARRIER BASE TO THE PCC SHOULDER.
5. TRANSITION FROM 4% SHOULDER SLOPE TO 1.5% GORE SLOPE AT A DISTANCE OF 25' FROM THE START OF THE GORE.

SWALE ELEVATIONS		
STATION	OFFSET	ELEVATION
4487+49.14	40.99' RT	10.76
+50.00	40.99' RT	10.76
+75.00	40.74' RT	10.83
4488+00.00	40.49' RT	10.87
+25.00	40.24' RT	10.89
+50.00	39.99' RT	10.89
+75.00	49.74' RT	10.86



JE-2

REVISIONS	
NAME	DATE

ILLINOIS DEPARTMENT OF TRANSPORTATION
 F.A.I. 90/94 (DAN RYAN EXPRESSWAY)
 GARFIELD BLVD TO 31ST STREET (NB LOCAL LANES)
PAVEMENT JOINTING AND ELEVATION PLANS

SCALE: 1"=20'
 DATE: June 9, 2006
 DRAWN BY: PHP
 CHECKED BY: NJH



6/7/2006 1:47:11 PM I:\P060666\civil\plans\18 & 19\swale\18\p060666\18\p060666.dwg

F.A.I. RTE.	SECTION	COUNTY	TOTAL SHEETS	SHEET NO.
90/94	*	COOK	565	209
STA. 4489+00		TO STA. 4499+00		
FED. ROAD DIST. NO. 1 ILLINOIS FED. AID PROJECT				
62301 (2021-922 PT2 ETC 2324.6-1P) R-10				

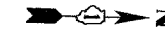

LEGEND:

- ⊙ LONGITUDINAL CURB AND GUTTER JOINT - NO. 6 EPOXY COATED TIE BARS, 24" LONG AT 24" C-C
- ⊙ SAWED TRANSVERSE CONTRACTION JOINT
- ⊙ TRANSVERSE EXPANSION JOINT
- ⊙ NO BARS, KEYED LONGITUDINAL CONSTRUCTION JOINT WITH ALL KEYS FACING ONE DIRECTION ALONG INSIDE EDGE OF RAMP PAVEMENT AND SURROUNDING GORE
- ⊙ LONGITUDINAL SAWED JOINT - NO. 6 EPOXY COATED TIE BARS, 30" LONG AT 30" C-C
- ⊙ LONGITUDINAL CONSTRUCTION JOINT - NO. 8 EPOXY COATED TIE BARS, 24" LONG AT 24" C-C
- ⊙ LONGITUDINAL SHOULDER CONSTRUCTION JOINT - NO. 8 EPOXY COATED TIE BARS, 30" LONG AT 24" C-C
- ⊙ TRANSVERSE SHOULDER CONTRACTION JOINT
- SWALE

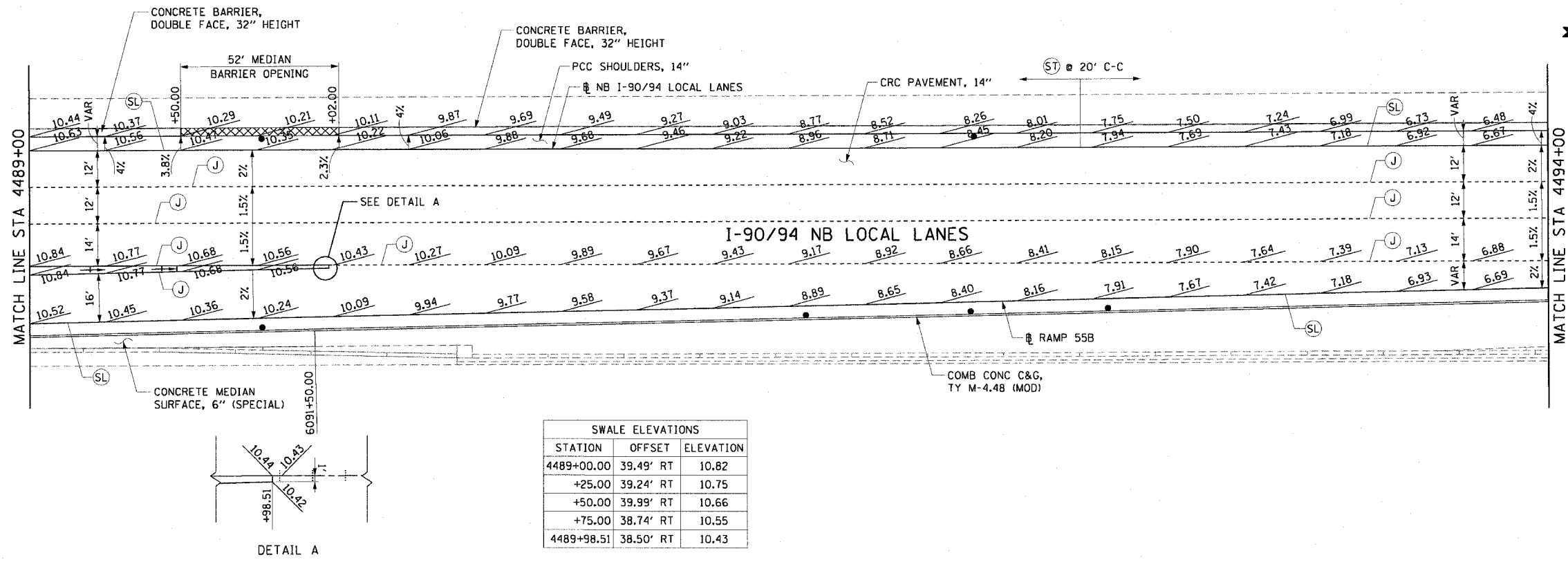

STATION	OFFSET	ELEVATION
4489+00.00	39.49' RT	10.82
+25.00	39.24' RT	10.75
+50.00	39.99' RT	10.66
+75.00	38.74' RT	10.55
4489+98.51	38.50' RT	10.43

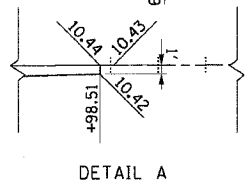

NOTES:

1. SEE ALIGNMENT AND TIES SHEETS FOR CURVE INFORMATION.
2. SEE ROADWAY PLAN SHEETS FOR BEGINNING AND END TAPER STATIONS AND TAPER RATES.
3. PAVEMENT ELEVATIONS ARE SHOWN AT 25' INTERVALS.
4. SEE ROADWAY DETAIL RDT-8 FOR THE TYING OF THE MEDIAN BARRIER BASE TO THE PCC SHOULDER.
5. AT THE MEDIAN BARRIER OPENING, THE ELEVATION OF THE LOCAL LANE EDGE OF SHOULDER SHALL MATCH THE ELEVATION OF THE EXPRESS LANE EDGE OF SHOULDER.

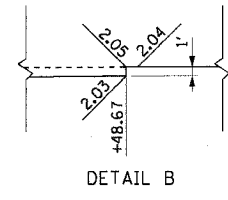
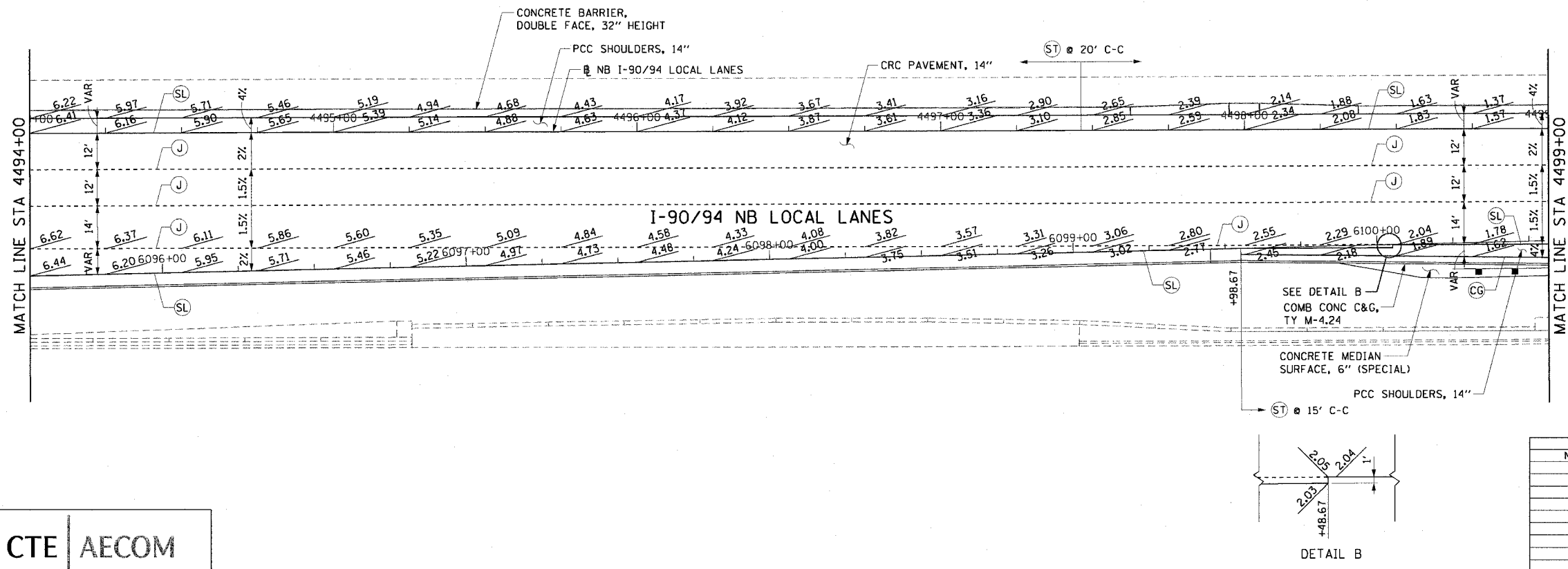

REVISIONS	
NAME	DATE

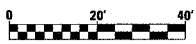

ILLINOIS DEPARTMENT OF TRANSPORTATION
 F.A.I. 90/94 (DAN RYAN EXPRESSWAY)
 GARFIELD BLVD TO 31ST STREET (NB LOCAL LANES)
 PAVEMENT JOINTING AND ELEVATION PLANS

SCALE: 1"=20'
 DATE: June 9, 2006

DRAWN BY: PHP
 CHECKED BY: NJH

F.A.I. RTE.	SECTION	COUNTY	TOTAL SHEETS	SHEET NO.
90/94	*	COOK	565	211
STA. 4509+00	TO STA. 4519+00			
FED. ROAD DIST. NO. 1	ILLINOIS	FED. AID PROJECT		
62301	* (2021-922 PT2 ETC 2324.6-1P) R-10			

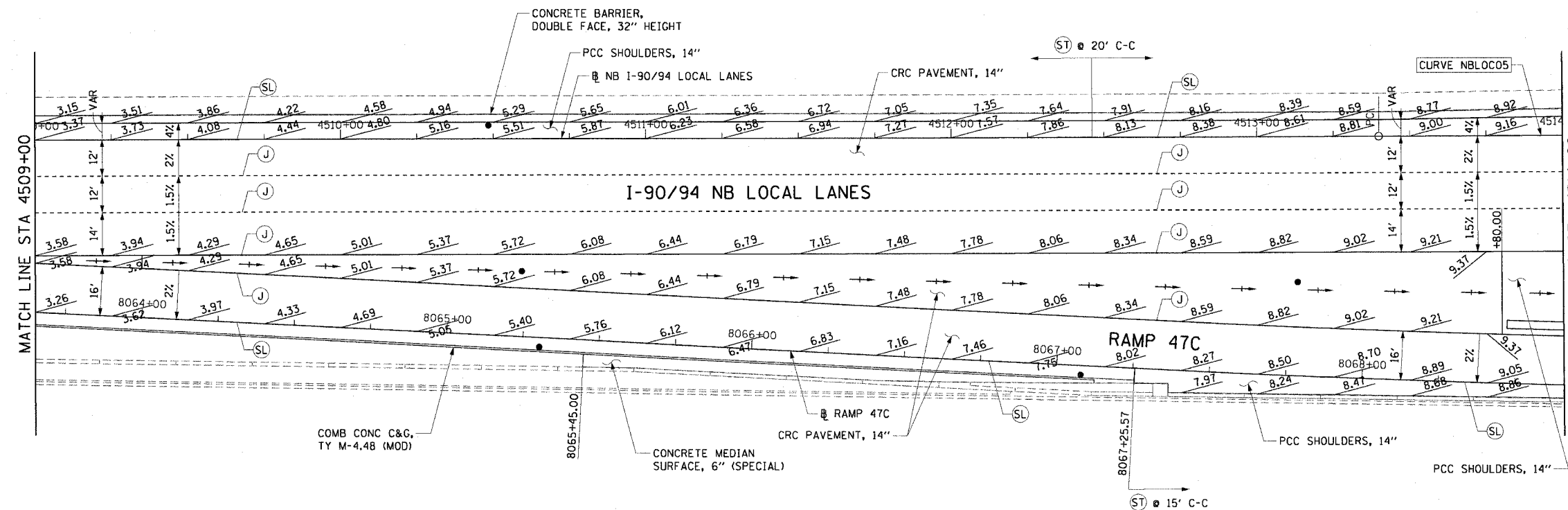

LEGEND:

- (CC) LONGITUDINAL CURB AND GUTTER JOINT - NO. 6 EPOXY COATED TIE BARS, 24" LONG AT 24" C-C
- (C) SAWED TRANSVERSE CONTRACTION PINT
- (EX) TRANSVERSE EXPANSION JOINT
- (GR) NO BARS, KEYED LONGITUDINAL CONSTRUCTION JOINT WITH ALL KEYS FACING ONE DIRECTION ALONG INSIDE EDGE OF RAMP PAVEMENT AND SURROUNDING GORE
- (J) LONGITUDINAL SAWED JOINT - NO. 6 EPOXY COATED TIE BARS, 30" LONG AT 30" C-C
- (J) LONGITUDINAL CONSTRUCTION JOINT - NO. 8 EPOXY COATED TIE BARS, 24" LONG AT 24" C-C
- (SL) LONGITUDINAL SHOULDER CONSTRUCTION JOINT - NO. 8 EPOXY COATED TIE BARS, 30" LONG AT 24" C-C
- (ST) TRANSVERSE SHOULDER CONTRACTION JOINT
- SWALE

NOTES:

1. SEE ALIGNMENT AND TIES SHEETS FOR CURVE INFORMATION.
2. SEE ROADWAY PLAN SHEETS FOR BEGINNING AND END TAPER STATIONS AND TAPER RATES.
3. PAVEMENT ELEVATIONS ARE SHOWN AT 25' INTERVALS.
4. SEE ROADWAY DETAIL RDT-8 FOR THE TYING OF THE MEDIAN BARRIER BASE TO THE PCC SHOULDER.

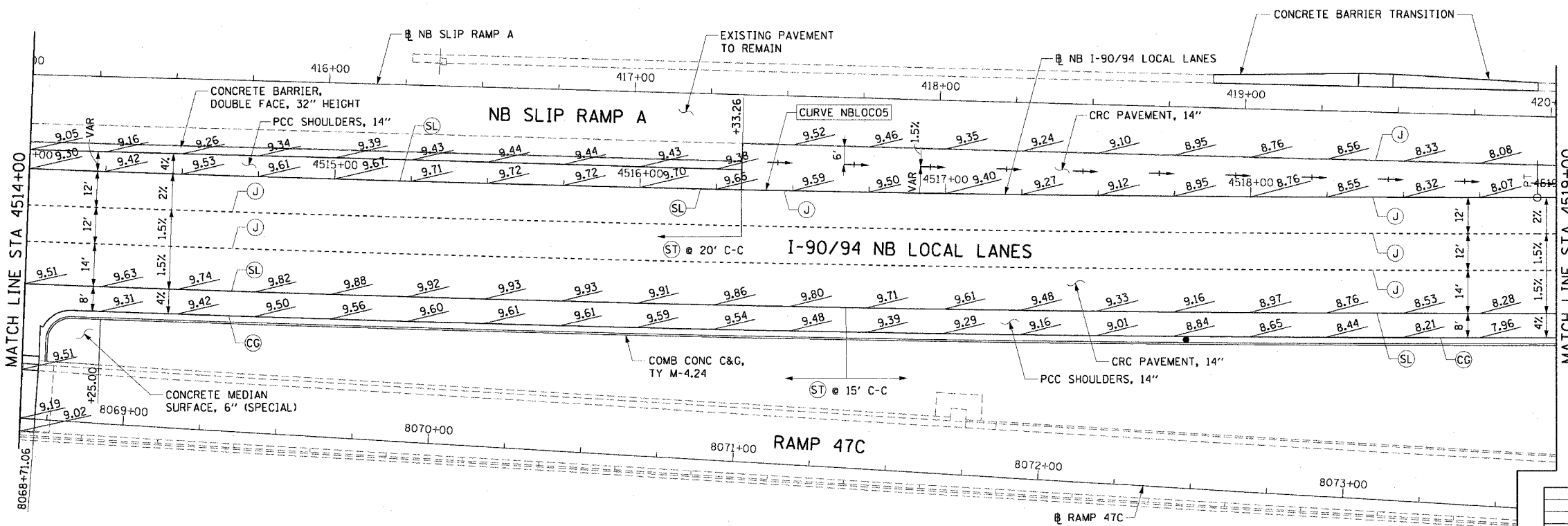

NOTES CONT.:

5. TRANSITION FROM 4% SHOULDER SLOPE TO 1.5% GORE SLOPE AT A DISTANCE OF 25' FROM THE START OF THE GORE.
6. SEE SHEET JE-4 FOR SWALE ELEVATIONS OF THE RAMP 47C GORE AREA.

SWALE ELEVATIONS		
STATION	OFFSET	ELEVATION
4516+33.26	9.25' LT	9.48
+50.00	9.12' LT	9.43
+75.00	8.87' LT	9.37
4517+00.00	8.58' LT	9.26
+25.00	8.24' LT	9.15
+50.00	7.85' LT	9.01
+75.00	7.42' LT	8.85
4518+00.00	6.93' LT	8.67
+25.00	6.40' LT	8.47
+50.00	5.82' LT	8.24
+75.00	5.19' LT	7.99
4519+00.00	4.52' LT	7.72

REVISIONS	
NAME	DATE

ILLINOIS DEPARTMENT OF TRANSPORTATION
 F.A.I. 90/94 (DAN RYAN EXPRESSWAY)
 GARFIELD BLVD TO 31ST STREET (NB LOCAL LANES)
 PAVEMENT JOINTING AND ELEVATION PLANS

SCALE: 1"=20'
 DATE: June 9, 2006

DRAWN BY: PHP
 CHECKED BY: NJH

CTE | AECOM

6/7/2006 14:25 PM

F.A.I. RTE.	SECTION	COUNTY	TOTAL SHEETS	SHEET NO.
90/94	*	COOK	565	212
STA. 4519+00	TO STA. 4529+00			
FED. ROAD DIST. NO. 1 ILLINOIS FED. AID PROJECT				
62301 * (2021-922 PT2 ETC 2324.6-1P) R-10				

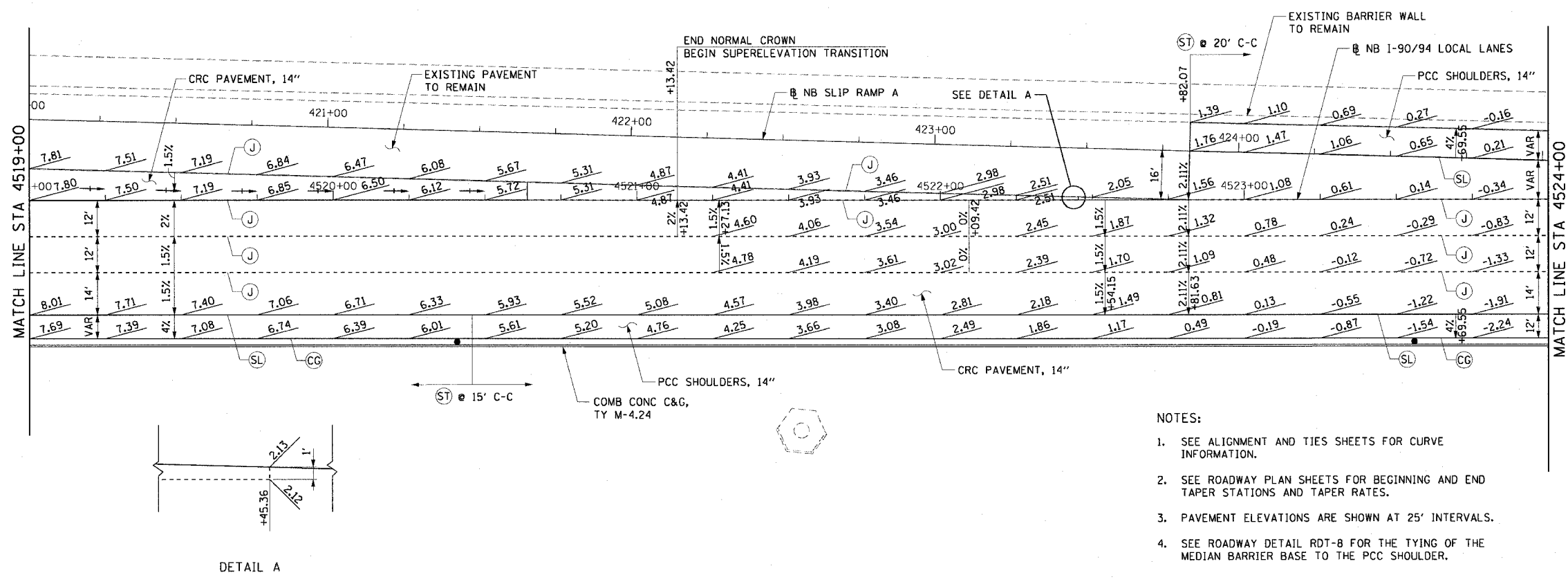
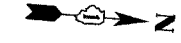

- LEGEND:
- (CG) LONGITUDINAL CURB AND GUTTER JOINT - NO. 6 EPOXY COATED TIE BARS, 24" LONG AT 24" C-C
 - (C) SAWED TRANSVERSE CONTRACTION PINT
 - (EX) TRANSVERSE EXPANSION JOINT
 - (GR) NO BARS, KEYED LONGITUDINAL CONSTRUCTION JOINT WITH ALL KEYS FACING ONE DIRECTION ALONG INSIDE EDGE OF RAMP PAVEMENT AND SURROUNDING GORE
 - (J) LONGITUDINAL SAWED JOINT - NO. 6 EPOXY COATED TIE BARS, 30" LONG AT 30" C-C
LONGITUDINAL CONSTRUCTION JOINT - NO. 8 EPOXY COATED TIE BARS, 24" LONG AT 24" C-C
 - (SL) LONGITUDINAL SHOULDER CONSTRUCTION JOINT - NO. 8 EPOXY COATED TIE BARS, 30" LONG AT 24" C-C
 - (ST) TRANSVERSE SHOULDER CONTRACTION JOINT
 - SWALE

- NOTES:
1. SEE ALIGNMENT AND TIES SHEETS FOR CURVE INFORMATION.
 2. SEE ROADWAY PLAN SHEETS FOR BEGINNING AND END TAPER STATIONS AND TAPER RATES.
 3. PAVEMENT ELEVATIONS ARE SHOWN AT 25' INTERVALS.
 4. SEE ROADWAY DETAIL RDT-8 FOR THE TYING OF THE MEDIAN BARRIER BASE TO THE PCC SHOULDER.

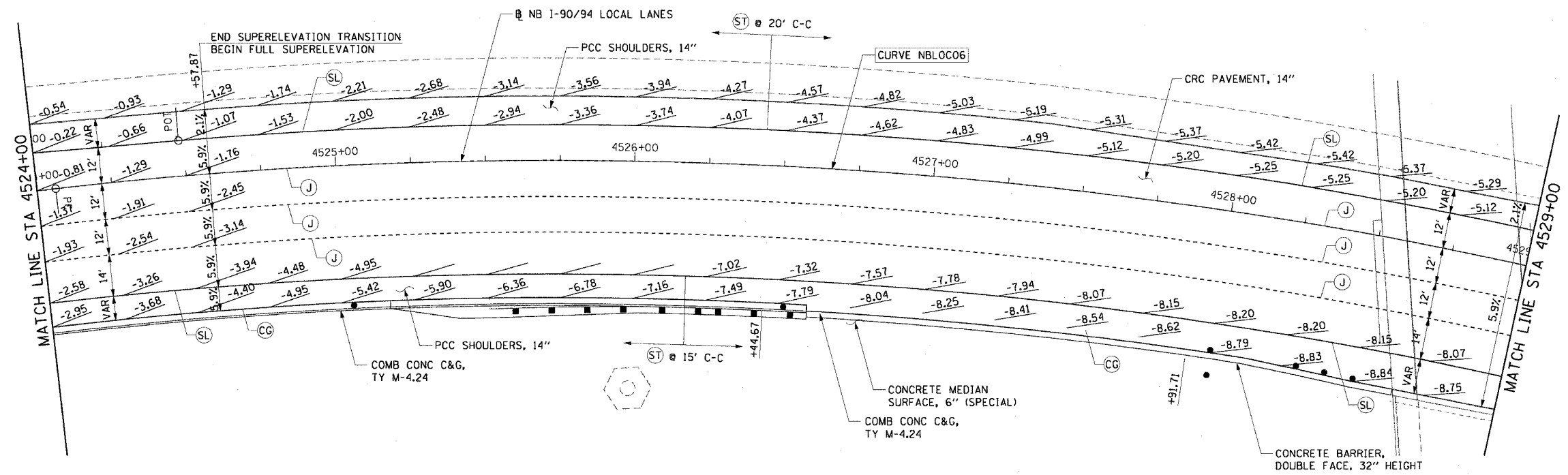

SWALE ELEVATIONS		
STATION	OFFSET	ELEVATION
4519+25.00	3.83' LT	7.42
+50.00	3.14' LT	7.10
+75.00	3.00' LT	6.76
4520+00.00	3.00' LT	6.40
+25.00	3.00' LT	6.02
+50.00	3.00' LT	5.61
+75.00	2.85' LT	5.26
4521+00.00	2.50' LT	4.83
+25.00	2.16' LT	4.37
+50.00	1.81' LT	3.90
+75.00	1.47' LT	3.44
4522+00.00	1.12' LT	2.97
+25.00	0.78' LT	2.50
+45.36	0.50' LT	2.11

REVISIONS	
NAME	DATE

ILLINOIS DEPARTMENT OF TRANSPORTATION
 F.A.I. 90/94 (DAN RYAN EXPRESSWAY)
 GARFIELD BLVD TO 31ST STREET (NB LOCAL LANES)
 PAVEMENT JOINTING AND ELEVATION PLANS

SCALE: 1"=20'
 DATE: June 9, 2006

DRAWN BY: PHP
 CHECKED BY: NJH

CTE | AECOM

JE-6
 6/7/2006 1:43:37 PM

F.A.I.	SECTION	COUNTY	TOTAL SHEETS	SHEET NO.
94/90	COOK	565	213	
STA. TO STA.		FED. ROAD DIST. NO. ILLINOIS FED. AID PROJECT		
62301		• (2021-922 PT2 ETC 2324.6-IP) R-10		



- LEGEND:**
- (CG) LONGITUDINAL CONSTRUCTION JOINT PER STANDARD 606001 WITH DRILLED & GROUTED 24" LONG TIE BARS
 - (C) SAWED TRANSVERSE CONTRACTION JOINT PER STANDARD 420001 WITH HOT POUR SEAL
 - (EX) TRANSVERSE EXPANSION JOINT PER STANDARD 420001
 - (GR) NO BARS, KEYED LONGITUDINAL CONSTRUCTION JOINT WITH ALL KEYS FACING ONE DIRECTION ALONG INSIDE EDGE OF RAMP PAVEMENT AND SURROUNDING SHOULDER GORE
 - (F) LONGITUDINAL CONSTRUCTION JOINT WITH DRILLED & GROUTED #8 DEFORMED EPOXY COATED TIE BARS, 24" LONG AT 24" C-C
 - (J) LONGITUDINAL SAWED JOINT PER STANDARD 420001
 - (SL) LONGITUDINAL CONSTRUCTION JOINT PER STANDARD 420001 EXCEPT FOR DRILLED & GROUTED 24" LONG #8 TIE BARS. SEAL PER ASTM D 3405
 - (ST) LONGITUDINAL CONSTRUCTION JOINT PER STANDARD 483001 EXCEPT FOR DRILLED & GROUTED 30" LONG #8 TIE BARS
 - (ST) SAWED TRANSVERSE SHOULDER CONTRACTION JOINT PER STANDARD 483001 (MATCH RAMP PAVEMENT JOINTS IN GORE AREAS)
 - SPACED 15' C-C ALONG OUTSIDE SHOULDER
 - SPACED 20' C-C AT ALL OTHER LOCATIONS

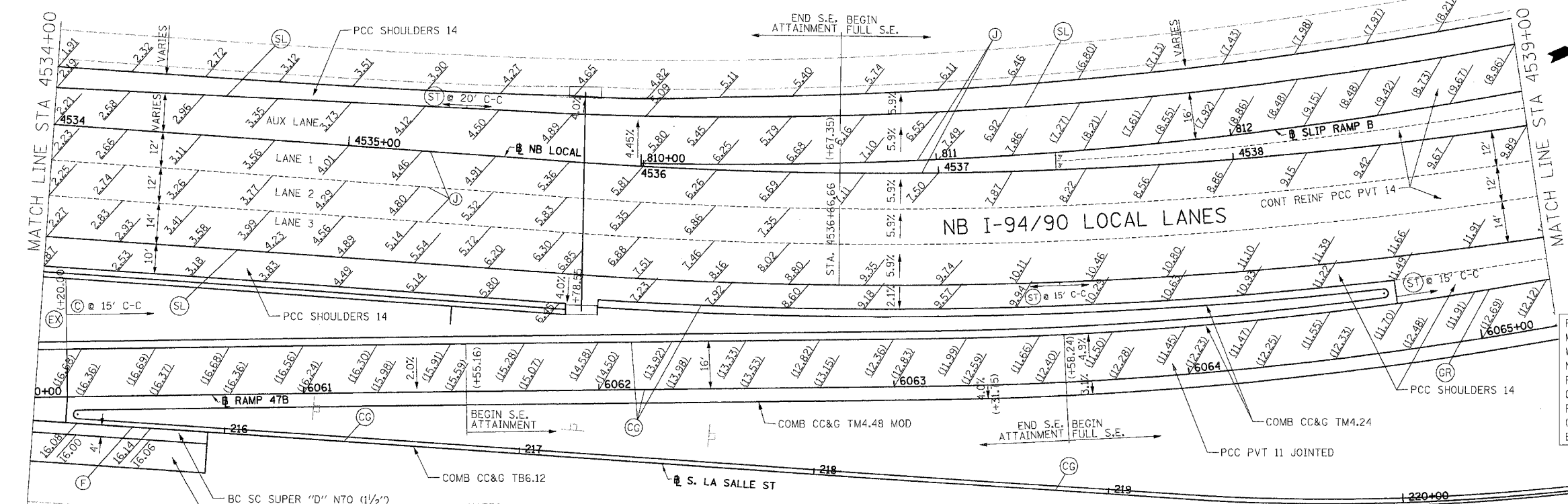
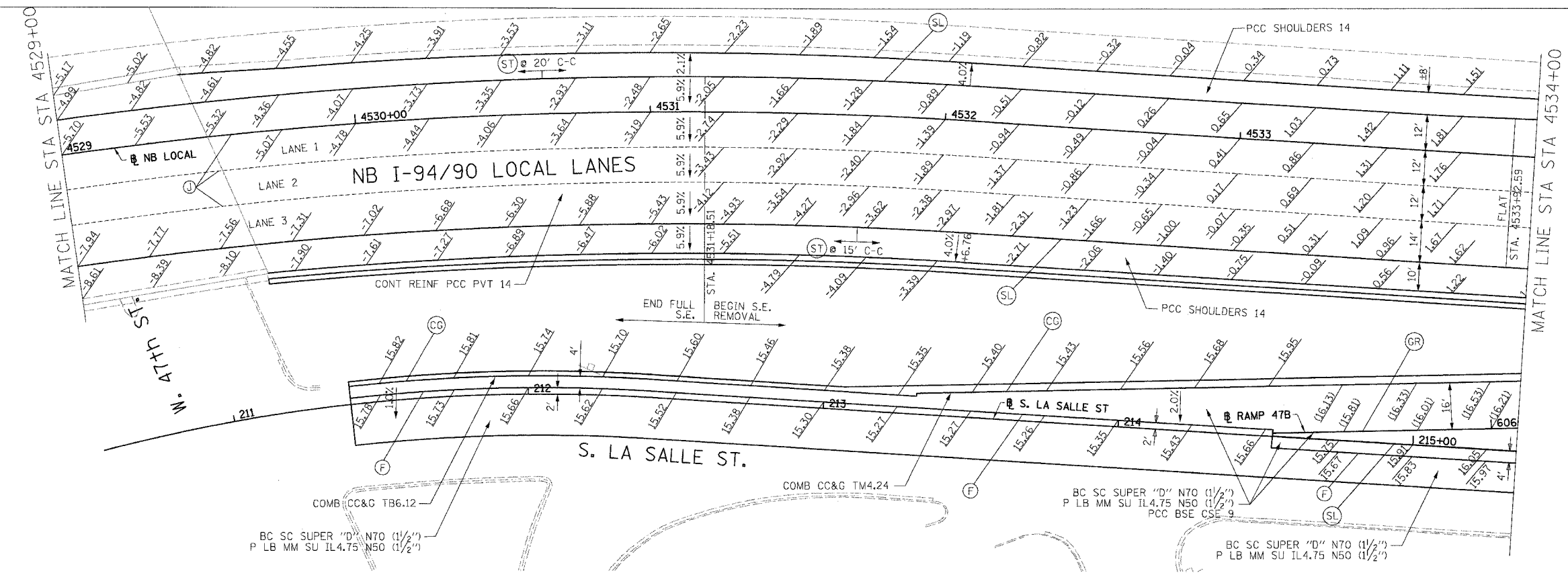

SWALE ELEVATIONS		
STA	OFFSET	ELEVATION
4538+50		
+75		

FOR PARTIAL WIDTH FRONTAGE ROAD IMPROVEMENTS, EITHER MATCH TRANSVERSE JOINT SPACING OF EXISTING PAVEMENT WITH NEWLY INSTALLED TRANSVERSE JOINTS OR PLACE NEWLY INSTALLED TRANSVERSE JOINTS AT 15'-0" INTERVALS. PLACE NEWLY INSTALLED TRANSVERSE JOINTS AT THE GREATER OF THESE TWO INTERVALS. SEE DETAIL SHEETS RDT-18A AND RDT-18B FOR PCC BASE COURSE JOINT DETAILS. (INCLUDED IN THE COST OF PORTLAND CEMENT CONCRETE BASE COURSE 9")

- NOTES:**
- ELEVATION STATIONED OFF OF NB I-94/90 LOCAL LANES OR S. LA SALLE ST.
 - ELEVATION STATIONED OFF OF RAMP ALIGNMENT
 - SEE ALIGNMENT AND TIES SHEETS FOR CURVE INFORMATION
 - SEE ROADWAY PLAN SHEETS FOR BEGINNING AND END TAPER STATIONS AND TAPER RATES.
 - PAVEMENT ELEVATIONS ALONG EDGE OF PAVEMENTS, EDGE OF SHOULDERS, GORES, RAMPS AND IN AREAS OF SUPERELEVATION TRANSITION ARE PROVIDED AT 25' INTERVALS, FOR ALL ELEVATIONS, REFER TO THE PROFILES AND TYPICAL SECTIONS.
 - SEE ROADWAY DETAIL RDT-8 FOR THE TYING OF THE MEDIAN BARRIER BASE TO THE PCC SHOULDER.

BOWMAN, BARRETT & ASSOCIATES INC.
CONSULTING ENGINEERS
Chicago, Illinois
312.228.0100
www.bbainc.com

REVISIONS	
NAME	DATE
REVISED	6/23/06

ILLINOIS DEPARTMENT OF TRANSPORTATION
F.A.I. 94/90 (DAN RYAN EXPRESSWAY)
GARFIELD BLVD TO 31ST STREET (NB LOCAL LANES)
**PAVEMENT JOINTING
AND ELEVATION PLANS**

SCALE: 1"=20'
DATE: 06/09/06

DRAWN BY: JDC
CHECKED BY: RS

6/23/2006 10:26 AM

F.A.I.	SECTION	COUNTY	TOTAL SHEETS	SHEET NO.
94/90	*	COOK	565	214
STA.	TO STA.			
FED. ROAD DIST. NO.	ILLINOIS	FED. AID PROJECT		
62301		(2021-922 PT2 ETC 2324.6-1P) R-10		

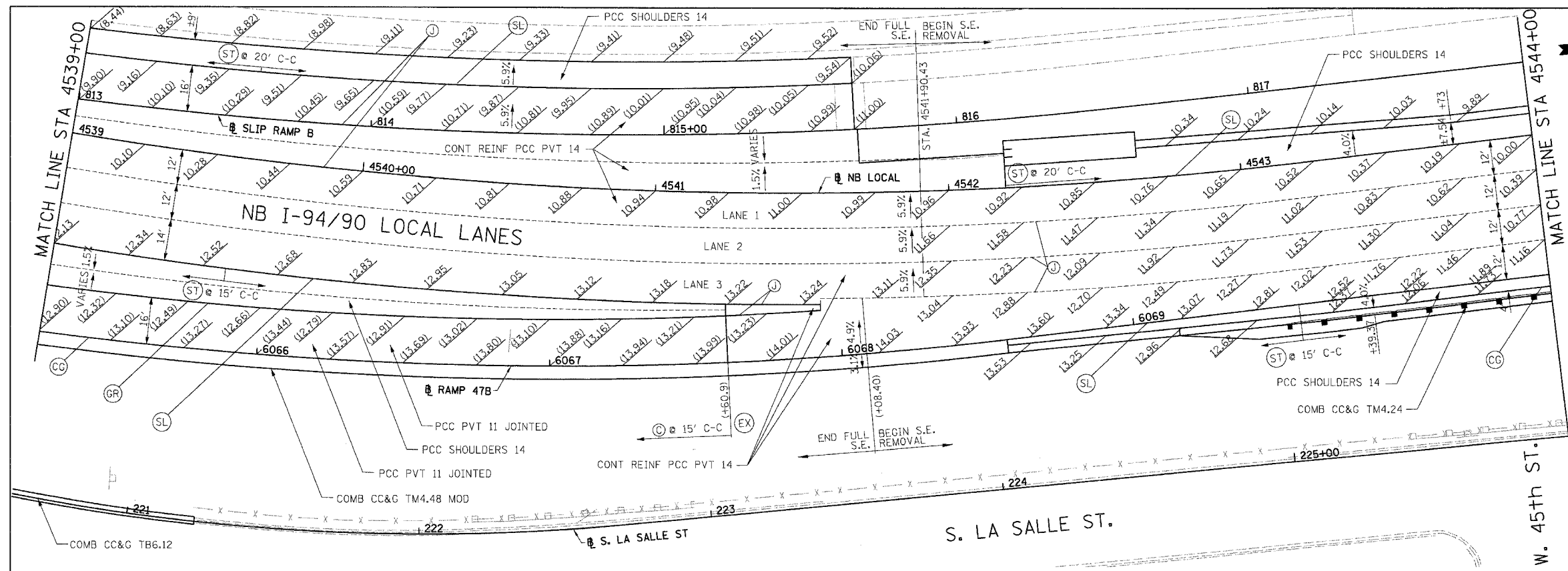

- LEGEND:
- (CG) LONGITUDINAL CONSTRUCTION JOINT PER STANDARD 606001 WITH DRILLED & GROUTED 24" LONG TIE BARS
 - (C) SAWED TRANSVERSE CONTRACTION JOINT PER STANDARD 420001 WITH HOT POUR SEAL
 - (EX) TRANSVERSE EXPANSION JOINT PER STANDARD 420001
 - (GR) NO BARS, KEYED LONGITUDINAL CONSTRUCTION JOINT WITH ALL KEYS FACING ONE DIRECTION ALONG INSIDE EDGE OF RAMP PAVEMENT AND SURROUNDING SHOULDER GORE
 - (F) LONGITUDINAL CONSTRUCTION JOINT WITH DRILLED & GROUTED #8 DEFORMED EPOXY COATED TIE BARS, 24" LONG AT 24" C-C
 - (J) LONGITUDINAL SAWED JOINT PER STANDARD 420001
 - (L) LONGITUDINAL CONSTRUCTION JOINT PER STANDARD 420001 EXCEPT FOR DRILLED & GROUTED 24" LONG #8 TIE BARS. SEAL PER ASTM D 3405
 - (SL) LONGITUDINAL CONSTRUCTION JOINT PER STANDARD 483001 EXCEPT FOR DRILLED & GROUTED 30" LONG #8 TIE BARS
 - (ST) SAWED TRANSVERSE SHOULDER CONTRACTION JOINT PER STANDARD 483001 (MATCH RAMP PAVEMENT JOINTS IN GORE AREAS)
 - SPACED 15' C-C ALONG OUTSIDE SHOULDER
 - SPACED 20' C-C AT ALL OTHER LOCATIONS

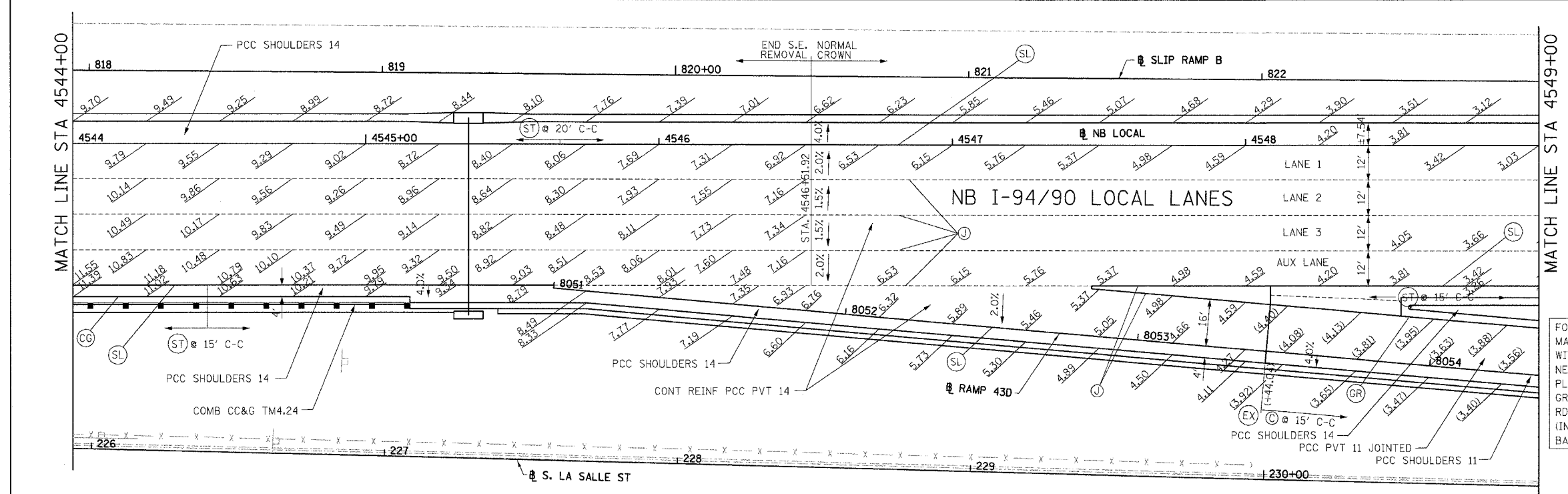

SWALE ELEVATIONS		
STA	OFFSET	ELEVATION
4539+00	+25	
	+50	
	+75	
4540+00	+25	
	+50	
	+75	
4541+00	+25	

SWALE ELEVATIONS		
STA	OFFSET	ELEVATION
4548+08	+25	
	+50	
	+75	
	+91	

FOR PARTIAL WIDTH FRONTAGE ROAD IMPROVEMENTS, EITHER MATCH TRANSVERSE JOINT SPACING OF EXISTING PAVEMENT WITH NEWLY INSTALLED TRANSVERSE JOINTS OR PLACE NEWLY INSTALLED TRANSVERSE JOINTS AT 15'-0" INTERVALS. PLACE NEWLY INSTALLED TRANSVERSE JOINTS AT THE GREATER OF THESE TWO INTERVALS. SEE DETAIL SHEETS RDT-18A AND RDT-18B FOR PCC BASE COURSE JOINT DETAILS. (INCLUDED IN THE COST OF 'PORTLAND CEMENT CONCRETE BASE COURSE 9")

- NOTES:
- ELEVATION STATIONED OFF OF NB I-94/90 LOCAL LANES OR S. LA SALLE ST.
 - ELEVATION STATIONED OFF OF RAMP ALIGNMENT
 - SEE ALIGNMENT AND TIES SHEETS FOR CURVE INFORMATION
 - SEE ROADWAY PLAN SHEETS FOR BEGINNING AND END TAPER STATIONS AND TAPER RATES.
 - PAVEMENT ELEVATIONS ALONG EDGE OF PAVEMENTS, EDGE OF SHOULDERS, GORES, RAMPS AND IN AREAS OF SUPERELEVATION TRANSITION ARE PROVIDED AT 25' INTERVALS, FOR ALL ELEVATIONS, REFER TO THE PROFILES AND TYPICAL SECTIONS.
 - SEE ROADWAY DETAIL RDT-8 FOR THE TYING OF THE MEDIAN BARRIER BASE TO THE PCC SHOULDER.

BOWMAN, BARRETT & ASSOCIATES INC.
CONSULTING ENGINEERS
Chicago, Illinois
312.228.0100
www.bbainc.com

REVISIONS	
NAME	DATE
REVISED	6/23/06

ILLINOIS DEPARTMENT OF TRANSPORTATION
F.A.I. 94/90 (DAN RYAN EXPRESSWAY)
GARFIELD BLVD TO 31ST STREET (NB LOCAL LANES)
PAVEMENT JOINTING
AND ELEVATION PLANS

SCALE: 1"=20'
DATE: 06/09/06

DRAWN BY: JDC
CHECKED BY: RS

6/23/2006 10:25:56 AM

F.A.I.	SECTION	COUNTY	TOTAL SHEETS	SHEET NO.
94/90		COOK	565	215
STA.	TO STA.			
FED. ROAD DIST. NO.	ILLINOIS	FED. AID PROJECT		
62301 • (2021-922 PT2 ETC 2324.6-1P) R-10				

- LEGEND:
- (CG) LONGITUDINAL CONSTRUCTION JOINT PER STANDARD 606001 WITH DRILLED & GROUTED 24" LONG TIE BARS
 - (C) SAWED TRANSVERSE CONTRACTION JOINT PER STANDARD 420001 WITH HOT POUR SEAL
 - (EX) TRANSVERSE EXPANSION JOINT PER STANDARD 420001
 - (GR) NO BARS, KEYED LONGITUDINAL CONSTRUCTION JOINT WITH ALL KEYS FACING ONE DIRECTION ALONG INSIDE EDGE OF RAMP PAVEMENT AND SURROUNDING SHOULDER GORE
 - (F) LONGITUDINAL CONSTRUCTION JOINT WITH DRILLED & GROUTED #8 DEFORMED EPOXY COATED TIE BARS, 24" LONG AT 24" C-C
 - (J) LONGITUDINAL SAWED JOINT PER STANDARD 420001.
 - (SL) LONGITUDINAL CONSTRUCTION JOINT PER STANDARD 483001 EXCEPT FOR DRILLED & GROUTED 30" LONG #8 TIE BARS
 - (ST) SAWED TRANSVERSE SHOULDER CONTRACTION JOINT PER STANDARD 483001 (MATCH RAMP PAVEMENT JOINTS IN GORE AREAS)
 - SPACED 15' C-C ALONG OUTSIDE SHOULDER
 - SPACED 20' C-C AT ALL OTHER LOCATIONS

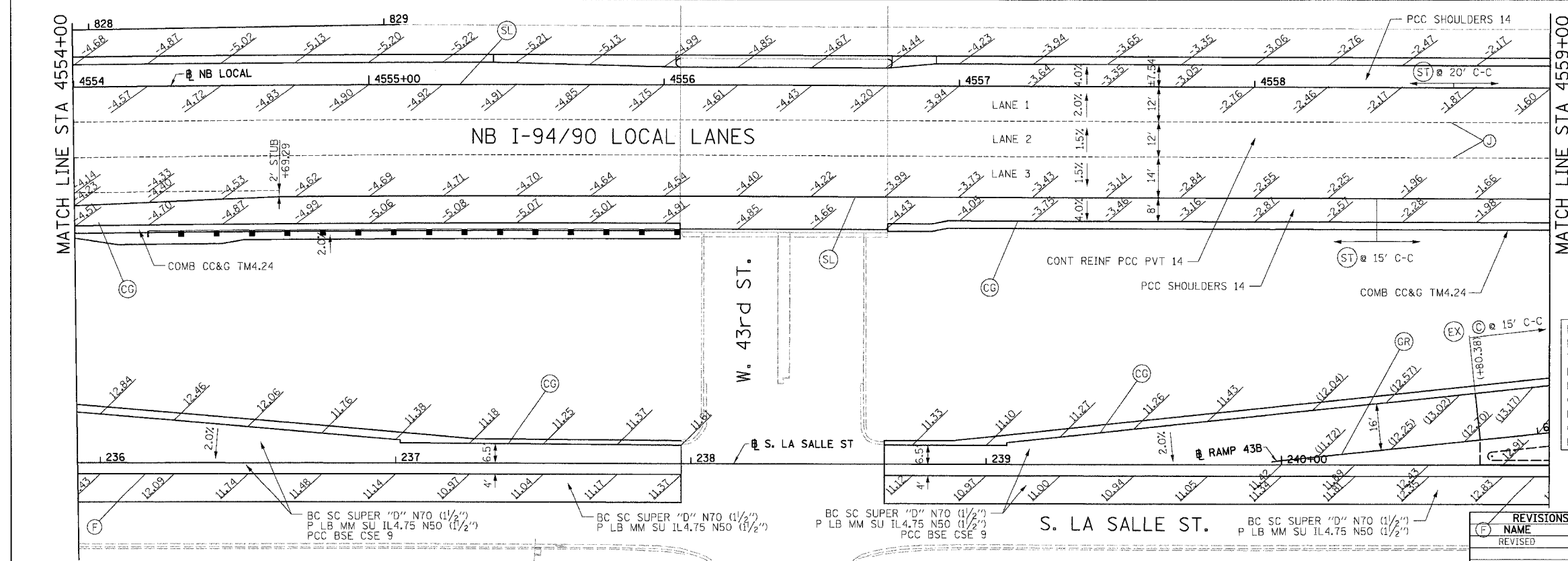
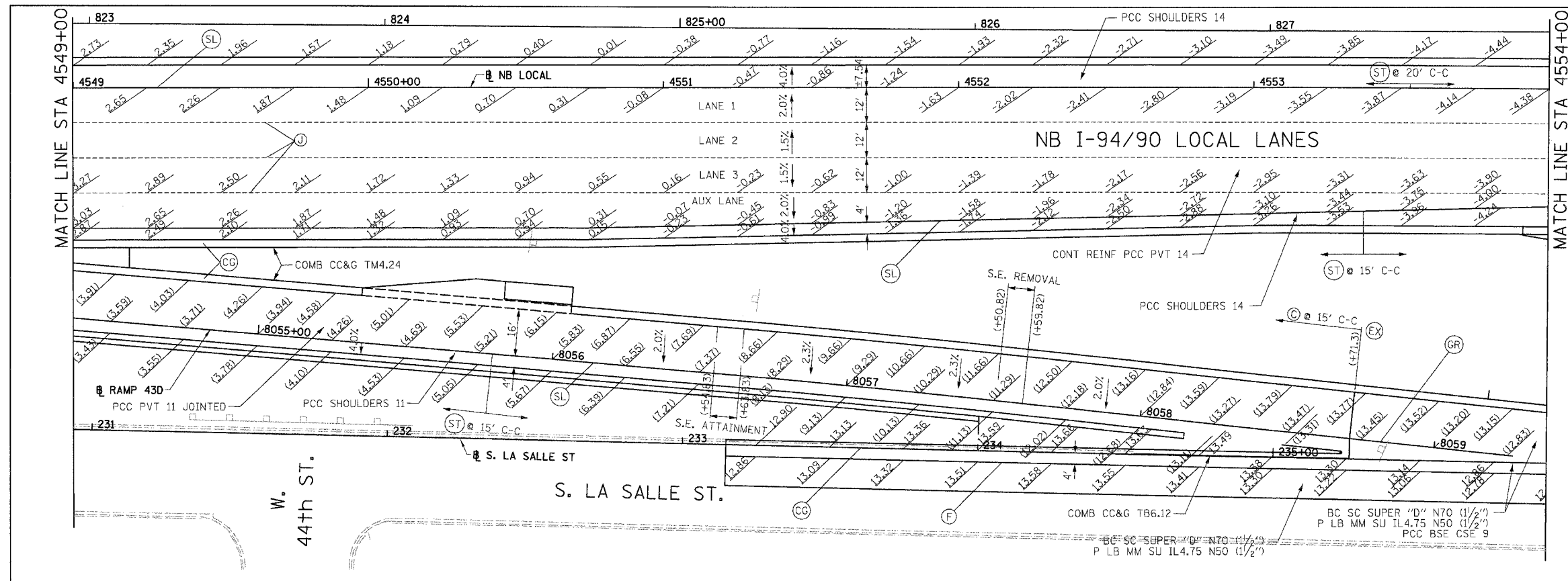

FOR PARTIAL WIDTH FRONTAGE ROAD IMPROVEMENTS, EITHER MATCH TRANSVERSE JOINT SPACING OF EXISTING PAVEMENT WITH NEWLY INSTALLED TRANSVERSE JOINTS OR PLACE NEWLY INSTALLED TRANSVERSE JOINTS AT 15'-0" INTERVALS. PLACE NEWLY INSTALLED TRANSVERSE JOINTS AT THE GREATER OF THESE TWO INTERVALS. SEE DETAIL SHEETS RDT-18A AND RDT-18B FOR PCC BASE COURSE JOINT DETAILS. (INCLUDED IN THE COST OF PORTLAND CEMENT CONCRETE BASE COURSE 9")

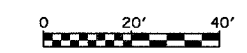

JE-9

NOTES:

1. (***) ELEVATION STATIONED OFF OF NB I-94/90 LOCAL LANES OR S. LA SALLE ST.
2. (***) ELEVATION STATIONED OFF OF RAMP ALIGNMENT
3. SEE ALIGNMENT AND TIES SHEETS FOR CURVE INFORMATION
4. SEE ROADWAY PLAN SHEETS FOR BEGINNING AND END TAPER STATIONS AND TAPER RATES.
5. PAVEMENT ELEVATIONS ALONG EDGE OF PAVEMENTS, EDGE OF SHOULDERS, GORES, RAMP AND IN AREAS OF SUPERELEVATION TRANSITION ARE PROVIDED AT 25' INTERVALS, FOR ALL ELEVATIONS, REFER TO THE PROFILES AND TYPICAL SECTIONS.
6. SEE ROADWAY DETAIL RDT-8 FOR THE TYING OF THE MEDIAN BARRIER BASE TO THE PCC SHOULDER.

BOWMAN, BARRETT & ASSOCIATES INC.
CONSULTING ENGINEERS
Chicago, Illinois
312.228.0100
www.bbainc.com

REVISIONS		DATE
NO.	NAME	
1	REVISED	6/23/06

ILLINOIS DEPARTMENT OF TRANSPORTATION
F.A.I. 94/90 (DAN RYAN EXPRESSWAY)
GARFIELD BLVD TO 31ST STREET (NB LOCAL LANES)
PAVEMENT JOINTING
AND ELEVATION PLANS
SCALE: 1"=20'
DATE: 06/09/06
DRAWN BY: JDC
CHECKED BY: RS

04/23/2006

F.A.I.	SECTION	COUNTY	TOTAL SHEETS	SHEET NO.
94/90	COOK		565	216
STA.	TO STA.			
FED. ROAD DIST. NO. ILLINOIS FED. AID PROJECT				
62301 • (2021-922 PT2 ETC 2324.6-1P) R-10				

- LEGEND:**
- (CG) LONGITUDINAL CONSTRUCTION JOINT PER STANDARD 606001 WITH DRILLED & GROUTED 24" LONG TIE BARS
 - (C) SAWED TRANSVERSE CONTRACTION JOINT PER STANDARD 420001 WITH HOT POUR SEAL
 - (EX) TRANSVERSE EXPANSION JOINT PER STANDARD 420001
 - (GR) NO BARS, KEYED LONGITUDINAL CONSTRUCTION JOINT WITH ALL KEYS FACING ONE DIRECTION ALONG INSIDE EDGE OF RAMP PAVEMENT AND SURROUNDING SHOULDER GORE
 - (F) LONGITUDINAL CONSTRUCTION JOINT WITH DRILLED & GROUTED #8 DEFORMED EPOXY COATED TIE BARS, 24" LONG AT 24" C-C
 - (J) LONGITUDINAL SAWED JOINT PER STANDARD 420001.
 - (SL) LONGITUDINAL CONSTRUCTION JOINT PER STANDARD 483001 EXCEPT FOR DRILLED & GROUTED 30" LONG #8 TIE BARS
 - (ST) SAWED TRANSVERSE SHOULDER CONTRACTION JOINT PER STANDARD 483001 (MATCH RAMP PAVEMENT JOINTS IN GORE AREAS)
 - SPACED 15' C-C ALONG OUTSIDE SHOULDER
 - SPACED 20' C-C AT ALL OTHER LOCATIONS

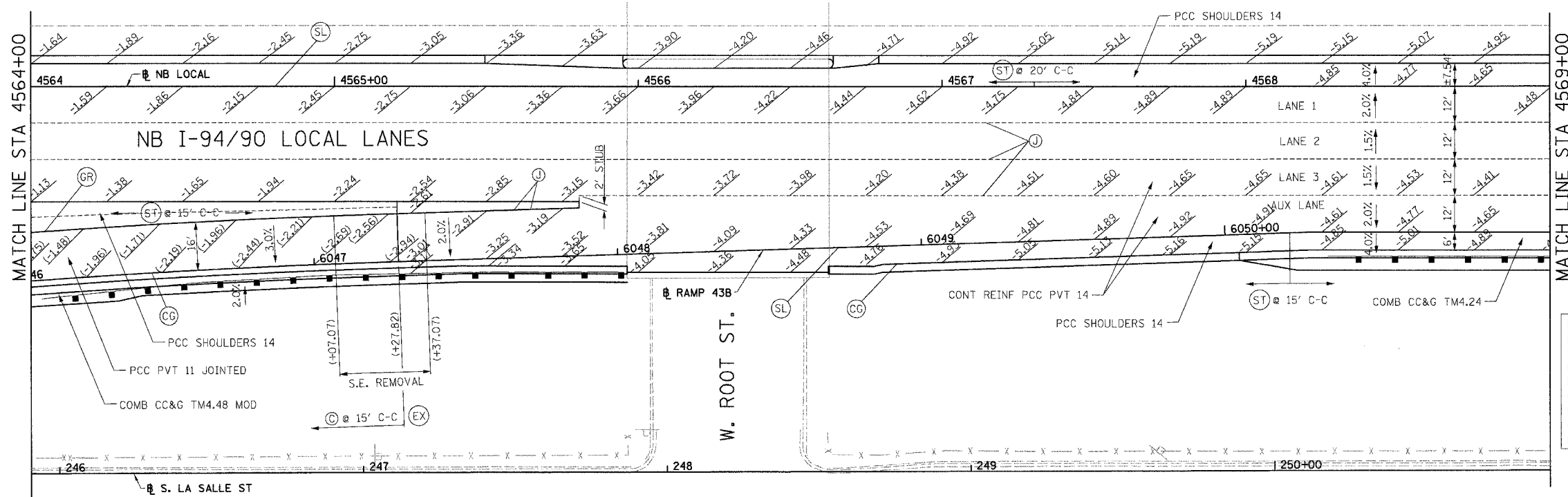
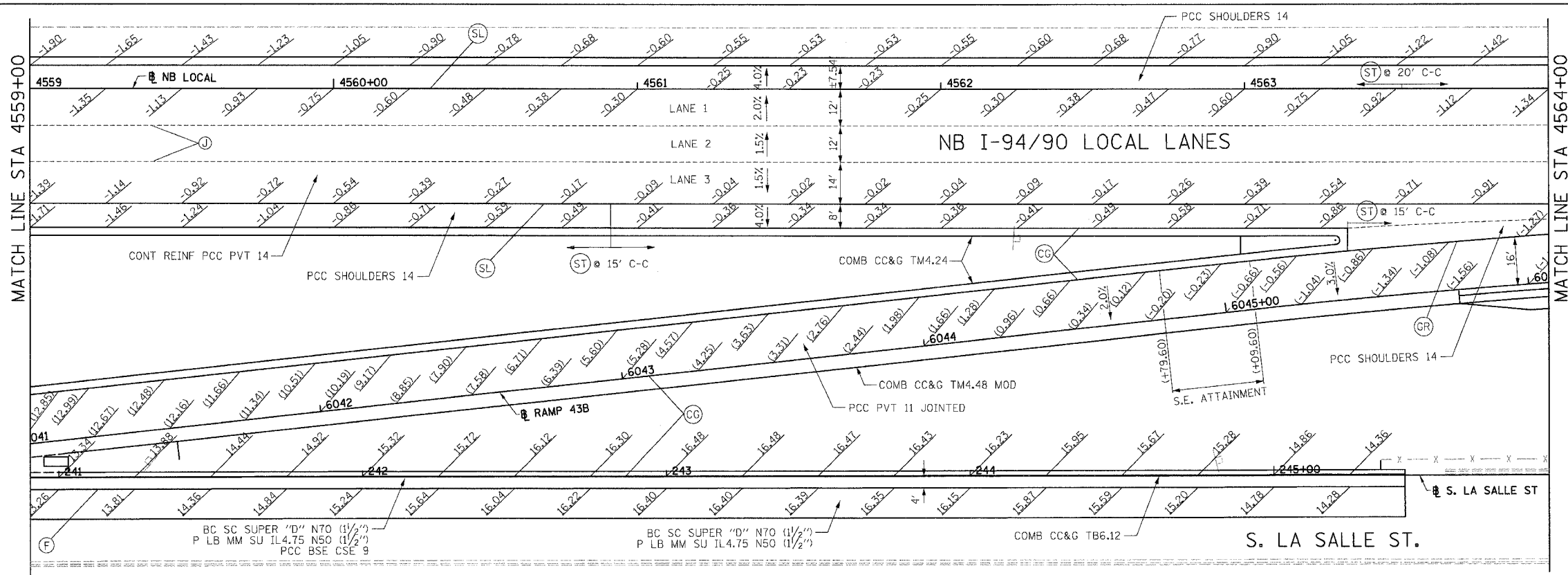

FOR PARTIAL WIDTH FRONTAGE ROAD IMPROVEMENTS, EITHER MATCH TRANSVERSE JOINT SPACING OF EXISTING PAVEMENT WITH NEWLY INSTALLED TRANSVERSE JOINTS OR PLACE NEWLY INSTALLED TRANSVERSE JOINTS AT 15'-0" INTERVALS. PLACE NEWLY INSTALLED TRANSVERSE JOINTS AT THE GREATER OF THESE TWO INTERVALS. SEE DETAIL SHEETS RDT-18A AND RDT-18B FOR PCC BASE COURSE JOINT DETAILS. (INCLUDED IN THE COST OF PORTLAND CEMENT CONCRETE BASE COURSE 9')

- NOTES:**
1. (***) ELEVATION STATIONED OFF OF NB I-94/90 LOCAL LANES OR LA SALLE ST.
 2. (****) ELEVATION STATIONED OFF OF RAMP ALIGNMENT
 3. SEE ALIGNMENT AND TIES SHEETS FOR CURVE INFORMATION
 4. SEE ROADWAY PLAN SHEETS FOR BEGINNING AND END TAPER STATIONS AND TAPER RATES.
 5. PAVEMENT ELEVATIONS ALONG EDGE OF PAVEMENTS, EDGE OF SHOULDERS, GORES, RAMPS AND IN AREAS OF SUPERELEVATION TRANSITION ARE PROVIDED AT 25' INTERVALS, FOR ALL ELEVATIONS, REFER TO THE PROFILES AND TYPICAL SECTIONS.
 6. SEE ROADWAY DETAIL RDT-8 FOR THE TYING OF THE MEDIAN BARRIER BASE TO THE PCC SHOULDER.

BOWMAN, BARRETT & ASSOCIATES INC.
CONSULTING ENGINEERS
Chicago, Illinois
312.228.0100
www.bbainc.com

REVISIONS	
NAME	DATE
REVISED	6/23/06

0 20' 40'

ILLINOIS DEPARTMENT OF TRANSPORTATION
F.A.I. 94/90 (DAN RYAN EXPRESSWAY)
GARFIELD BLVD TO 31ST STREET (NB LOCAL LANES)
PAVEMENT JOINTING
AND ELEVATION PLANS

SCALE: 1"=20'
DATE: 06/09/06

DRAWN BY: JDC
CHECKED BY: RS

JE-10

6/23/2006

F.A.I.	SECTION	COUNTY	TOTAL SHEETS	SHEET NO.
94/90		COOK	565	217
STA.	TO STA.			
FED. ROAD DIST. NO.	ILLINOIS	FED. AID PROJECT		
62301		(2021-922 PT2 ETC 2324.6-1P) R-10		

- LEGEND:**
- (CG) LONGITUDINAL CONSTRUCTION JOINT PER STANDARD 606001 WITH DRILLED & GROUTED 24" LONG TIE BARS
 - (C) SAWED TRANSVERSE CONTRACTION JOINT PER STANDARD 420001 WITH HOT POUR SEAL
 - (EX) TRANSVERSE EXPANSION JOINT PER STANDARD 420001
 - (GR) NO BARS, KEYED LONGITUDINAL CONSTRUCTION JOINT WITH ALL KEYS FACING ONE DIRECTION ALONG INSIDE EDGE OF RAMP PAVEMENT AND SURROUNDING SHOULDER GORE
 - (F) LONGITUDINAL CONSTRUCTION JOINT WITH DRILLED & GROUTED #8 DEFORMED EPOXY COATED TIE BARS, 24" LONG AT 24" C-C
 - (J) LONGITUDINAL SAWED JOINT PER STANDARD 420001.
 - (SL) LONGITUDINAL CONSTRUCTION JOINT PER STANDARD 420001 EXCEPT FOR DRILLED & GROUTED 24" LONG #8 TIE BARS. SEAL PER ASTM D 3405
 - (ST) LONGITUDINAL CONSTRUCTION JOINT PER STANDARD 483001 EXCEPT FOR DRILLED & GROUTED 30" LONG #8 TIE BARS
 - (ST) SAWED TRANSVERSE SHOULDER CONTRACTION JOINT PER STANDARD 483001 (MATCH RAMP PAVEMENT JOINTS IN GORE AREAS)
 - SPACED 15" C-C ALONG OUTSIDE SHOULDER
 - SPACED 20" C-C AT ALL OTHER LOCATIONS

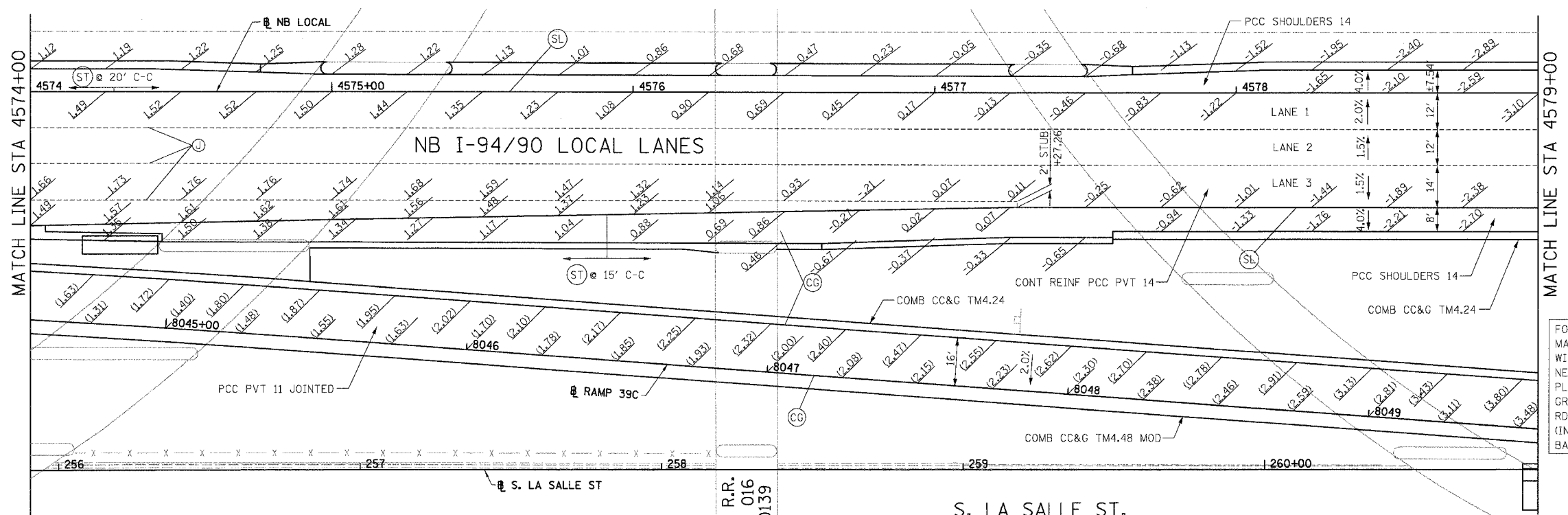
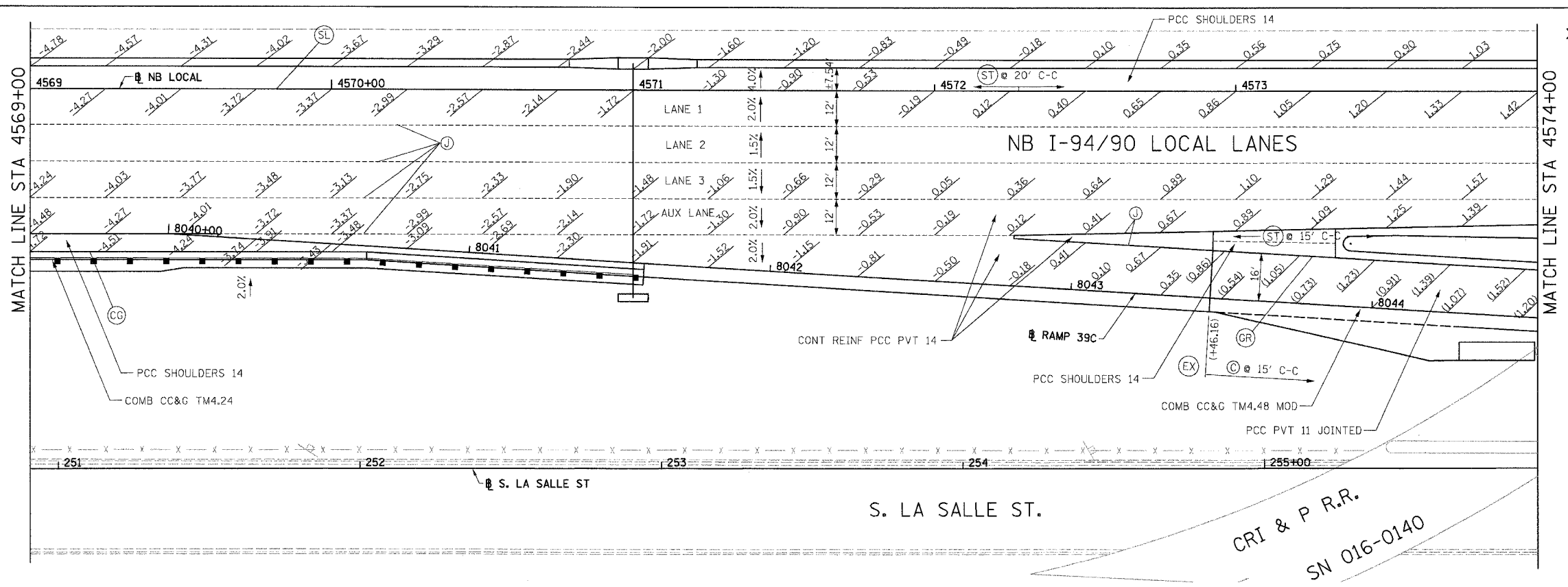

SWALE ELEVATIONS		
STA	OFFSET	ELEVATION
4572+92		
4573+00		
+25		
+51		

FOR PARTIAL WIDTH FRONTAGE ROAD IMPROVEMENTS, EITHER MATCH TRANSVERSE JOINT SPACING OF EXISTING PAVEMENT WITH NEWLY INSTALLED TRANSVERSE JOINTS OR PLACE NEWLY INSTALLED TRANSVERSE JOINTS AT 15'-0" INTERVALS. PLACE NEWLY INSTALLED TRANSVERSE JOINTS AT THE GREATER OF THESE TWO INTERVALS. SEE DETAIL SHEETS RDT-18A AND RDT-18B FOR PCC BASE COURSE JOINT DETAILS. (INCLUDED IN THE COST OF PORTLAND CEMENT CONCRETE BASE COURSE 9")

- NOTES:**
- *.** ELEVATION STATIONED OFF OF NB I-94/90 LOCAL LANES OR S. LA SALLE ST.
 - (***) ELEVATION STATIONED OFF OF RAMP ALIGNMENT
 - SEE ALIGNMENT AND TIES SHEETS FOR CURVE INFORMATION
 - SEE ROADWAY PLAN SHEETS FOR BEGINNING AND END TAPER STATIONS AND TAPER RATES.
 - PAVEMENT ELEVATIONS ALONG EDGE OF PAVEMENTS, EDGE OF SHOULDERS, GORES, RAMPS AND IN AREAS OF SUPERELEVATION TRANSITION ARE PROVIDED AT 25' INTERVALS. FOR ALL ELEVATIONS, REFER TO THE PROFILES AND TYPICAL SECTIONS.
 - SEE ROADWAY DETAIL RDT-8 FOR THE TYING OF THE MEDIAN BARRIER BASE TO THE PCC SHOULDER.

BOWMAN, BARRETT & ASSOCIATES INC.
CONSULTING ENGINEERS
Chicago, Illinois
312.228.0100
www.bbainc.com

REVISIONS	
NAME	DATE
REVISED	6/23/06

ILLINOIS DEPARTMENT OF TRANSPORTATION
F.A.I. 94/90 (DAN RYAN EXPRESSWAY)
GARFIELD BLVD TO 31ST STREET (NB LOCAL LANES)
PAVEMENT JOINTING
AND ELEVATION PLANS

SCALE: 1"=20'
DATE: 06/09/06

DRAWN BY: JDC
CHECKED BY: RS

6/23/2006 10:46:36 AM

F.A.I.	SECTION	COUNTY	TOTAL SHEETS	SHEET NO.
94/90		COOK	565	218
STA.	TO STA.			
FED. ROAD DIST. NO.	ILLINOIS	FED. AID PROJECT		
62301		(2021-922 PT2 ETC 2324.6-1P) R-10		

- LEGEND:**
- (CG) LONGITUDINAL CONSTRUCTION JOINT PER STANDARD 606001 WITH DRILLED & GROUTED 24" LONG TIE BARS
 - (C) SAWED TRANSVERSE CONTRACTION JOINT PER STANDARD 420001 WITH HOT POUR SEAL
 - (EX) TRANSVERSE EXPANSION JOINT PER STANDARD 420001
 - (GR) NO BARS, KEYED LONGITUDINAL CONSTRUCTION JOINT WITH ALL KEYS FACING ONE DIRECTION ALONG INSIDE EDGE OF RAMP PAVEMENT AND SURROUNDING SHOULDER GORE
 - (F) LONGITUDINAL CONSTRUCTION JOINT WITH DRILLED & GROUTED #8 DEFORMED EPOXY COATED TIE BARS, 24" LONG AT 24" C-C
 - (J) LONGITUDINAL SAWED JOINT PER STANDARD 420001.
 - (SL) LONGITUDINAL CONSTRUCTION JOINT PER STANDARD 483001 EXCEPT FOR DRILLED & GROUTED 30" LONG #8 TIE BARS
 - (ST) SAWED TRANSVERSE SHOULDER CONTRACTION JOINT PER STANDARD 483001 (MATCH RAMP PAVEMENT JOINTS IN GORE AREAS)
 - SPACED 15' C-C ALONG OUTSIDE SHOULDER
 - SPACED 20' C-C AT ALL OTHER LOCATIONS

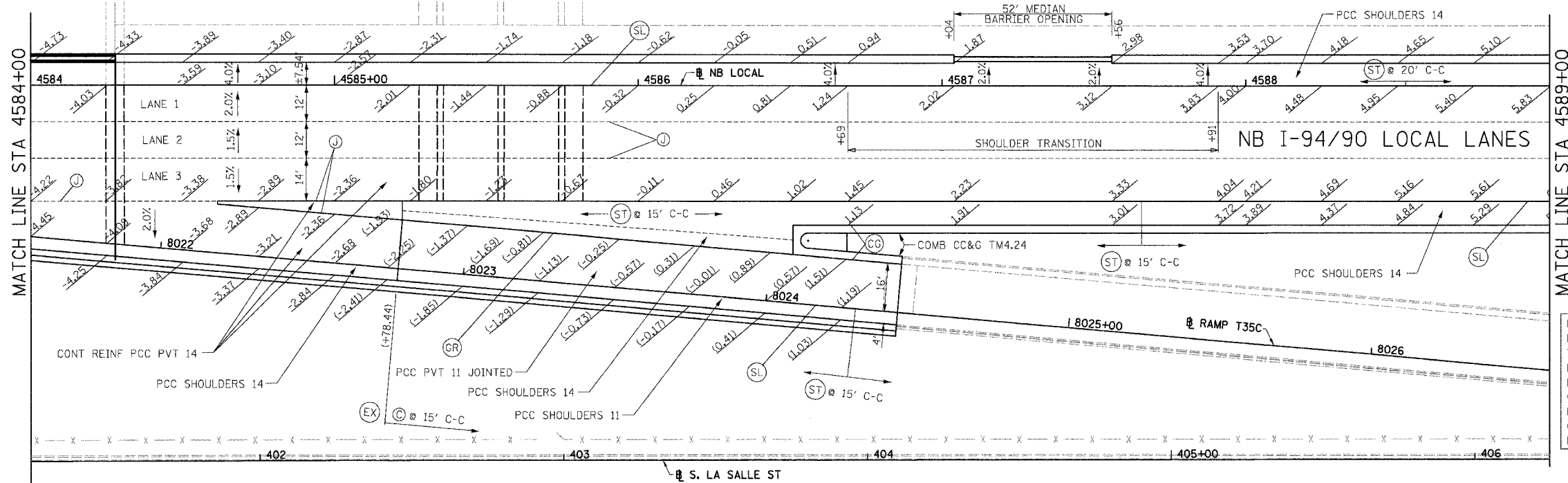
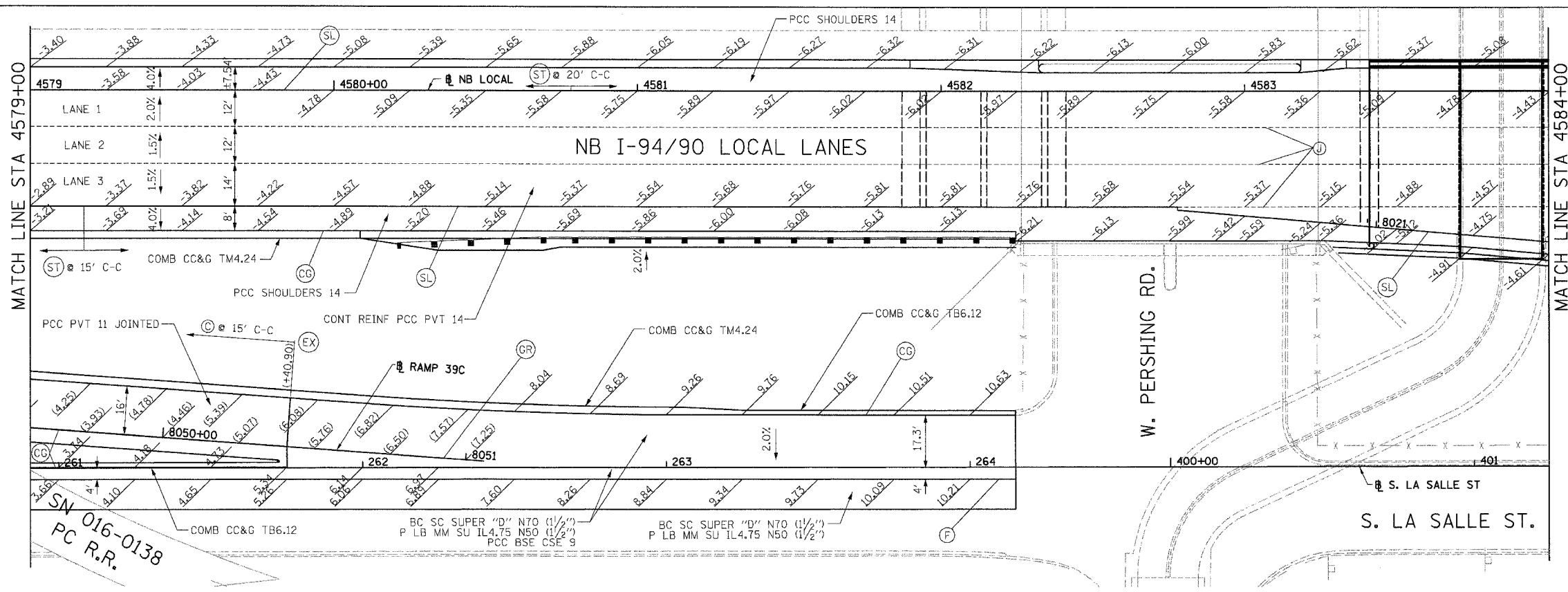

SWALE ELEVATIONS		
STA	OFFSET	ELEVATION
4585+22		
+50		
+75		
4586+00		
+25		
+51		

FOR PARTIAL WIDTH FRONTAGE ROAD IMPROVEMENTS, EITHER MATCH TRANSVERSE JOINT SPACING OF EXISTING PAVEMENT WITH NEWLY INSTALLED TRANSVERSE JOINTS OR PLACE NEWLY INSTALLED TRANSVERSE JOINTS AT 15'-0" INTERVALS. PLACE NEWLY INSTALLED TRANSVERSE JOINTS AT THE GREATER OF THESE TWO INTERVALS. SEE DETAIL SHEETS RDT-18A AND RDT-18B FOR PCC BASE COURSE JOINT DETAILS. (INCLUDED IN THE COST OF PORTLAND CEMENT CONCRETE BASE COURSE 9")

- NOTES:**
- ELEVATION STATIONED OFF OF NB I-94/90 LOCAL LANES OR S. LA SALLE ST.
 - ELEVATION STATIONED OFF OF RAMP ALIGNMENT
 - SEE ALIGNMENT AND TIES SHEETS FOR CURVE INFORMATION
 - SEE ROADWAY PLAN SHEETS FOR BEGINNING AND END TAPER STATIONS AND TAPER RATES.
 - PAVEMENT ELEVATIONS ALONG EDGE OF PAVEMENTS, EDGE OF SHOULDERS, GORES, RAMPS AND IN AREAS OF SUPERELEVATION TRANSITION ARE PROVIDED AT 25' INTERVALS, FOR ALL ELEVATIONS, REFER TO THE PROFILES AND TYPICAL SECTIONS.
 - SEE ROADWAY DETAIL RDT-8 FOR THE TYING OF THE MEDIAN BARRIER BASE TO THE PCC SHOULDER.

BOWMAN, BARRETT & ASSOCIATES INC.
CONSULTING ENGINEERS
Chicago, Illinois
312.228.0100
www.bbainc.com

REVISIONS	
NAME	DATE
REVISED	6/23/06

ILLINOIS DEPARTMENT OF TRANSPORTATION
F.A.I. 94/90 (DAN RYAN EXPRESSWAY)
GARFIELD BLVD TO 31ST STREET (NB LOCAL LANES)
PAVEMENT JOINTING
AND ELEVATION PLANS

SCALE: 1"=20'
DATE: 06/09/06

DRAWN BY: JDC
CHECKED BY: RS

6/23/2006 10:46:59 AM

F.A.I.	SECTION	COUNTY	TOTAL SHEETS	SHEET NO.
94/90		COOK	565	220
STA.	TO STA.			
FED. ROAD DIST. NO.	ILLINOIS	FED. AID PROJECT		
62301	• (2021-922 PT2 ETC 2324.6-1P) R-10			

- LEGEND:
- (CG) LONGITUDINAL CONSTRUCTION JOINT PER STANDARD 606001 WITH DRILLED & GROUTED 24" LONG TIE BARS
 - (C) SAWED TRANSVERSE CONTRACTION JOINT PER STANDARD 420001 WITH HOT POUR SEAL
 - (EX) TRANSVERSE EXPANSION JOINT PER STANDARD 420001
 - (GR) NO BARS, KEYED LONGITUDINAL CONSTRUCTION JOINT WITH ALL KEYS FACING ONE DIRECTION ALONG INSIDE EDGE OF RAMP PAVEMENT AND SURROUNDING SHOULDER GORE
 - (F) LONGITUDINAL CONSTRUCTION JOINT WITH DRILLED & GROUTED #8 DEFORMED EPOXY COATED TIE BARS, 24" LONG AT 24" C-C
 - (J) LONGITUDINAL SAWED JOINT PER STANDARD 420001.
 - (SL) LONGITUDINAL CONSTRUCTION JOINT PER STANDARD 420001 EXCEPT FOR DRILLED & GROUTED 24" LONG #8 TIE BARS. SEAL PER ASTM D 3405
 - (ST) LONGITUDINAL CONSTRUCTION JOINT PER STANDARD 483001 EXCEPT FOR DRILLED & GROUTED 30" LONG #8 TIE BARS
 - (ST) SAWED TRANSVERSE SHOULDER CONTRACTION JOINT PER STANDARD 483001 (MATCH RAMP PAVEMENT JOINTS IN GORE AREAS)
 - SPACED 15' C-C ALONG OUTSIDE SHOULDER
 - SPACED 20' C-C AT ALL OTHER LOCATIONS

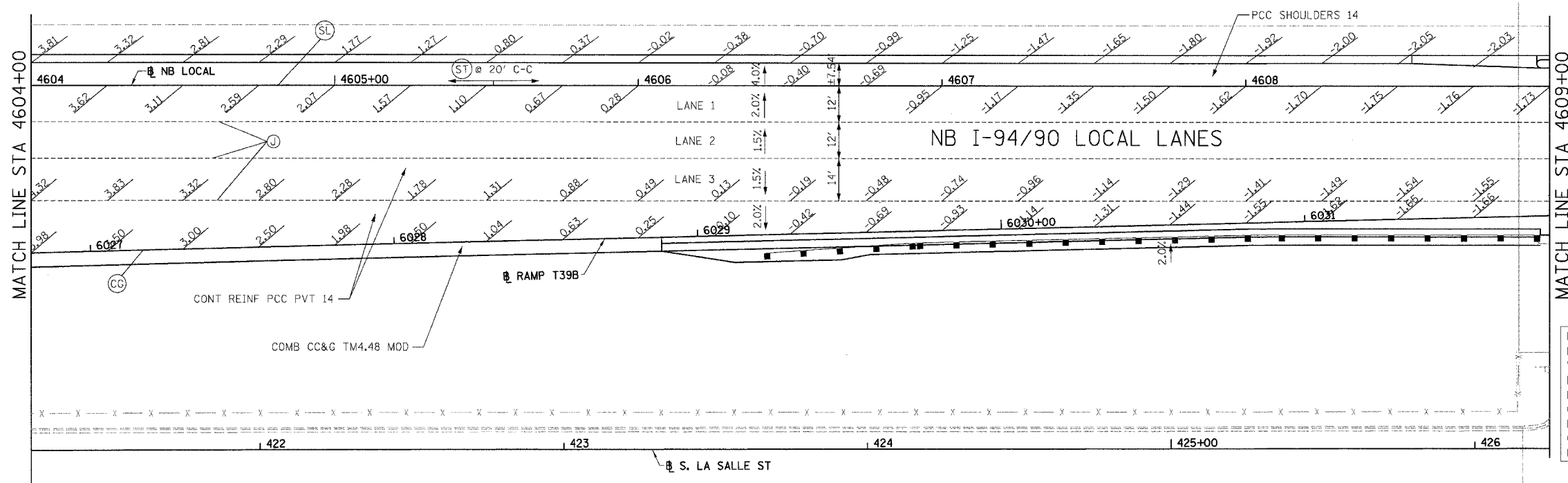
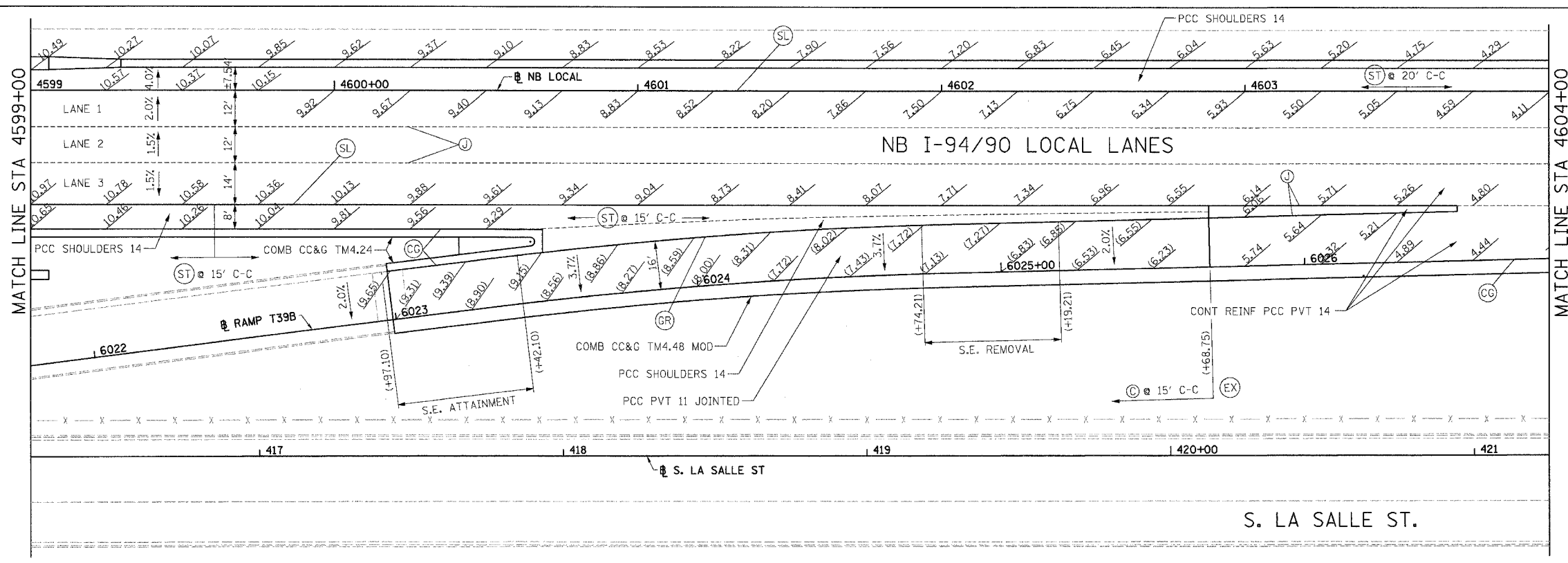

FOR PARTIAL WIDTH FRONTAGE ROAD IMPROVEMENTS, EITHER MATCH TRANSVERSE JOINT SPACING OF EXISTING PAVEMENT WITH NEWLY INSTALLED TRANSVERSE JOINTS OR PLACE NEWLY INSTALLED TRANSVERSE JOINTS AT 15'-0" INTERVALS. PLACE NEWLY INSTALLED TRANSVERSE JOINTS AT THE GREATER OF THESE TWO INTERVALS. SEE DETAIL SHEETS RDT-18A AND RDT-18B FOR PCC BASE COURSE JOINT DETAILS. (INCLUDED IN THE COST OF PORTLAND CEMENT CONCRETE BASE COURSE 9")

- NOTES:
- *** ELEVATION STATIONED OFF OF NB I-94/90 LOCAL LANES OR S. LA SALLE ST.
 - (***) ELEVATION STATIONED OFF OF RAMP ALIGNMENT
 - SEE ALIGNMENT AND TIES SHEETS FOR CURVE INFORMATION
 - SEE ROADWAY PLAN SHEETS FOR BEGINNING AND END TAPER STATIONS AND TAPER RATES.
 - PAVEMENT ELEVATIONS ALONG EDGE OF PAVEMENTS, EDGE OF SHOULDERS, GORES, RAMP AND IN AREAS OF SUPERELEVATION TRANSITION ARE PROVIDED AT 25' INTERVALS, FOR ALL ELEVATIONS, REFER TO THE PROFILES AND TYPICAL SECTIONS.
 - SEE ROADWAY DETAIL RDT-8 FOR THE TYING OF THE MEDIAN BARRIER BASE TO THE PCC SHOULDER.

BOWMAN, BARRETT & ASSOCIATES INC.
CONSULTING ENGINEERS
Chicago, Illinois
312.228.0100
www.bbainc.com

REVISIONS	
NAME	DATE
REVISED	6/23/08

ILLINOIS DEPARTMENT OF TRANSPORTATION
F.A.I. 94/90 (DAN RYAN EXPRESSWAY)
GARFIELD BLVD TO 31ST STREET (NB LOCAL LANES)
PAVEMENT JOINTING
AND ELEVATION PLANS

SCALE: 1"=20'
DATE: 06/09/06

DRAWN BY: JDC
CHECKED BY: RS

6/23/2008 10:54:46 AM

F.A.I.	SECTION	COUNTY	TOTAL SHEETS	SHEET NO.
94/90		COOK	565	221
STA.	TO STA.			
FED. ROAD DIST. NO.	ILLINOIS	FED. AID PROJECT		
62301	• (2021-922 PT2 ETC 2324.6-1P) R-10			

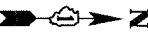

- LEGEND:
- (CG) LONGITUDINAL CONSTRUCTION JOINT PER STANDARD 606001 WITH DRILLED & GROUTED 24" LONG TIE BARS
 - (C) SAWED TRANSVERSE CONSTRUCTION JOINT PER STANDARD 420001 WITH HOT POUR SEAL
 - (EX) TRANSVERSE EXPANSION JOINT PER STANDARD 420001
 - (GR) NO BARS, KEYED LONGITUDINAL CONSTRUCTION JOINT WITH ALL KEYS FACING ONE DIRECTION ALONG INSIDE EDGE OF RAMP PAVEMENT AND SURROUNDING SHOULDER GORE
 - (F) LONGITUDINAL CONSTRUCTION JOINT WITH DRILLED & GROUTED #8 DEFORMED EPOXY COATED TIE BARS, 24" LONG AT 24" C-C
 - (J) LONGITUDINAL SAWED JOINT PER STANDARD 420001
 - (SL) LONGITUDINAL CONSTRUCTION JOINT PER STANDARD 483001 EXCEPT FOR DRILLED & GROUTED 30" LONG #8 TIE BARS
 - (ST) SAWED TRANSVERSE SHOULDER CONTRACTION JOINT PER STANDARD 483001 (MATCH RAMP PAVEMENT JOINTS IN GORE AREAS)
 - SPACED 15' C-C ALONG OUTSIDE SHOULDER
 - SPACED 20' C-C AT ALL OTHER LOCATIONS

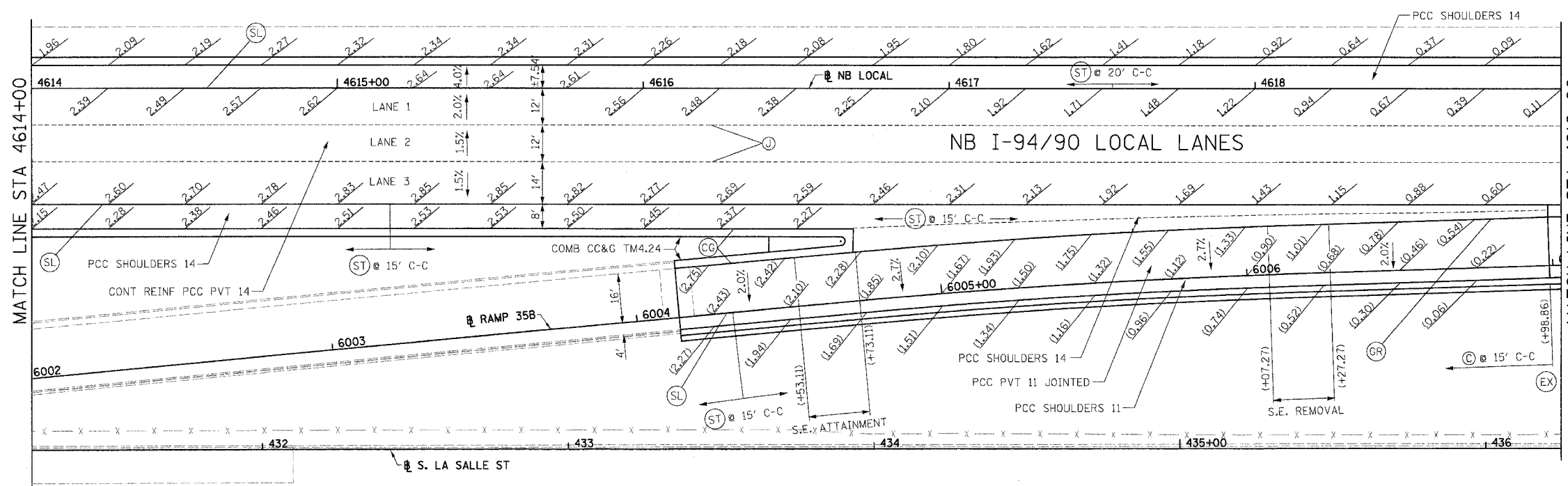
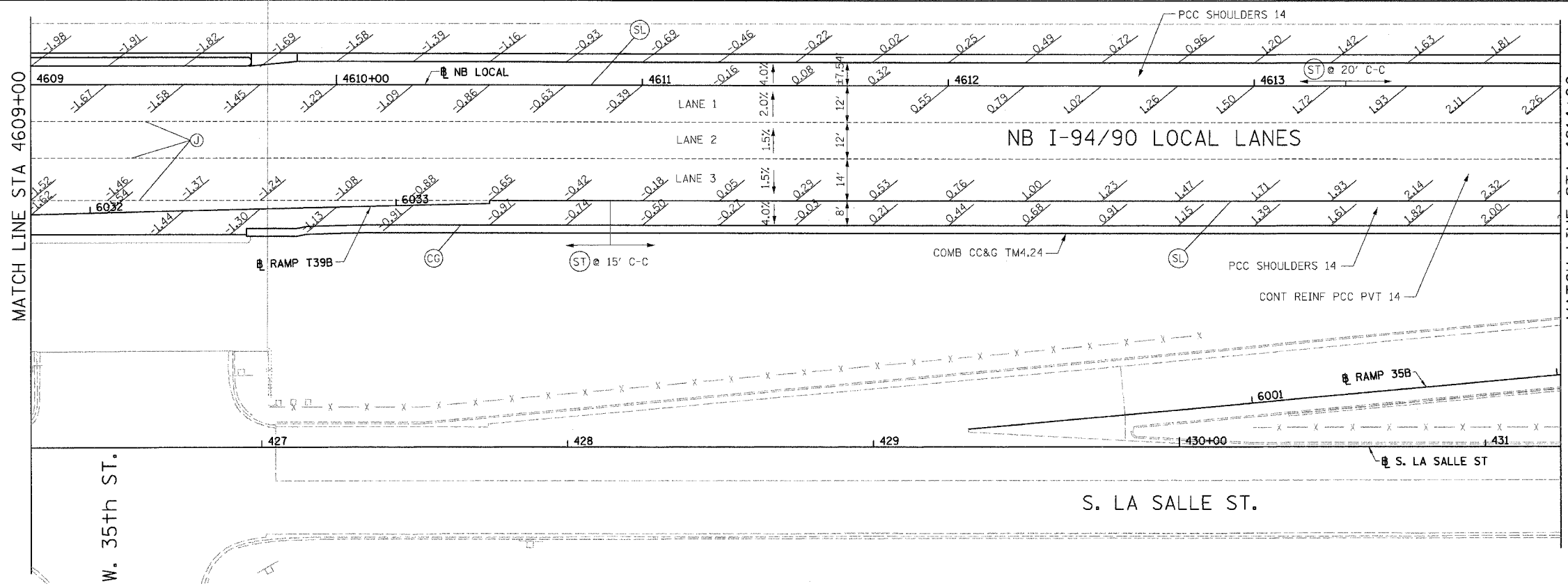

FOR PARTIAL WIDTH FRONTAGE ROAD IMPROVEMENTS, EITHER MATCH TRANSVERSE JOINT SPACING OF EXISTING PAVEMENT WITH NEWLY INSTALLED TRANSVERSE JOINTS OR PLACE NEWLY INSTALLED TRANSVERSE JOINTS AT 15'-0" INTERVALS. PLACE NEWLY INSTALLED TRANSVERSE JOINTS AT THE GREATER OF THESE TWO INTERVALS. SEE DETAIL SHEETS RDT-18A AND RDT-18B FOR PCC BASE COURSE JOINT DETAILS. (INCLUDED IN THE COST OF PORTLAND CEMENT CONCRETE BASE COURSE 9")

NOTES:

1. ELEVATION STATIONED OFF OF NB I-94/90 LOCAL LANES OR S. LA SALLE ST.
2. (•••) ELEVATION STATIONED OFF OF RAMP ALIGNMENT
3. SEE ALIGNMENT AND TIES SHEETS FOR CURVE INFORMATION
4. SEE ROADWAY PLAN SHEETS FOR BEGINNING AND END TAPER STATIONS AND TAPER RATES.
5. PAVEMENT ELEVATIONS ALONG EDGE OF PAVEMENTS, EDGE OF SHOULDERS, GORES, RAMPS AND IN AREAS OF SUPERELEVATION TRANSITION ARE PROVIDED AT 25' INTERVALS, FOR ALL ELEVATIONS, REFER TO THE PROFILES AND TYPICAL SECTIONS.
6. SEE ROADWAY DETAIL RDT-8 FOR THE TYING OF THE MEDIAN BARRIER BASE TO THE PCC SHOULDER.

BOWMAN, BARRETT & ASSOCIATES INC.
CONSULTING ENGINEERS
Chicago, Illinois
312.228.0100
www.bbainc.com

REVISIONS	
NAME	DATE
REVISED	6/23/06



ILLINOIS DEPARTMENT OF TRANSPORTATION
F.A.I. 94/90 (DAN RYAN EXPRESSWAY)
GARFIELD BLVD TO 31ST STREET (NB LOCAL LANES)
PAVEMENT JOINTING
AND ELEVATION PLANS

SCALE: 1"=20'
DATE: 06/09/06

DRAWN BY: JDC
CHECKED BY: RS

6/23/2006 10:40:40 AM

F.A.I.	SECTION	COUNTY	TOTAL SHEETS	SHEET NO.
94/90		COOK	565	222
STA.	TO STA.			
FED. ROAD DIST. NO.	ILLINOIS	FED. AID PROJECT		
62301	(2021-922 PT2 ETC 2324.6-1P) R-10			

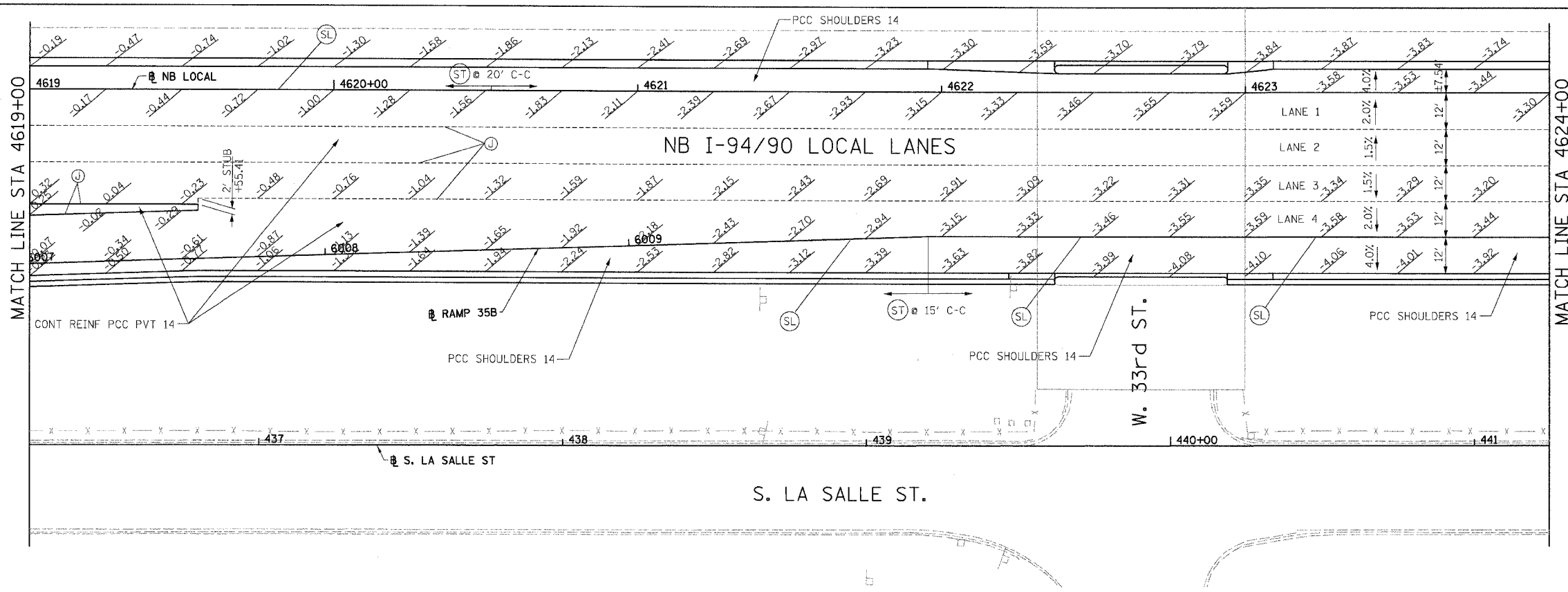

- LEGEND:
- (CG) LONGITUDINAL CONSTRUCTION JOINT PER STANDARD 606001 WITH DRILLED & GROUDED 24" LONG TIE BARS
 - (C) SAWED TRANSVERSE CONSTRUCTION JOINT PER STANDARD 420001 WITH HOT POUR SEAL
 - (EX) TRANSVERSE EXPANSION JOINT PER STANDARD 420001
 - (GR) NO BARS, KEYED LONGITUDINAL CONSTRUCTION JOINT WITH ALL KEYS FACING ONE DIRECTION ALONG INSIDE EDGE OF RAMP PAVEMENT AND SURROUNDING SHOULDER GORE
 - (F) LONGITUDINAL CONSTRUCTION JOINT WITH DRILLED & GROUDED #8 DEFORMED EPOXY COATED TIE BARS, 24" LONG AT 24" C-C
 - (J) LONGITUDINAL SAWED JOINT PER STANDARD 420001
 - (SL) LONGITUDINAL CONSTRUCTION JOINT PER STANDARD 483001 EXCEPT FOR DRILLED & GROUDED 30" LONG #8 TIE BARS
 - (ST) SAWED TRANSVERSE SHOULDER CONSTRUCTION JOINT PER STANDARD 483001 (MATCH RAMP PAVEMENT JOINTS IN GORE AREAS)
- LONGITUDINAL CONSTRUCTION JOINT PER STANDARD 420001 EXCEPT FOR DRILLED & GROUDED 24" LONG #8 TIE BARS. SEAL PER ASTM D 3405

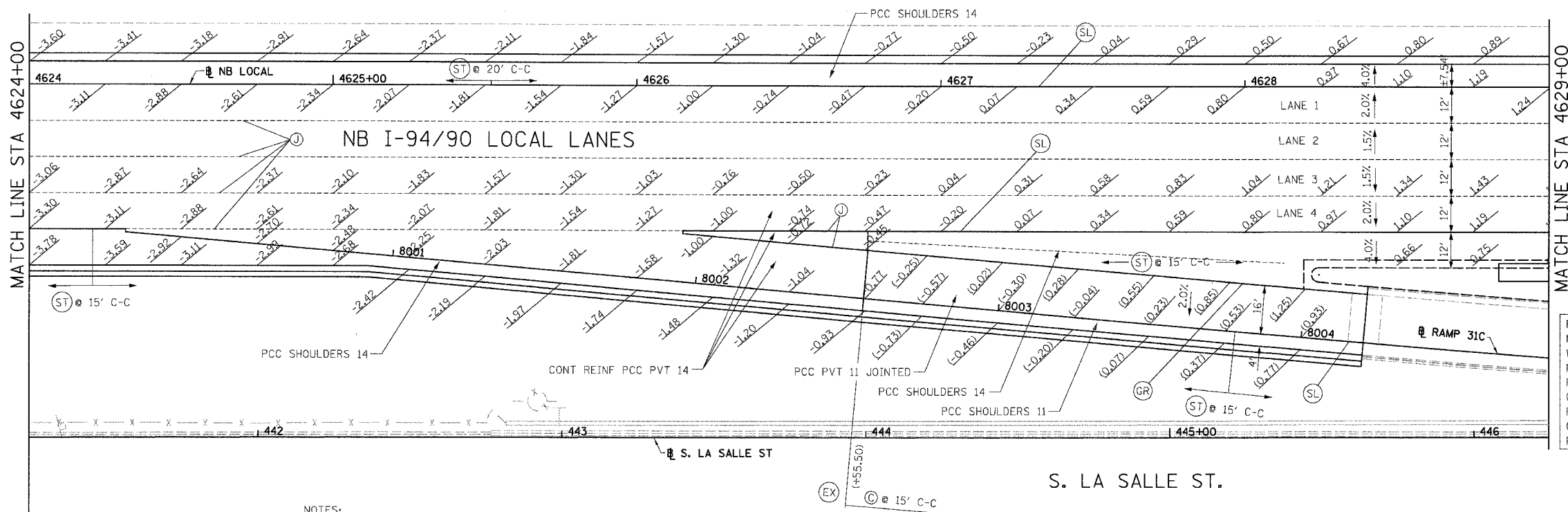

SWALE ELEVATIONS		
STA	OFFSET	ELEVATION
4626+76		
4627+00		
	+25	
	+50	
	+75	
4628+00		
	+11	

FOR PARTIAL WIDTH FRONTAGE ROAD IMPROVEMENTS, EITHER MATCH TRANSVERSE JOINT SPACING OF EXISTING PAVEMENT WITH NEWLY INSTALLED TRANSVERSE JOINTS OR PLACE NEWLY INSTALLED TRANSVERSE JOINTS AT 15'-0" INTERVALS. PLACE NEWLY INSTALLED TRANSVERSE JOINTS AT THE GREATER OF THESE TWO INTERVALS. SEE DETAIL SHEETS RDT-18A AND RDT-18B FOR PCC BASE COURSE JOINT DETAILS. (INCLUDED IN THE COST OF PORTLAND CEMENT CONCRETE BASE COURSE 9")

- NOTES:
- ELEVATION STATIONED OFF OF NB I-94/90 LOCAL LANES OR S. LA SALLE ST.
 - (*) ELEVATION STATIONED OFF OF RAMP ALIGNMENT.
 - SEE ALIGNMENT AND TIES SHEETS FOR LDRV INFORMATION.
 - SEE ROADWAY PLAN SHEETS FOR BEGINNING AND END TAPER STATIONS AND TAPER RATES.
 - PAVEMENT ELEVATIONS ALONG EDGE OF PAVEMENTS, EDGE OF SHOULDERS, GORES, RAMPS AND IN AREAS OF SUPERELEVATION TRANSITION ARE PROVIDED AT 25' INTERVALS. FOR ALL ELEVATIONS, REFER TO THE PROFILES AND TYPICAL SECTIONS.
 - SEE ROADWAY DETAIL RDT-8 FOR THE TYING OF THE MEDIAN BARRIER BASE TO THE PCC SHOULDER.

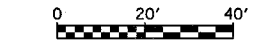

REVISIONS	
NAME	DATE

ILLINOIS DEPARTMENT OF TRANSPORTATION
 F.A.I. 94/90 (DAN RYAN EXPRESSWAY)
 GARFIELD BLVD TO 31ST STREET (NB LOCAL LANES)
 PAVEMENT JOINTING
 AND ELEVATION PLANS

SCALE: 1"=20'
 DATE: 06/09/06
 DRAWN BY: JDC
 CHECKED BY: RS

BOWMAN, BARRETT & ASSOCIATES INC.
 CONSULTING ENGINEERS
 Chicago, Illinois
 312.228.0100
 www.bbainc.com

12/4/05 5 PM 6/7/2006

F.A.I.	SECTION	COUNTY	TOTAL SHEETS	SHEET NO.
94/90	*	COOK	565	223
STA. 4629+00		TO STA. 4634+00		
FED. ROAD DIST. NO.		ILLINOIS FED. AID PROJECT		
62301		(2021-922 PT2 ETC 2324.6-1P) R-10		

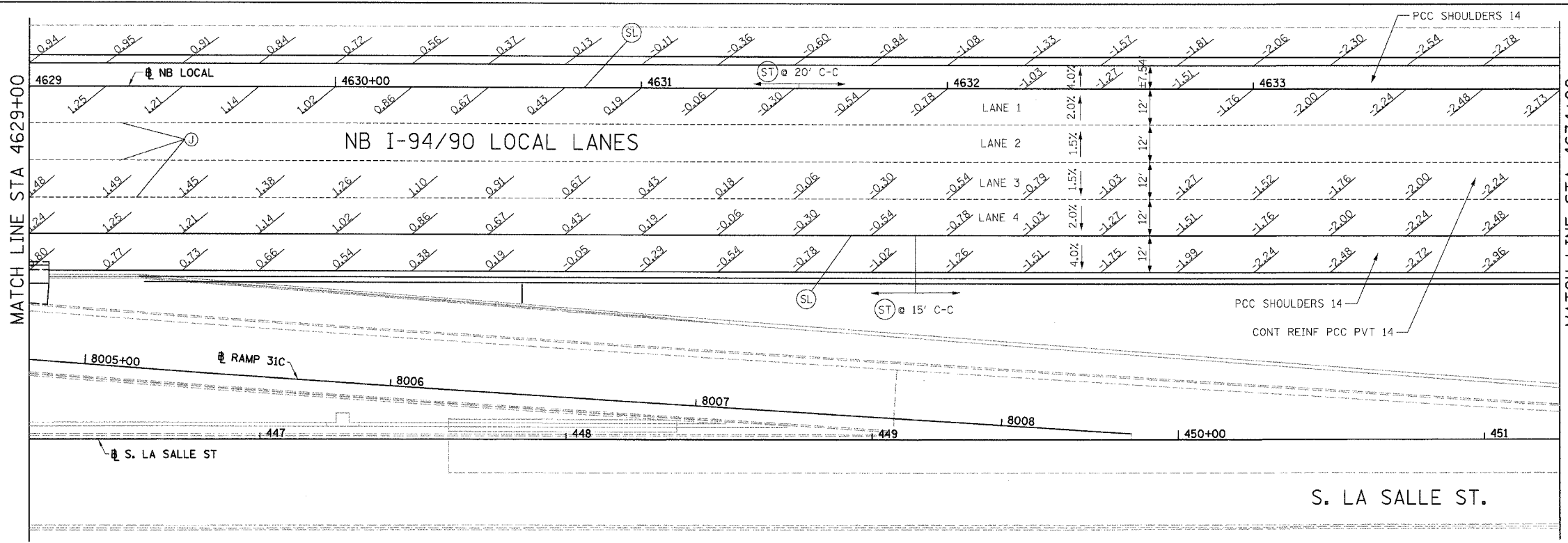

- LEGEND:
- (CG) LONGITUDINAL CONSTRUCTION JOINT PER STANDARD 606001 WITH DRILLED & GROUTED 24" LONG TIE BARS
 - (C) SAWED TRANSVERSE CONTRACTION JOINT PER STANDARD 420001 WITH HOT POUR SEAL
 - (EX) TRANSVERSE EXPANSION JOINT PER STANDARD 420001
 - (GR) NO BARS, KEYS LONGITUDINAL CONSTRUCTION JOINT WITH ALL KEYS FACING ONE DIRECTION ALONG INSIDE EDGE OF RAMP PAVEMENT AND SURROUNDING SHOULDER GORE
 - (F) LONGITUDINAL CONSTRUCTION JOINT WITH DRILLED & GROUTED #8 DEFORMED EPOXY COATED TIE BARS, 24" LONG AT 24" C-C
 - (J) LONGITUDINAL SAWED JOINT PER STANDARD 420001.
 - (SL) LONGITUDINAL CONSTRUCTION JOINT PER STANDARD 483001 EXCEPT FOR DRILLED & GROUTED 30" LONG #8 TIE BARS
 - (ST) SAWED TRANSVERSE SHOULDER CONTRACTION JOINT PER STANDARD 483001 (MATCH RAMP PAVEMENT JOINTS IN GORE AREAS)
- LONGITUDINAL CONSTRUCTION JOINT PER STANDARD 420001 EXCEPT FOR DRILLED & GROUTED 24" LONG #8 TIE BARS. SEAL PER ASTM D 3405

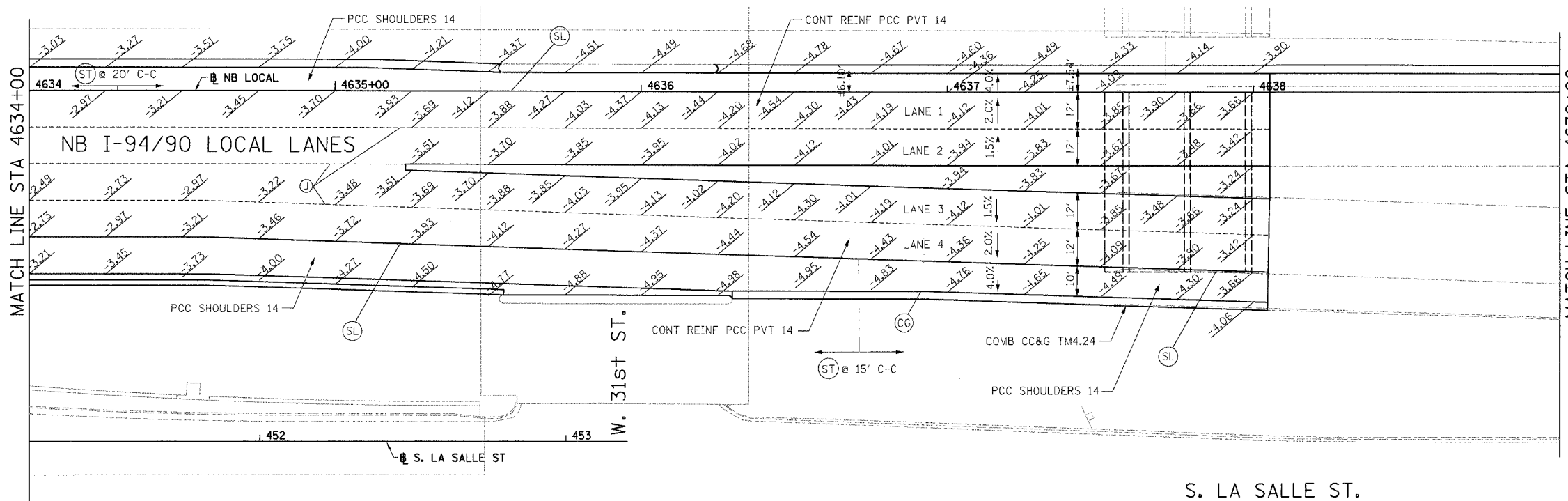

FOR PARTIAL WIDTH FRONTAGE ROAD IMPROVEMENTS, EITHER MATCH TRANSVERSE JOINT SPACING OF EXISTING PAVEMENT WITH NEWLY INSTALLED TRANSVERSE JOINTS OR PLACE NEWLY INSTALLED TRANSVERSE JOINTS AT 15'-0" INTERVALS. PLACE NEWLY INSTALLED TRANSVERSE JOINTS AT THE GREATER OF THESE TWO INTERVALS. SEE DETAIL SHEETS RDT-18A AND RDT-18B FOR PCC BASE COURSE JOINT DETAILS. (INCLUDED IN THE COST OF PORTLAND CEMENT CONCRETE BASE COURSE 9")

NOTES:

1. ELEVATION STATIONED OFF OF NB I-94/90 LOCAL LANES OR S. LA SALLE ST.
2. ELEVATION STATIONED OFF OF RAMP ALIGNMENT
3. SEE ALIGNMENT AND TIES SHEETS FOR CURVE INFORMATION
4. SEE ROADWAY PLAN SHEETS FOR BEGINNING AND END TAPER STATIONS AND TAPER RATES.
5. PAVEMENT ELEVATIONS ALONG EDGE OF PAVEMENTS, EDGE OF SHOULDERS, GORES, RAMPS AND IN AREAS OF SUPERELEVATION TRANSITION ARE PROVIDED AT 25' INTERVALS, FOR ALL ELEVATIONS, REFER TO THE PROFILES AND TYPICAL SECTIONS.
6. SEE ROADWAY DETAIL RDT-8 FOR THE TYING OF THE MEDIAN BARRIER BASE TO THE PCC SHOULDER.

BOWMAN, BARRETT & ASSOCIATES INC.
CONSULTING ENGINEERS
Chicago, Illinois
312.228.0100
www.bbainc.com

REVISIONS	
NAME	DATE

0 20' 40'

JE-17

ILLINOIS DEPARTMENT OF TRANSPORTATION
F.A.I. 94/90 (DAN RYAN EXPRESSWAY)
GARFIELD BLVD TO 31ST STREET (NB LOCAL LANES)
PAVEMENT JOINTING
AND ELEVATION PLANS

SCALE: 1"=20'
DATE: 06/09/06

DRAWN BY: JDC
CHECKED BY: RS

12/4/08 PM 6/7/2006

F.A.I. RTE.	SECTION	COUNTY	TOTAL SHEETS	SHEET NO.
90/94	*	COOK	565	224
STA. 4474+50	TO STA. 4482+00			
FED. ROAD DIST. NO. 1	ILLINOIS	FED. AID PROJECT		
62301	(2021-922 PT2 ETC 2324.6-1P) R-10			

PAV-C-650-CONTR-18 & 19-CONTR-18-pavement marking-010205

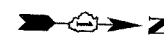
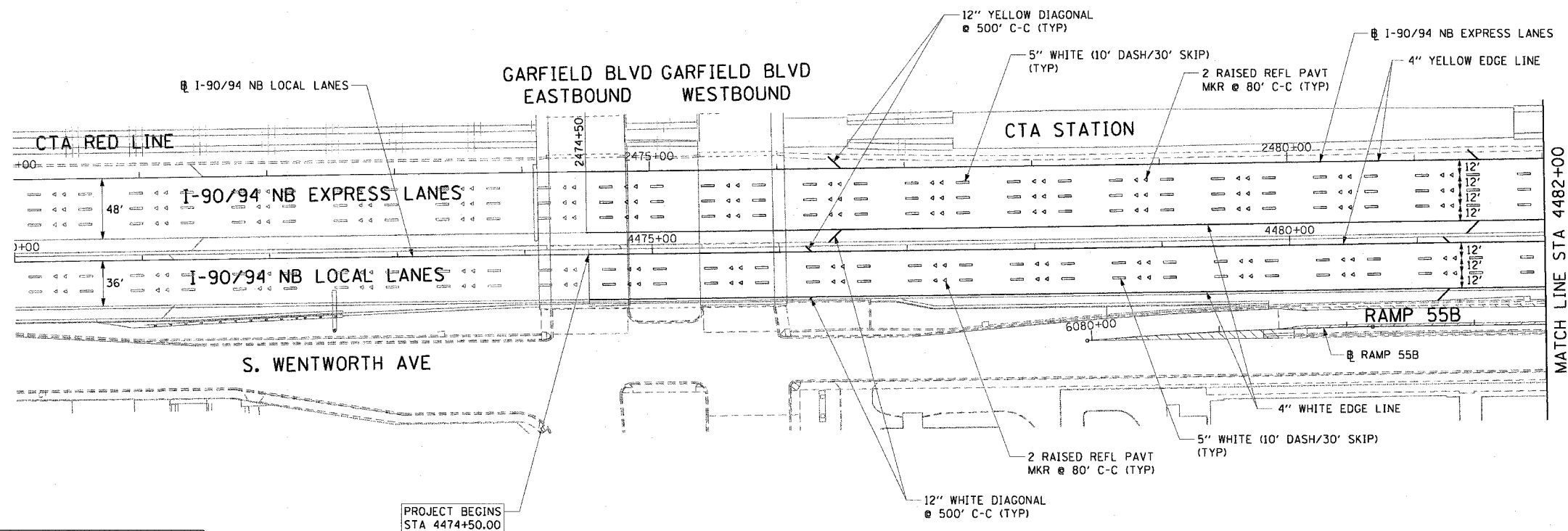

NOTES:

1. ALL PAVEMENT MARKINGS SHALL BE POLYUREA.
2. FOR PAVEMENT MARKING DETAILS, SEE DISTRICT 1 STANDARDS TC-12 AND TC-13.
3. PAVEMENT MARKINGS SHALL MATCH THOSE OF CONTRACT 60A62 AT THE BEGINNING OF THE PROJECT AT STATION 4474+50.
4. SHOULDER DIAGONAL SPACING AND RAISED REFLECTIVE PAVEMENT MARKING SPACING SHALL BE COORDINATED WITH THE SPACING OF CONTRACT 60A62.

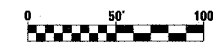

PM-1

REVISIONS	
NAME	DATE

ILLINOIS DEPARTMENT OF TRANSPORTATION
 F.A.I. 90/94 (DAN RYAN EXPRESSWAY)
 GARFIELD BLVD TO 31ST STREET (NB LOCAL LANES)
PROPOSED PAVEMENT MARKING PLANS

SCALE: 1"=50'
 DATE: June 9, 2006

DRAWN BY: PHP
 CHECKED BY: NJH

CTE | AECOM

PROJECT BEGINS
 STA 4474+50.00

6/7/2006 1:47:05 PM

F.A.I. RTE.	SECTION	COUNTY	TOTAL SHEETS	SHEET NO.
90/94	*	COOK	565	226
STA. 4506+00		TO STA. 4529+00		
FED. ROAD DIST. NO. 1 ILLINOIS FED. AID PROJECT				
62301 • (2021-922 PT2 ETC 2324.6-1P) R-10				

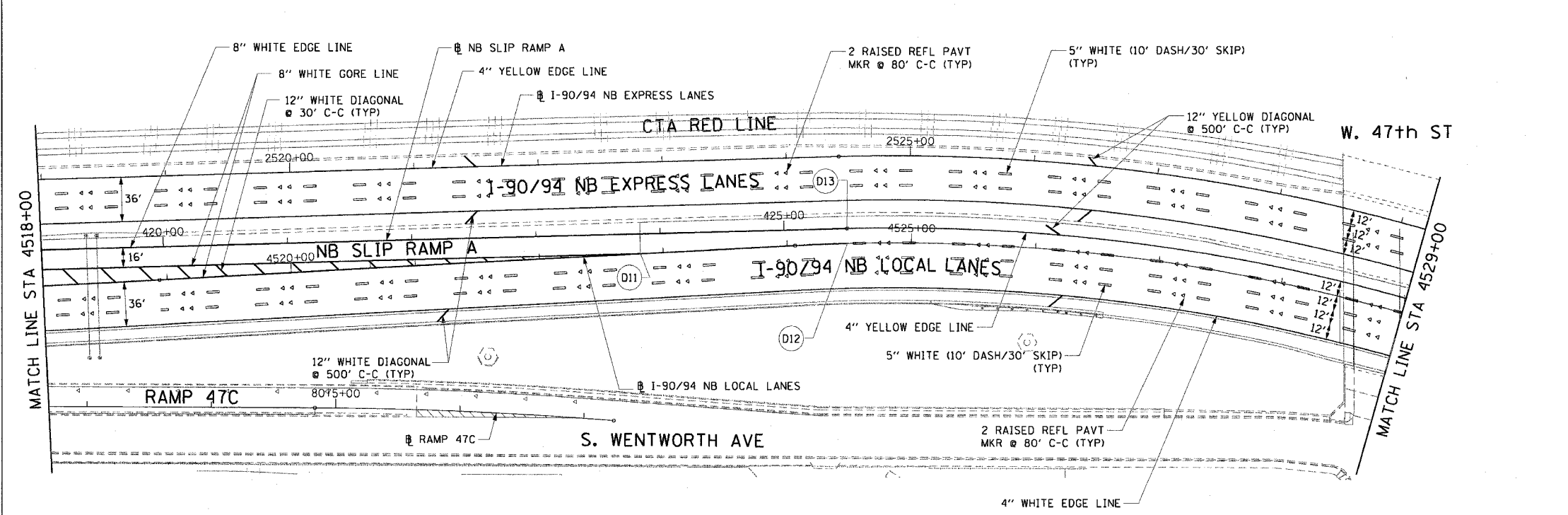
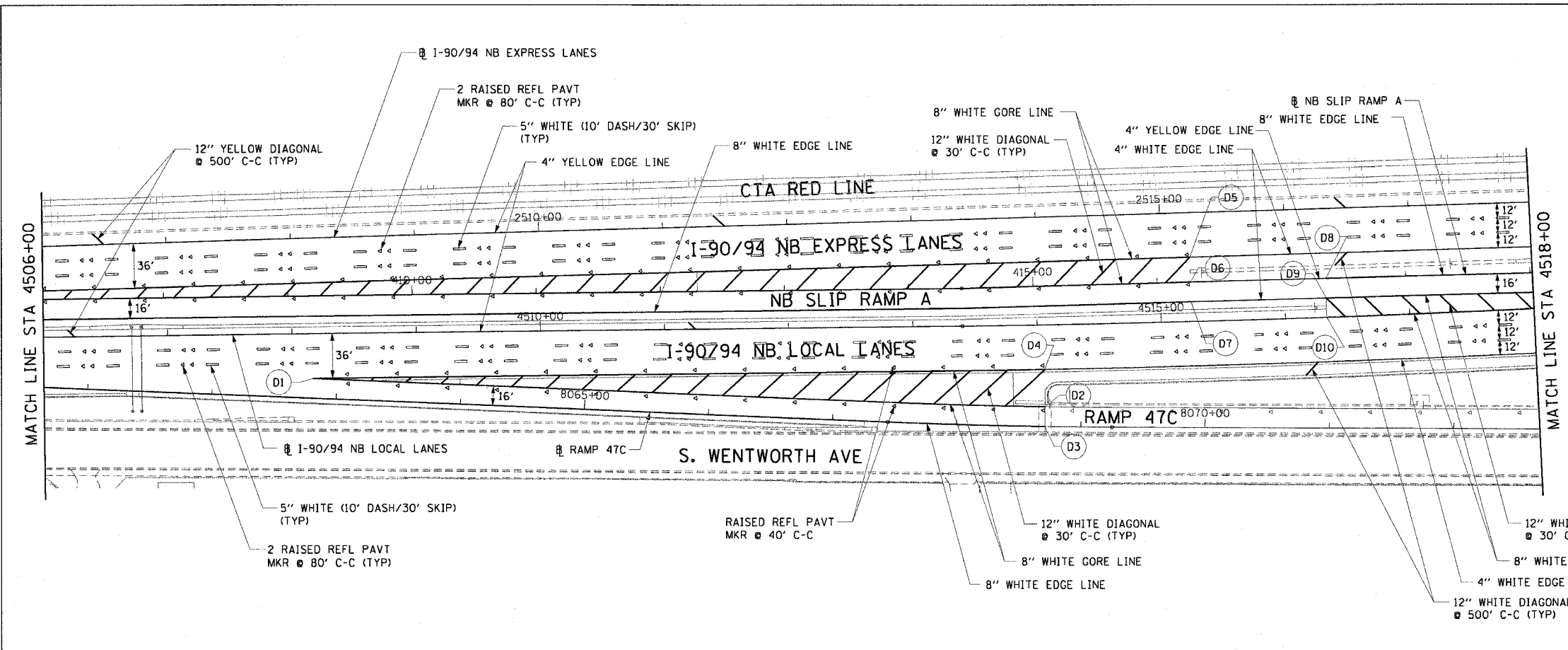

- NOTES:
1. ALL PAVEMENT MARKINGS SHALL BE POLYUREA.
 2. FOR PAVEMENT MARKING DETAILS, SEE DISTRICT 1 STANDARDS TC-12 AND TC-13.
 3. THE PAVEMENT MARKINGS SHALL MATCH THOSE OF CONTRACT 62799 AT RAMP 47C.

PT.	STATION	OFFSET
D1	4508+16.41	36.00' RT
D2	8068+71.06	16.00' LT
D3	8068+71.06	0.00'
D4	4514+05.49	36.00' RT
D5	2515+23.46	36.00' RT
D6	416+26.88	0.00'
D7	416+26.88	16.00' RT
D8	417+35.69	0.00'
D9	417+35.69	16.00' RT
D10	4516+33.21	0.00'
D11	4522+81.63	0.00'
D12	4524+48.42	0.00'
D13	4524+48.42	12.00' LT

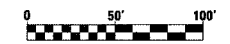

REVISIONS	
NAME	DATE

ILLINOIS DEPARTMENT OF TRANSPORTATION
 F.A.I. 90/94 (DAN RYAN EXPRESSWAY)
 GARFIELD BLVD TO 31ST STREET (NB LOCAL LANES)
 PROPOSED PAVEMENT MARKING PLANS

SCALE: 1"=50'
 DATE: June 9, 2006

DRAWN BY: PHP
 CHECKED BY: NJH

CTE | AECOM

P:\V\40468\civil\NB-cvtr 13 & 19\slp\entr 18 pavement marking\m800322c.dwg 6/7/2006 1:47:08 PM

F.A.I.	SECTION	COUNTY	TOTAL SHEETS	SHEET NO.
94/90		COOK	565	227
STA.	TO STA.			
FED. ROAD DIST. NO.	ILLINOIS	FED. AID PROJECT		
62301	*(2021-922 PT2 ETC 2324.6-1P) R-10			

PI	STATION	OFFSET
E1	4532+70.61	00.00' RT
E2	4535+70.61	00.00' RT
E3	4538+49.44	36.00' RT
E4	6064+73.20	16.00' LT

- NOTES:
1. ALL PAVEMENT MARKINGS MUST BE POLYUREA
 2. FOR PAVEMENT MARKING DETAILS, SEE DISTRICT 1 STANDARDS TC-12 AND TC-13.

PI	STATION	OFFSET
E5	4542+13.87	36.00' RT
E6	2543+37.04	36.00' RT
E7	817+38.29	16.00' LT
E8	816+59.86	16.00' LT
E9	816+59.86	00.00' RT
E10	4542+61.71	00.00' RT
E11	4545+98.99	36.00' RT
E12	4548+91.39	36.00' RT
E13	8054+27.30	16.00' LT

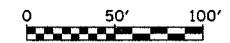

REVISIONS	
NAME	DATE

ILLINOIS DEPARTMENT OF TRANSPORTATION
 F.A.I. 94/90 (DAN RYAN EXPRESSWAY)
 GARFIELD BLVD TO 31ST STREET (NB LOCAL LANES)
 PROPOSED PAVEMENT MARKING PLANS

SCALE: 1"=50'
 DATE: 06/09/06

DRAWN BY: RA
 CHECKED BY: RS

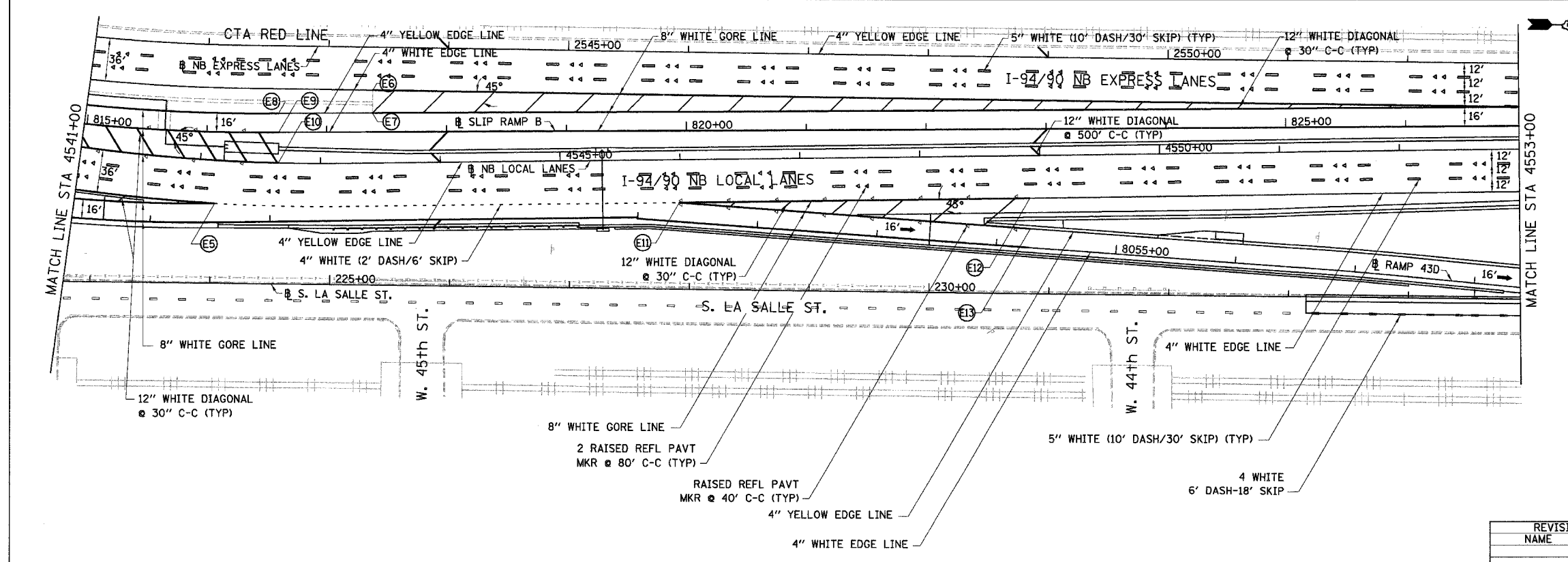
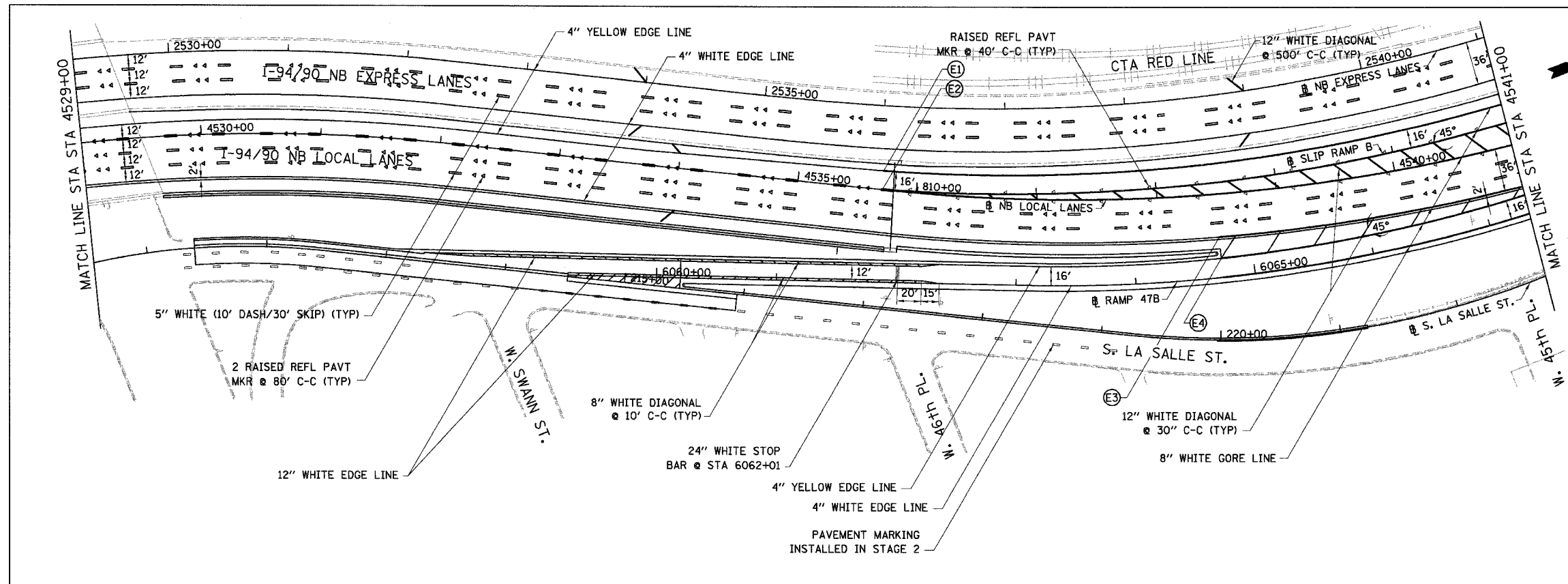

BOWMAN, BARRETT & ASSOCIATES INC.
 CONSULTING ENGINEERS
 Chicago, Illinois
 312.228.0100
 www.bbainc.com

6/7/2006
 16:20 PM
 I:\650\cadd\94\90\9490\9490.dwg

F.A.I.	SECTION	COUNTY	TOTAL SHEETS	SHEET NO.
94/90		COOK	565	228
STA.	TO STA.			
FED. ROAD DIST. NO. ILLINOIS FED. AID PROJECT				
62301 *I201-922 PT2 ETC 2324.6-1P) R-10				

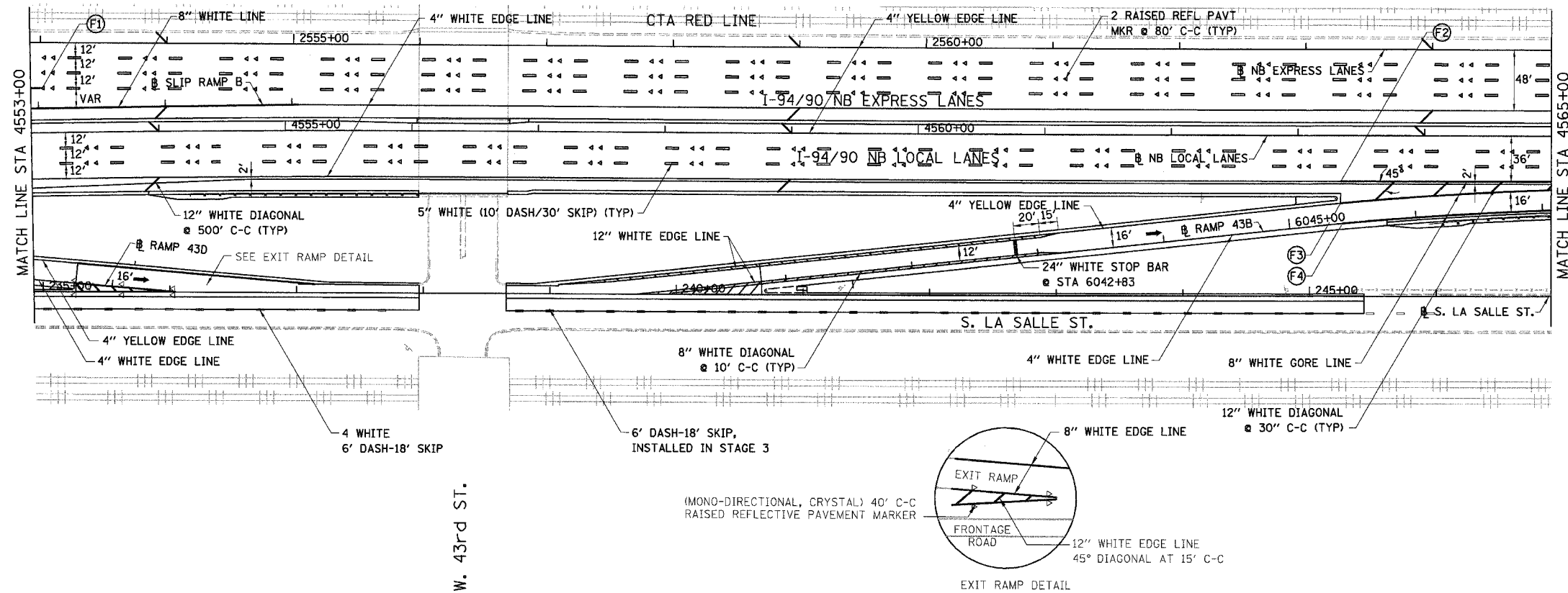

PI	STATION	OFFSET
F1	2553+01.64	36.00' RT
F2	4563+33.87	36.00' RT
F3	6045+41.66	16.00' LT
F4	6045+41.66	00.00' RT

(MONO-DIRECTIONAL, CRYSTAL) 40' C-C RAISED REFLECTIVE PAVEMENT MARKER

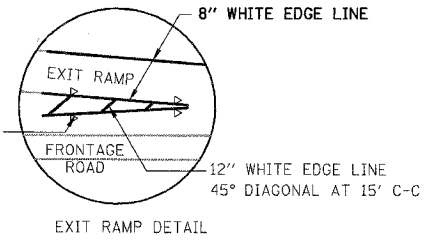

- NOTES:
1. ALL PAVEMENT MARKINGS MUST BE POLYUREA
 2. FOR PAVEMENT MARKING DETAILS, SEE DISTRICT 1 STANDARDS TC-12 AND TC-13.

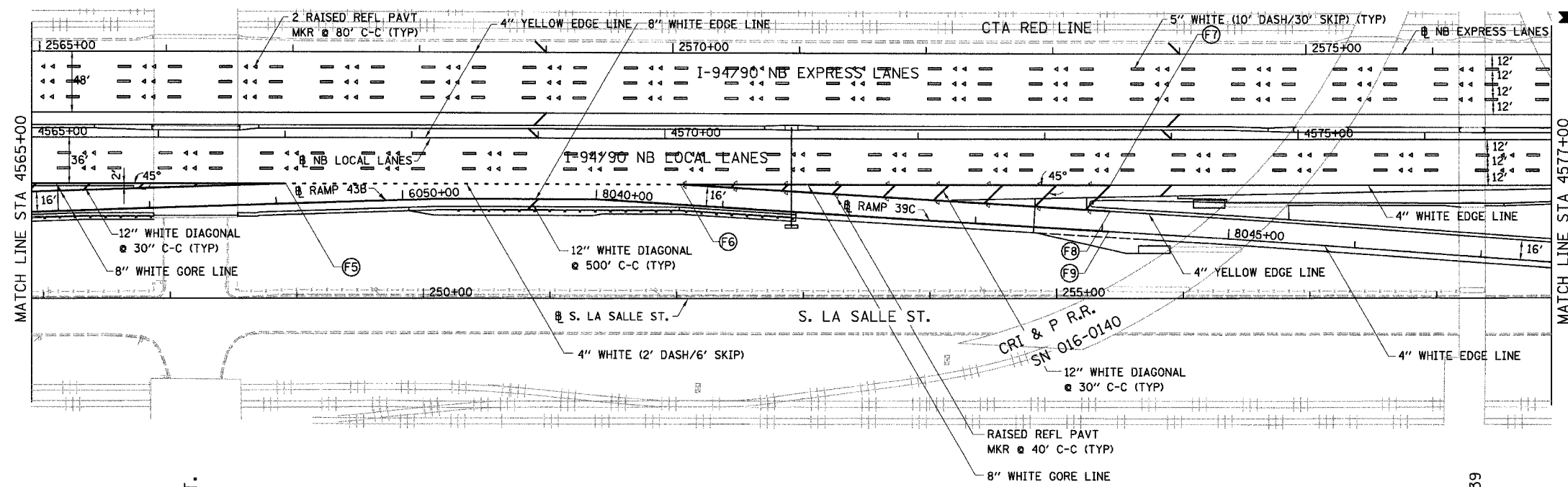

PI	STATION	OFFSET
F5	4567+00.53	36.00' RT
F6	4570+12.17	36.00' RT
F7	4573+51.61	36.00' RT
F8	8044+05.38	16.00' LT
F9	8044+05.38	00.00' RT

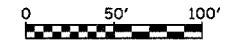

REVISIONS	
NAME	DATE

ILLINOIS DEPARTMENT OF TRANSPORTATION
 F.A.I. 94/90 (DAN RYAN EXPRESSWAY)
 GARFIELD BLVD TO 31ST STREET (NB LOCAL LANES)
 PROPOSED PAVEMENT MARKING PLANS

SCALE: 1"=50'
 DATE: 06/09/06

DRAWN BY: RA
 CHECKED BY: RS

BOWMAN, BARRETT & ASSOCIATES INC.
 CONSULTING ENGINEERS
 Chicago, Illinois
 312.228.0100
 www.bbandainc.com

W. ROOT ST.

CJ R.R.
 SN 016-0139

PM-05

6/7/2006

F.A.I.	SECTION	COUNTY	TOTAL SHEETS	SHEET NO.
94/90	*	COOK	565	229
STA.		TO STA.		
FED. ROAD DIST. NO.		ILLINOIS	FED. AID PROJECT	
62301		*(2021-922 PT2 ETC 2324.6-1P) R-10		

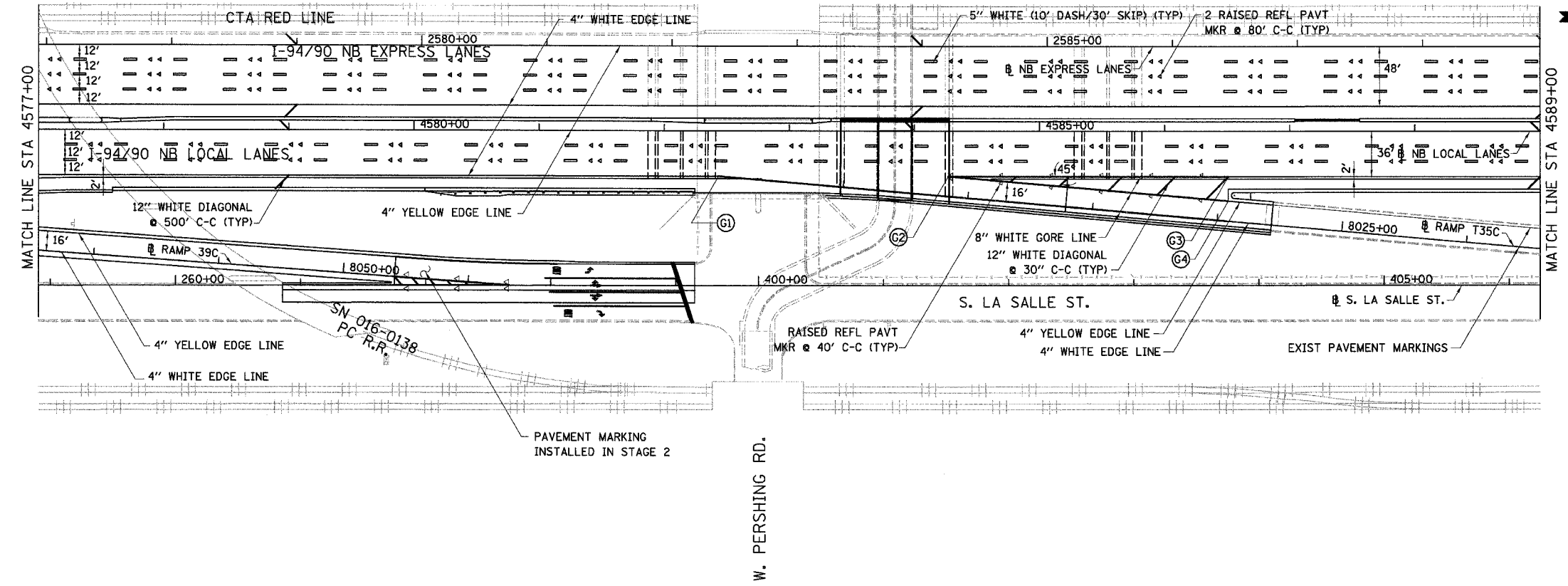

PI	STATION	OFFSET
G1	4582+43.53	36.00' RT
G2	4584+27.11	36.00' RT
G3	4586+50.88	36.00' RT
G4	8024+07.50	16.00' LT

- NOTES:
1. ALL PAVEMENT MARKINGS MUST BE POLYUREA
 2. FOR PAVEMENT MARKING DETAILS, SEE DISTRICT 1 STANDARDS TC-12 AND TC-13.
 3. PAVEMENT MARKINGS MUST MATCH THOSE OF CONTRACT 62584 AT RAMPS T35C AND T39B.

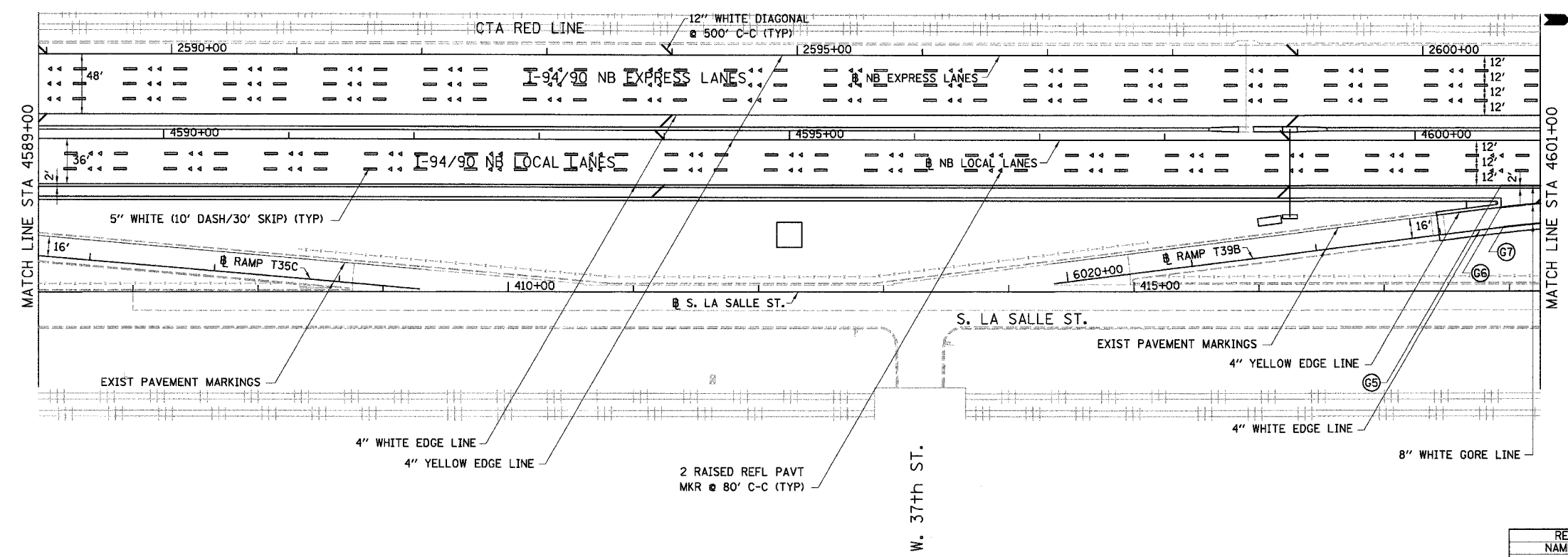

PI	STATION	OFFSET
G5	4600+68.52	36.00' RT
G6	6023+50.25	16.00' LT
G7	6023+50.34	00.00' RT

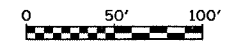

REVISIONS	
NAME	DATE

PM-06
 ILLINOIS DEPARTMENT OF TRANSPORTATION
 F.A.I. 94/90 (DAN RYAN EXPRESSWAY)
 GARFIELD BLVD TO 31ST STREET (NB LOCAL LANES)
 PROPOSED PAVEMENT MARKING PLANS
 SCALE: 1"=50'
 DATE: 06/09/06
 DRAWN BY: RA
 CHECKED BY: RS

BOWMAN, BARRETT & ASSOCIATES INC
 CONSULTING ENGINEERS
 Chicago, Illinois
 312.228.0100
 www.bbainc.com

F.A.I.	SECTION	COUNTY	TOTAL SHEETS	SHEET NO.
94/90	*	COOK	565	230
STA.	TO STA.			
FED. ROAD DIST. NO.	ILLINOIS	FED. AID PROJECT		
62301	*(2021-922 PT2 ETC 2324.6-1P) R-10			

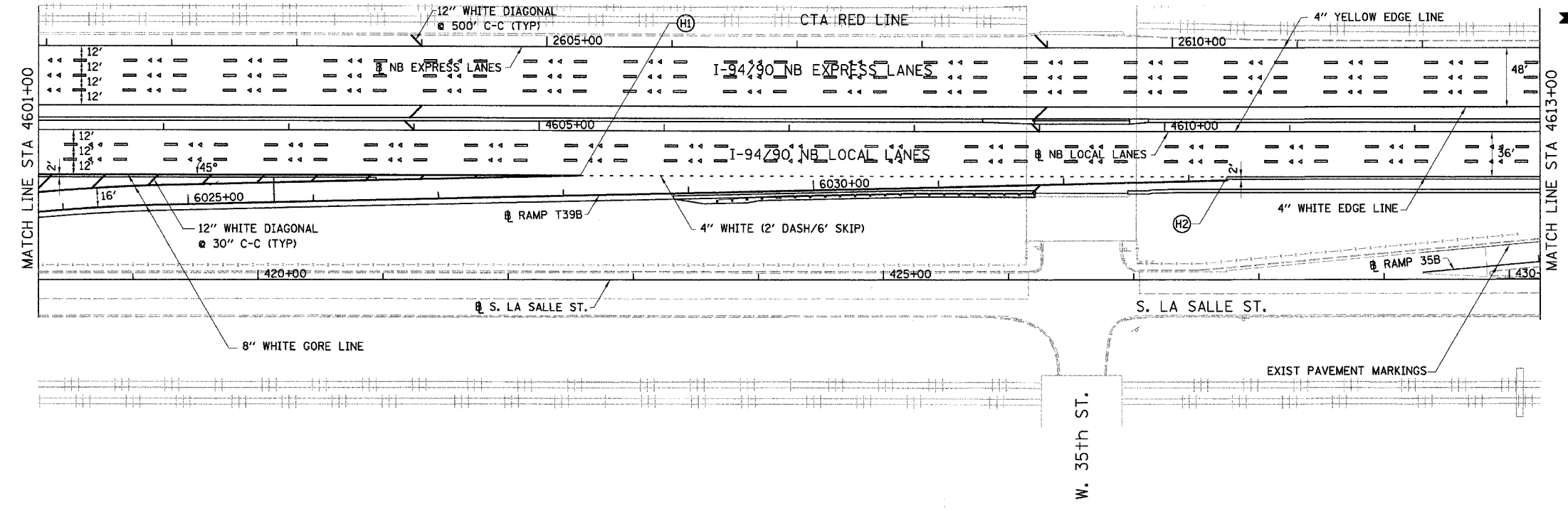

PI	STATION	OFFSET
H1	4505+33.05	36.00' RT
H2	4610+50.00	36.00' RT

- NOTES:
1. ALL PAVEMENT MARKINGS MUST BE POLYUREA
 2. FOR PAVEMENT MARKING DETAILS, SEE DISTRICT 1 STANDARDS TC-12 AND TC-13.
 3. PAVEMENT MARKINGS MUST MATCH THOSE OF CONTRACT 62584 AT RAMP 35B.

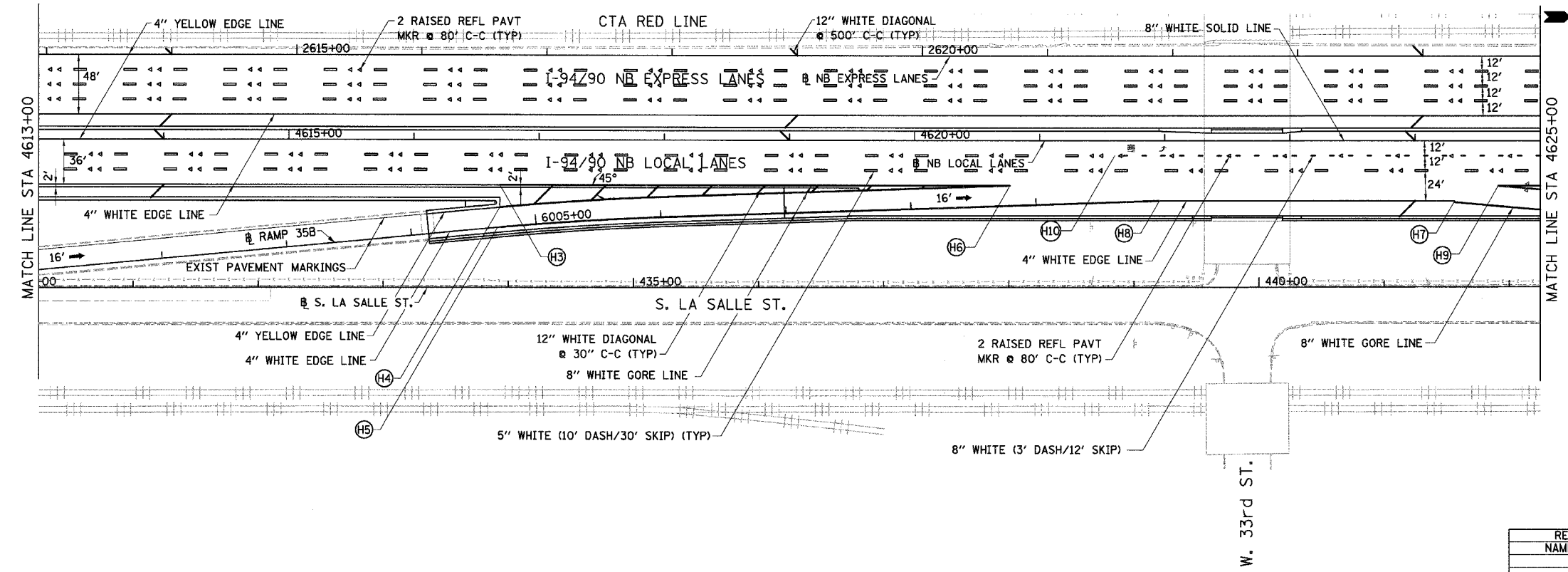

PI	STATION	OFFSET
H3	4616+68.65	36.00' RT
H4	6004+72.35	16.00' LT
H5	6004+69.11	00.00' RT
H6	4620+76.28	36.00' RT
H7	4624+31.71	48.00' RT
H8	4621+95.70	48.00' RT
H9	4624+66.44	36.00' RT
H10	4621+60.00	12.00' RT

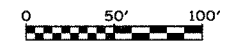

PM-07

REVISIONS	
NAME	DATE

ILLINOIS DEPARTMENT OF TRANSPORTATION
 F.A.I. 94/90 (DAN RYAN EXPRESSWAY)
 GARFIELD BLVD TO 31ST STREET (NB LOCAL LANES)
 PROPOSED PAVEMENT MARKING PLANS

SCALE: 1"=50'
 DATE: 06/09/06

DRAWN BY: RA
 CHECKED BY: RS

BOWMAN, BARRETT & ASSOCIATES INC.
 CONSULTING ENGINEERS
 Chicago, Illinois
 312.228.0100
 www.bbdatinc.com

6/7/2006 10:58:17 AM
 n:\620\contract\94\90\ch06\620\62010.dwg

PROPOSED SIGNING SCHEDULE

SHEET NUMBER	STRUCTURE NUMBER	STATION	SIGN CALLOUT	SIGN PANEL - TYPE 1	SIGN PANEL - TYPE 2	SIGN PANEL - TYPE 3	REMOVE SIGN PANEL ASSEMBLY - TYPE B	REMOVE SIGN PANEL - TYPE 3	STRUCTURAL STEEL SIGN SUPPORT - BREAKAWAY	TELESCOPING STEEL SIGN SUPPORT	METAL POST - TYPE B	WOOD SIGN SUPPORT	BASE FOR TELESCOPING STEEL SIGN SUPPORT	OVERHEAD SIGN STRUCTURE - SPAN, TYPE I-A (4'-0" X 4'-6")	OVERHEAD SIGN STRUCTURE - SPAN, TYPE II-A (4'-6" X 5'-3")	OVERHEAD SIGN STRUCTURE - SPAN, TYPE III-A (5'-0" X 7'-0")	OVERHEAD SIGN STRUCTURE - BRIDGE MOUNTED	OVERHEAD SIGN STRUCTURE WALKWAY	CONCRETE FOUNDATIONS	DRILLED SHAFT CONCRETE FOUNDATIONS	REMOVE OVERHEAD SIGN STRUCTURE - SPAN	REMOVE OVERHEAD SIGN STRUCTURE - BRIDGE MOUNTED	REMOVE GROUND-MOUNTED SIGN SUPPORT	REMOVE CONCRETE FOUNDATION - GROUND MOUNT	REMOVE CONCRETE FOUNDATION - OVERHEAD	REMOVE AND RE-ERECT EXISTING SIGN
				SQ FT	SQ FT	SQ FT	EACH	SQ FT	POUND	FOOT	FOOT	FOOT	EACH	FOOT	FOOT	FOOT	FOOT	FOOT	FOOT	CU YD	CU YD	EACH	EACH	EACH	EACH	EACH
SG-02	-	4490+18	ES02-01																			1				2
SG-02	-	4486+25	GS02-01				1																			
SG-02	-	4505+11	GS02-02					85															2		2	
SG-02	-	4485+50	PS02-01		16																					
SG-02	-	4488+00	PS02-02	4						12				1												
SG-02	-	4496+50	PS02-03	20						8				1												
SG-02	-	4497+00	PS02-04		12					10.5				1												
SG-02	ISO161094L057.3	4498+00	PS02-05			168																				
SG-03	-	47TH ST.	ES03-01					91.25																		
SG-03	-	4517+07	GS03-01				1																			
SG-03	-	4515+00	GS03-02					70																2		2
SG-03	-	4518+01	GS03-04				1																			
SG-03	-	4519+00	GS03-05					70																2		2
SG-03	-	4528+00	GS03-06					51															2		2	
SG-03	ISO161094L057.1	4506+75	PS03-01			310																				
SG-03	-	4514+10	PS03-02		16.3					15.25				1												
SG-03	-	4516+25	PS03-03		16					12				1												
SG-03	-	4517+35	PS03-04	4						8				1												
SG-03	ISO161094L056.9	4518+40	PS03-05			296										98										
SG-04	-	4534+65	PS04-01		12							19														
SG-04	ISO161094L056.60	4535+80	PS04-02			606.25										74										
SG-04	-	4538+50	W4-3		16							32														
SG-04	-	4540+00	ES04-01					120																2		2
SG-04	-	4542+67	W12-1		16																					
SG-04	-	4543+75	PS04-03	4						12				1												
SG-04	-	4544+90	ES04-03							8				1												
SG-04	ISO161094L056.43	4545+35	PS04-04			323						42														1
SG-04	-	4545+50	ES04-02					88																		
SG-04	-	4548+40	W13-3		12																			2		2
SG-04	-	4549+50	PS04-05			45																				
SG-04	-	4550+30	R5-1a	12																						
SG-04	-	4540+17	ES04-04																							1
SG-04	-	4545+35	ES04-05																							1
SG-05	-	4553+50	R5-1	18																						
SG-05	-	4555+00	ES05-01					80																2		2
SG-05	-	4559+40	PS05-01		12																					
SG-05	-	4560+10	ES05-04																							
SG-05	-	4561+09	ES05-05																							1
SG-05	-	4562+35	ES05-06																							1
SG-05	-	4563+35	W4-3		16							32														
SG-05	-	4569+50	ES05-02					80																2		2
SG-05	-	4568+20	PS05-02	4						8				1												
SG-05	-	4571+00	ES05-03					120																		
SG-05	ISO161094L055.94	4571+00	PS05-03			385																				
SG-05	-	4573+68	W13-3		12																					
SG-05	-	4574+40	PS05-04			45																				
SG-05	-	4575+38	ES05-07																							
SG-05	-	4576+00	ES05-08																							
SG-05	-	4576+60	R5-1a	12																						
SG-05	-	4571+00	ES05-09																							
SG-06	-	4577+16	ES06-05																							1
SG-06	-	4579+75	R5-1	18																						1
SG-06	-	4581+87	ES06-03					73.5																		
SG-06	IB0161094L055.73	4582+26	PS06-01			640.5																		2		2
SG-06	-	4582+26	ES06-02																							
SG-06	-	4586+70	W13-3		12																					
SG-06	-	4587+22	PS06-02			45																				
SG-06	-	4591+05	GM06-01			180																				
SG-06	-	4594+60	PS06-05	4																						
SG-06	-	4597+80	PS06-03		12																					



REVISIONS	
NAME	DATE

ILLINOIS DEPARTMENT OF TRANSPORTATION
 F.A.I. 90/94 (DAN RYAN EXPRESSWAY)
 GARFIELD BLVD TO 31ST STREET (NB LOCAL LANES)

SCHEDULE OF QUANTITIES
 FOR PROPOSED SIGNING

SCALE: NONE
 DATE: June 9, 2006

DRAWN BY: NJH
 CHECKED BY: RMG

P:\94068\CH\1116\CH\1116-18 & 19\Signing Plans\SSIB002A.DWG 10/17/05 AM 6/8/2006

PROPOSED SIGNING SCHEDULE

SHEET NUMBER	STRUCTURE NUMBER	STATION	SIGN CALLOUT	SIGN PANEL-TYPE 1	SIGN PANEL-TYPE 2	SIGN PANEL-TYPE 3	REMOVE SIGN PANEL ASSEMBLY-TYPE B	REMOVE SIGN PANEL-TYPE 3	STRUCTURAL STEEL SIGN SUPPORT - BREAKAWAY	TELESCOPING STEEL SIGN SUPPORT	METAL POST - TYPE B	WOOD SIGN SUPPORT	BASE FOR TELESCOPING STEEL SIGN SUPPORT	OVERHEAD SIGN STRUCTURE - SPAN, TYPE I-A (4'-0" X 4'-6")	OVERHEAD SIGN STRUCTURE - SPAN, TYPE II-A (4'-6" X 5'-3")	OVERHEAD SIGN STRUCTURE - SPAN, TYPE III-A (5'-0" X 7'-0")	OVERHEAD SIGN STRUCTURE - BRIDGE MOUNTED	OVERHEAD SIGN STRUCTURE WALKWAY	CONCRETE FOUNDATIONS	DRILLED SHAFT CONCRETE FOUNDATIONS	REMOVE OVERHEAD SIGN STRUCTURE - SPAN	REMOVE OVERHEAD SIGN STRUCTURE - BRIDGE MOUNTED	REMOVE GROUND-MOUNTED SIGN SUPPORT	REMOVE CONCRETE FOUNDATION - GROUND MOUNT	REMOVE CONCRETE FOUNDATION - OVERHEAD	REMOVE AND RE-ERECT EXISTING SIGN	
				SO FT	SO FT	SO FT	EACH	SO FT	POUND	FOOT	FOOT	FOOT	EACH	FOOT	FOOT	FOOT	FOOT	FOOT	FOOT	FOOT	CU YD	CU YD	EACH	EACH	EACH	EACH	EACH
SG-06		4599+00	ES06-04									15															1
SG-06	1S016I094L055.41	4599+00	PS06-04			85										70		50		10.7							
SG-06		4600+00	W4-1		16							32															
SG-07		4604+88	ES07-03									18															1
SG-07		4607+95	ES07-07																								1
SG-07		4608+16	ES07-04									17															1
SG-07		4611+00	ES07-05									15															1
SG-07		4615+80	ES07-06									15															1
SG-07		4616+00	W4-3		16							32															
SG-07		4621+00	PS07-01	4																							
SG-07	1B016I094L054.97	4622+31	PS07-02			639				8			1				54.5										
SG-07		4622+31	ES07-02																			1					
SG-08		4627+50	W13-3		12							15															
SG-08		4629+38	PS08-01			37.5						36															
SG-08		4630+00	R5-1a	12								26															
SG-08		4630+38	ES08-03									22															1
SG-08		4631+25	R5-1	18								28															
SG-08		4635+47	ES08-02																			1					
SG-08	1B016I094L054.72	4635+47	PS08-02			567											55										
			TOTALS	134	224.3	4,372.25	3	928.75	922	109.75	128	730	11	352	98	70	161.5	367.8	2.1	95.1	1	3	20	20	6	13	



REVISIONS	
NAME	DATE

ILLINOIS DEPARTMENT OF TRANSPORTATION
F.A.I. 90/94 (DAN RYAN EXPRESSWAY)
GARFIELD BLVD TO 31ST STREET (NB LOCAL LANES)

SCHEDULE OF QUANTITIES
FOR PROPOSED SIGNING

SCALE: NONE
DATE: June 9, 2006

DRAWN BY: NJH
CHECKED BY: RMG

P:\P468\Civil\8-Chrs 18 & 19\Signing Plans\SS60022A.SW 10/21/2006 5:18:20 AM

F.A.I. RTE.	SECTION	COUNTY	TOTAL SHEETS	SHEET NO.
90/94	*	COOK	565	234
STA. 4474+50	TO STA. 4482+00			
FED. ROAD DIST. NO. 1 ILLINOIS		FED. AID PROJECT		
62301		* (2021-922 PT2 ETC 2324.6-1P) R-10		

F:\P\4468\0\1\18-Cats 18 & 19\SW-Cat 18\Signing Plans\18002AS.H

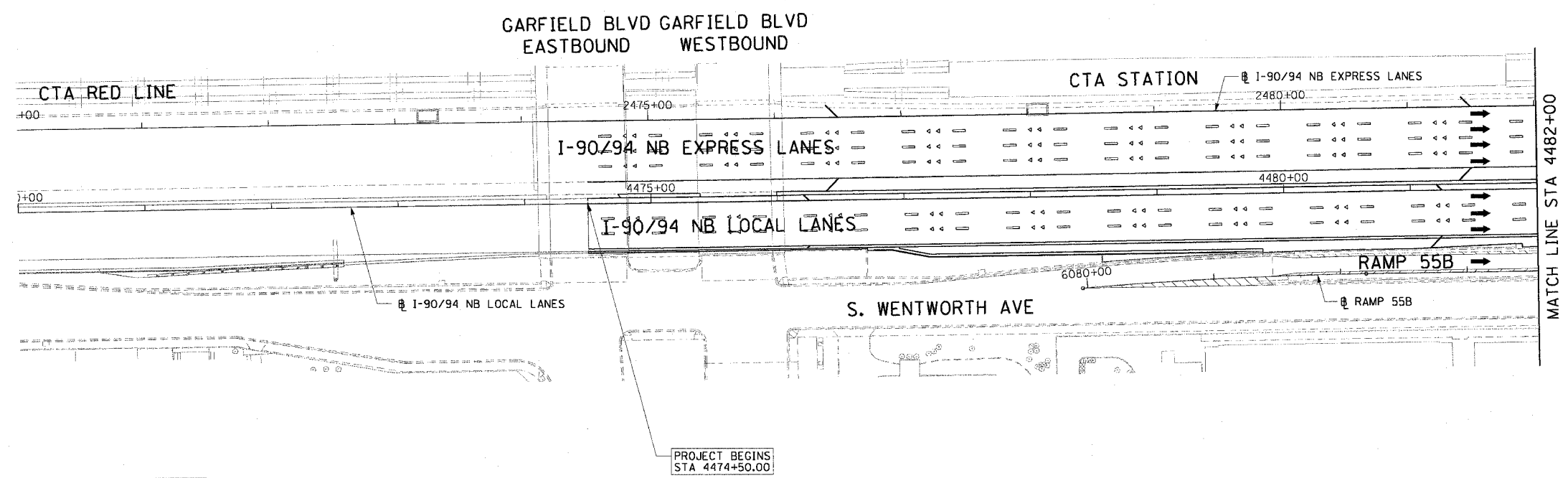

CTE | AECOM

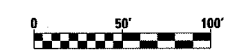

SG-01

REVISIONS	
NAME	DATE

ILLINOIS DEPARTMENT OF TRANSPORTATION
F.A.I. 90/94 (DAN RYAN EXPRESSWAY)
GARFIELD BLVD TO 31ST STREET (NB LOCAL LANES)

PROPOSED SIGNING PLANS

SCALE: 1"=50'
DATE: June 9, 2006

DRAWN BY: PHP
CHECKED BY: RMG

6/7/2006 4:22:11 PM

F.A.I. RTE.	SECTION	COUNTY	TOTAL SHEETS	SHEET NO.
90/94		COOK	565	235
STA. 4482+00		TO STA. 4506+00		
FED. ROAD DIST. NO. 1 ILLINOIS FED. AID PROJECT				
62301 • (2021-922 PT2 ETC 2324.6-1P) R-10				

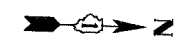
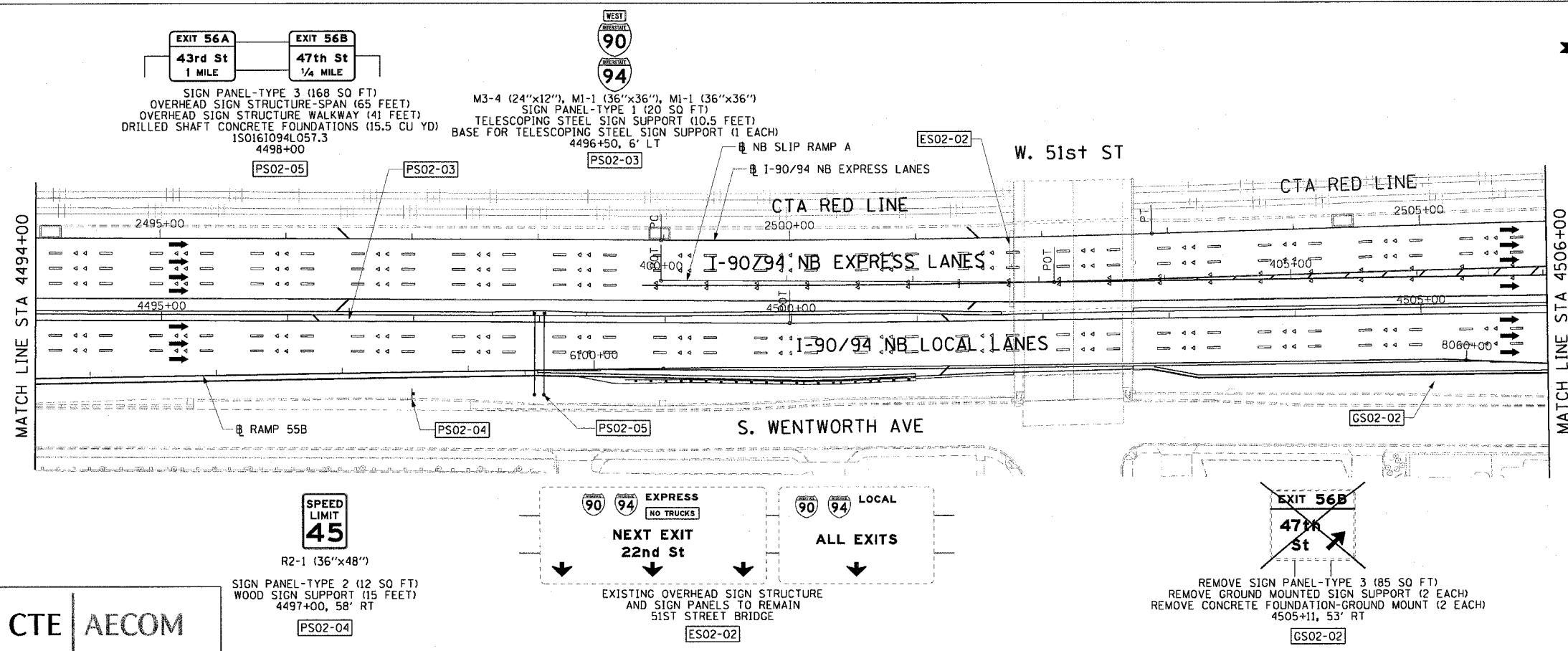
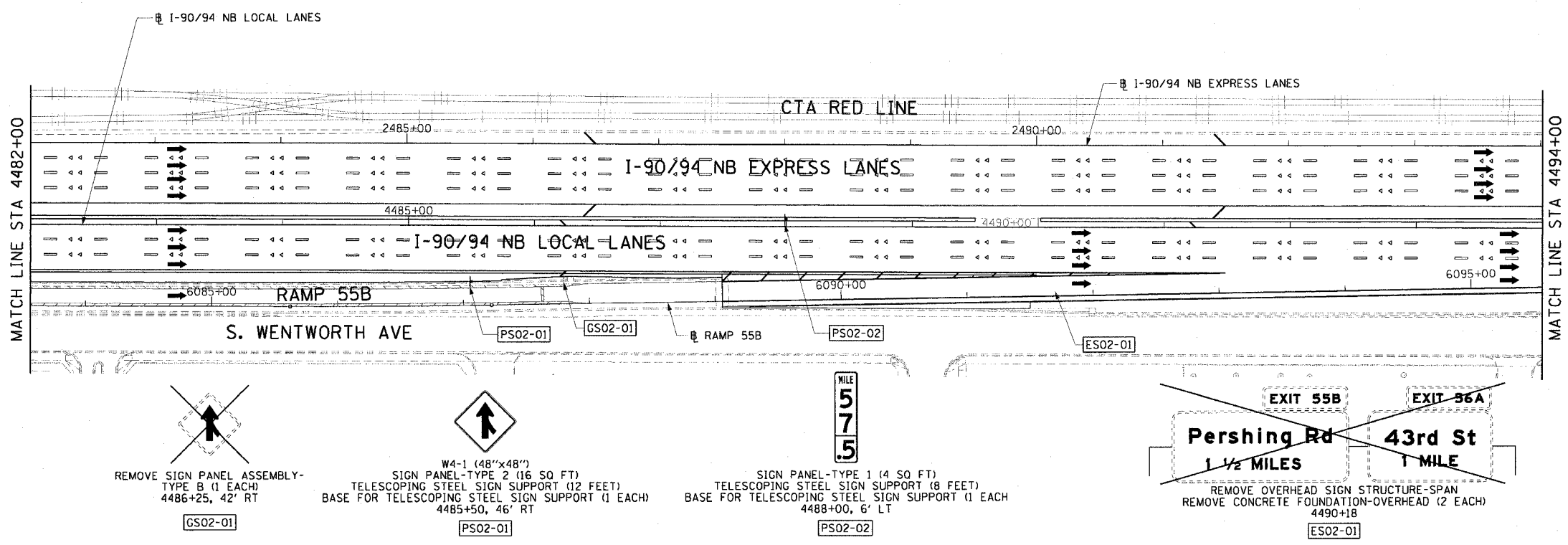
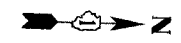

LEGEND:

- [ESXX-XX] EXISTING OVERHEAD OR CANTILEVER SIGNS
- [GSXX-XX] EXISTING POST MOUNTED SIGNS
- [PSXX-XX] PROPOSED SIGNS

NOTES:

1. FOR SIGN PANEL AND TRUSS DETAILS SEE OVERHEAD SIGN STRUCTURE DETAIL SHEETS.
2. FOR GROUND AND BARRIER WALL MOUNTED SIGNS SEE THE PROPOSED SIGN PANEL DETAIL SHEETS
3. SEE ROADWAY DETAILS FOR MOUNTING OF PROPOSED SIGN PS02-01.

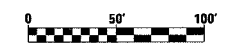

REVISIONS	
NAME	DATE

SG-02
ILLINOIS DEPARTMENT OF TRANSPORTATION
F.A.I. 90/94 (DAN RYAN EXPRESSWAY)
GARFIELD BLVD TO 31ST STREET (NB LOCAL LANES)
PROPOSED SIGNING PLANS
SCALE: 1"=50'
DATE: June 9, 2006
DRAWN BY: PHP
CHECKED BY: RMG

CTE | AECOM

F:\P\40465\CH\NB-Cnrs 18 & 19\SIGNING Plans\180222A-SHT 6/7/2006 4:22:37 PM

F.A.I. RTE.	SECTION	COUNTY	TOTAL SHEETS	SHEET NO.
90/94		COOK	565	236
STA. 4506+00	TO STA. 4529+00			
FED. ROAD DIST. NO. 1 ILLINOIS		FED. AID PROJECT		
62301		(2021-922 PT2 ETC 2324.6-1P) R-10		

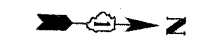

MILE 570

SIGN PANEL-TYPE 1 (4 SQ FT)
TELESCOPING STEEL SIGN SUPPORT (8 FEET)
BASE FOR TELESCOPING STEEL SIGN SUPPORT (1 EACH)
4517+35, 39' LT

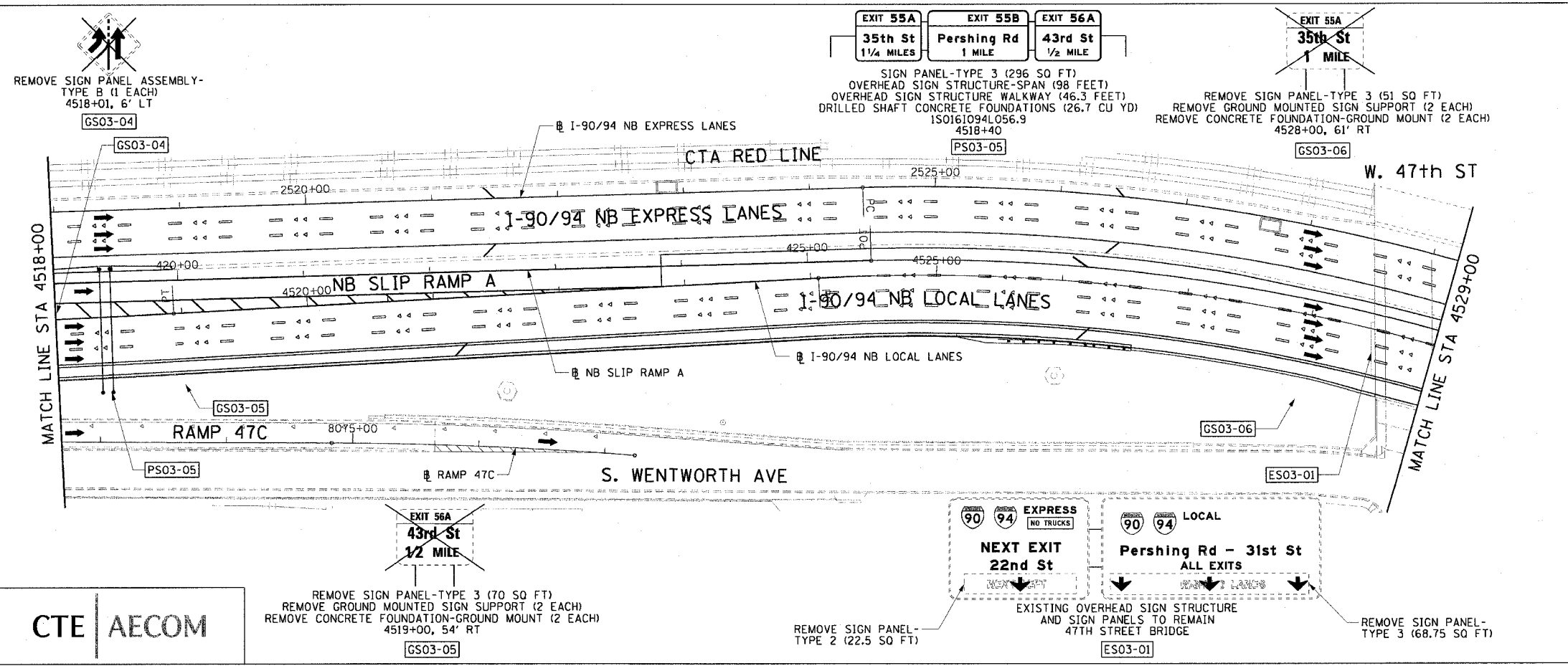
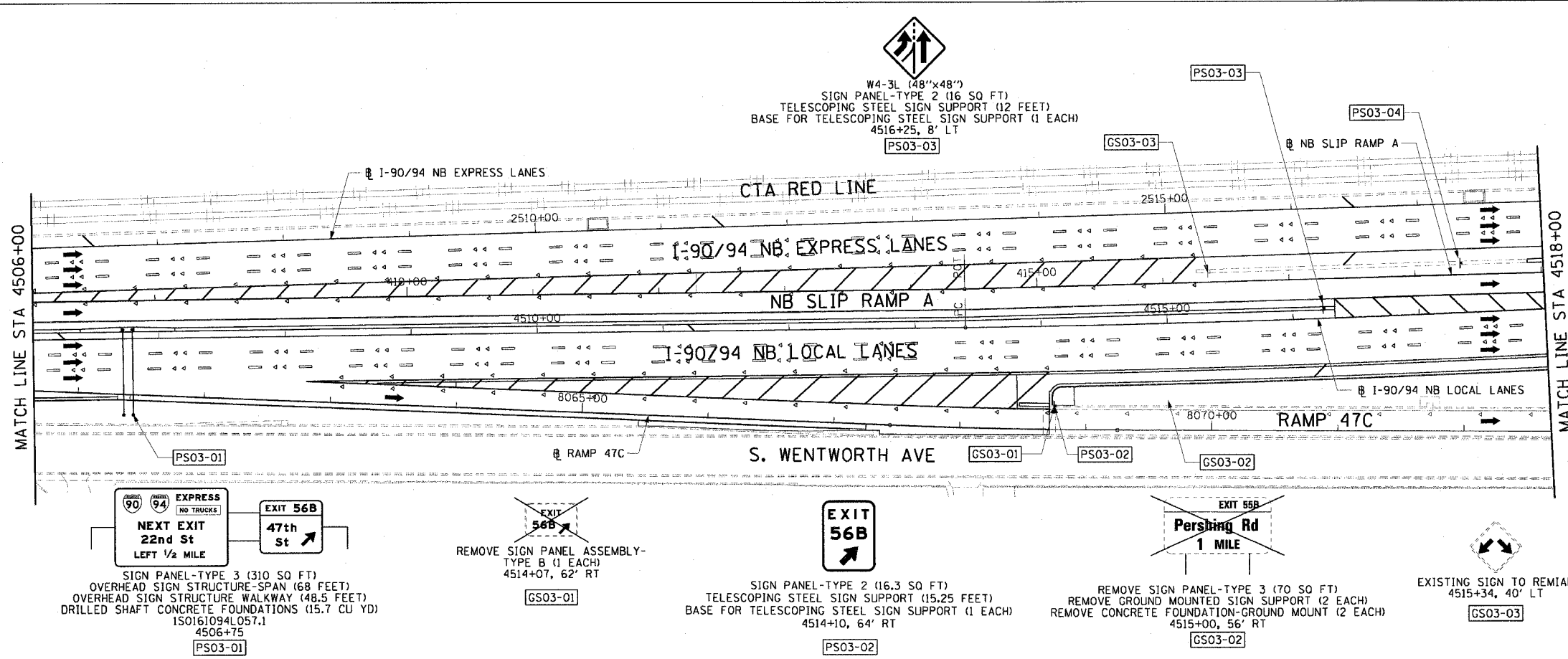

- LEGEND:
- ESXX-XX EXISTING OVERHEAD OR CANTILEVER SIGNS
 - GSXX-XX EXISTING POST MOUNTED SIGNS
 - PSXX-XX PROPOSED SIGNS
- NOTES:
1. FOR SIGN PANEL AND TRUSS DETAILS SEE OVERHEAD SIGN STRUCTURE DETAIL SHEETS.
 2. FOR GROUND AND BARRIER WALL MOUNTED SIGNS SEE THE PROPOSED SIGN PANEL DETAIL SHEETS
 3. SEE ROADWAY DETAILS FOR MOUNTING OF PROPOSED SIGN PS03-02.

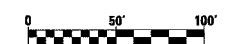

REVISIONS	
NAME	DATE

SG-03

ILLINOIS DEPARTMENT OF TRANSPORTATION
F.A.I. 90/94 (DAN RYAN EXPRESSWAY)
GARFIELD BLVD TO 31ST STREET (NB LOCAL LANES)

PROPOSED SIGNING PLANS

SCALE: 1"=50'
DATE: June 9, 2006

DRAWN BY: PHP
CHECKED BY: RMG

CTE | AECOM

F:\P\40468\CONV\NB\CONTR 18 & 19\SIGN\CONTR 18\Signing Plans\SP180303A.SHT 4:23:00 PM 6/7/2006

F.A.I.	SECTION	COUNTY	TOTAL SHEETS	SHEET NO.
94/90		COOK	565	237
STA. TO STA.		FED. ROAD DIST. NO. ILLINOIS FED. AID PROJECT		
62301		*2021-922 PT2 ETC 2324.6-1P) R-10		

I:\660\94094\WB\SHEET\SG04.DWG

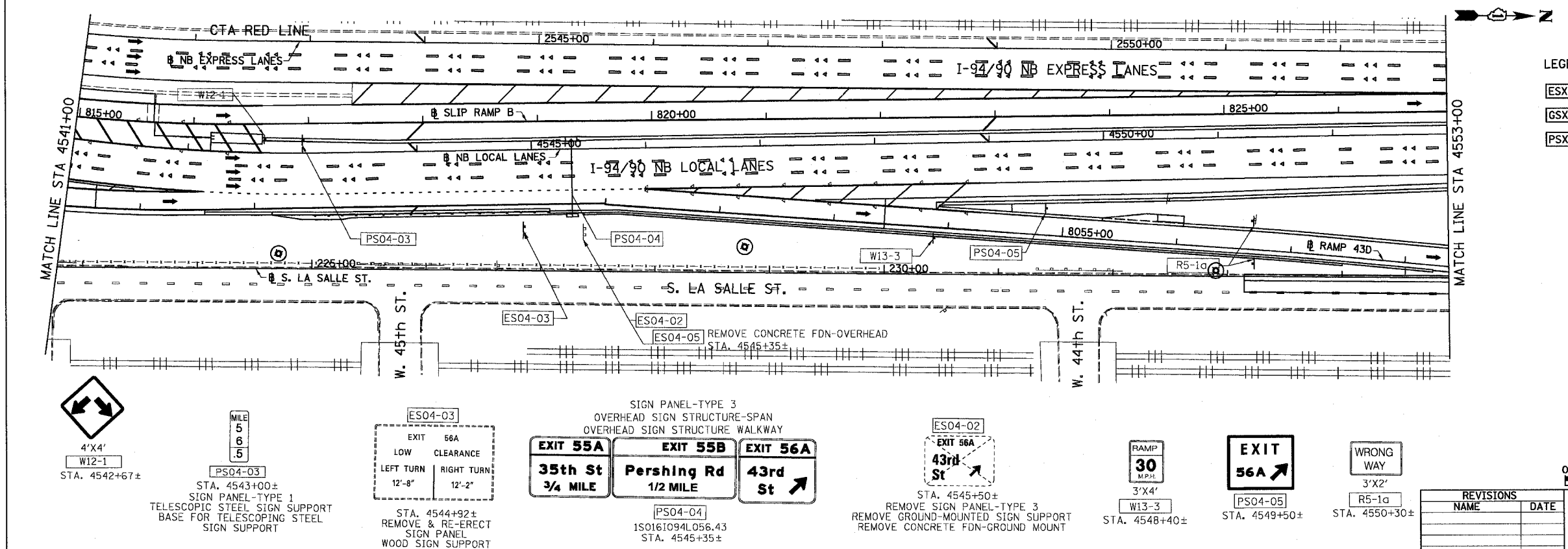
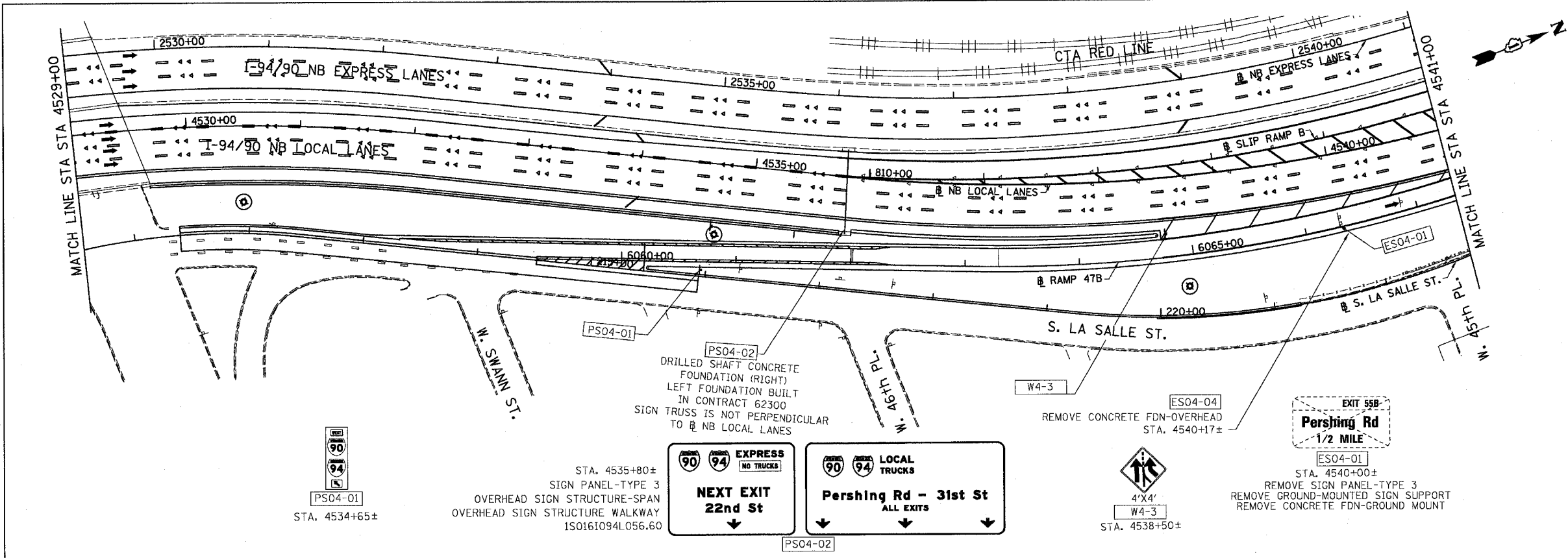

KAM ENGINEERING, INC.
CONSULTING ENGINEERS
707A Davis Road, Suite 205
Elgin, Illinois 60123-1369

PS04-03
STA. 4542+67±
SIGN PANEL-TYPE 1
TELESCOPIC STEEL SIGN SUPPORT
BASE FOR TELESCOPING STEEL
SIGN SUPPORT

ES04-03
EXIT 56A
LOW CLEARANCE
LEFT TURN 12'-8" RIGHT TURN 12'-2"
STA. 4544+92±
REMOVE & RE-ERECT
SIGN PANEL
WOOD SIGN SUPPORT

PS04-04
SIGN PANEL-TYPE 3
OVERHEAD SIGN STRUCTURE-SPAN
OVERHEAD SIGN STRUCTURE WALKWAY
STA. 4545+35±
1S0161094L056.43

ES04-02
EXIT 56A
43rd St
STA. 4545+50±
REMOVE SIGN PANEL-TYPE 3
REMOVE GROUND-MOUNTED SIGN SUPPORT
REMOVE CONCRETE FDN-GROUND MOUNT

RAMP 30
3'X4'
W13-3
STA. 4548+40±

EXIT 56A
PS04-05
STA. 4549+50±

WRONG WAY
3'X2'
R5-1a
STA. 4550+30±

REVISIONS	
NAME	DATE

ILLINOIS DEPARTMENT OF TRANSPORTATION
F.A.I. 94/90 (DAN RYAN EXPRESSWAY)
GARFIELD BLVD TO 31ST STREET (NB LOCAL LANES)

PROPOSED SIGNING PLANS

SCALE: 1"=50'
DATE: 06/09/06

DRAWN BY: RV
CHECKED BY: MSA

94531.RAI
6/27/2006

F.A.I.	SECTION	COUNTY	TOTAL SHEETS	SHEET NO.
94/90	*	COOK	565	238
STA.	TO STA.			
FED. ROAD DIST. NO.	ILLINOIS	FED. AID PROJECT		
62301	*12021-922 PT2 ETC 2324.6-1P) R-10			

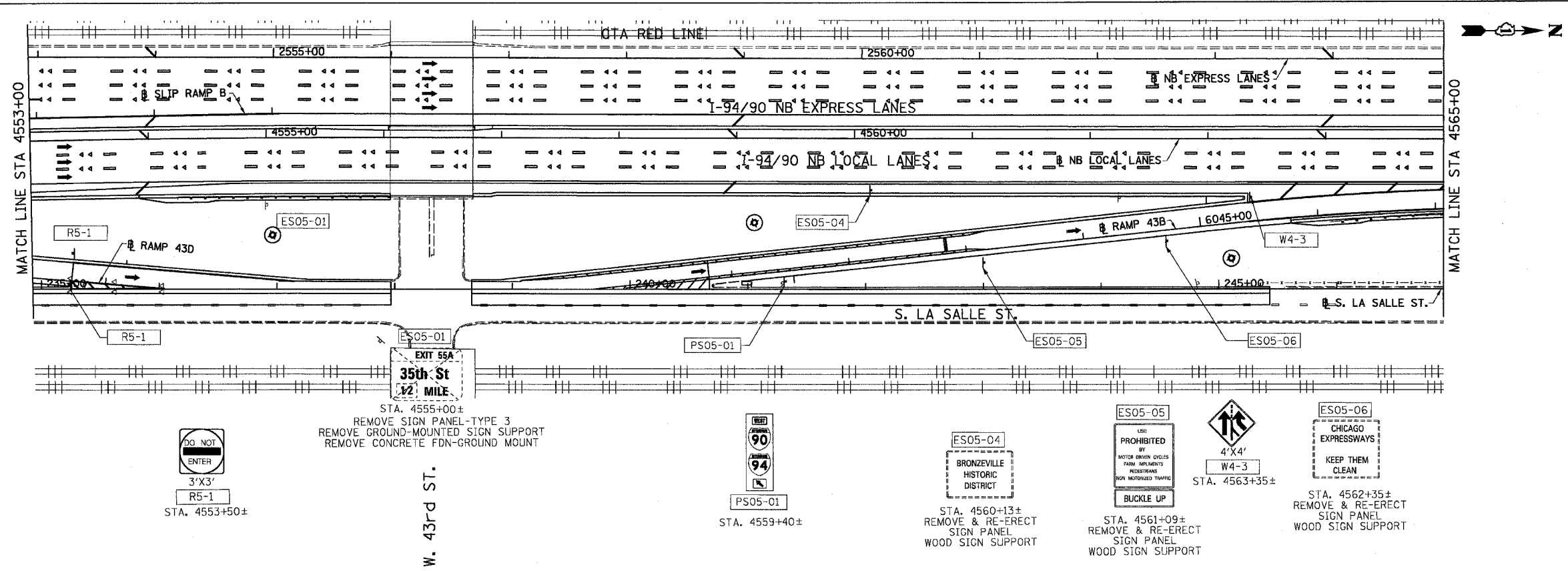

DO NOT ENTER
3'X3'
R5-1
STA. 4553+50±

STA. 4555+00±
REMOVE SIGN PANEL-TYPE 3
REMOVE GROUND-MOUNTED SIGN SUPPORT
REMOVE CONCRETE FDN-GROUND MOUNT

PS05-01
STA. 4559+40±

ES05-04
BRONZVILLE HISTORIC DISTRICT
STA. 4560+13±
REMOVE & RE-ERECT SIGN PANEL
WOOD SIGN SUPPORT

ES05-05
PROHIBITED BY MOTOR DRIVEN CYCLES FROM SURFACES REVERSELY FROM MOTORIZED TRAFFIC
BUCKLE UP
STA. 4561+09±
REMOVE & RE-ERECT SIGN PANEL
WOOD SIGN SUPPORT

4'X4'
W4-3
STA. 4563+35±

ES05-06
CHICAGO EXPRESSWAYS
KEEP THEM CLEAN
STA. 4562+35±
REMOVE & RE-ERECT SIGN PANEL
WOOD SIGN SUPPORT

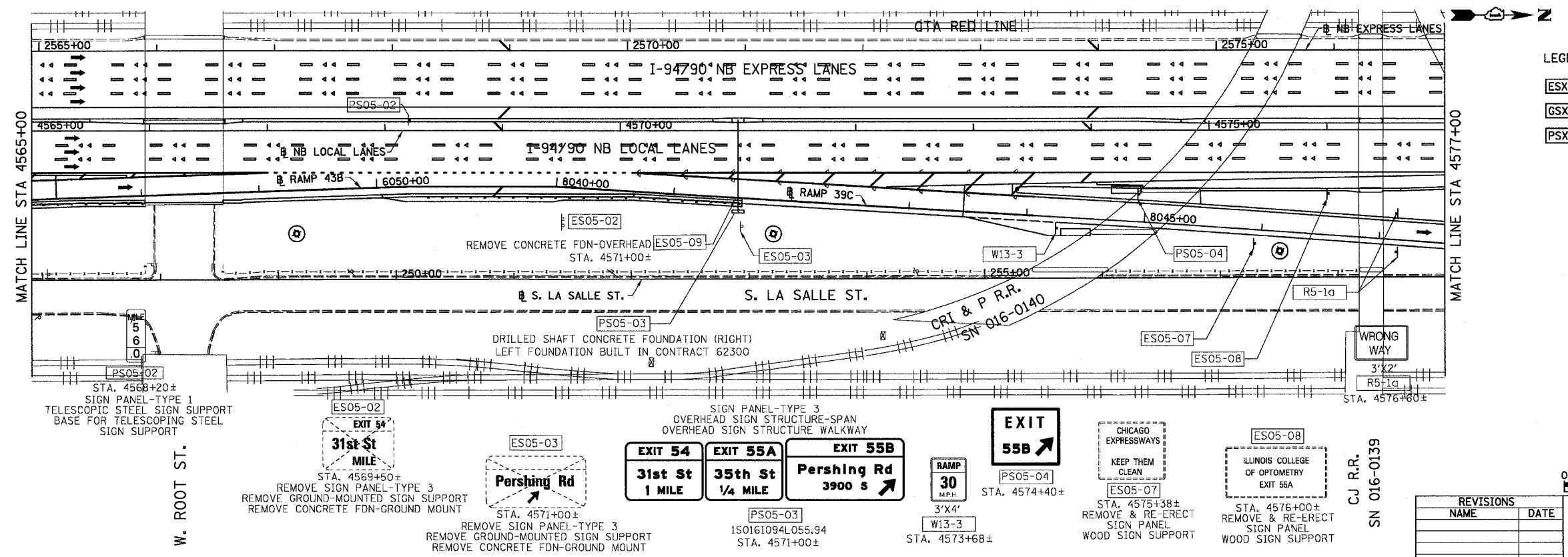

PS05-02
STA. 4568+20±
SIGN PANEL-TYPE 1
TELESCOPIC STEEL SIGN SUPPORT
BASE FOR TELESCOPIC STEEL SIGN SUPPORT

ES05-02
EXIT 54
31st St
MILE
STA. 4569+50±
REMOVE SIGN PANEL-TYPE 3
REMOVE GROUND-MOUNTED SIGN SUPPORT
REMOVE CONCRETE FDN-GROUND MOUNT

ES05-03
Pershing Rd
STA. 4571+00±
REMOVE SIGN PANEL-TYPE 3
REMOVE GROUND-MOUNTED SIGN SUPPORT
REMOVE CONCRETE FDN-GROUND MOUNT

EXIT 54
31st St
1 MILE

EXIT 55A
35th St
1/4 MILE

EXIT 55B
Pershing Rd
3900 S

RAMP
30
M.P.H.
3'X4'
W13-3
STA. 4573+68±

EXIT 55B
STA. 4574+40±

CHICAGO EXPRESSWAYS
KEEP THEM CLEAN
ES05-07
STA. 4575+38±
REMOVE & RE-ERECT SIGN PANEL
WOOD SIGN SUPPORT

ES05-08
ILLINOIS COLLEGE OF OPTOMETRY
EXIT 55A
STA. 4576+00±
REMOVE & RE-ERECT SIGN PANEL
WOOD SIGN SUPPORT

CJ R.R.
SN 016-0139

- LEGEND:
- ESXX-XX EXISTING OVERHEAD OR CANTILEVER SIGNS
 - GSXX-XX EXISTING POST MOUNTED SIGNS
 - PSXX-XX PROPOSED SIGNS

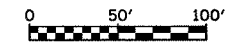

REVISIONS	
NAME	DATE

ILLINOIS DEPARTMENT OF TRANSPORTATION
F.A.I. 94/90 (DAN RYAN EXPRESSWAY)
GARFIELD BLVD TO 31ST STREET (NB LOCAL LANES)

PROPOSED SIGNING PLANS

SCALE: 1"=50'
DATE: 06/09/06

DRAWN BY: RV
CHECKED BY: MSA

K&E KAM ENGINEERING, INC.
CONSULTING ENGINEERS
707A Davis Road, Suite 205
Eglin, Illinois 60123-1369

6/28/2006 9:43:51 AM

F.A.I.	SECTION	COUNTY	TOTAL SHEETS	SHEET NO.
94/90	*	COOK	565	239
STA.		TO STA.		
FED. ROAD DIST. NO.		ILLINOIS	FED. AID PROJECT	
62301		*I2021-922 PT2 ETC 2324.6-1P) R-10		

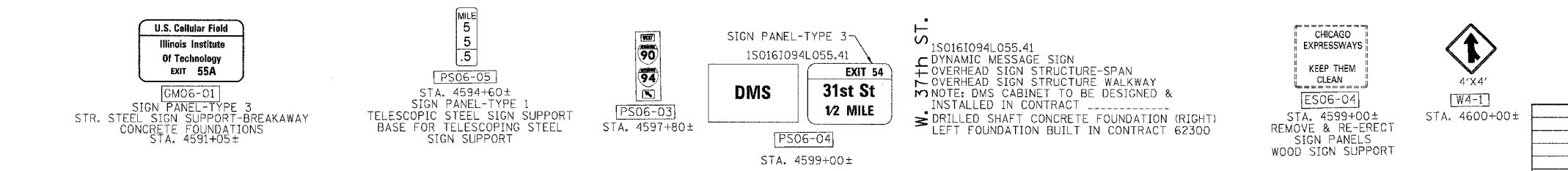
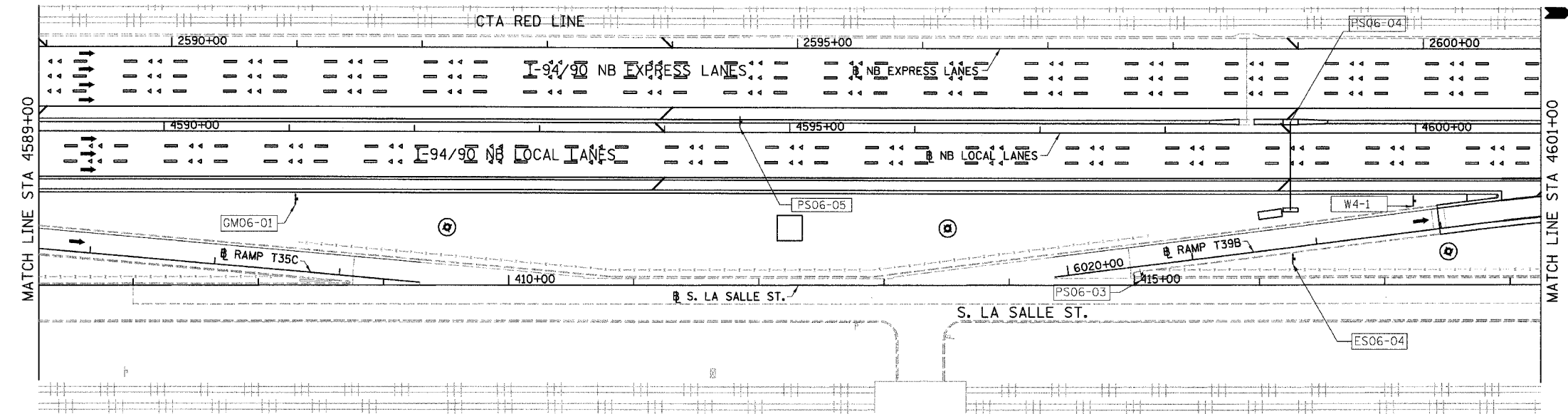
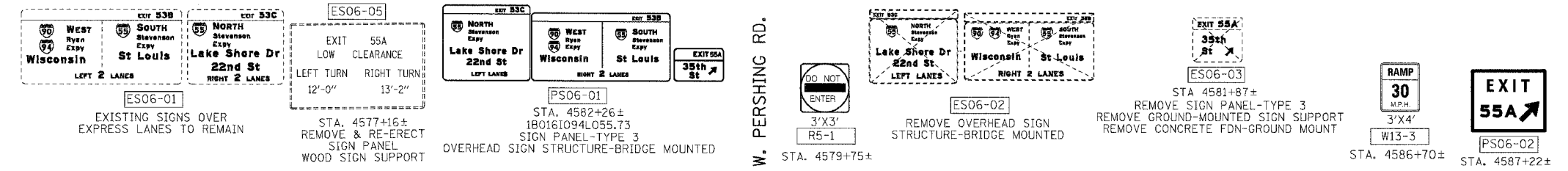
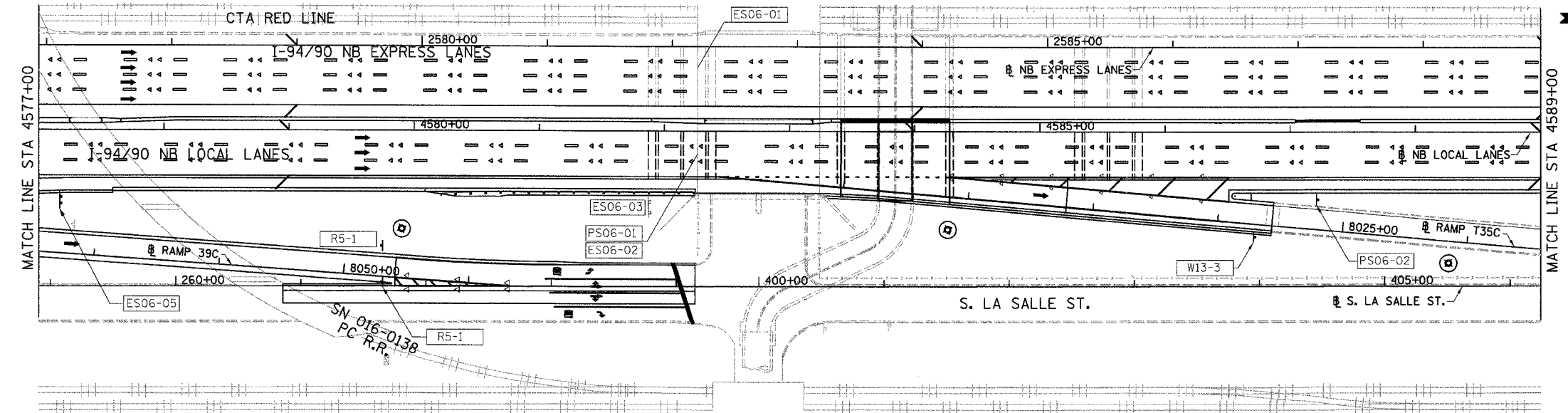

LEGEND:
ESXX-XX EXISTING OVERHEAD OR CANTILEVER SIGNS
GSXX-XX EXISTING POST MOUNTED SIGNS
PSXX-XX PROPOSED SIGNS

KAM ENGINEERING, INC.
 CONSULTING ENGINEERS
 707A Davis Road, Suite 205
 Elgin, Illinois 60123-1369

REVISIONS	
NAME	DATE

SG-06
 ILLINOIS DEPARTMENT OF TRANSPORTATION
 F.A.I. 94/90 (DAN RYAN EXPRESSWAY)
 GARFIELD BLVD TO 31ST STREET (NB LOCAL LANES)
 PROPOSED SIGNING PLANS
 SCALE: 1"=50'
 DATE: 06/09/06
 DRAWN BY: RV
 CHECKED BY: MSA

SIGN DETAIL

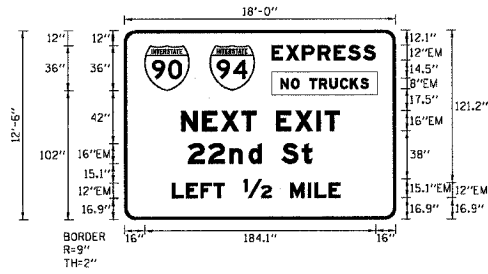

SIGN NUMBER	1S0161094L057.1 LT
WIDTH x HEIGHT	18'-0" x 12'-6"
BORDER WIDTH	2"
CORNER RADIUS	9"
MOUNTING	OVERHEAD
BACKGROUND	TYPE: REFLECTIVE
	COLOR: GREEN
LEGEND/BORDER	TYPE: REFLECTIVE
	COLOR: WHITE, BLACK

SYMBOL	X	Y	WID	HT
MI.1	16	102	35.9	36
MI.1	67.9	102	35.9	36

DIMENSIONS ARE IN INCHES, TENTHS LETTER LOCATIONS ARE PANEL EDGE TO LOWER LEFT CORNER

LETTER POSITIONS (X)										LENGTH SERIES, SIZE	
E	X	P	R	E	S	S				82.6	EM12
117.4	128.7	141.5	154.2	166.8	178.1	190.1					
N	O		T	R	U	C	K	S		70.2	EM8
124.3	132.8	139.4	147.4	154.9	163.4	171.8	179.8	188			
N	E	X	T		E	X	I	T		126	EM16
45.3	62.1	77.2	93.2	104.9	120.9	135.9	153.1	159.5			
2	2	n	d		S	+				98.6	EM16/12
50.8	66.9	83.8	99	109.2	125.2	141.4					
L	E	F	T	1/2	M	I	L	E		133.6	EM12, EM15.1
38	49.3	60.6	71	94.8	131.9	146.1	151.5	162.8			

SIGN DETAIL

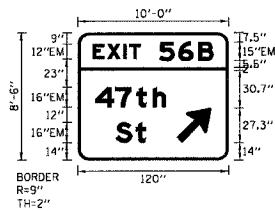

SIGN NUMBER	1S0161094L057.1 RT
WIDTH x HEIGHT	10'-0" x 8'-6"
BORDER WIDTH	2"
CORNER RADIUS	9"
MOUNTING	OVERHEAD
BACKGROUND	TYPE: REFLECTIVE
	COLOR: GREEN
LEGEND/BORDER	TYPE: REFLECTIVE
	COLOR: WHITE

SYMBOL	X	Y	WID	HT
ARMED	78.7	14	22.3	35.1

DIMENSIONS ARE IN INCHES, TENTHS LETTER LOCATIONS ARE PANEL EDGE TO LOWER LEFT CORNER

LETTER POSITIONS (X)										LENGTH SERIES, SIZE	
E	X	I	T	S	6	B				95.7	EM12, EM15
12.2	23.4	36.3	41.1	64.9	80	95.9					
4	7	t	h							56.1	EM16/12
14	29.8	46.7	59.8								
S	+									24.2	EM16/12
30	46.2										

F.A.I. RTE.	SECTION	COUNTY	TOTAL SHEETS	SHEET NO.
90/94	*	COOK	565	244
STA.	TO STA.			
FED. ROAD DIST. NO. 1 ILLINOIS FED. AID PROJECT				
62301 * (2021-922 PT2 ETC 2324.6-1P) R-10				

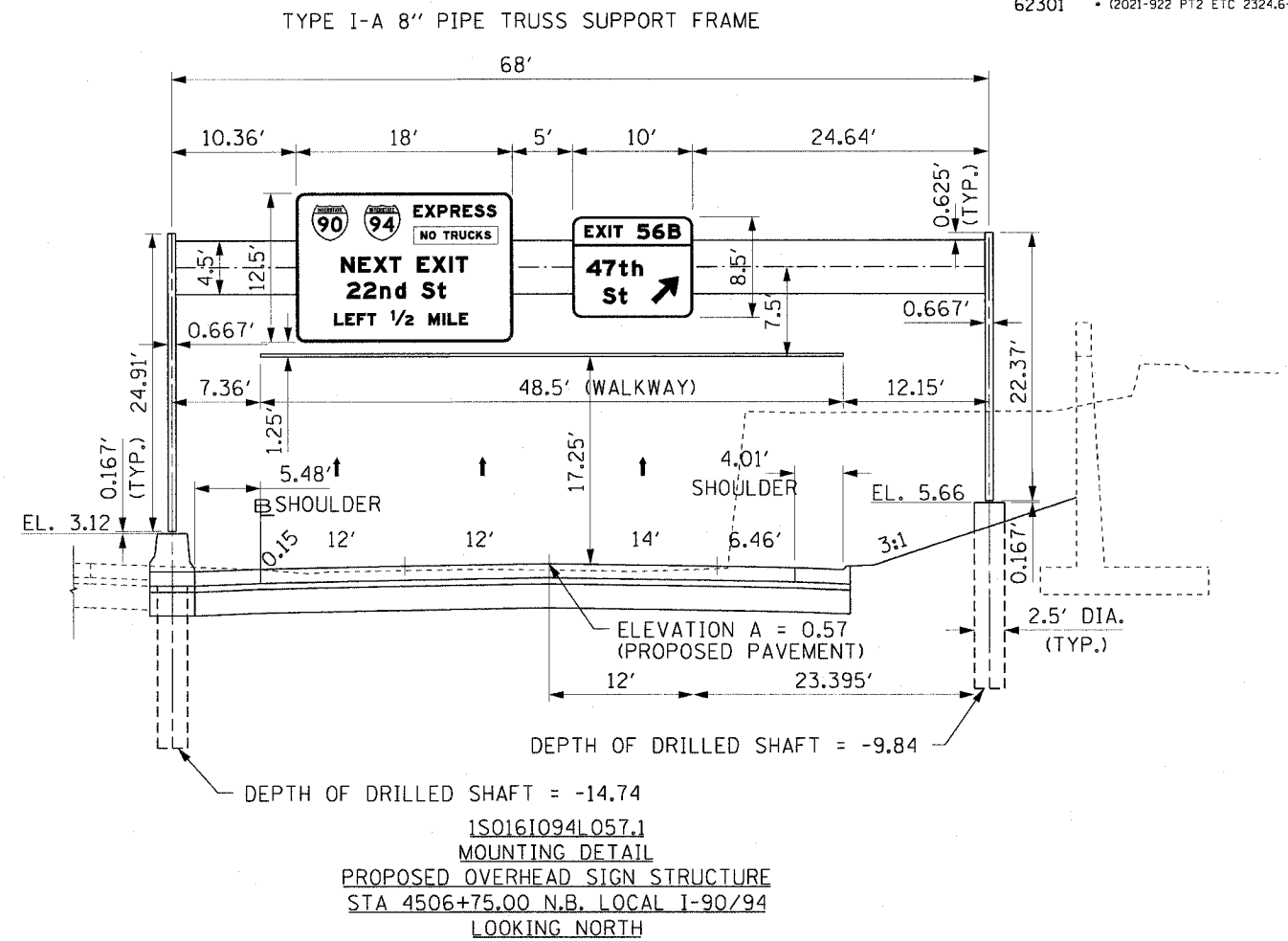

NOTES:

1. PROPOSED PAVEMENT FOR LOCAL LANES IS SHOWN FOR INFORMATION ONLY.
2. REFER TO ELECTRICAL INFRASTRUCTURE PLANS FOR ORIENTATION AND LOCATION OF THE CONDUIT EMBEDDED IN THE OVERHEAD SIGN FOUNDATIONS.

CTE | AECOM

REVISIONS	
NAME	DATE

SGN-2

ILLINOIS DEPARTMENT OF TRANSPORTATION
F.A.I. 90/94 (DAN RYAN EXPRESSWAY)
GARFIELD BLVD TO 31ST STREET (NB LOCAL LANES)

SIGN PANEL AND PLACEMENT DETAILS
PROPOSED OVERHEAD SIGN STRUCTURE
STA. 4506+75.00

SCALE: NONE DRAWN BY: JSS
DATE: June 9, 2006 CHECKED BY: RDP

P:\P\0465\CIVIL\08-Chrs 18 & 19\STA.Chtr 18\Signing\SS1800222.dwg 6/7/2006 10:21:27 AM

F.A.I. RTE.	SECTION	COUNTY	TOTAL SHEETS	SHEET NO.
90/94		COOK	565	245
STA.	TO STA.			
FED. ROAD DIST. NO. 1		ILLINOIS	FED. AID PROJECT	
62301		(2021-922 PT2 ETC 2324.6-1P) R-10		

SIGN DETAIL

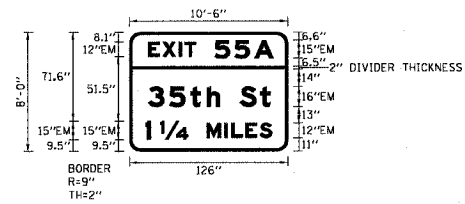

SIGN NUMBER	1S0161094RL56.9 LT
WIDTH x HEIGHT	10'-6" x 8'-0"
BORDER WIDTH	2"
CORNER RADIUS	9"
MOUNTING	OVERHEAD
BACKGROUND	TYPE: REFLECTIVE
LEGEND/BORDER	COLOR: GREEN
	TYPE: REFLECTIVE
	COLOR: WHITE

SYMBOL	X	Y	WID	HT

DIMENSIONS ARE IN INCHES, TENTHS LETTER LOCATIONS ARE PANEL EDGE TO LOWER LEFT CORNER

LETTER POSITIONS (X)										LENGTH SERIES, SIZE		
E	X	I	T	S	S	A						
15.2	26.4	39.3	44.1	67.9	83.7	99.6				99.4	EM12, EM15	
3	5	t	h	S	t					97.3	EM16/12	
14.9	31.7	48.7	61.7	72	88	104.1						
1	1/4	M	I	L	E	S				100.9	EM15, EM12	
12.6	24.5	61.5	75.6	81.1	92.4	103.6						

SIGN DETAIL

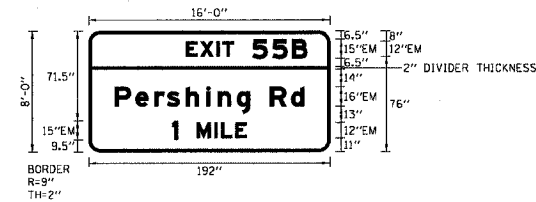

SIGN NUMBER	1S0161094L056.9
WIDTH x HEIGHT	16'-0" x 8'-0"
BORDER WIDTH	2"
CORNER RADIUS	9"
MOUNTING	OVERHEAD
BACKGROUND	TYPE: REFLECTIVE
LEGEND/BORDER	COLOR: GREEN
	TYPE: REFLECTIVE
	COLOR: WHITE

SYMBOL	X	Y	WID	HT

DIMENSIONS ARE IN INCHES, TENTHS LETTER LOCATIONS ARE PANEL EDGE TO LOWER LEFT CORNER

LETTER POSITIONS (X)										LENGTH SERIES, SIZE		
E	X	I	T	S	S	B						
77.6	88.9	101.7	106.5	130.3	146.1	162				96.4	EM12, EM15	
P	e	r	s	h	l	i	n	g	R	d		
20.6	37.2	52.4	62.3	77.3	93.6	102.9	118	128.3	144.3	161.2		150.8
1	M	I	L	E								59.1
66.4	85.9	100	105.4	116.7								

TYPE II-A 10" PIPE TRUSS SUPPORT FRAME

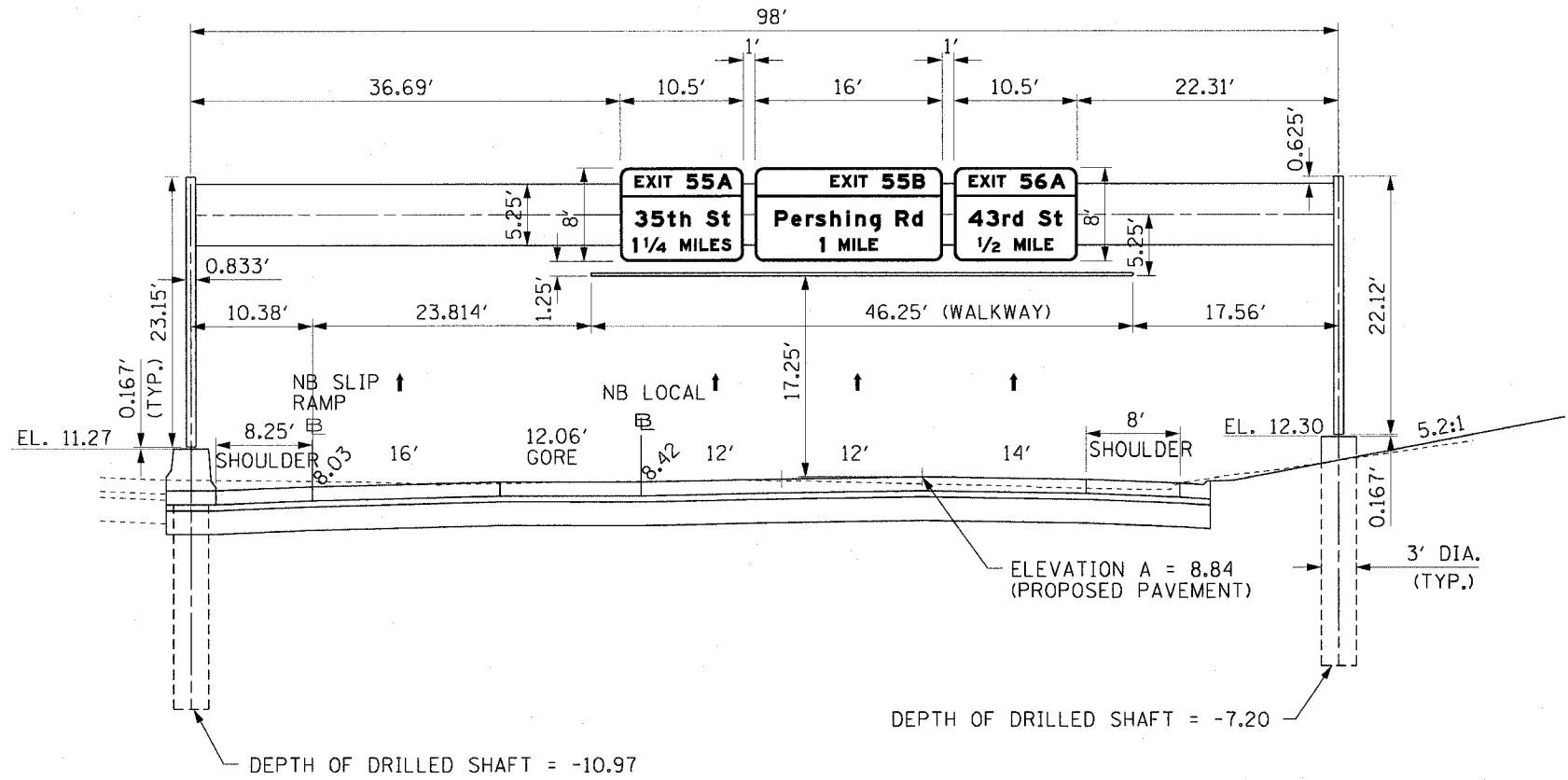

1S0161094L056.9
MOUNTING DETAIL
PROPOSED OVERHEAD SIGN STRUCTURE
STA 4518+40.00 N.B. LOCAL I-90/94
LOOKING NORTH

NOTES:

1. PROPOSED PAVEMENT FOR LOCAL LANES IS SHOWN FOR INFORMATION ONLY.
2. REFER TO ELECTRICAL INFRASTRUCTURE PLANS FOR ORIENTATION AND LOCATION OF THE CONDUIT EMBEDDED IN THE OVERHEAD SIGN FOUNDATIONS.

REVISIONS		ILLINOIS DEPARTMENT OF TRANSPORTATION F.A.I. 90/94 (DAN RYAN EXPRESSWAY) GARFIELD BLVD TO 31ST STREET (NB LOCAL LANES)
NAME	DATE	

SIGN PANEL AND PLACEMENT DETAILS
PROPOSED OVERHEAD SIGN STRUCTURE
STA. 4518+40.00

SCALE: NONE DRAWN BY: JSS
DATE: June 9, 2006 CHECKED BY: RDP

F.A.I. RTE.	SECTION	COUNTY	TOTAL SHEETS	SHEET NO.
94/90	*	COOK	565	246

STA. TO STA.
 ILLINOIS FED. AID PROJECT
 * 62301 (2021-922 PT2 ETC 2324.6-1P) R-10

SIGN NUMBER	1S016I094L056.43 LT
WIDTH x HGHT.	12'-0" x 8'-6"
BORDER WIDTH	2"
CORNER RADIUS	9"
MOUNTING	Overhead
BACKGROUND	TYPE: Reflective COLOR: Green
LEGEND/BORDER	TYPE: Reflective COLOR: White

SYMBOL	X	Y	WID	HT

SIGN DETAIL
1:100

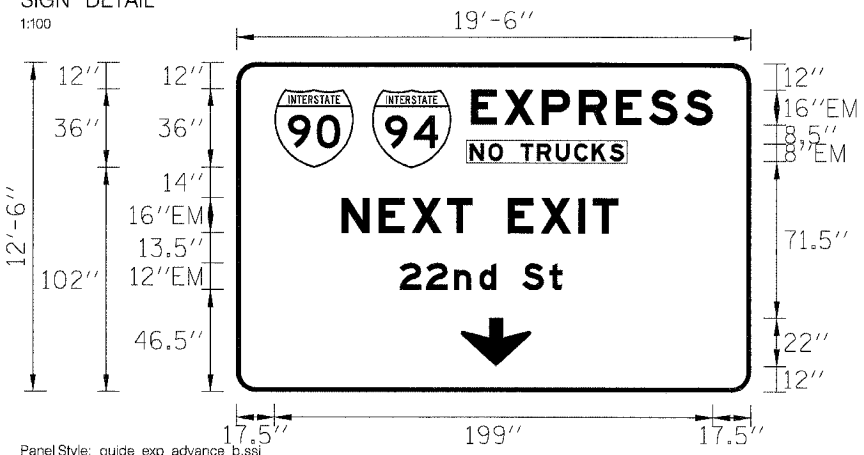

SIGN NUMBER	1S016I094L056.60
WIDTH x HGHT.	19'-6" x 12'-6"
BORDER WIDTH	2"
CORNER RADIUS	9"
MOUNTING	Overhead
BACKGROUND	TYPE: Reflective COLOR: Green
LEGEND/BORDER	TYPE: Reflective COLOR: White

SYMBOL	X	Y	WID	HT
MI_1	17.5	102	36	36
MI_1	61.7	102	36	36
AROWDOWN	101	12	32	22

Panel Style: guide_exp_advance_b.ssi
 Dimensions are in inches.tenths Letter locations are panel edge to lower left corner

LETTER POSITIONS (X)										LENGTH	SERIESIZE
E	X	P	R	E	S	S				110	EM16
106.7	121.7	138.8	155.7	172.6	187.6	203.7					
N	O		T	R	U	C	K	S		70.2	EM8
106.1	114.5	121.2	129.2	136.7	145.1	153.6	161.6	169.7			
N	E	X	T		E	X	I	T		126	EM16
47.7	64.6	79.6	95.6	107.4	123.4	138.4	155.5	162			
2	2	n	d		S	t				74	EM129
74.3	86.4	99.1	110.4	118.1	130.1	142.2					

SIGN DETAIL
1:75

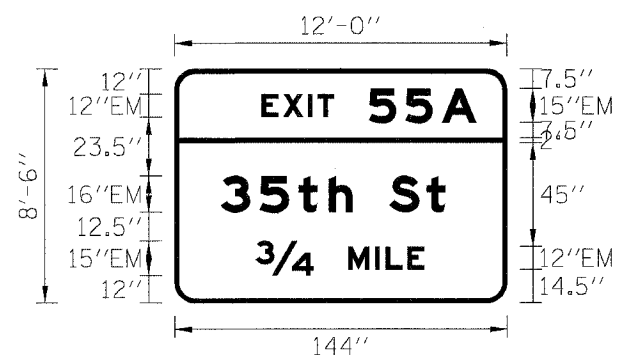

Dimensions are in inches.tenths Letter locations are panel edge to lower left corner

LETTER POSITIONS (X)										LENGTH	SERIESIZE
E	X	I	T	5	5	A				93.1	EM12,EM15
37.7	47.1	57.8	61.8	84.2	100	115.8					
3	5	t	h		S	t				97.3	EM16/12
20	36.9	53.8	66.8	77.1	93.1	109.2					
3/4	M	I	L	E						73	EM15,EM12
35.1	75.1	86.9	91.4	100.8							

SIGN DETAIL
1:100

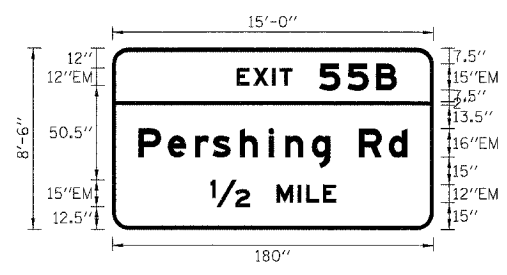

SIGN NUMBER	1S016I094L056.43 CN
WIDTH x HGHT.	15'-0" x 8'-6"
BORDER WIDTH	2"
CORNER RADIUS	9"
MOUNTING	Overhead
BACKGROUND	TYPE: Reflective COLOR: Green
LEGEND/BORDER	TYPE: Reflective COLOR: White

SYMBOL	X	Y	WID	HT

Panel Style: guide_exp_advance_b.ssi
 Dimensions are in inches.tenths Letter locations are panel edge to lower left corner

LETTER POSITIONS (X)										LENGTH	SERIESIZE
E	X	I	T	5	5	B				90.1	EM12,EM15
69.5	78.9	89.6	93.6	116	131.8	147.7					
P	e	r	s	h	i	n	g	R	d	150.8	EM16/12
14.5	31.1	46.4	56.2	71.3	87.6	96.8	112	122.2	138.2		
1/2	M	I	L	E						70.5	EM15,EM12
54.9	92.1	103.9	108.5	118							

SIGN DETAIL
1:100

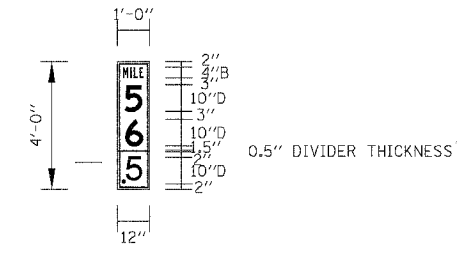

SIGN NUMBER	PS04-03
WIDTH x HGHT.	1'-0" x 4'-0"
BORDER WIDTH	0.5"
CORNER RADIUS	1.5"
MOUNTING	Barrier
BACKGROUND	TYPE: Reflective COLOR: Green
LEGEND/BORDER	TYPE: Reflective COLOR: White

SYMBOL	X	Y	WID	HT

Panel Style: guide_exp_distance.ssi
 Dimensions are in inches.tenths Letter locations are panel edge to lower left corner

LETTER POSITIONS (X)										LENGTH	SERIESIZE
M	I	L	E							7.5	B4
2.1	4.8	6	8.1								
5										6.8	D10
2.6											
6										6.8	D10
2.9											
1.8										1.5	D10
5										6.8	D10
3.5											

REVISIONS	
NAME	DATE

ILLINOIS DEPARTMENT OF TRANSPORTATION
 F.A.I. 90/94 (DAN RYAN EXPRESSWAY)
 GARFIELD BLVD TO 31ST STREET (NB LOCAL LANES)
 SIGN PANEL DETAILS

SCALE: NONE
 DATE: 06/09/06
 DRAWN BY: RV
 CHECKED BY: AS

F.A.I. RTE.	SECTION	COUNTY	TOTAL SHEETS	SHEET NO.
94/90	*	COOK	565	247
STA.		TO STA.		
FED. ROAD DIST. NO.		ILLINOIS FED. AID PROJECT		

* 62301 (2021-922 PT2 ETC 2324.6-1P) R-10

SIGN DETAIL
1:100

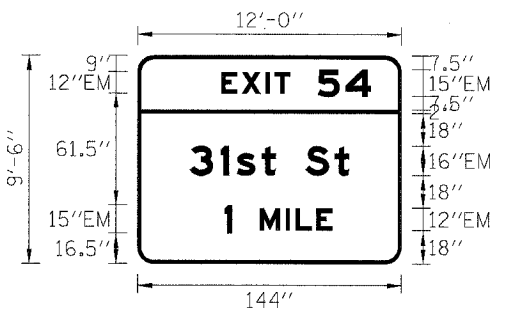

SIGN NUMBER	1S016I094L055.94 LT
WIDTH x HGHT.	12'-0" x 9'-6"
BORDER WIDTH	2"
CORNER RADIUS	9"
MOUNTING	Overhead
BACKGROUND	TYPE: Reflective COLOR: Green
LEGEND/BORDER	TYPE: Reflective COLOR: White

SYMBOL	X	Y	WID	HT

Panel Style: guide_exp_advance_b.ssi
Dimensions are in inches.tenths

Letter locations are panel edge to lower left corner

LETTER POSITIONS (X)										LENGTH	SERIES/SIZE
E	X	I	T	5	4					EM12,EM15	
45.5	56.8	69.6	74.5	98.3	113.4					81.8	
3	1	s	t		S	t				EM16/12	
28.4	45.2	54.1	67.4	75.5	91.4	107.6				87.3	
1	M	I	L	E						EM15,EM12	
47.2	66.6	80.8	86.2	97.5						59.1	

SIGN DETAIL
1:100

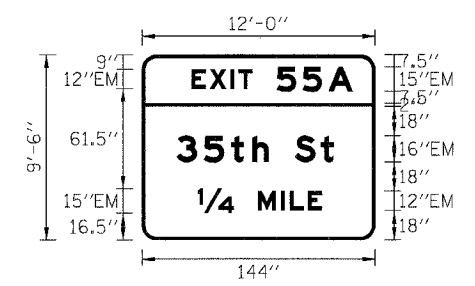

SIGN NUMBER	1S016I094L055.94 CN
WIDTH x HGHT.	12'-0" x 9'-6"
BORDER WIDTH	2"
CORNER RADIUS	9"
MOUNTING	Overhead
BACKGROUND	TYPE: Reflective COLOR: Green
LEGEND/BORDER	TYPE: Reflective COLOR: White

SYMBOL	X	Y	WID	HT

Panel Style: guide_exp_advance_b.ssi
Dimensions are in inches.tenths

Letter locations are panel edge to lower left corner

LETTER POSITIONS (X)										LENGTH	SERIES/SIZE
E	X	I	T	5	5	A				EM12,EM15	
30.5	41.8	54.6	59.5	83.3	99.2	115.2				99.8	
3	5	t	h		S	t				EM16/12	
21.2	38.1	55	68.1	78.3	94.3	110.4				97.3	
1	M	I	L	E						EM15,EM12	
34.5	71.6	85.8	91.2	102.5						76.8	

SIGN DETAIL
1:100

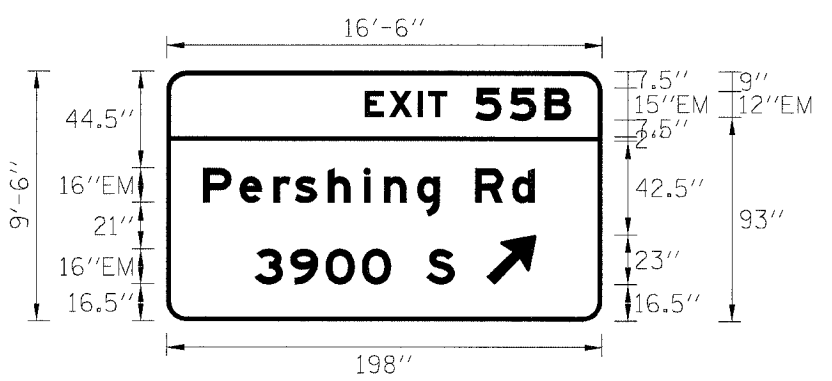

SIGN NUMBER	1S016I094L055.94 RT
WIDTH x HGHT.	16'-6" x 9'-6"
BORDER WIDTH	2"
CORNER RADIUS	9"
MOUNTING	Overhead
BACKGROUND	TYPE: Reflective COLOR: Green
LEGEND/BORDER	TYPE: Reflective COLOR: White

SYMBOL	X	Y	WID	HT
ARMED	145.5	16.5	18.5	29.2

Panel Style: guide_exp_advance_b.ssi
Dimensions are in inches.tenths

Letter locations are panel edge to lower left corner

LETTER POSITIONS (X)										LENGTH	SERIES/SIZE
E	X	I	T	5	5	B				EM12,EM15	
89.9	101.2	114	118.9	140.3	156.1	171.9				94	
P	e	r	s	h	i	n	g		R	d	EM16/12
16.5	33.1	48.4	59.2	73.3	89.6	98.8	114	124.2	140.2	157.1	150.8
3	9	0	0	S							EM16
40.1	56.1	72.2	88.8	102	118						91

SIGN DETAIL
1:75

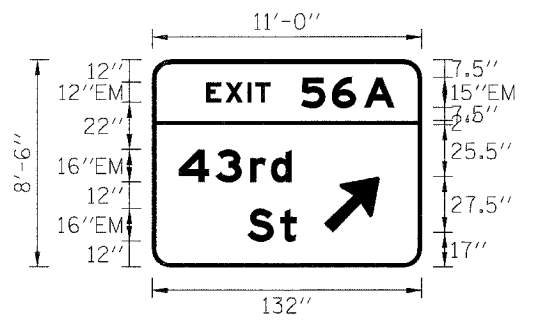

SIGN NUMBER	1S016I094L056.43 RT
WIDTH x HGHT.	11'-0" x 8'-6"
BORDER WIDTH	2"
CORNER RADIUS	9"
MOUNTING	Overhead
BACKGROUND	TYPE: Reflective COLOR: Green
LEGEND/BORDER	TYPE: Reflective COLOR: White

SYMBOL	X	Y	WID	HT
ARMED	84.2	18	22.3	35.1

Dimensions are in inches.tenths

Letter locations are panel edge to lower left corner

LETTER POSITIONS (X)										LENGTH	SERIES/SIZE
E	X	I	T	5	6	B				EM12,EM15	
26.4	35.8	46.4	50.5	72.8	87.9	103.8				89.4	
4	3	r	d							EM16/12	
12.9	31	47.9	58.1							55.4	
S	t									EM16/12	
46.5	62.6									24.2	

REVISIONS	
NAME	DATE

ILLINOIS DEPARTMENT OF TRANSPORTATION
F.A.I. 90/94 (DAN RYAN EXPRESSWAY)
GARFIELD BLVD TO 31ST STREET (NB LOCAL LANES)
SIGN PANEL DETAILS

SCALE: NONE
DATE: 06/09/06

RV
CHECKED BY: AS



SGN-05

6/7/2006

F.A.I. RTE.	SECTION	COUNTY	TOTAL SHEETS	SHEET NO.
94/90	*	COOK	565	248
STA.		TO STA.		
FED. ROAD DIST. NO.		ILLINOIS FED. AID PROJECT		
* 62301 (2021-922 PT2 ETC 2324.6-1P) R-10				

SIGN DETAIL
1:100

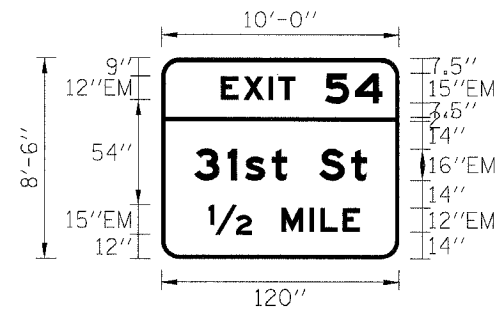

SIGN NUMBER	1S016I094L055.41 RT
WIDTH x HGHT.	10'-0" x 8'-6"
BORDER WIDTH	2"
CORNER RADIUS	9"
MOUNTING	Overhead
BACKGROUND	TYPE: Reflective COLOR: Green
LEGEND/BORDER	TYPE: Reflective COLOR: White

SYMBOL	X	Y	WID	HT

Panel Style: guide_exp_advance_b.ssi
Dimensions are in inches.tenths

Letter locations are panel edge to lower left corner

LETTER POSITIONS (X)										LENGTH	SERIES/SIZE
E	X	I	T	5	4					81.7	EM12,EM15
29.9	41.2	54	58.9	82.7	97.7						
3	1	s	t		S	t				87.3	EM16/12
16.4	33.3	42.2	55.5	63.5	79.5	95.6					
12	M	I	L	E						76.6	EM15,EM12
23.6	60.5	74.7	80.1	91.4							

SIGN DETAIL
1:100

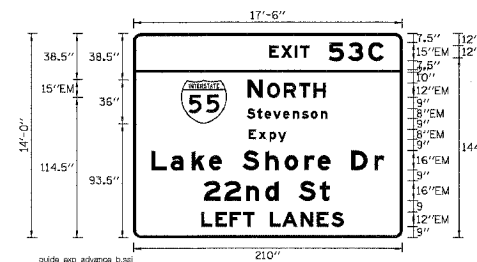

SIGN NUMBER	1B016I094L055.73 LT
WIDTH x HGHT.	17'-6" x 14'-0"
BORDER WIDTH	2"
CORNER RADIUS	9"
MOUNTING	Overhead
BACKGROUND	TYPE: Reflective COLOR: Green
LEGEND/BORDER	TYPE: Reflective COLOR: White

SYMBOL	X	Y	WID	HT
M1_1	37	93.4	36	36

Panel Style: guide_exp_advance_b.ssi
Dimensions are in inches.tenths

Letter locations are panel edge to lower left corner

LETTER POSITIONS (X)										LENGTH	SERIES/SIZE
E	X	I	T	5	3	C				89.4	EM10,EM15
106.1	115.5	126.2	130.2	152.5	167.6	183.5					
N	O	R	T	H						61.3	EM15,EM12
89	104.4	117.4	129.5	140.8							
S	t	e	v	e	n	s	o	n		62.9	EM86
88.6	96.6	102.5	109.3	116.8	124.4	131.8	138.6	146.3			
E	x	p	y							29.6	EM86
89.9	97.7	106.3	112.9								
L	a	k	e		S	h	o	r	e	182.1	EM16/12
14	29	45.3	58.9	69.2	85.2	103.1	118.2	133.7	143.8		
2	2	n	d		S	t				98.6	EM16/12
54.8	70.9	87.9	103	113.3	129.2	145.4					
L	E	F	T		L	A	N	E	S	111.7	EM12
52.7	64	75.3	85.7	94.5	106.5	116.2	130.7	143.3	154.6		

SIGN DETAIL
1:75

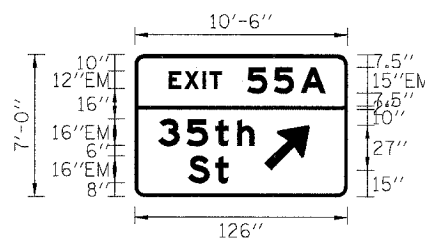

SIGN NUMBER	1B016I094L055.73 RT
WIDTH x HGHT.	10'-6" x 7'-0"
BORDER WIDTH	2"
CORNER RADIUS	9"
MOUNTING	Overhead
BACKGROUND	TYPE: Reflective COLOR: Green
LEGEND/BORDER	TYPE: Reflective COLOR: White

SYMBOL	X	Y	WID	HT
ARMED	76.7	15.6	22	34.6

Panel Style: guide_exp_advance_b.ssi
Dimensions are in inches.tenths

Letter locations are panel edge to lower left corner

LETTER POSITIONS (X)										LENGTH	SERIES/SIZE
E	X	I	T	5	5	A				93.1	EM12,EM15
20.1	29.5	40.2	44.3	66.6	82.4	98.3					
3	5	t	h							57.1	EM16/12
13.8	30.7	47.6	60.7								
S	t									24.2	EM16/12
31.4	47.6										

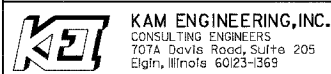

REVISIONS		ILLINOIS DEPARTMENT OF TRANSPORTATION F.A.I. 90/94 (DAN RYAN EXPRESSWAY) GARFIELD BLVD TO 31ST STREET (NB LOCAL LANES) SIGN PANEL DETAILS
NAME	DATE	

SCALE: NONE
DATE: 06/09/06

DRAWN BY: RV
CHECKED BY: AS

SGN-06

6/7/2006 1:50:22 PM

F.A.I. RTE.	SECTION	COUNTY	TOTAL SHEETS	SHEET NO.
94/90	*	COOK	565	249
STA.		TO STA.		
FED. ROAD DIST. NO.	ILLINOIS	FED. AID PROJECT		
* 62301 (2021-922 PT2 ETC 2324.6-1P) R-10				

SIGN DETAIL
1:100

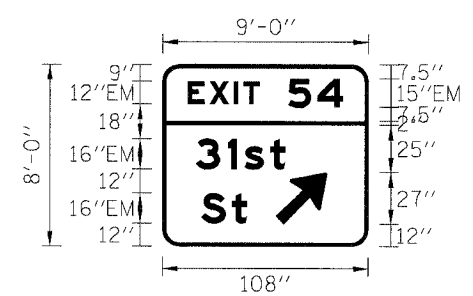

SIGN NUMBER	1B016I094L054.97 RT
WIDTH x HGHT.	9'-0" x 8'-0"
BORDER WIDTH	2"
CORNER RADIUS	9"
MOUNTING	Overhead
BACKGROUND	TYPE: Reflective COLOR: Green
LEGEND/BORDER	TYPE: Reflective COLOR: White

SYMBOL	X	Y	WID	HT
ARMED	59.2	12	22.3	35.1

Panel Style: guide_exp_advance_b.ssi
Dimensions are in inches.tenths

Letter locations are panel edge to lower left corner

LETTER POSITIONS (X)										LENGTH	SERIES/SIZE
E	X	I	T	S	4					81.7	EM12,EM15
13.2	24.5	37.3	42.1	65.9	81						
3	1	s	t							47.1	EM16/12
17.3	34.2	43.1	56.4								
S	t									24.2	EM16/12
20.1	36.3										

SIGN DETAIL

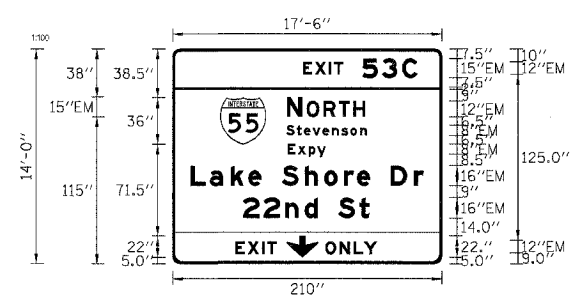

SIGN NUMBER	1B016I094L054.97 LT
WIDTH x HGHT.	17'-6" x 14'-0"
BORDER WIDTH	2"
CORNER RADIUS	9"
MOUNTING	Overhead
BACKGROUND	TYPE: Reflective COLOR: Green/Yellow
LEGEND/BORDER	TYPE: Reflective COLOR: White /Black

SYMBOL	X	Y	WID	HT
M1_1	97	98.5	36	36
ARDDOWN	102	5	32	22

Panel Style: guide_exp_advance_b.ssi
Dimensions are in inches.tenths

Letter locations are panel edge to lower left corner

LETTER POSITIONS (X)										LENGTH	SERIES/SIZE			
E	X	I	T	S	3	C				89.4	EM10,EM15			
101.7	111.1	121.7	125.8	148.1	163.2	179.1								
N	O	R	T	H						61.3	EM15,EM12			
89	104.4	117.4	129.5	140.8										
S	t	e	v	e	n	s	o	n		62.9	EM8/6			
88.6	96.6	102.5	109.3	116.8	124.4	131.8	138.6	146.3						
E	x	p	y							29.5	EM8/6			
89.9	97.7	106.3	112.9											
L	a	k	e	S	h	o	r	e	D	r	182.1	EM16/12		
14	29	45.3	58.9	69.2	85.2	103.1	116.2	133.7	143.9	154.1	170.1	188.2		
2	2	n	d	S	t								98.6	EM16/12
54.8	70.9	87.9	103	113.3	129.3	145.4								
E	X	I	T	O	N	L	Y						80.6	EM12
64.6	74	84.7	88.5	95.9	105.9	116.7	127.3	135.3						

SIGN DETAIL
1:100

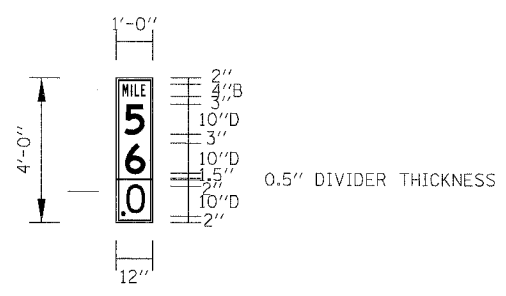

SIGN NUMBER	PS05-02
WIDTH x HGHT.	1'-0" x 4'-0"
BORDER WIDTH	0.5"
CORNER RADIUS	1.5"
MOUNTING	Barrier
BACKGROUND	TYPE: Reflective COLOR: Green
LEGEND/BORDER	TYPE: Reflective COLOR: White

SYMBOL	X	Y	WID	HT

Panel Style: guide_exp_distance.ssi
Dimensions are in inches.tenths

Letter locations are panel edge to lower left corner

LETTER POSITIONS (X)					LENGTH	SERIES/SIZE
M	I	L	E		7.5	B4
2.1	4.8	6	8.1			
5					6.8	D10
2.6						
6					6.8	D10
2.9						
.					1.5	D10
0					6.8	D10
3.5						

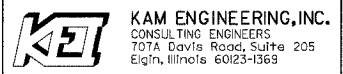

REVISIONS	
NAME	DATE

ILLINOIS DEPARTMENT OF TRANSPORTATION
F.A.I. 90/94 (DAN RYAN EXPRESSWAY)
GARFIELD BLVD TO 31ST STREET (NB LOCAL LANES)
SIGN PANEL DETAILS-1
SCALE: NONE
DATE: 06/09/06
DRAWN BY: RV
CHECKED BY: AS

SGN-07

6/7/2006 15:02:23 PM

SIGN DETAIL
1:100

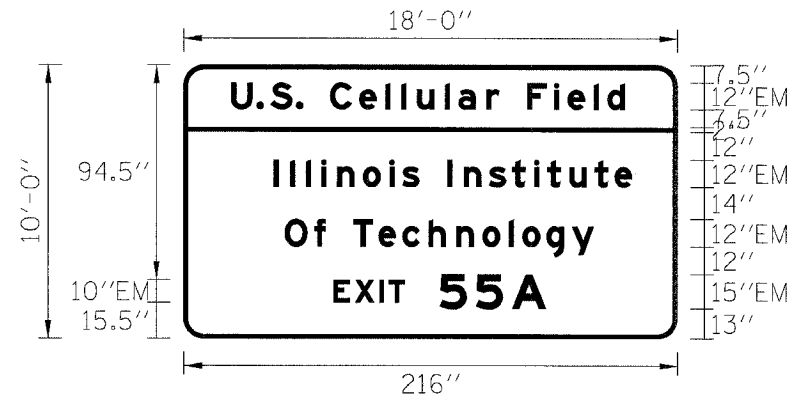

SIGN NUMBER	4591+05
WIDTH x HIGHT.	18'-0" x 10'-0"
BORDER WIDTH	2"
CORNER RADIUS	9"
MOUNTING	Ground Mount
BACKGROUND	TYPE: Reflective COLOR: Green
LEGEND/BORDER	TYPE: Reflective COLOR: White

SYMBOL	X	Y	WID	HT

Panel Style: guide_exp_advance_b.ssi
Dimensions are in inches.tenths

Letter locations are panel edge to lower left corner

LETTER POSITIONS (X)																	LENGTH	SERIES/SIZE	
U	.	S	.	C	e	l	l	u	l	a	r	.	F	i	e	l	d		EM129
20.6	31.7	37.8	49	52	64	76.8	88.2	95.1	101.9	114.2	120.1	132.4	138.2	150.2	162	168	179.4	185.3	172.4
I	I	I	I	n	o	i	s	.	I	n	s	t	i	t	u	t	e		EM129
39.3	46.5	53.4	60.1	67.1	78.4	89.9	95.6	103.3	115.3	122.5	133.6	143.5	153.2	159	168.7	179.8	188.5		157
O	f	.	T	e	c	h	n	o	l	o	g	y							EM129
44.3	57.2	62.1	74.1	85.2	95.7	107.1	119.4	130.7	142.3	148.2	158.8	169.8							135.3
E	X	I	T	S	S	A													EM10,EM15
65.5	74.9	85.6	89.7	112	127.8	143.7													93.1

F.A.I. RTE.	SECTION	COUNTY	TOTAL SHEETS	SHEET NO.
94/90	*	COOK	565	251
STA.	TO STA.			
FED. ROAD DIST. NO.	ILLINOIS	FED. AID PROJECT		

* 62301 (2021-922 PT2 ETC 2324.6-1P) R-10

SIGN NUMBER	1B718094L054.07 CN 1B016094L054.72 RT
WIDTH x HIGHT.	23'-0" x 14'-0"
BORDER WIDTH	2"
CORNER RADIUS	9"
MOUNTING	Overhead
BACKGROUND	TYPE: Reflective COLOR: Green
LEGEND/BORDER	TYPE: Reflective COLOR: White

SYMBOL	X	Y	WID	HT
M1_1	20.7	93.2	36	36
M1_1	148.4	93.1	36	36
M1_1	20.4	53.4	36	36
AR/DOWN	54	6	32	22
AR/DOWN	210	6	32	22

SIGN DETAIL
1:100

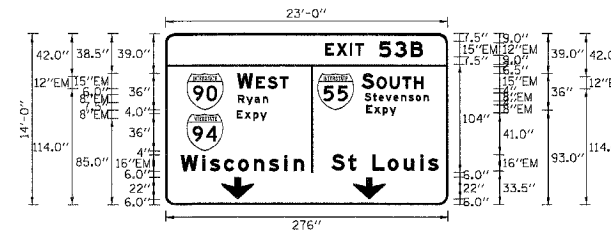

Panel Style: guide_exp_advance_b.ssi
Dimensions are in inches.tenths

Letter locations are panel edge to lower left corner

LETTER POSITIONS (X)																	LENGTH	SERIES/SIZE	
E	X	I	T	S	S	A													EM12,EM15
150.2	167.5	180.3	185.1	208.9	224	239.9													95.7
W	E	S	T																EM15,EM12
69.9	88.4	89.7	111.7																50.7
S	O	U	T	H															EM15,EM12
191.6	206.4	219.4	231.4	242.7															80.7
S	t	e	v	e	n	s	o	n											EM86
194.6	202.6	208.5	215.3	222.8	230.4	237.8	244.6	252.3	257.5									63.5	
R	y	a	n																EM86
70.7	78.9	86.9	95.1																29.6
E	x	p	y																EM86
196	203.9	212.4	219.1																29.6
E	x	p	y																EM86
89.5	77.3	85.9	92.5																29.5
W	i	s	c	o	n	s	i	n											EM1612
14.8	35.7	43.3	57	70.9	86.3	101.1	116	125.3											120.7
S	.	L	o	u	i	s													EM1612
182.2	178.3	186.3	202.3	217.3	232.8	249.1	258.7												104.7

SIGN DETAIL
1:100

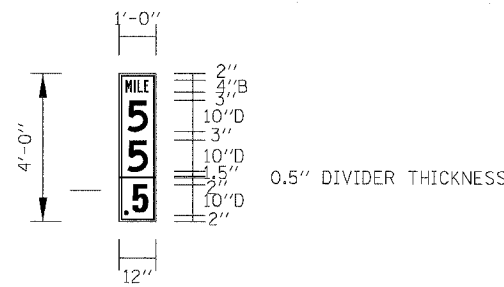

SIGN NUMBER	PS06-05
WIDTH x HIGHT.	1'-0" x 4'-0"
BORDER WIDTH	0.5"
CORNER RADIUS	1.5"
MOUNTING	Barrier
BACKGROUND	TYPE: Reflective COLOR: Green
LEGEND/BORDER	TYPE: Reflective COLOR: White

SYMBOL	X	Y	WID	HT

Panel Style: guide_exp_distance.ssi
Dimensions are in inches.tenths

Letter locations are panel edge to lower left corner

LETTER POSITIONS (X)				LENGTH	SERIES/SIZE
M	I	L	E		B4
2.1	4.8	6	8.1	7.5	
5					D10
2.6				6.5	
5					D10
2.9				6.8	
.					D10
1.6				1.5	
5					D10
3.5				6.8	

SIGN DETAIL
1:100

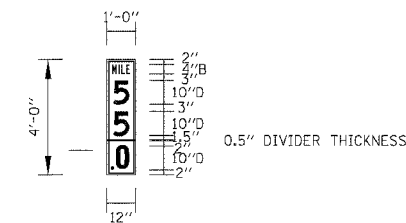

SIGN NUMBER	PS07-01
WIDTH x HIGHT.	1'-0" x 4'-0"
BORDER WIDTH	0.5"
CORNER RADIUS	1.5"
MOUNTING	Barrier
BACKGROUND	TYPE: Reflective COLOR: Green
LEGEND/BORDER	TYPE: Reflective COLOR: White

SYMBOL	X	Y	WID	HT

Panel Style: guide_exp_distance.ssi
Dimensions are in inches.tenths

Letter locations are panel edge to lower left corner

LETTER POSITIONS (X)				LENGTH	SERIES/SIZE
M	I	L	E		B4
2.1	4.8	6	8.1	7.5	
5					D10
2.8				6.8	
5					D10
2.9				6.8	
.					D10
1.6				1.5	
0					D10
3.5				6.8	

REVISIONS	
NAME	DATE

ILLINOIS DEPARTMENT OF TRANSPORTATION
F.A.I. 90/94 (DAN RYAN EXPRESSWAY)
GARFIELD BLVD TO 31ST STREET (NB LOCAL LANES)
SIGN PANEL DETAILS-1

SCALE: NONE
DATE: 06/09/06

DRAWN BY: RV
CHECKED BY: AS

SGN-09

F.A.I. RTE.	SECTION	COUNTY	TOTAL SHEETS	SHEET NO.
94/90	*	COOK	565	292
STA.	TO STA.			
FED. ROAD DIST. NO.	ILLINOIS	FED. AID PROJECT		
* 62301 (2021-922 PT2 ETC 2324.6-1P) R-10				

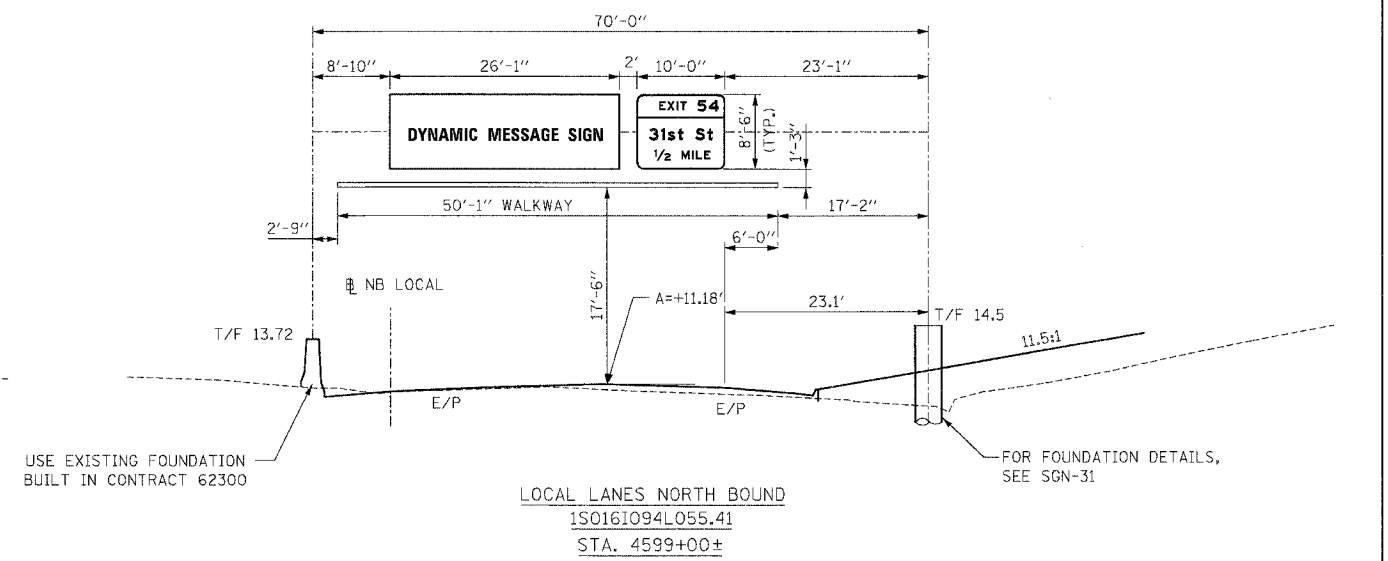
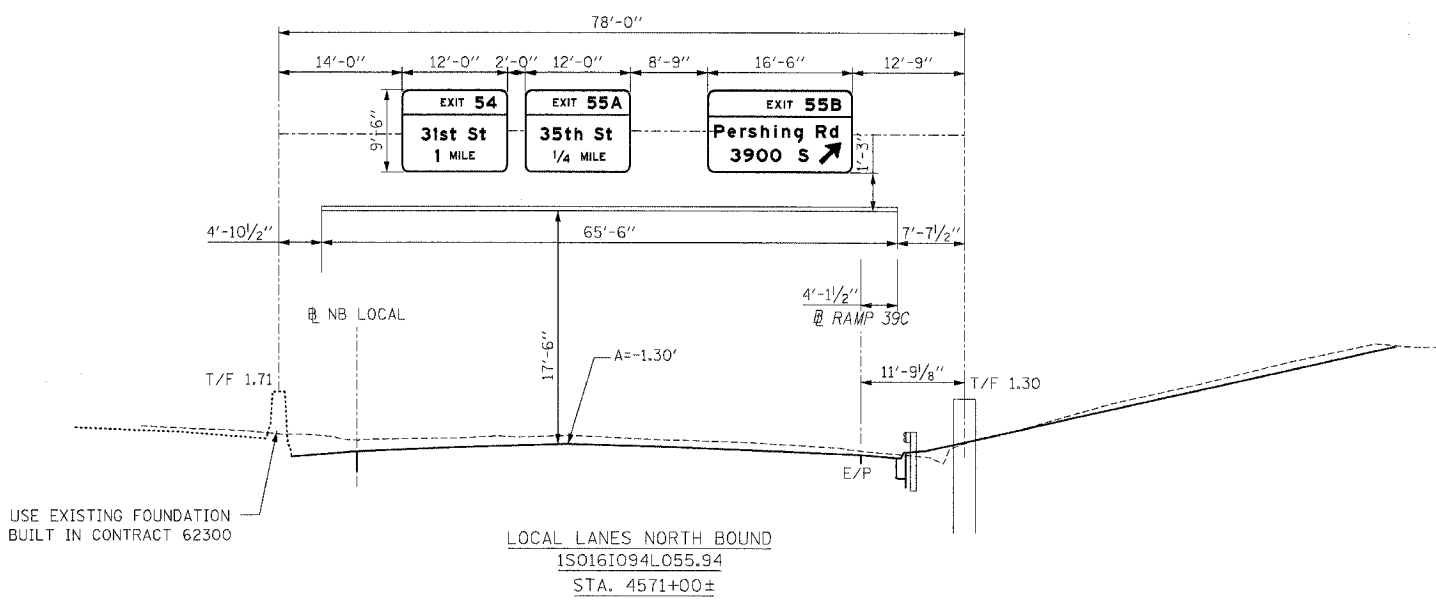
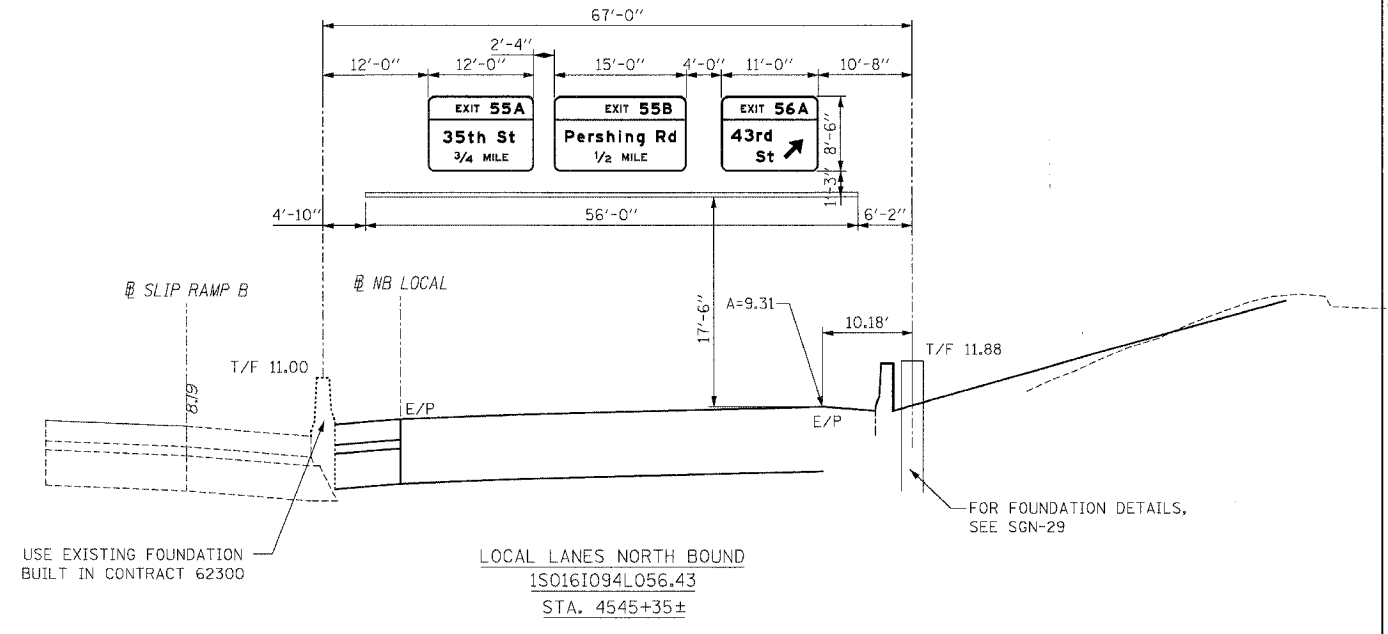
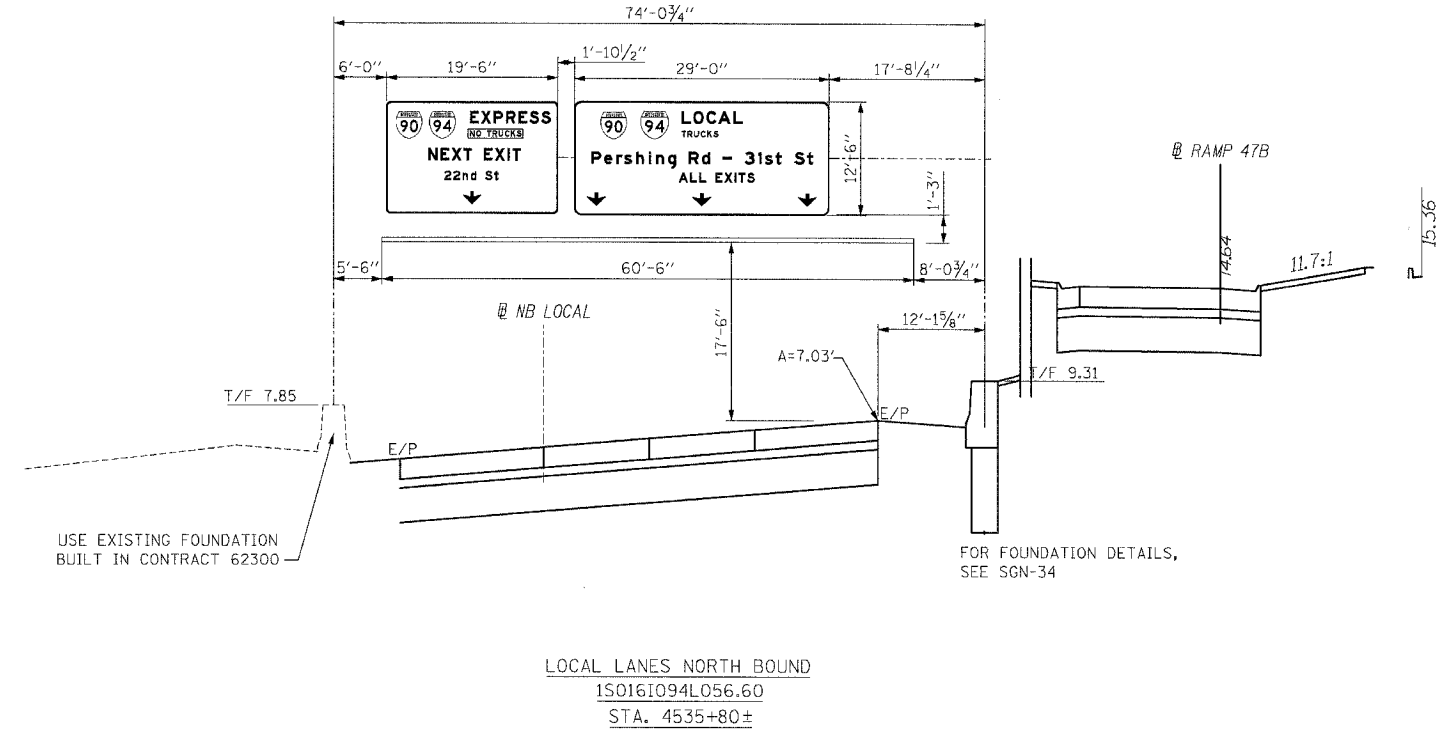

KAM ENGINEERING, INC.
CONSULTING ENGINEERS
707A Davis Road, Suite 205
Elgin, Illinois 60123-1369

REVISIONS	
NAME	DATE

ILLINOIS DEPARTMENT OF TRANSPORTATION
F.A.I. 90/94 (DAN RYAN EXPRESSWAY)
GARFIELD BLVD TO 31ST STREET (NB LOCAL LANES)
SIGN PLACEMENT DETAILS

SCALE: NONE
DATE: 06/09/06

DRAWN BY: RV
CHECKED BY: MSA

SGN-10

6/7/2006 1:50:07 PM

STATE OF ILLINOIS
DEPARTMENT OF TRANSPORTATION

ROUTE NO.	SECTION	COUNTY	SHEET NO.	TOTAL SHEETS
F.A.I. RTE. 90/94		COOK	565	254
FED. ROAD DIST. NO. 1	ILLINOIS	FED. AID PROJECT-		
11818, ETC. 2324.6-1P1 R-10				62301

GENERAL NOTES

DESIGN: AASHTO Standard Specifications for Structural Supports for Highway Signs, Luminaires and Traffic Signals. ("AASHTO Specifications")

CONSTRUCTION: Current (at time of letting) Illinois Department of Transportation Standard Specifications for Road and Bridge Construction, Supplemental Specifications and Special Provisions. ("Standard Specifications")

LOADING: 90 M.P.H. WIND VELOCITY

WIND LOADING: 30 p.s.f. normal to Sign Panel Area and truss elements not behind sign Loading Diagram.

WALKWAY LOADING: Dead load plus 500 lbs. concentrated live load.

DESIGN STRESSES:
Field Units
f_c = 3,500 p.s.i.
f_y = 60,000 p.s.i. (reinforcement)

WELDING: All welds to be continuous unless otherwise shown. All welding to be done in accordance with current AWS D1.1 and D1.2 Structural Welding Codes (Steel and Aluminum) and the Standard Specifications.

MATERIALS: Aluminum Alloys as shown throughout plans. All Structural Steel Pipe shall be ASTM A53 Grade B with a minimum yield of 35,000 p.s.i., or A500 Grade B or C with a minimum yield of 46,000 p.s.i. If A500 pipe is substituted for A53, then the outside diameter shall be as detailed and wall thickness greater than or equal to A53.

All Structural Steel Plates and Shapes shall conform to AASHTO M270 Gr. 36, Gr. 50 or Gr. 50W*. Stainless steel for shims, sleeves and handhole covers shall be ASTM A240, Type 302 or 304, or another alloy suitable for exterior exposure and acceptable to the Engineer.

The steel pipe and stiffening ribs at the base plate for the column shall have a minimum longitudinal Charpy V-Notch (CVN) energy of 15 lb.-ft. at 40° F. (Zone 2) before galvanizing.

FASTENERS FOR ALUMINUM TRUSSES: All bolts noted as "high strength" must satisfy the requirements of AASHTO M164 (ASTM A325), or approved alternate, and must have matching lock nuts. Threaded studs for splices (if Members interfere) must satisfy the requirements of ASTM A449, ASTM A193, Grade B7, or approved alternate, and must have matching lock nuts. Bolts and lock nuts not required to be high strength must satisfy the requirements of ASTM A307. All bolts and lock nuts must be hot dip galvanized per AASHTO M232. The lock nuts must have nylon or steel inserts. A stainless steel flat washer conforming to ASTM A240 Type 302 or 304, is required under both head and nut or under both nuts where threaded studs are used. High strength bolt installation shall conform to Article 505.04 (f) (2) of the IDOT Standard Specifications for Road and Bridge Construction. Rotational capacity ("ROCAP") testing of bolts will not be required.

U-BOLTS AND EYEBOLTS: U-Bolts and Eyebolts must be produced from ASTM A276 Type 304, 304L, 316 or 316L, Condition A, cold finished stainless steel, or an equivalent material acceptable to the Engineer. All nuts for U-Bolts and Eyebolts must be lock nuts equivalent to ASTM A307 with nylon or steel inserts and hot dip galvanized per AASHTO M232. A stainless steel flat washer conforming to ASTM A240, Type 302 or 304, is required under each U-Bolt and Eyebolt lock nut.

GALVANIZING: All Steel Grating, Plates, Shapes and Pipe shall be Hot Dip Galvanized after fabrication in accordance with AASHTO M111. Painting is not permitted.

ANCHOR RODS: Shall conform to AASHTO M314 Gr. 36 or 55 with a minimum Charpy V-Notch (CVN) energy of 15 lb.-ft. at 40° F.

CONCRETE SURFACES: All concrete surfaces above an elevation 6" below the lowest final ground line at each foundation shall be cleaned and coated with Bridge Seat Sealer in accordance with the Standard Specifications.

REINFORCEMENT BARS: Reinforcement Bars designated (E) shall be epoxy coated in accordance with the Standard Specifications.

* If M270 Gr. 50W (M222) steel is proposed, chemistry for plate to be used shall first be approved by the Engineer as suitable for galvanizing and welding.

SGN-12

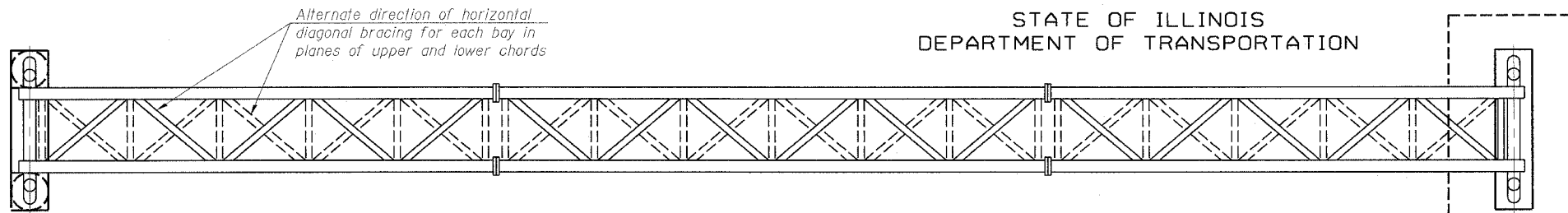

TYPICAL PLAN
(Interior diagonals not shown)

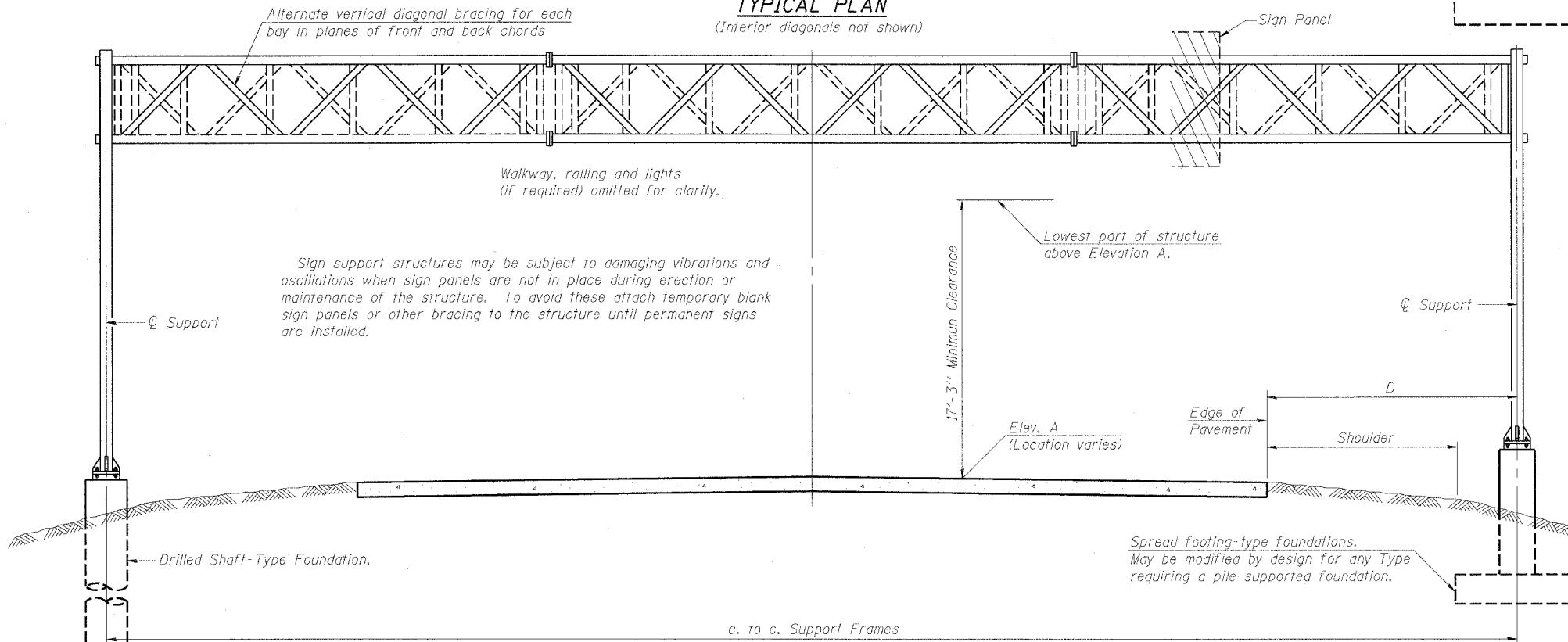

TYPICAL ELEVATION
(Looking at Face of Signs)**

Elev. A = Elevation at point of minimum clearance to sign, walkway support or truss.

Structure Number	Station	Design Truss Type	c. to c. Supports	Elev. A	Dim. D	Height of Tallest Sign	Total Sign Area
ISO161094L057.3	4498+00.00	I-A	65'	2.76'	6.82'L 19.18'R	8.0'	168.0 SF
ISO161094L057.1	4506+75.00	I-A	68'	0.57'	7.36'L 16.18'R	12.5'	310.0 SF
ISO161094L056.9	4518+40.00	II-A	98'	8.84'	10.38'L 21.56'R	8.0'	296.0 SF
ISO161094L056.60	4535+80.00	I-A	74'-0 ³ / ₄ "	7.03'	12.14'	12.5'	606.0 SF
ISO161094L056.43	4545+35.00	I-A	67'	9.31'	10.18'	8.5'	323.0 SF
ISO161094L055.94	4571+00.00	I-A	78'	-1.3'	11.76'	9.5'	385.0 SF
ISO161094L055.41	4599+00.00	III-A	70'	11.18'	23.12'	8.5'	307.0 SF

**Looking upstation for structures with signs both sides.

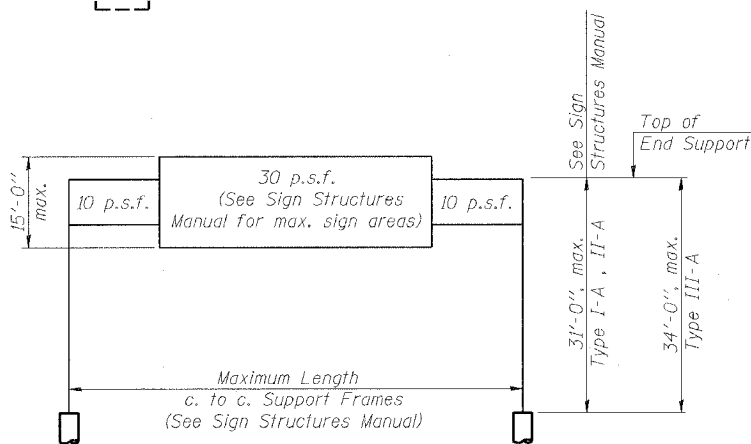

DESIGN WIND LOADING DIAGRAM

Parameters shown are basis for I.D.O.T. Standards and Sign Manual Tables. Installations not within dimensional limits shown require special analysis for all components.

DESIGNED	JSS
CHECKED	RDP
DRAWN	JSS
CHECKED	RDP

EXAMINED	20
PASSED	ENGINEER OF STRUCTURAL SERVICES
	ENGINEER OF BRIDGES AND STRUCTURES

OS-A-1

1-7-05

TOTAL BILL OF MATERIAL

NUMBER	REVISION	DATE

ITEM	UNIT	TOTAL
OVERHEAD SIGN STRUCTURE TYPE I-A (4'-0" x 4'-6")	Foot	352
OVERHEAD SIGN STRUCTURE TYPE II-A (4'-6" x 5'-3")	Foot	98
OVERHEAD SIGN STRUCTURE TYPE III-A (5'-0" x 7'-0")	Foot	70
OVERHEAD SIGN STRUCTURE WALKWAY TYPE A	Foot	360.8
CONCRETE FOUNDATIONS	Cu. Yds.	
DRILLED SHAFT CONCRETE FOUNDATIONS	Cu. Yds.	90.9

OVERHEAD SIGN STRUCTURES
GENERAL PLAN & ELEVATION
ALUMINUM TRUSS & STEEL SUPPORTS

F.A.I. 90/94 (DAN RYAN EXPRESSWAY)
GARFIELD BLVD TO 31ST STREET (NB LOCAL LANES)
PROPOSED IMPROVEMENT
GARFIELD BLVD TO 31ST STREET

6/17/2006 11:26:20 AM

STATE OF ILLINOIS
DEPARTMENT OF TRANSPORTATION

ROUTE NO.	SECTION	COUNTY	TOTAL SHEETS	SHEET NO.
F.A.I. RTE. 90/94		COOK	565	255
FED. ROAD DIST. NO. 1	ILLINOIS	FED. AID PROJECT-		
• (1818, ETC. 2324.6-1P) R-10				62301

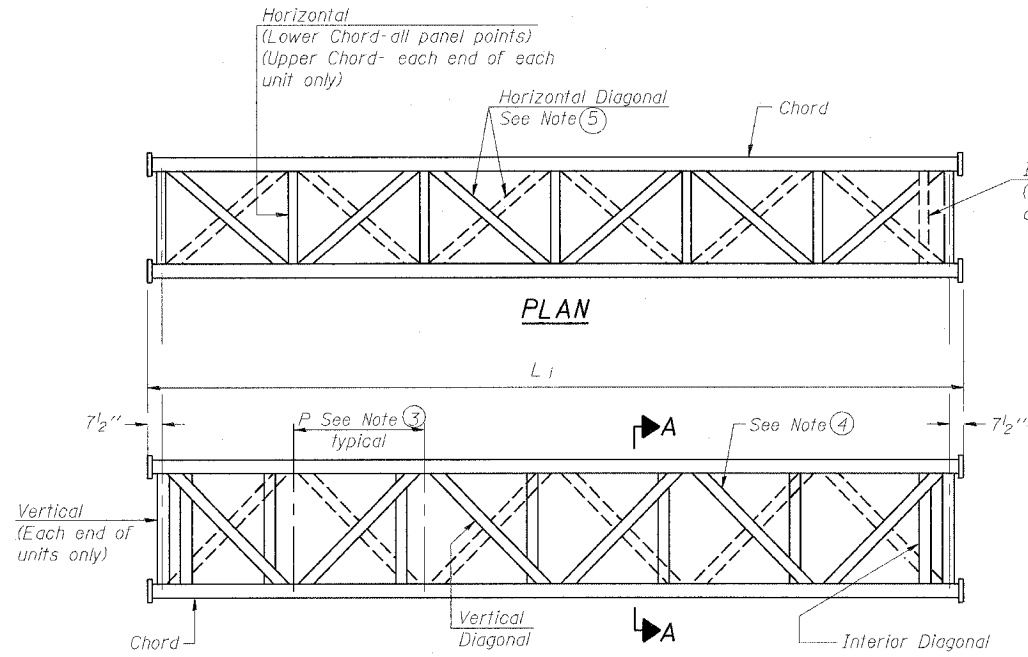

**ELEVATION
TYPICAL INTERIOR UNIT**

Even number of panels/interior unit required.

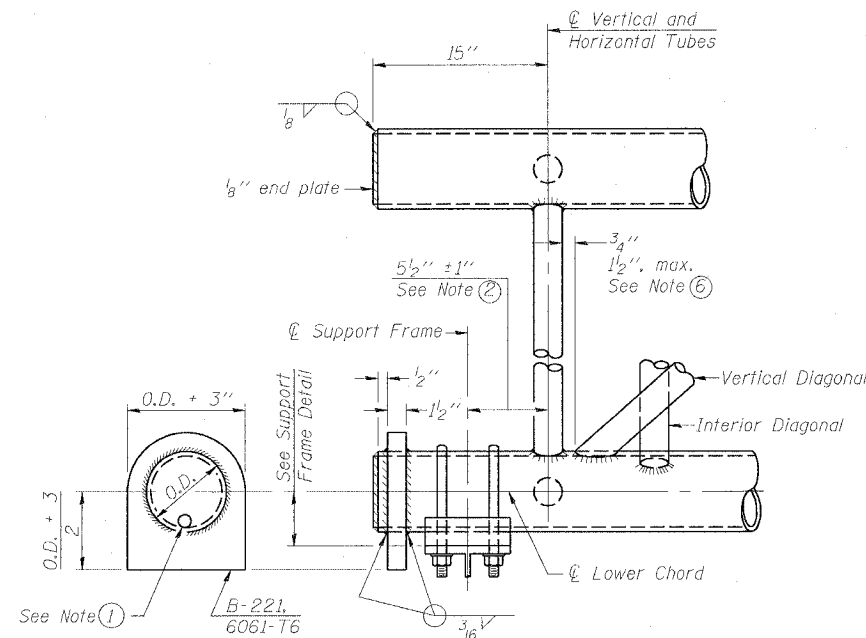

SUPPORT END DETAIL FOR EXTERIOR UNIT

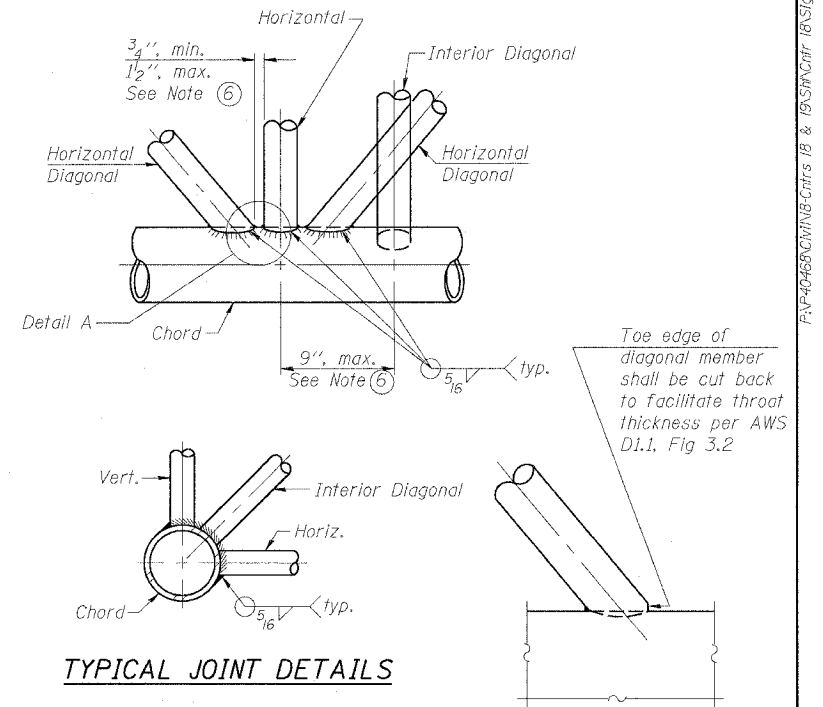

TYPICAL JOINT DETAILS

DETAIL A

NOTES

- Contractor may alternatively use standard aluminum drive-fit cap to close end. 1/2" ϕ drain hole in end plate/drive-fit cap. (Typ. at ends of all chords)
- 5 1/2" end dimension may vary by $\pm 1"$ to provide uniform panel spacing (P).
- Panel spacing (P) shall be uniform for entire truss and between 4'-0" and 5'-0" for Type I-A or 4'-0" and 5'-6" for Types II-A and III-A.
- Vertical Diagonals in front and back face shall alternate.
- Hidden lines show wind bracing alternates direction between planes of top and bottom chords.
- All diagonals shall be detailed for minimum offset from the panel point based on the following: Offset shall be such as to provide a 3/4" minimum to 1 1/2" maximum clearance between any diagonal and any horizontal or vertical member, and to provide clearance for U-bolt connections of signs or walkway brackets.

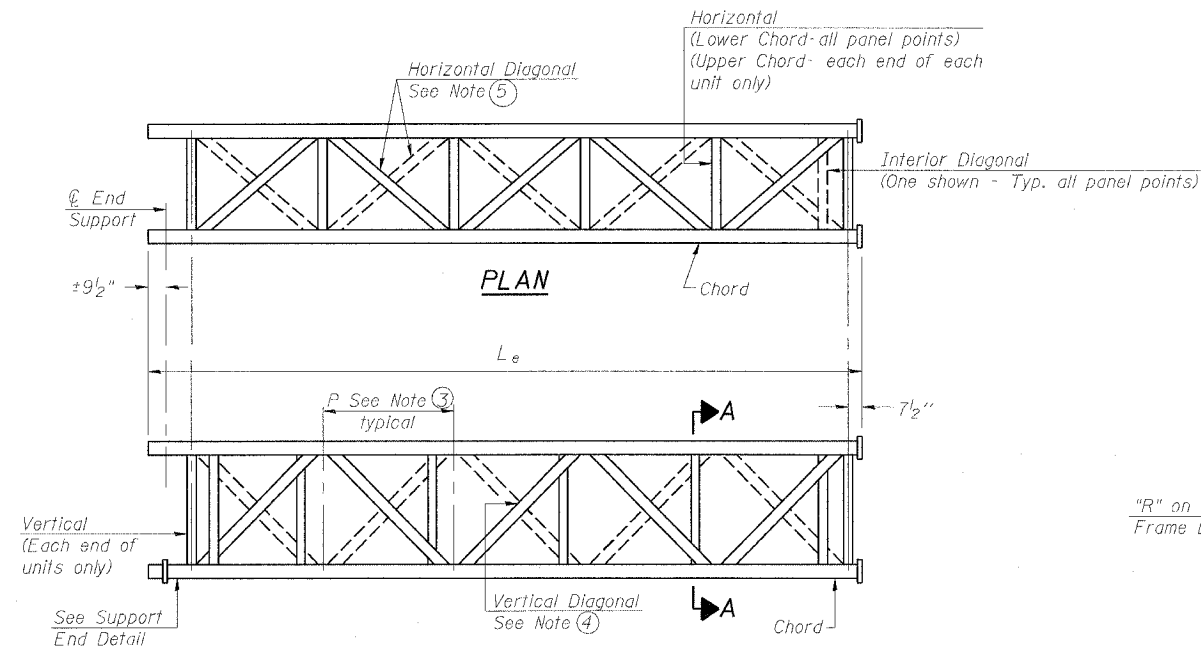

**ELEVATION
TYPICAL EXTERIOR UNIT**

Even or odd number of panels/exterior units allowed.

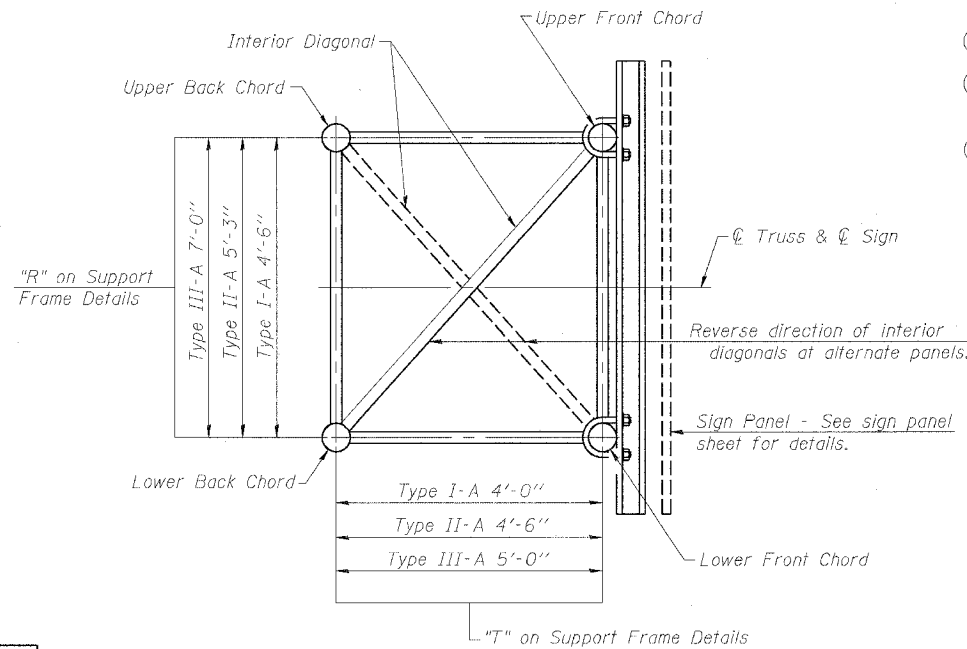

SECTION A-A

DESIGNED	JSS
CHECKED	RDP
DRAWN	JSS
CHECKED	RDP

EXAMINED	20
PASSED	ENGINEER OF STRUCTURAL SERVICES
	ENGINEER OF BRIDGES AND STRUCTURES

NUMBER	REVISION	DATE

OS-A-2

1-7-05

OVERHEAD SIGN STRUCTURES
ALUMINUM TRUSS DETAILS
FOR TRUSS TYPES I-A, II-A and III-A

F.A.I. 90/94 (DAN RYAN EXPRESSWAY)
GARFIELD BLVD TO 31ST STREET (NB LOCAL LANES)
PROPOSED IMPROVEMENT
GARFIELD BLVD TO 31ST STREET

SGN-13

6/7/2006 11:29:02 AM

STATE OF ILLINOIS
DEPARTMENT OF TRANSPORTATION

ROUTE NO.	SECTION	COUNTY	TOTAL SHEETS	SHEET NO.
F.A.I. RTE. 90/94	*	COOK	565	256
FED. ROAD DIST. NO. 1	ILLINOIS	FED. AID PROJECT-		
* U818, ETC, 2324.6-1P) R-10				62301

TRUSS UNIT TABLE

Structure Number	Station	Design Truss Type	Exterior Units (2)			Interior Unit				Upper & Lower Chord		Verticals; Horizontals; Vertical, Horizontal, and Interior Diagonals		Camber at Midspan	Splicing Flange					
			No. Panels per Unit	Unit Lgth.(L _o)	Panel Lgth.(P)	No. Req'd.	No. Panels per Unit	Unit Lgth.(L _i)	Panel Lgth.(P)	O.D.	Wall	O.D.	Wall		Bolts		Weld Sizes		A	B
															No./Splice	Dia.	W	W ₁		
ISO161094L057.3	4498+00.00	I-A	7	33'-4 1/2"	4'-6"	0	--	--	--	5"	1/4"	2 1/2"	1/4"	1.50"	6	7/8"	5/16"	1/4"	8 3/4"	11 3/4"
ISO161094L057.1	4506+75.00	I-A	7	34'-10"	4'-8 1/2"	0	--	--	--	5"	1/4"	2 1/2"	1/4"	1.65"	6	7/8"	5/16"	1/4"	8 3/4"	11 3/4"
ISO161094L056.9	4518+40.00	II-A	6	33'-4 1/2"	5'-3"	1	6	32'-9"	5'-3"	6"	5/16"	3"	5/16"	2.40"	6	7/8"	3/8"	1/4"	10 1/4"	13 3/4"
ISO161094L056.60	4535+80.00	I-A	8	37'-10 3/8"	4'-0"	--	--	--	--	5"	5/16"	2 1/2"	5/16"	1.95"	6	7/8"	5/16"	1/4"	8 3/4"	11 3/4"
ISO161094L056.43	4545+35.00	I-A	7	34'-3"	4'-7 1/2"	--	--	--	--	5"	1/4"	2 1/2"	1/4"	1.60"	6	7/8"	5/16"	1/4"	8 3/4"	11 3/4"
ISO161094L055.94	4571+00.00	I-A	8	39'-10 1/2"	4'-9"	--	--	--	--	5"	5/16"	2 1/2"	5/16"	2.15"	6	7/8"	5/16"	1/4"	8 3/4"	11 3/4"
ISO161094L055.41	4599+00.00	III-A	7	35'-8 1/2"	4'-10"	--	--	--	--	7"	5/16"	3 1/4"	5/16"	1.75"	6	1"	7/16"	5/16"	11 1/2"	15"

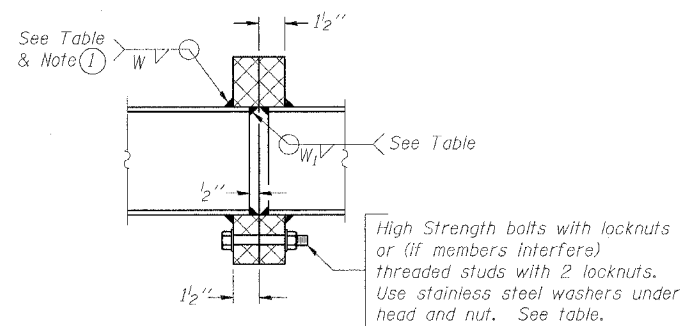

SECTION B-B

1 Splicing Flanges shall be attached to each truss unit with the truss shop assembled to camber shown. Truss units shall be in proper alignment and flange surfaces shall be shop bolted into full contact before welding. Sufficient external welds or tacks shall be made to secure flanges until remaining welds are made after disassembly. Adjacent flanges shall be "match marked" to insure proper field assembly.

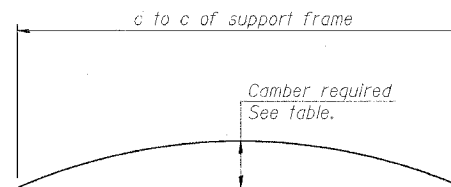
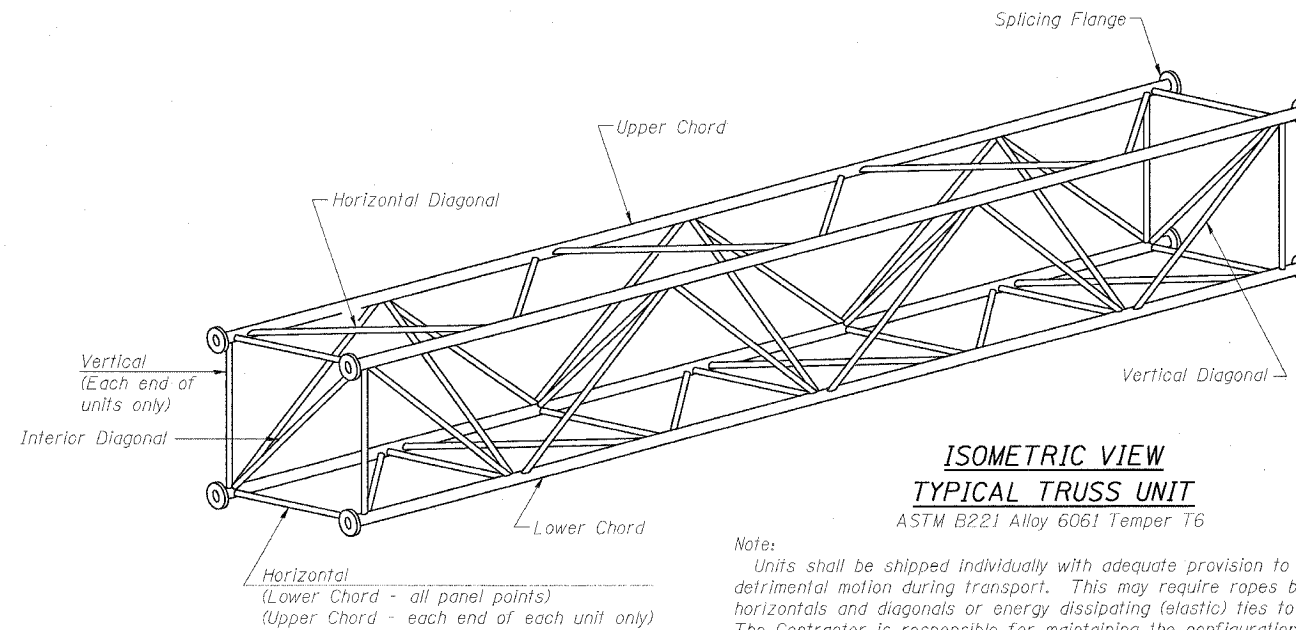

CAMBER ATTAINMENT EXAMPLES:

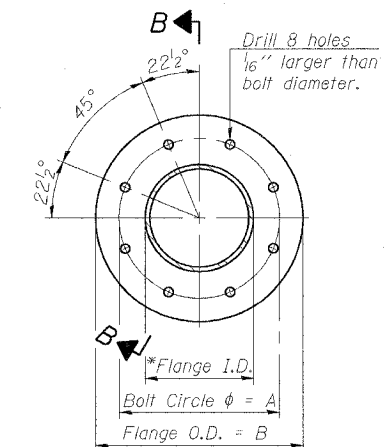
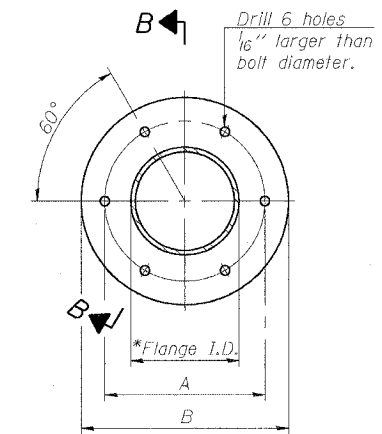
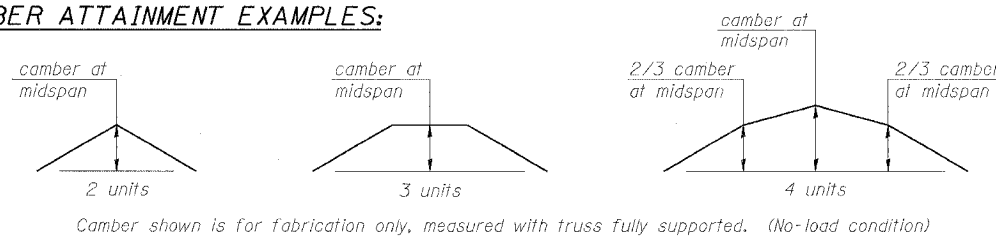

SPLICING FLANGES

ASTM B221, Alloy 6061-T6
or ASTM B209, Alloy 6061-T651

*To fit O.D. of Chord with maximum gap of 1/16".

NUMBER	REVISION	DATE

DESIGNED - JSS	20
CHECKED - RDP	EXAMINED
DRAWN - JSS	PASSED
CHECKED - RDP	ENGINEER OF BRIDGES AND STRUCTURES

OS4-A-2

1-7-05

OVERHEAD SIGN STRUCTURES
ALUMINUM TRUSS DETAILS
FOR TRUSS TYPES I-A, II-A and III-A

F.A.I. 90/94 (DAN RYAN EXPRESSWAY)
GARFIELD BLVD TO 31ST STREET (NB LOCAL LANES)
PROPOSED IMPROVEMENT
GARFIELD BLVD TO 31ST STREET

SGN-14

6/7/2006 11:28:50 AM

STATE OF ILLINOIS
DEPARTMENT OF TRANSPORTATION

* Center of horizontal to center of splice dimension may vary. Verify before drilling holes in mounting tube.

ROUTE NO.	SECTION	COUNTY	TOTAL SHEETS	SHEET NO.
F.A.I. RTE. 90/94	*	COOK	565	257
FED. ROAD DIST. NO. 1	ILLINOIS	FED. AID PROJECT		
* (1818, ETC. 2324.6-1P) R-10				

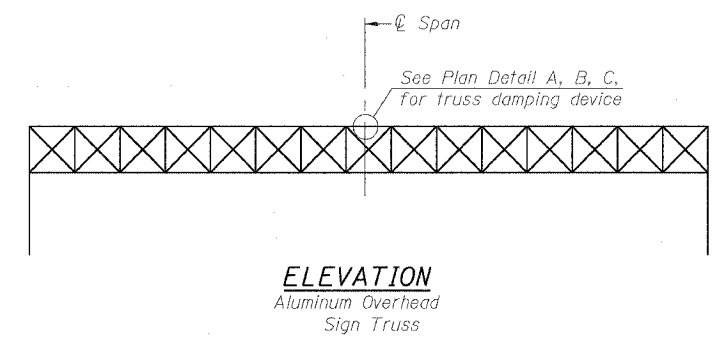
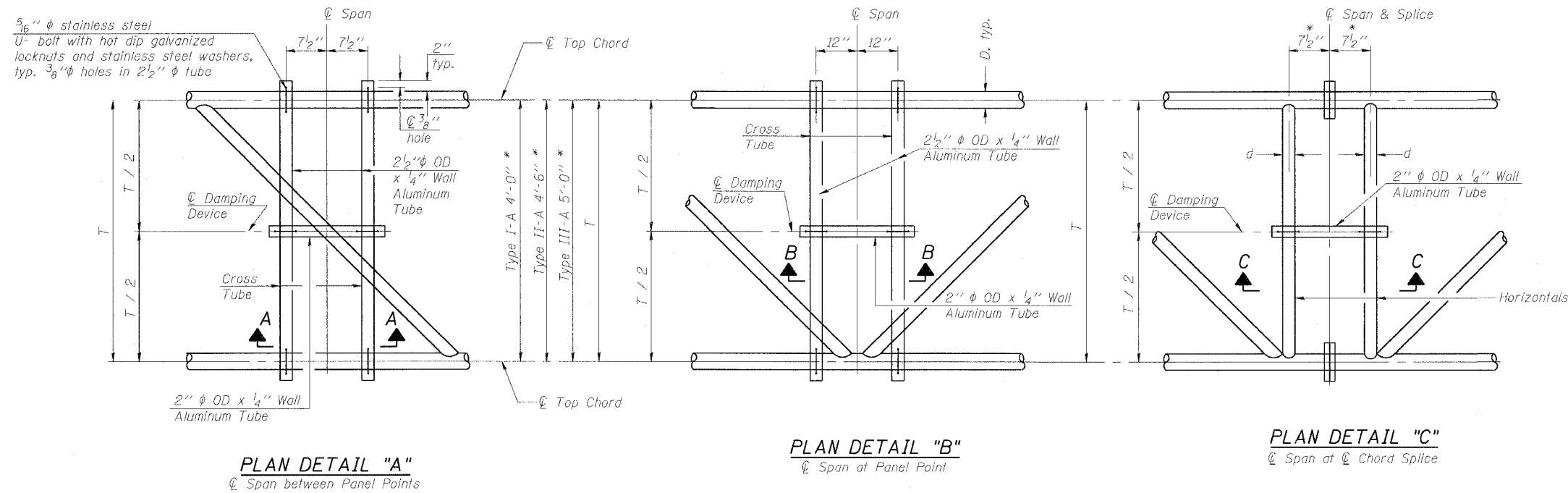

NOTES
Damper: One damper per truss.
(31 lbs. Stockbridge-Type Aluminum)
Cost included in Overhead Sign Structure...
Materials: Aluminum tubes shall be ASTM B221 alloy 6061 temper T6. Cost included in Overhead Sign Structure...

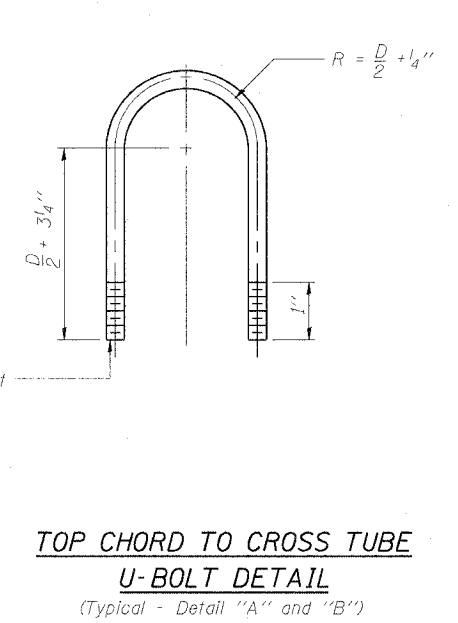
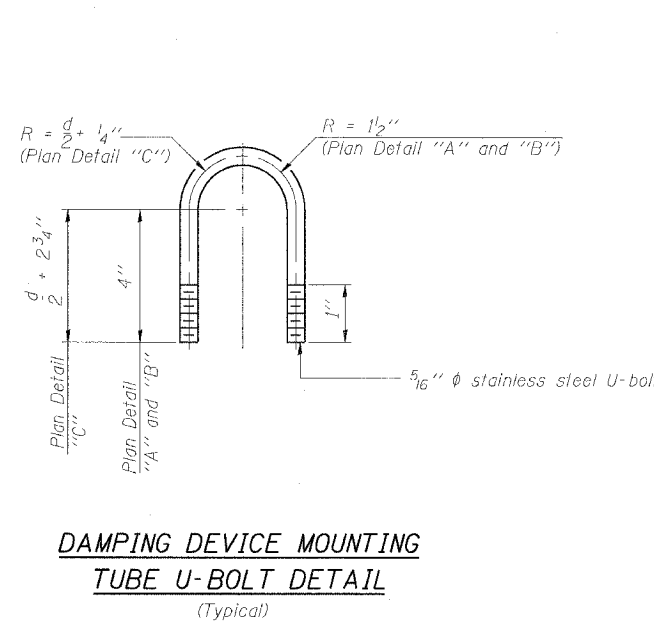
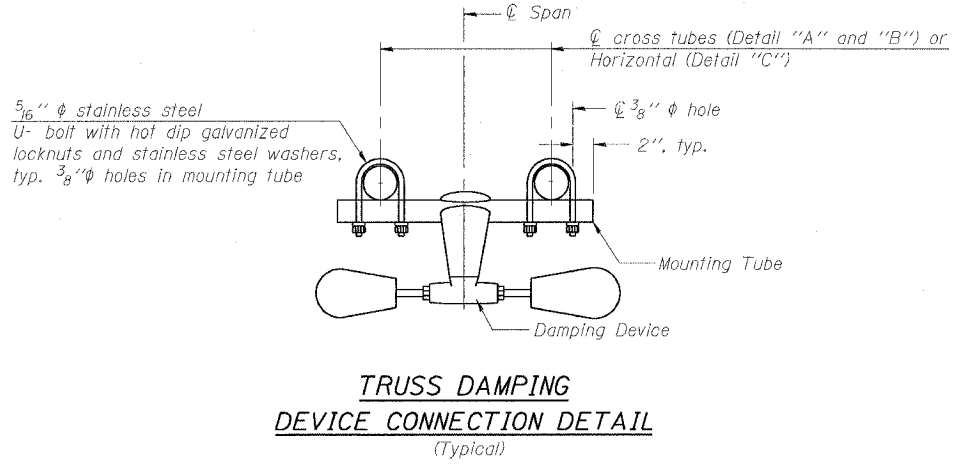
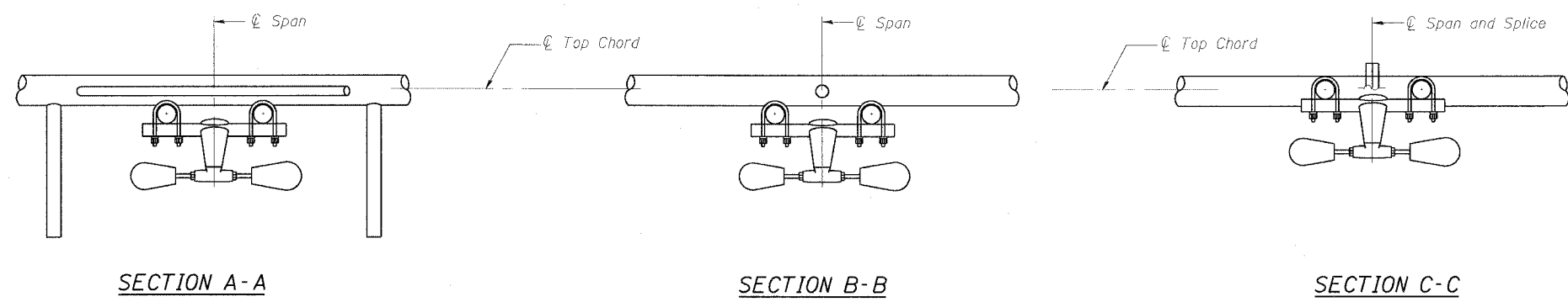

DESIGNED - JSS	20
CHECKED - RDP	EXAMINED
DRAWN - JSS	PASSED
CHECKED - RDP	ENGINEER OF STRUCTURAL SERVICES
	ENGINEER OF BRIDGES AND STRUCTURES

OS-A-D 1-7-05

SGN-15

**OVERHEAD SIGN STRUCTURE
DAMPING DEVICE**

F.A.I. 90/94 (DAN RYAN EXPRESSWAY)
GARFIELD BLVD TO 31ST STREET (NB LOCAL LANES)
PROPOSED IMPROVEMENT
GARFIELD BLVD TO 31ST STREET

F:\P40468\CH\NB-Cntrs 18 & 19\SGN\Chtr 18\Signing\SGN15A.dgn 11:29:40 AM 6/7/2006

STATE OF ILLINOIS
DEPARTMENT OF TRANSPORTATION

ROUTE NO.	SECTION	COUNTY	TOTAL SHEETS	SHEET NO.
F.A.I. RTE. 90/94	*	COOK	565	258
FED. ROAD DIST. NO. 1	ILLINOIS	FED. AID PROJECT		
11818, ETC, 2324.6-1P1 R-10				62301

3/4" φ stainless steel U-bolt.
Provide two washers and two hexagon locknuts. (4)
1 3/16" x 2" slots on 8" φ pipe.
(4 slots required per pipe)

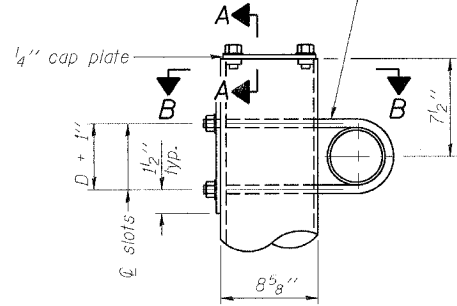

DETAIL A

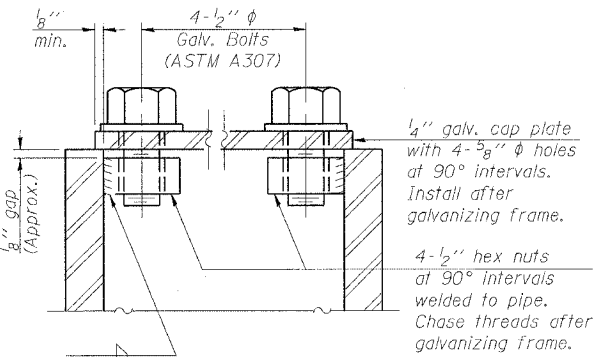

SECTION A-A

As an alternate to bolts, may use galvanized drive-fit caps installed after galvanizing frame.

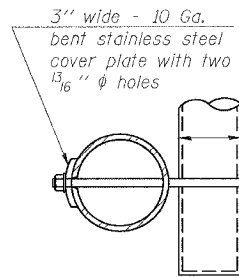

SECTION B-B

"D" = Outside Chord Diameter

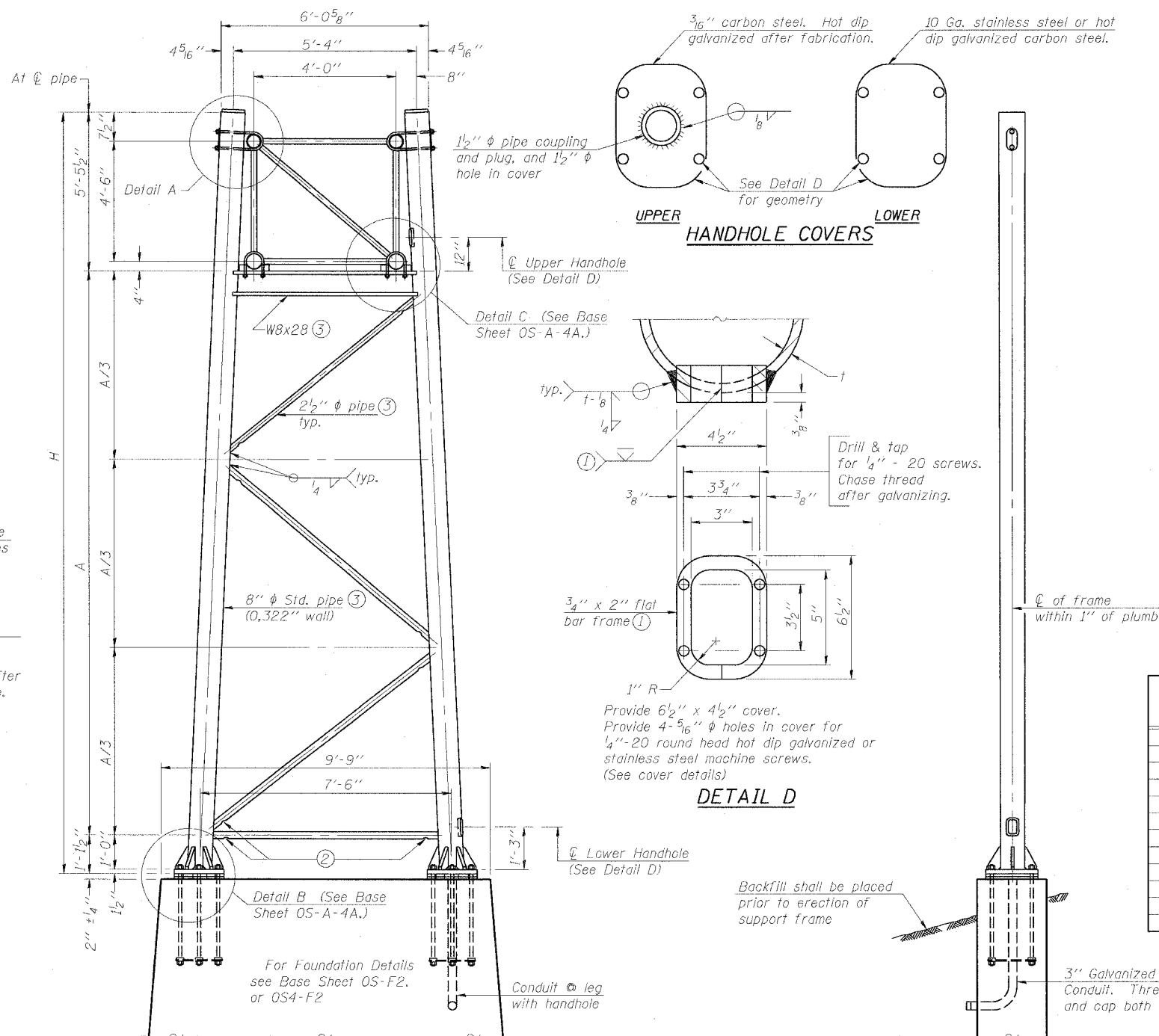

SIDE ELEVATION

END ELEVATION

8" φ PIPE TRUSS SUPPORT FRAME

Support Design Loads: See Base Sheet OS-A-1 for design and loading criteria.
Load combinations checked include deadload plus:
a) 100% wind normal to sign, 20% parallel to sign
b) 60% wind normal to sign, 30% parallel to sign

- In lieu of fabricated handhole frame as shown, may cut from 2" plate (rolling direction vertical). All cut faces to be ground to ANSI Roughness of 500 μm or less.
- Galvanizing vent holes of adequate size shall be provided on underside at each end of bracing pipes. Alternately, holes may be provided in wall of pipe column. All vent holes shall be drilled and de-burred, typ.
- Steel pipe, plate, carbon steel handhole covers and rolled sections shall be hot dip galvanized after fabrication. Painting is not permitted. See Base Sheet OS-A-1.
- See General Notes for fasteners.
- Dimensions shown are based on selection criteria in the Sign Structures Manual. Nonstandard applications must have dimensions verified or amended as appropriate.

Structure Number	Station	Support		H	A
		Left	Right		
ISO161094L057.3	4498+00.00	X		22.72'	16.13'
ISO161094L057.3	4498+00.00		X	19.07'	12.48'
ISO161094L057.1	4506+75.00	X		24.91'	18.32'
ISO161094L057.1	4506+75.00		X	22.37'	15.78'
ISO161094L056.43	4545+35.00	X		24'-0 1/4"	17'-5 1/4"
ISO161094L056.43	4545+35.00		X	23'-1 3/4"	16'-6 3/4"
ISO161094L055.94	4571+00.00	X		23'-2 3/8"	16'-7 3/8"
ISO161094L055.94	4571+00.00		X	23'-7 5/16"	17'-0 5/16"

DESIGNED - JSS	20
CHECKED - RDP	EXAMINED
DRAWN - JSS	PASSED
CHECKED - RDP	ENGINEER OF BRIDGES AND STRUCTURES

NUMBER	REVISION	DATE

SGN-16

OVERHEAD SIGN STRUCTURES
SUPPORT FRAME for TYPE I-A ALUMINUM TRUSS

F.A.I. 90/94 (DAN RYAN EXPRESSWAY)
GARFIELD BLVD TO 31ST STREET (NB LOCAL LANES)
PROPOSED IMPROVEMENT
GARFIELD BLVD TO 31ST STREET

STATE OF ILLINOIS
DEPARTMENT OF TRANSPORTATION

ROUTE NO.	SECTION	COUNT	TOTAL SHEETS	SHEET NO.
F.A.I. RTE. 90/94		COOK	565	259
FED. ROAD DIST. NO. 1	ILLINOIS	FED. AID PROJECT		
• (1818, ETC, 2324, 6-1P) R-10				62301

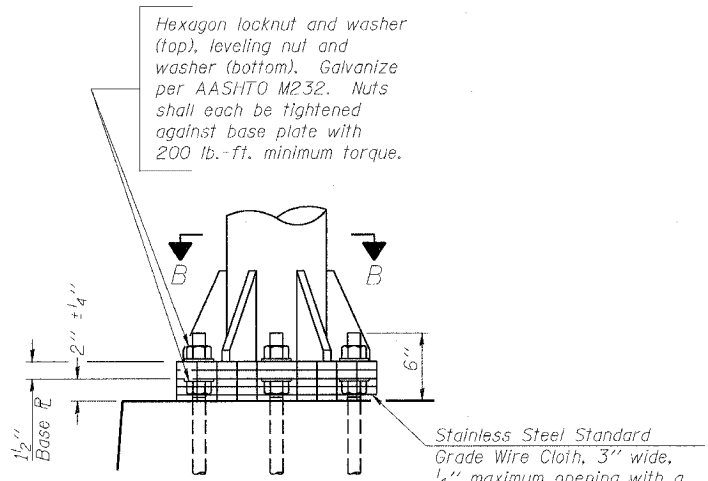

DETAIL B

Ribs shall be cut to fit slope of pipe.
Stainless Steel Standard Grade Wire Cloth, 3" wide, 1/4" maximum wire opening with a minimum wire diameter of AWG. No. 16 with a minimum 2" lap. Secure to base plate after erection with 3/4" stainless steel banding.

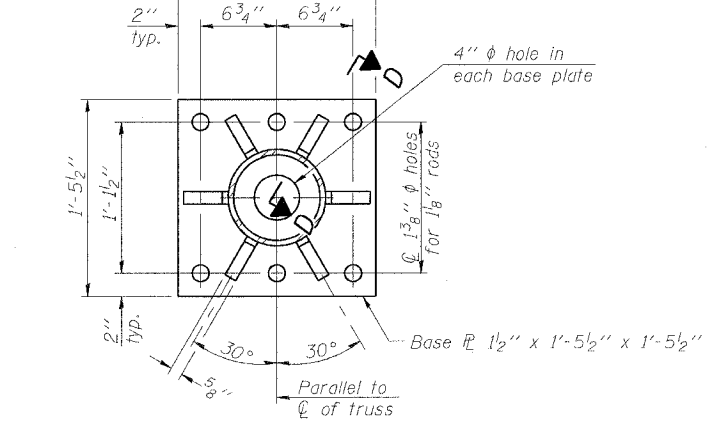

SECTION B-B

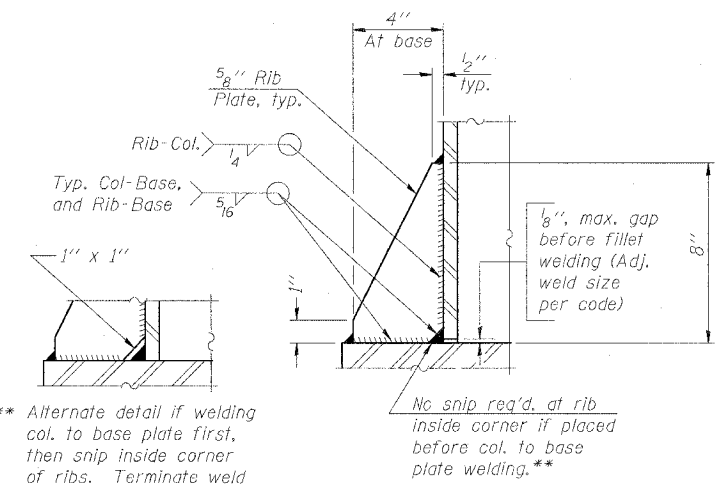

SECTION D-D

** Alternate detail if welding col. to base plate first, then snip inside corner of ribs. Terminate weld on rib 1/4" from snip.

No snip req'd. at rib inside corner if placed before col. to base plate welding.

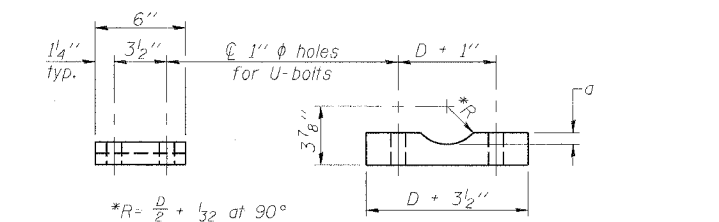

SADDLE SHIM DETAIL

ASTM B26 Alloy 356-F
or
ASTM B209 Alloy 6061-T651
(4 required per sign truss)

Truss Chord Nominal Dia.	a
5"	3/4"
5 1/2"	13/16"
6"	7/8"
6 1/2"	15/16"

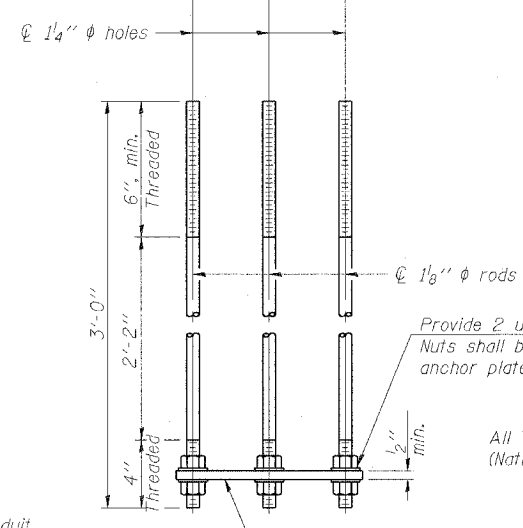
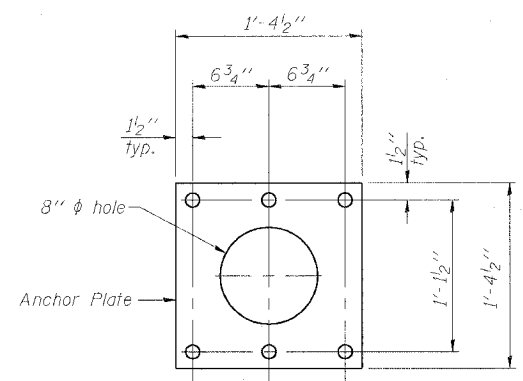

ANCHOR ROD DETAIL
Spread Footing Foundation

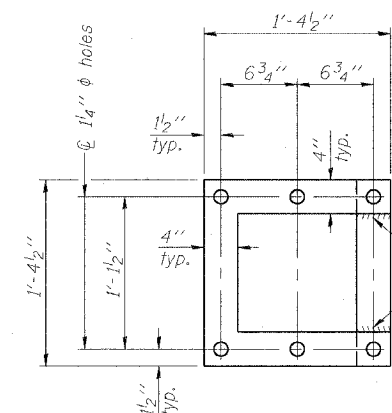

POSITIONING PLATE(S)

Optionally may use four (4) separate bars. Weld to maintain perpendicularity.

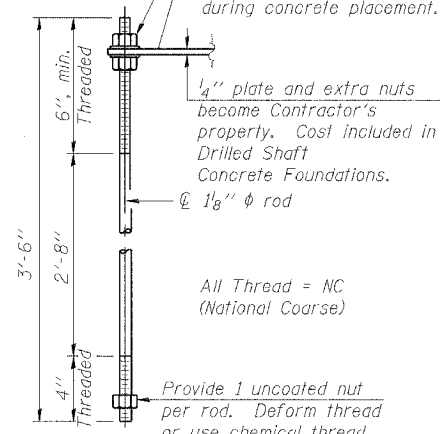

ANCHOR ROD DETAIL
Drilled Shaft Foundation

Anchor rods shall conform to AASHTO M314 Grade 36 or 55 and meet Charpy V-Notch (CVN) energy of 15 lb.-ft. at 40° F. Galvanize upper 12" per AASHTO M232. No welding shall be permitted on rods.

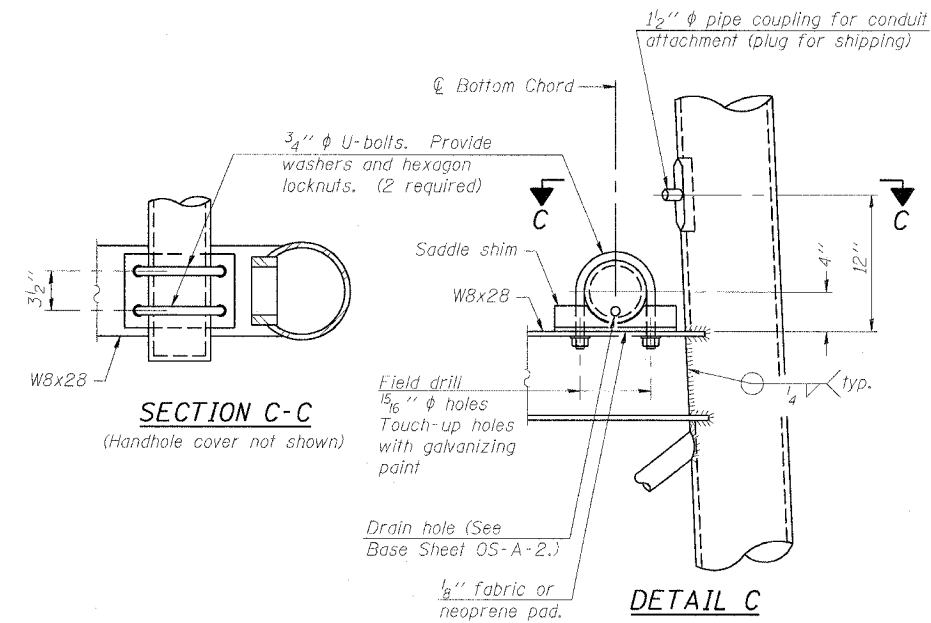

DETAIL C

TYPE I-A TRUSS
8" φ PIPE SUPPORT FRAME DETAILS

NUMBER	REVISION	DATE

DESIGNED - JSS	20
CHECKED - RDP	EXAMINED
DRAWN - JSS	PASSED
CHECKED - RDP	ENGINEER OF BRIDGES AND STRUCTURES

OS-A-4A 1-7-05

SGN-17
OVERHEAD SIGN STRUCTURES
SUPPORT FRAME DETAILS ALUMINUM TRUSS

F.A.I. 90/94 (DAN RYAN EXPRESSWAY)
GARFIELD BLVD TO 31ST STREET (NB LOCAL LANES)
PROPOSED IMPROVEMENT
GARFIELD BLVD TO 31ST STREET

6/7/2006 11:29:34 AM F:\P4046\CH\NB-Ctrrs 18 & 19\SIGN\CH\18\Sign\SSB01724.dgn

STATE OF ILLINOIS
DEPARTMENT OF TRANSPORTATION

ROUTE NO.	SECTION	COUNTY	TOTAL SHEETS	SHEET NO.
F.A.I. RTE. 90/94		COOK	565	260
FED. ROAD DIST. NO. 1	ILLINOIS	FED. AID PROJECT-		
• (1818, ETC. 2324, 6-1P) R-10			62301	

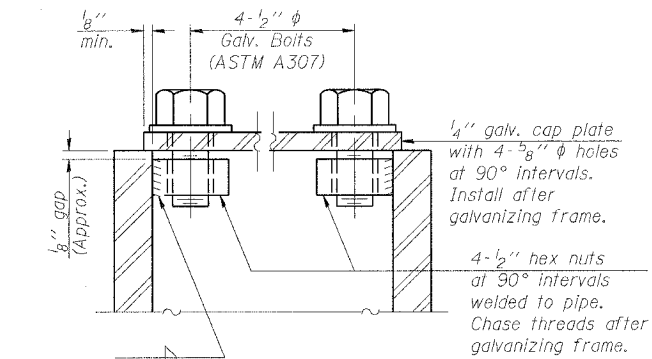
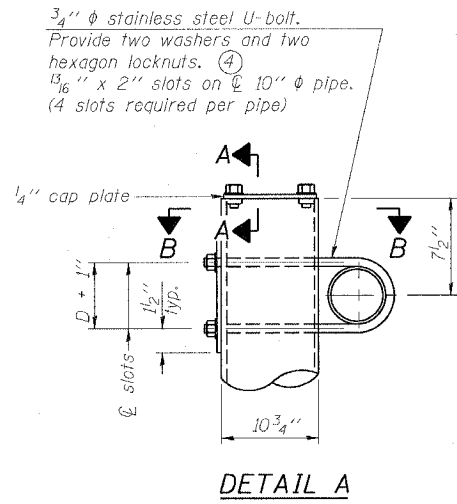

As an alternate to bolts, may use galvanized drive-fit caps installed after galvanizing frame.

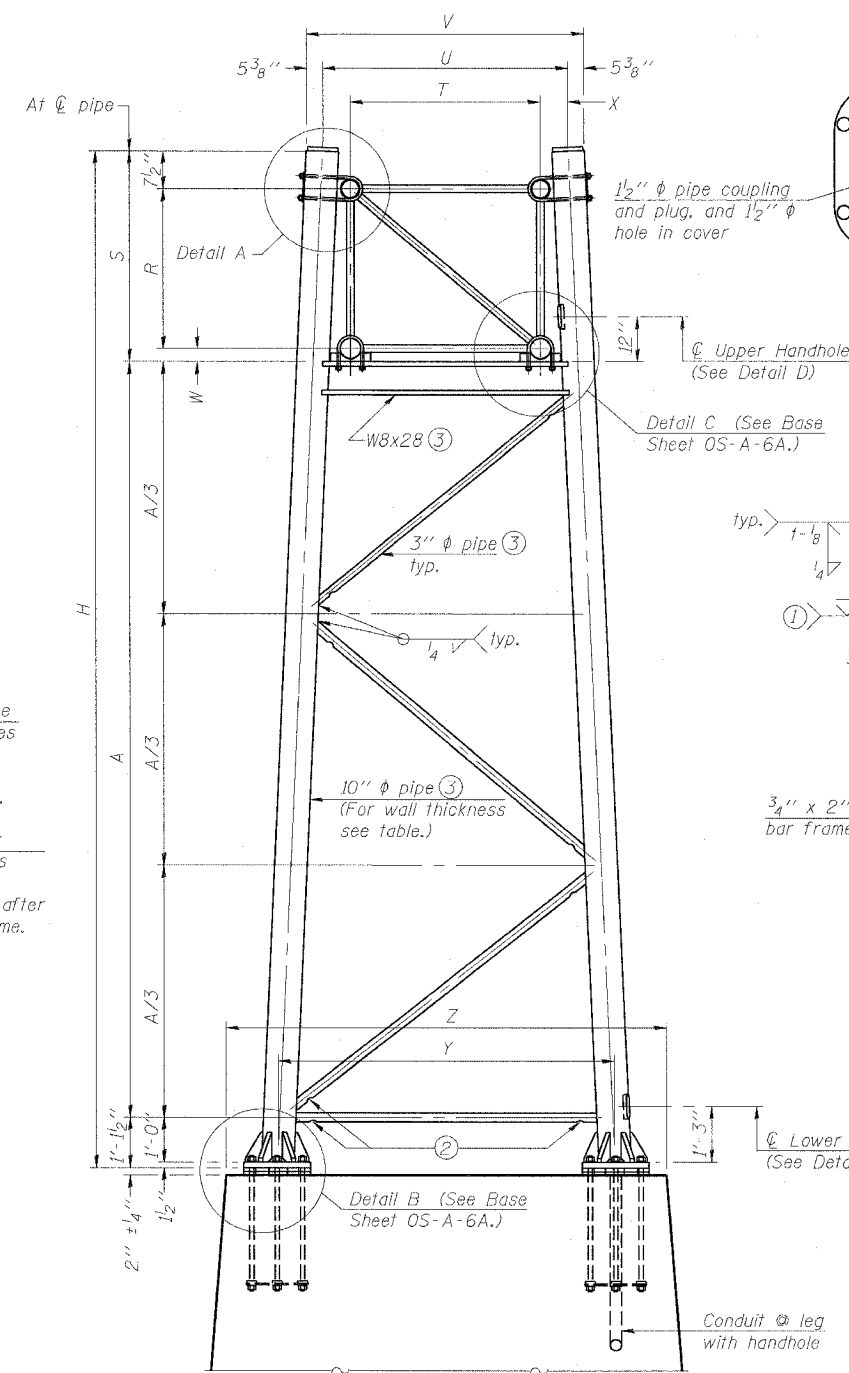
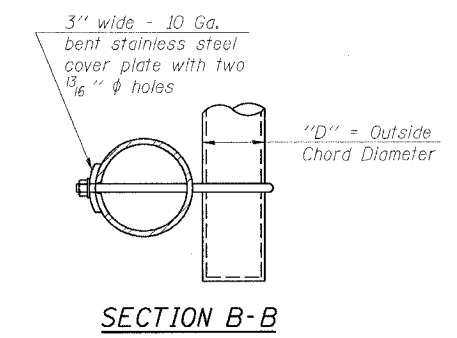

For Foundation Details, see base sheet OS-F3 (Spread Footing) or OS4-F3 (Drilled Shaft).

SIDE ELEVATION

10" ϕ PIPE TRUSS SUPPORT FRAME

Truss Type	Dimensions									
	R	S	T	U	V	W	X	Y	Z	
I-A	4'-6"	5'-5 1/2"	4'-0"	5'-6"	6'-4 3/4"	4"	9"	8'-3"	11'-3"	
II-A (5)	5'-3"	6'-3 1/4"	4'-6"	6'-1"	6'-11 3/4"	4 3/4"	9 1/2"	8'-3"	11'-3"	

Support Design Loads: See Base Sheet OS-A-1 for design and loading criteria.
Load combinations checked include deadload plus:
a) 100% wind normal to sign, 20% parallel to sign
b) 60% wind normal to sign, 30% parallel to sign

- In lieu of fabricated handhole frame as shown, may cut from 2" plate (rolling direction vertical). All cut faces to be ground to ANSI Roughness of 500 μ in or less.
- Galvanizing vent holes of adequate size shall be provided on underside at each end of bracing pipes. Alternately, holes may be provided in wall of pipe column. All vent holes shall be drilled and de-burred, typ.
- Steel pipe, plate, carbon steel handhole covers and rolled sections shall be hot dip galvanized after fabrication. Painting is not permitted. See Base Sheet OS-A-1.
- See General Notes for fasteners.
- Dimensions shown are based on selection criteria in the Sign Structures Manual. Nonstandard applications must have dimensions verified or amended as appropriate.

Structure Number	Station	Support		Truss Type	Pipe Wall Thickness	H	A
		Left	Right				
ISO161094L056.9	4518+40.00	X		II-A	0.365 (Std)	23.15'	15.76'
ISO161094L056.9	4518+40.00		X	II-A	0.365 (Std)	22.12'	14.73'
ISO161094L056.60	4535+80.00	X		I-A	0.279	26'-10 1/16"	20'-3 1/16"
ISO161094L056.60	4535+80.00		X	I-A	0.279	25'-5 3/16"	18'-10 3/16"

DESIGNED - JSS	20
CHECKED - RDP	EXAMINED
DRAWN - JSS	PASSED
CHECKED - RDP	ENGINEER OF STRUCTURAL SERVICES
	ENGINEER OF BRIDGES AND STRUCTURES

OS-A-6 1-7-05

NUMBER	REVISION	DATE

OVERHEAD SIGN STRUCTURES
SUPPORT FRAME for ALUMINUM TRUSS

F.A.I. 90/94 (DAN RYAN EXPRESSWAY)
GARFIELD BLVD TO 31ST STREET (NB LOCAL LANES)
PROPOSED IMPROVEMENT
GARFIELD BLVD TO 31ST STREET

FVP-468-CH/UB-Ctr's 18 & 19/S/MS/Contr 18/5/19/AM/11/23/45 AM 6/7/2006

STATE OF ILLINOIS
DEPARTMENT OF TRANSPORTATION

ROUTE NO.	SECTION	COUNTY	TOTAL SHEETS	SHEET NO.
F.A.I. RTE. 90/94		COOK	565	261
FED. ROAD DIST. NO. 1	ILLINOIS	FED. AID PROJECT		
(1818, ETC. 2324-6-1P) R-10			62301	

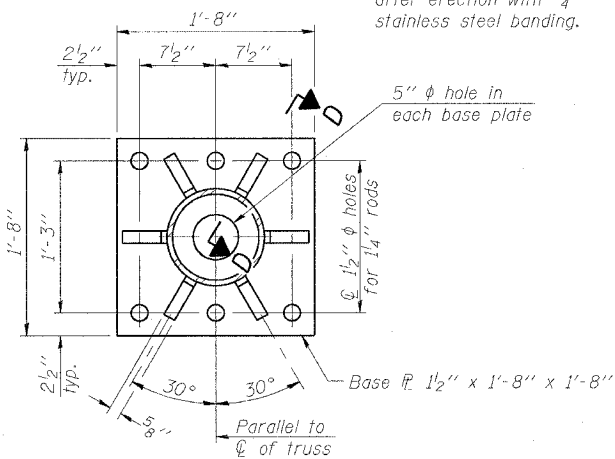
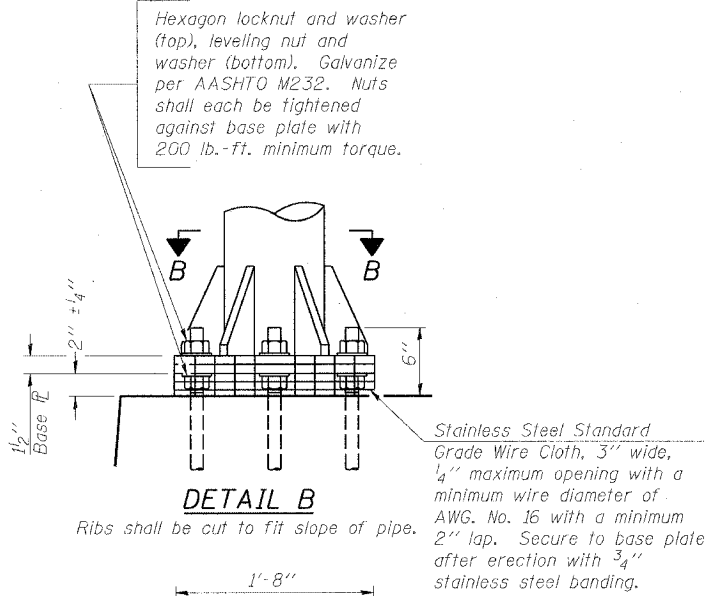

SECTION B-B

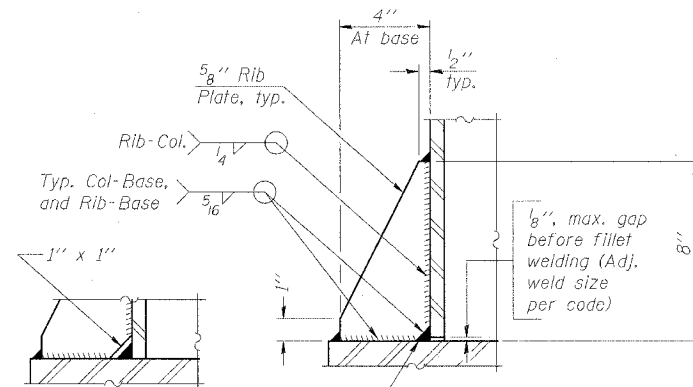

SECTION D-D

** Alternate detail if welding col. to base plate first, then snip inside corner of ribs. Terminate weld on rib 1/4" from snip.

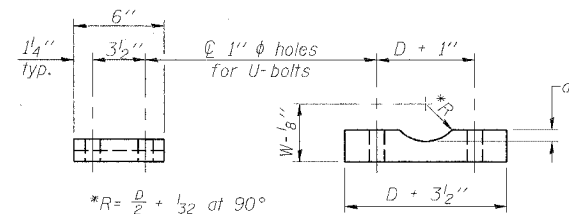

SADDLE SHIM DETAIL

ASTM B26 Alloy 356-F
or
ASTM B209 Alloy 6061-T651
(4 required per sign truss)

Truss Chord Nominal Dia.	a
5"	3/4"
5 1/2"	13/16"
6"	7/8"
6 1/2"	15/16"
7"	1"

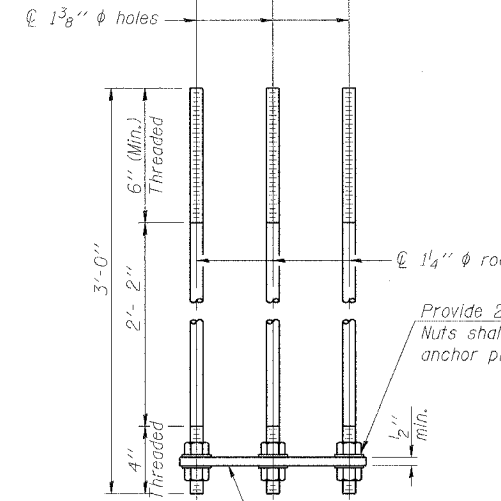
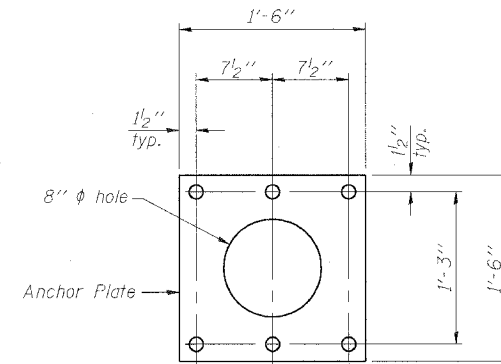

ANCHOR ROD DETAIL
Spread Footing Foundation

Anchor rods shall conform to AASHTO M314 Grade 36 or 50 and meet Charpy V-Notch (CVN) energy of 15 lb.-ft. at 40° F. Galvanize upper 12" per AASHTO M232. No welding shall be permitted on rods.

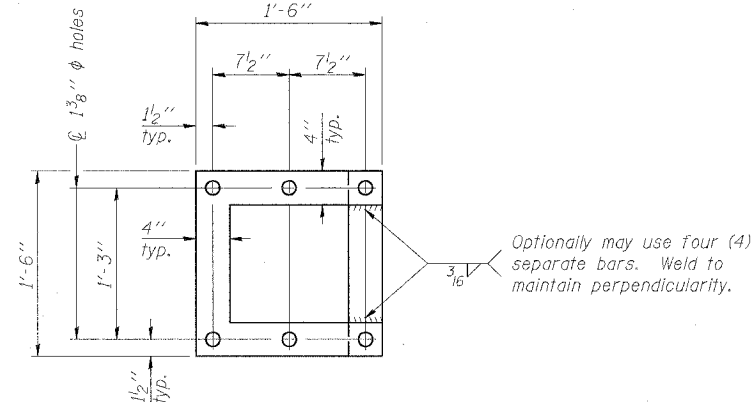

POSITIONING PLATE(S)

ANCHOR ROD DETAIL
Drilled Shaft Foundation

NUMBER	REVISION	DATE

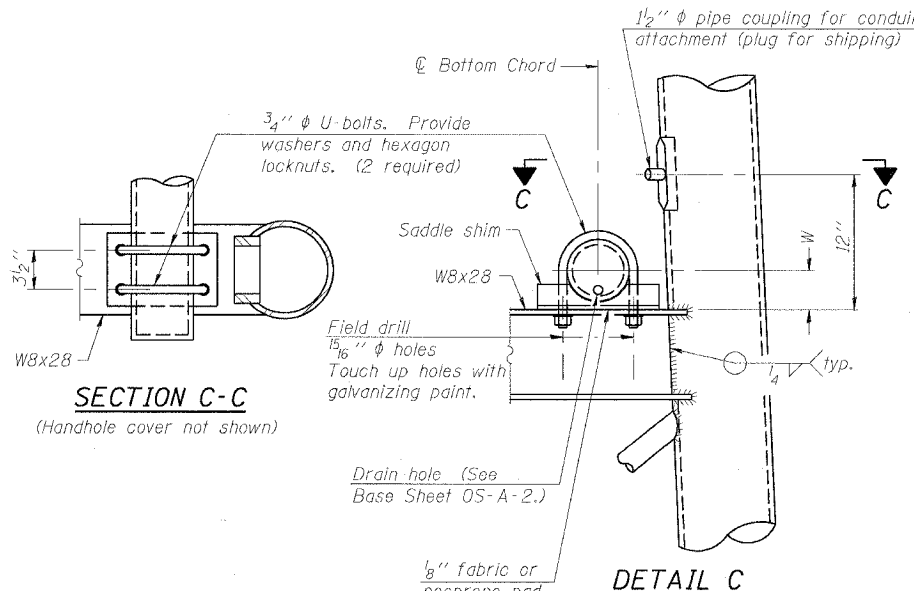

SECTION C-C
(Handhole cover not shown)

DETAIL C

10" ϕ PIPE SUPPORT FRAME DETAILS

OVERHEAD SIGN STRUCTURES
SUPPORT FRAME DETAILS ALUMINUM TRUSS

F.A.I. 90/94 (DAN RYAN EXPRESSWAY)
GARFIELD BLVD TO 31ST STREET (NB LOCAL LANES)
PROPOSED IMPROVEMENT
GARFIELD BLVD TO 31ST STREET

DESIGNED - JSS
CHECKED - RDP
DRAWN - JSS
CHECKED - RDP

EXAMINED
PASSED

ENGINEER OF STRUCTURAL SERVICES
ENGINEER OF BRIDGES AND STRUCTURES

OS-A-6A 1-7-05

SGN-19

PVP-40466-CV/NB-Ctrls 1B & 19-SIGN/Car 18-Signing/SS/02/2Adp 6/7/2006 11:29:57 AM

STATE OF ILLINOIS
DEPARTMENT OF TRANSPORTATION

ROUTE NO.	SECTION	COUNTY	TOTAL SHEETS	SHEET NO.
F.A.I. RTE. 90/94		COOK	565	264
FED. ROAD DIST. NO. 1	ILLINOIS	FED. AID PROJECT-		
(1818, ETC, 2324, 6-1P) R-10			62301	

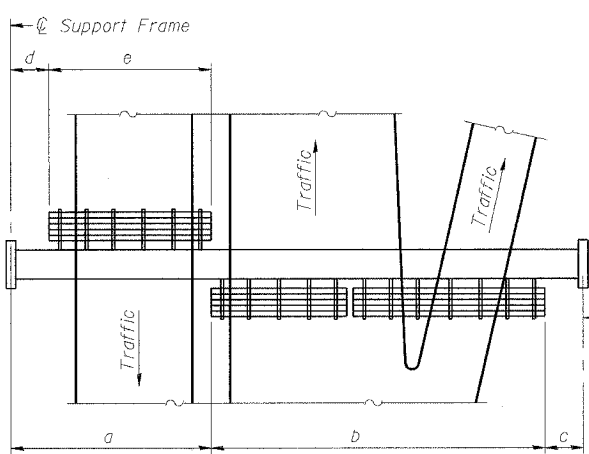

PLAN
WALKWAY AND HANDRAIL SKETCH
(Road plan beneath truss varies)

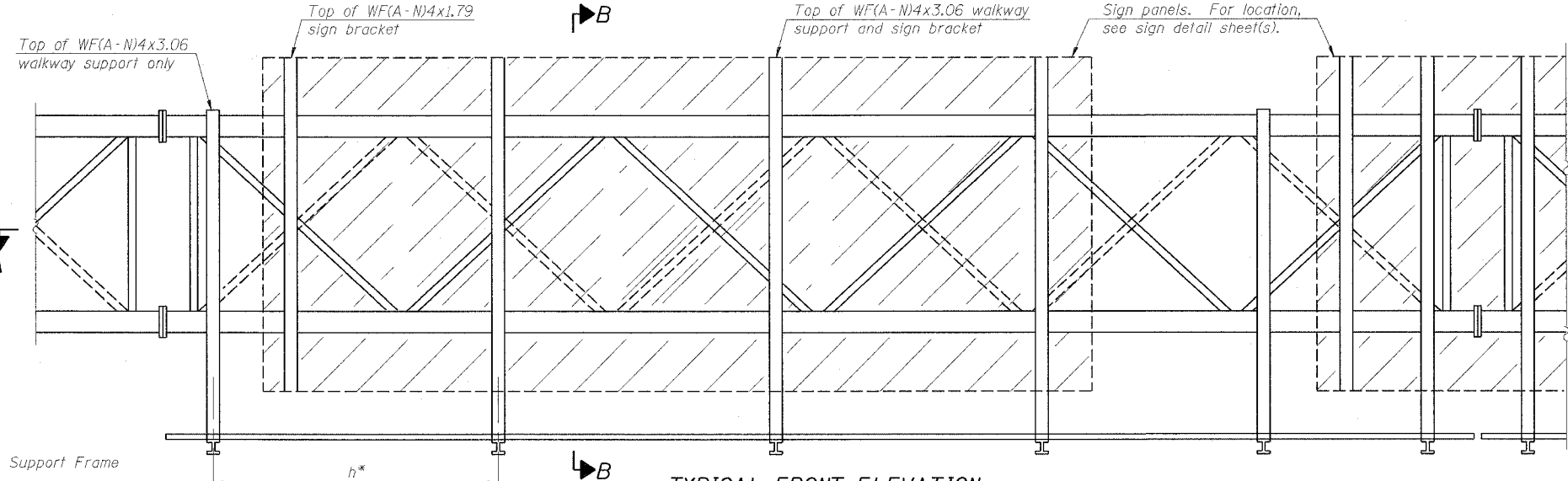

TYPICAL FRONT ELEVATION
With lights and handrail omitted for clarity.
For Section B-B, see Base Sheet 05-A-10.

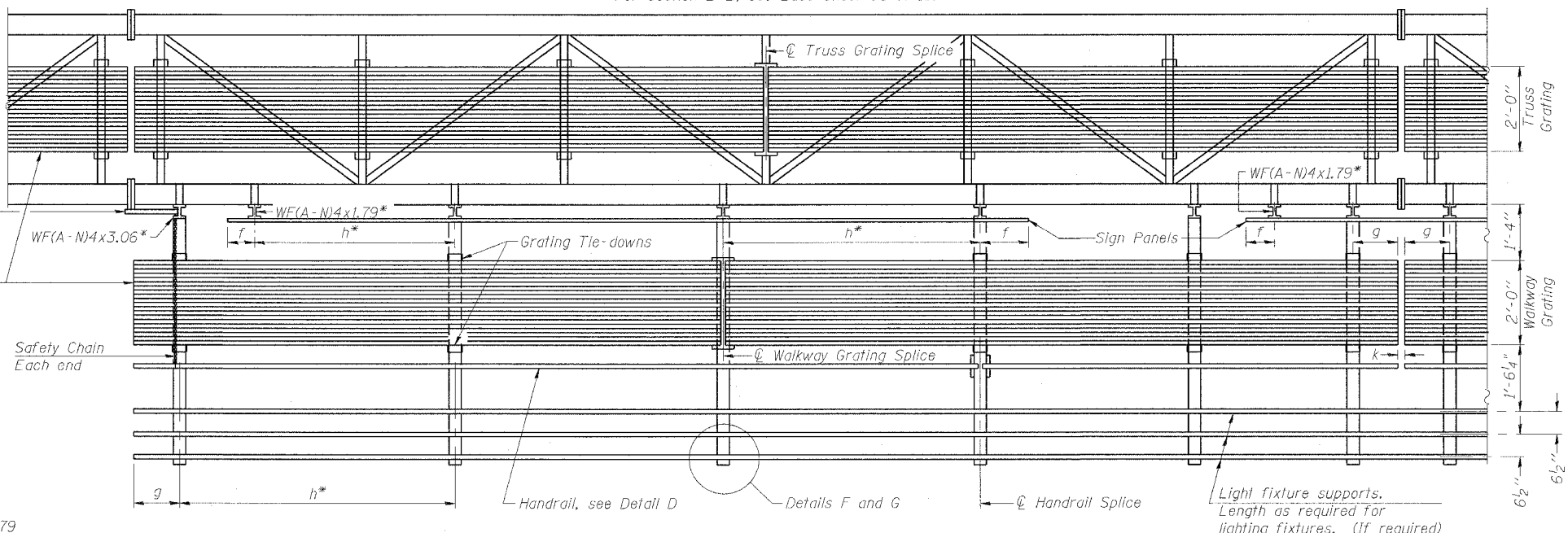

Walkway and Truss Grating width dimensions are nominal and may vary ±1/2" based on available standard widths.

BRACKET TABLE

WF(A-N)4x1.79 or WF(A-N)4x3.06 ASTM B308, Alloy 6061-T6		
Sign Width		Number Brackets Required
Greater Than	Less Than or Equal To	
	8'-0"	2
8'-0"	14'-0"	3
14'-0"	20'-0"	4
20'-0"	26'-0"	5
26'-0"	32'-0"	6

** Alternate angle for safety chain attachment
Standard Aluminum Grating, see Details T and W
Safety Chain Each end

Notes:
* Space walkway brackets WF(A-N)4x3.06 and sign brackets WF(A-N)4x1.79 for efficiency and within limits shown:
f = 12" maximum, 4" minimum (End of sign to center of nearest bracket)
g = 12" maximum, 4" minimum (End of walkway grating to center of nearest support bracket)
h = 6'-0" maximum (center to center of sign and/or walkway support brackets, WF(A-N)4x1.79 or WF(A-N)4x3.06)
k = 2" maximum gap between adjacent walkway grating sections and handrail ends

** If walkway bracket at safety chain location is behind sign, add angle to bracket, see Alternate Safety Chain Attachment on Base Sheet 05-A-11.
For Details T and W, Section B-B and Grating Splice Details, see Base Sheet 05-A-10.
For Details D, F, G and P and Handrail Splice Details, see Base Sheet 05-A-11.

SECTION A-A
Handrail and walkway shall span a minimum of three brackets between splices and/or gap joints. Place all sign and walkway brackets as close to panel points as practical. Grating, handrail and light support splices placed as needed.

Truss grating to facilitate inspection shall run full length (center to center of support frames) ±12" on overhead trusses. Cost of truss grating is included in "Overhead Sign Structure".

Structure Number	Station	a	b	c	d	e	Walkway Grating and Handrail Lengths
ISO161094L057.3	4498+00.00	6.82'	41.00'	17.18'	---	---	41.00'
ISO161094L057.1	4506+75.00	7.36'	48.50'	12.15'	---	---	48.50'
ISO161094L056.9	4518+40.00	34.19'	46.25'	17.56'	---	---	46.25'
ISO161094L056.60	4535+80.00	5.50'	60.50'	8.06'	---	---	60.50'
ISO161094L056.43	4545+35.00	4.83'	56.00'	6.17'	---	---	56.00'
ISO161094L055.94	4571+00.00	4.88'	65.50'	7.63'	---	---	65.50'

DESIGNED - JSS	20
CHECKED - RDP	
DRAWN - JSS	
CHECKED - RDP	

EXAMINED	ENGINEER OF STRUCTURAL SERVICES
PASSED	

NUMBER	REVISION	DATE

OS-A-9 1-7-05

SGN-22

**OVERHEAD SIGN STRUCTURES
ALUMINUM WALKWAY DETAILS**

F.A.I. 90/94 (DAN RYAN EXPRESSWAY)
GARFIELD BLVD TO 31ST STREET (NB LOCAL LANES)
PROPOSED IMPROVEMENT
GARFIELD BLVD TO 31ST STREET

6/7/2006 11:30:43 AM P:\44468 Chn\B Chrs 18 & 19\Sign\Chn 18\Sign\SS18022222.dgn

STATE OF ILLINOIS
DEPARTMENT OF TRANSPORTATION

ROUTE NO.	SECTION	COUNTY	TOTAL SHEETS	SHEET NO.
F.A.I. RTE. 90/94		COOK	565	265
FED. ROAD DIST. NO. 1	ILLINOIS	FED. AID PROJECT-		
• (1815, ETC. 2324.6-1P) R-10				62301

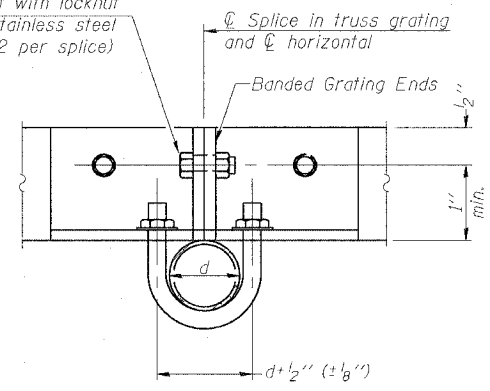
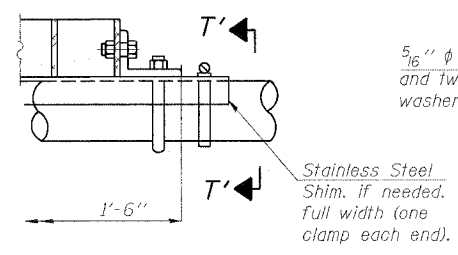
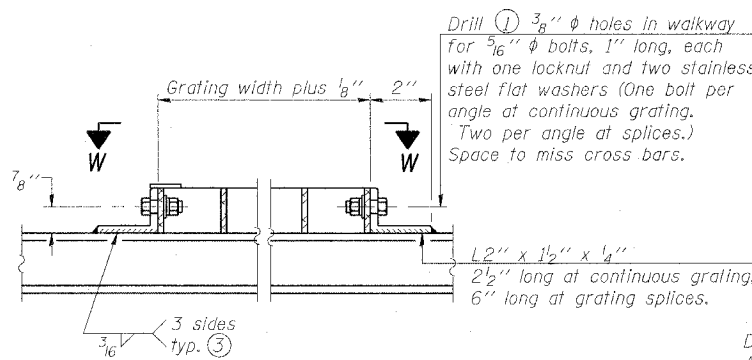
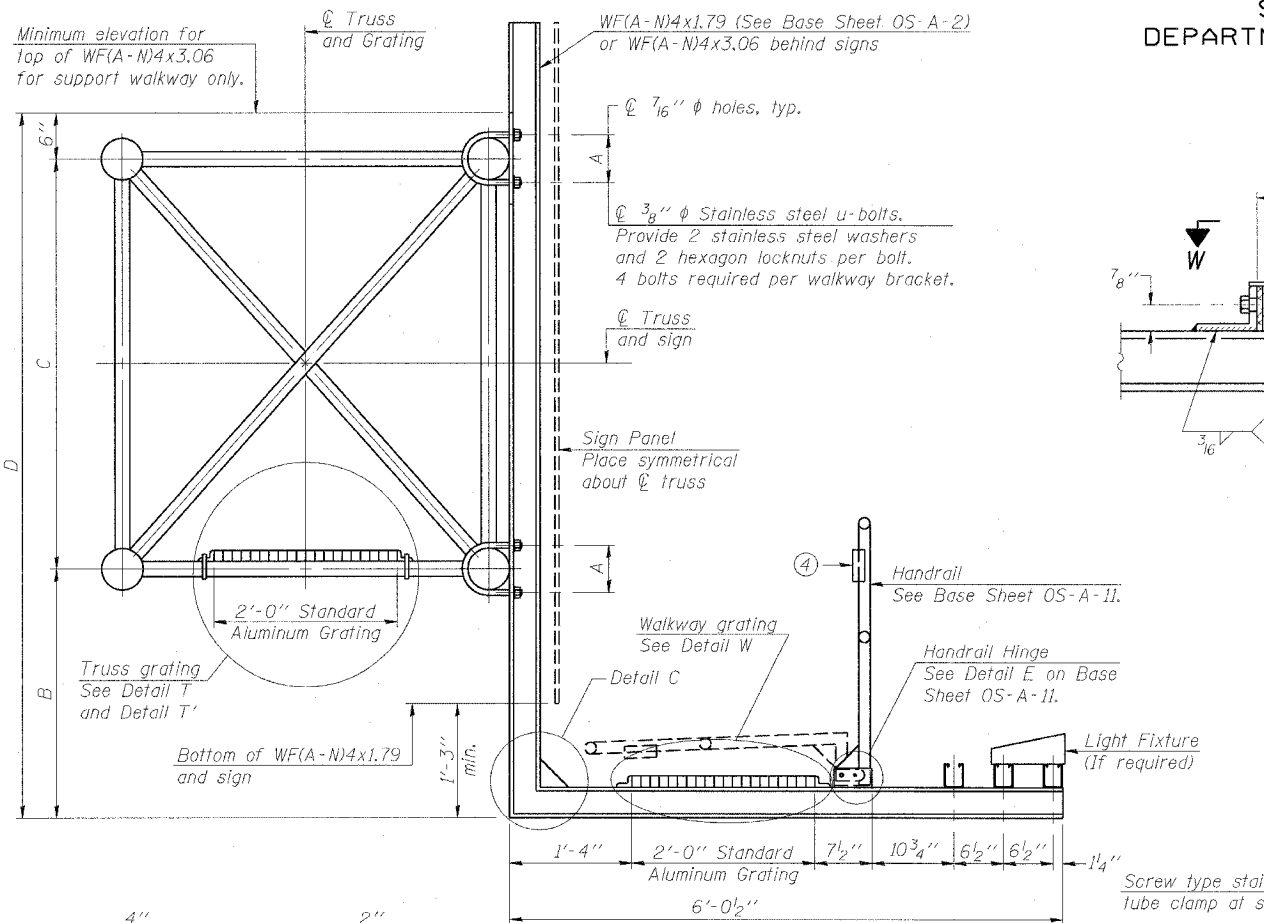

DETAIL W
(Walkway grating)

DETAIL T'
(Truss grating splice)
Details not shown same as Detail T. Alternate materials may be used subject to the Engineer's review and approval.

SECTION T'-T'

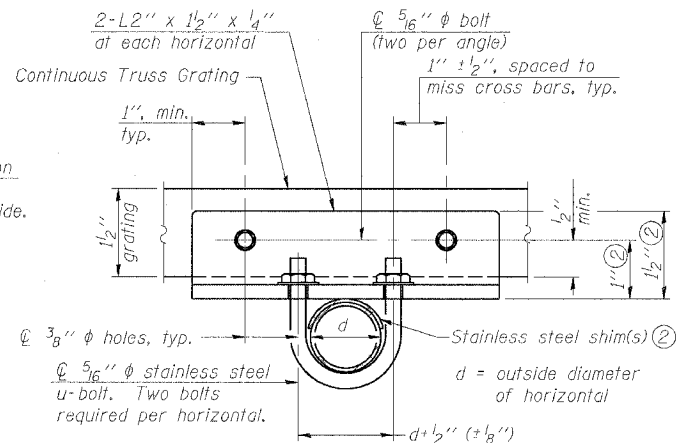
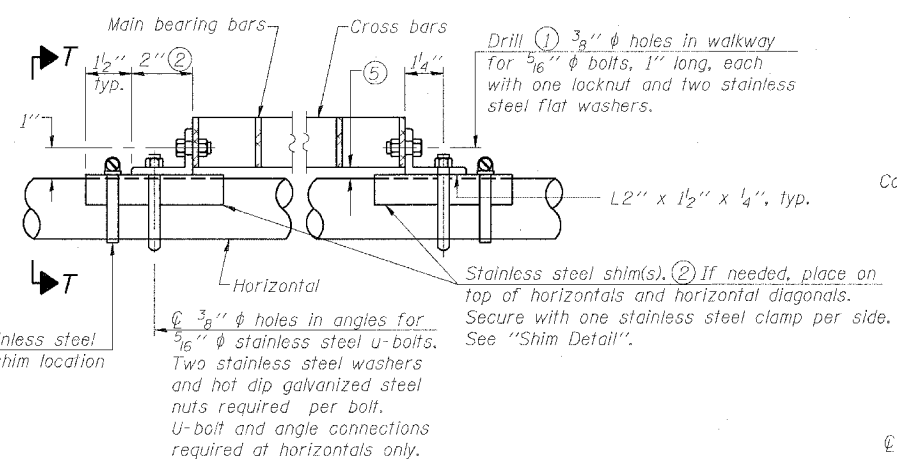

DETAIL T
(Continuous Truss grating)

SECTION T-T

SPECIFICATIONS FOR STANDARD ALUMINUM GRATING

Main Bearing Bars shall be 3/16" x 1 1/2" on 1 3/16" centers and conform to ASTM B221 Alloy 6061-T6.
Cross bars shall be 3/16" x 1 1/2" on 4" centers and conform to ASTM B221 Alloy 6063-T5 or 6061-T6.

OR

Aluminum Grating with modified "I" sections for main bearing bars shall meet the following requirements:
Main bars shall conform to ASTM B221 Alloy 6061-T6 and have a minimum section modulus equal to 0.0705 in.³ per bar, a depth of 1 1/2", spaced on 1 3/16" centers.
Cross bars shall conform to ASTM B221 Alloy 6063-T5 or T-42 and spaced on 4" centers.

Structure Number	Station	A	B	C	D
ISO161094L057.3	4498+00	5 1/2"	3'-0"	4'-6"	8'-0"
ISO161094L057.1	4506+75	5 1/2"	5'-3"	4'-6"	10'-3"
ISO161094L056.9	4518+40	6 1/2"	3'-0"	4'-6"	8'-0"
ISO161094L056.60	4535+80	5 1/2"	5'-3"	4'-6"	10'-3"
ISO161094L056.43	4545+35	5 1/2"	3'-3"	4'-6"	8'-3"
ISO161094L055.94	4571+00	5 1/2"	3'-9"	4'-6"	8'-9"

SECTION B-B

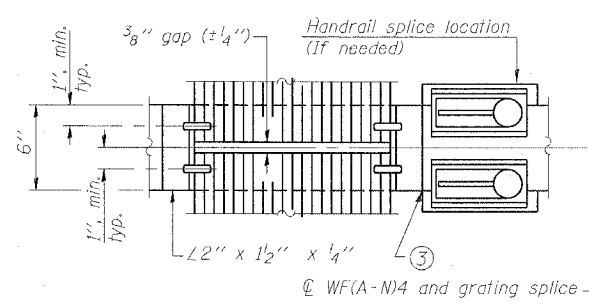

(AT WALKWAY GRATING SPLICE)

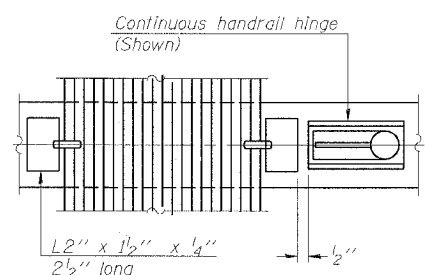

SECTION W-W
(CONTINUOUS WALKWAY GRATING)

SECTION C-C

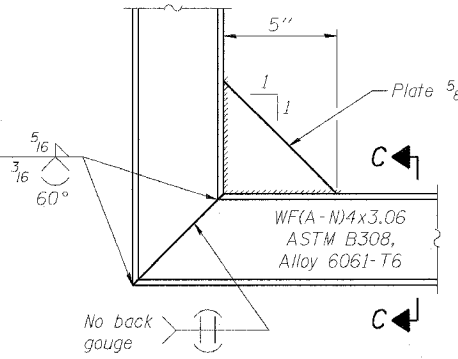
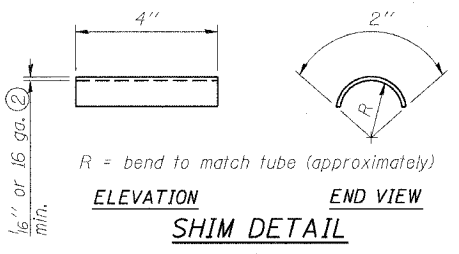
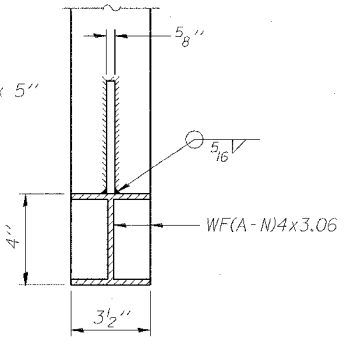

DETAIL C
(See Detail P, Base Sheet OS-A-11.)

DESIGNED	JSS
CHECKED	RDP
DRAWN	JSS
CHECKED	RDP

EXAMINED	20
PASSED	

ENGINEER OF STRUCTURAL SERVICES

ENGINEER OF BRIDGES AND STRUCTURES

NUMBER	REVISION	DATE

SGN-23

**OVERHEAD SIGN STRUCTURES
ALUMINUM WALKWAY DETAILS**

F.A.I. 90/94 (DAN RYAN EXPRESSWAY)
GARFIELD BLVD TO 31ST STREET (NB LOCAL LANES)
PROPOSED IMPROVEMENT
GARFIELD BLVD TO 31ST STREET

F.A.I. 90/94 (DAN RYAN EXPRESSWAY) GARFIELD BLVD TO 31ST STREET (NB LOCAL LANES) PROPOSED IMPROVEMENT GARFIELD BLVD TO 31ST STREET 6/7/2006 10:30 AM

STATE OF ILLINOIS
DEPARTMENT OF TRANSPORTATION

ROUTE NO.	SECTION	COUNTY	TOTAL SHEETS	SHEET NO.
F.A.I. RTE. 90/94		COOK	565	266
FED. PROJ. DIST. NO.	ILLINOIS	FED. AID PROJECT		
(1818, ETC, 2324.6-1P) R-10				62301

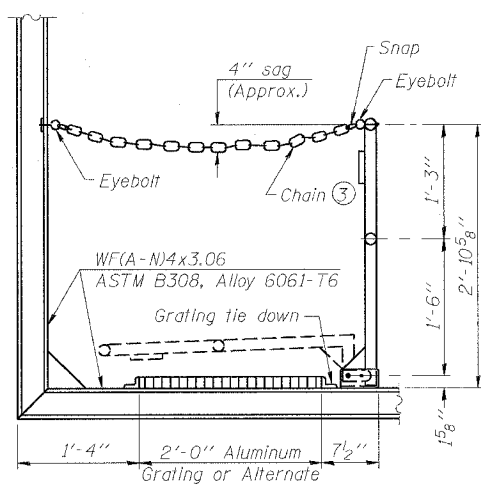

SIDE ELEVATION
(Showing safety chain w/o sign)

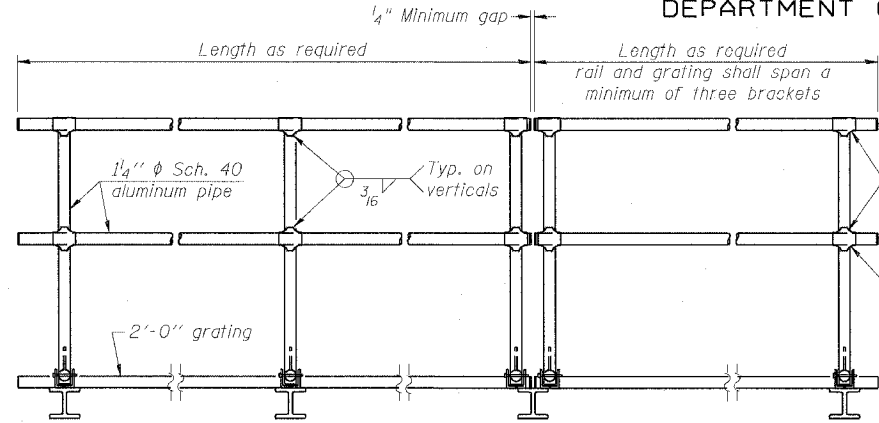

FRONT ELEVATION

HANDRAIL DETAILS

Handrail pipe shall be ASTM B241, Alloy 6063-T6 or Alloy 6061-T6.

- ① Install standard force-fit end caps or weld 1/8" end plates with 1/8" c.f.w. and grind smooth. (All rail ends)
- ② Horizontal handrail member shall be continuous thru fitting. Provide 1/16" hole in fitting for 3/8" bolt. Field drill 1/16" hole in horizontal rail member. Provide locknut and two stainless steel washers for bolt. (Use 5/16" eyebolts in 1/16" holes on top rail at ends only.)

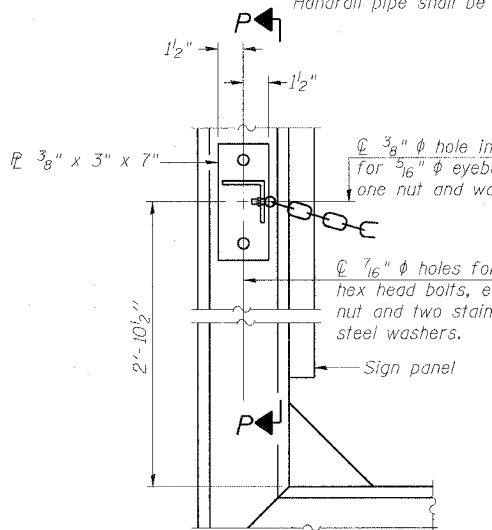

ALTERNATE SAFETY CHAIN ATTACHMENT
(With Sign Present)

Items not shown same as "Side Elevation" of "Handrail Details"

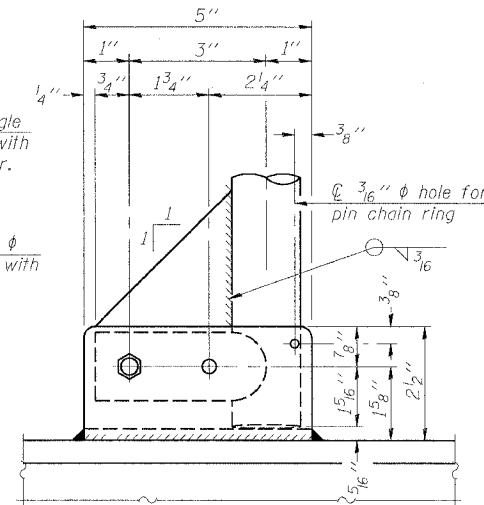

SIDE ELEVATION

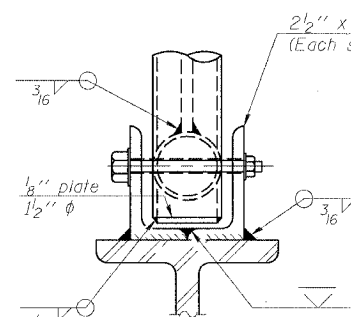

FRONT ELEVATION

See "Elevation" at right for dimensions.

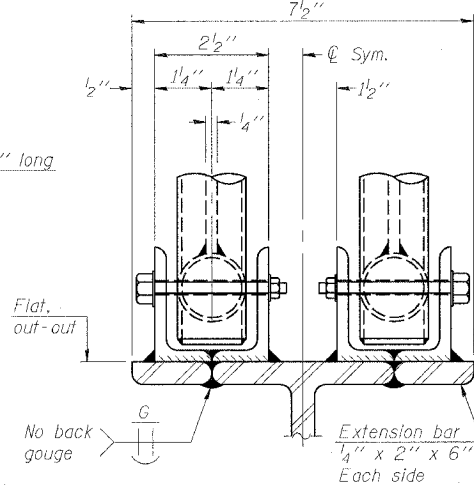

ELEVATION AT HANDRAIL JOINT ④

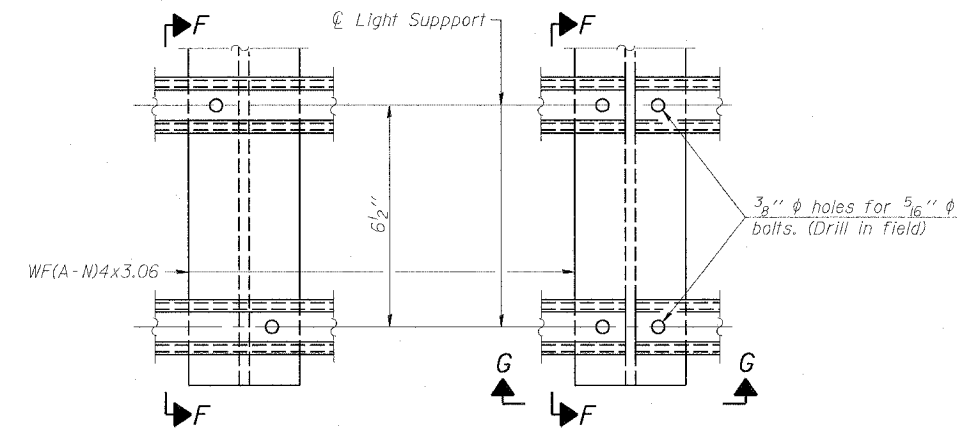

DETAIL F

DETAIL G

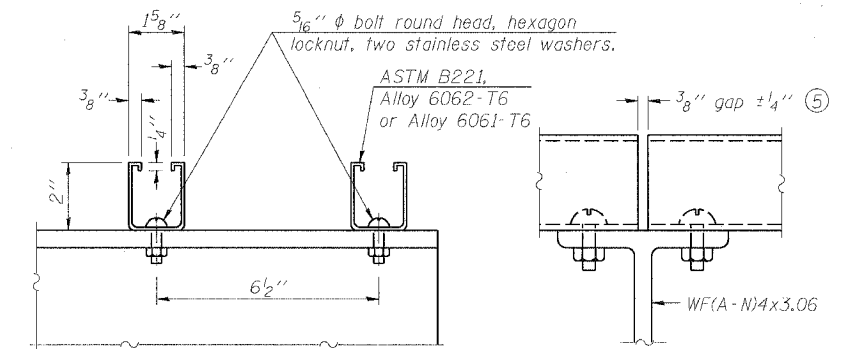

SECTION F-F

SECTION G-G

LIGHTING FIXTURE MOUNTS (IF REQUIRED)

- ⑤ Field cut ends of light support channels shall be free of burrs or hazardous projections and coated with zinc-rich primer or equivalent.

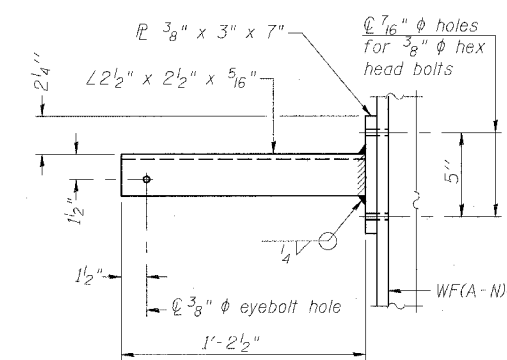

SECTION P-P

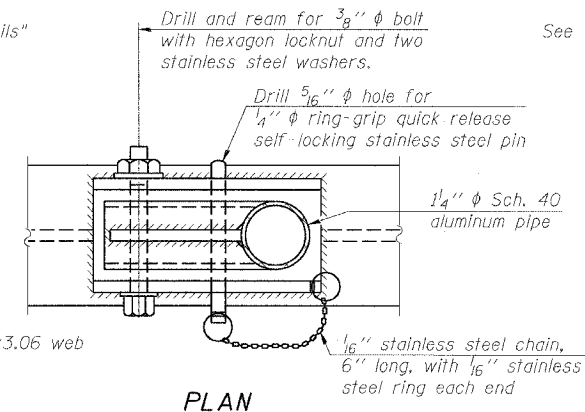

PLAN DETAIL E HANDRAIL HINGE

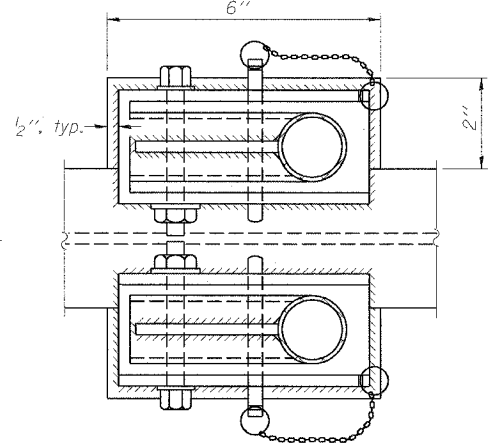

PLAN AT HANDRAIL JOINT

Details not shown same as "PLAN"

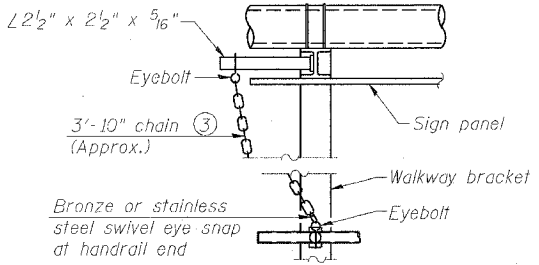

ALTERNATE SAFETY CHAIN ATTACHMENT

Details not shown similar to "Safety Chain" Details (Walkway omitted for clarity)

- ③ 3/16" galvanized steel chain, approximately 12 links per foot. Chain to be hot dip galvanized after manufacture and suitable for prolonged exterior exposure. Alternate materials may be substituted with the Engineer's approval.
- ④ Extrusions may be used in lieu of the details shown, with approval of the Engineer.

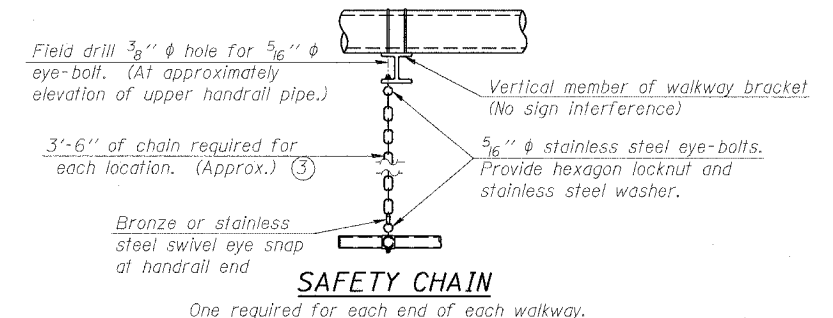

SAFETY CHAIN

One required for each end of each walkway.

DESIGNED - JSS	20
CHECKED - RDP	EXAMINED
DRAWN - JSS	PASSED
CHECKED - RDP	ENGINEER OF STRUCTURAL SERVICES
	ENGINEER OF BRIDGES AND STRUCTURES

NUMBER	REVISION	DATE

OS-A-11 1-7-05

SGN-24

**OVERHEAD SIGN STRUCTURES
ALUMINUM HANDRAIL DETAILS**

F.A.I. 90/94 (DAN RYAN EXPRESSWAY)
GARFIELD BLVD TO 31ST STREET (NB LOCAL LANES)
PROPOSED IMPROVEMENT
GARFIELD BLVD TO 31ST STREET

6/7/2006 11:30:41 AM

STATE OF ILLINOIS
DEPARTMENT OF TRANSPORTATION

ROUTE NO.	SECTION	COUNTY	TOTAL SHEETS	SHEET NO.
94/90		COOK	565	267
FED. ROAD DIST. NO. 1		ILLINOIS	FED. AID PROJECT	

* 62301 (2021-922 PT2 ETC 2324.6-1P) R-10

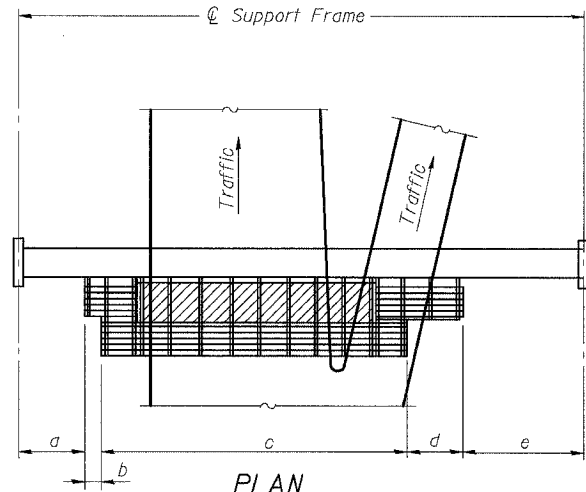

PLAN
WALKWAY AND HANDRAIL SKETCH
(Road plan beneath truss varies)

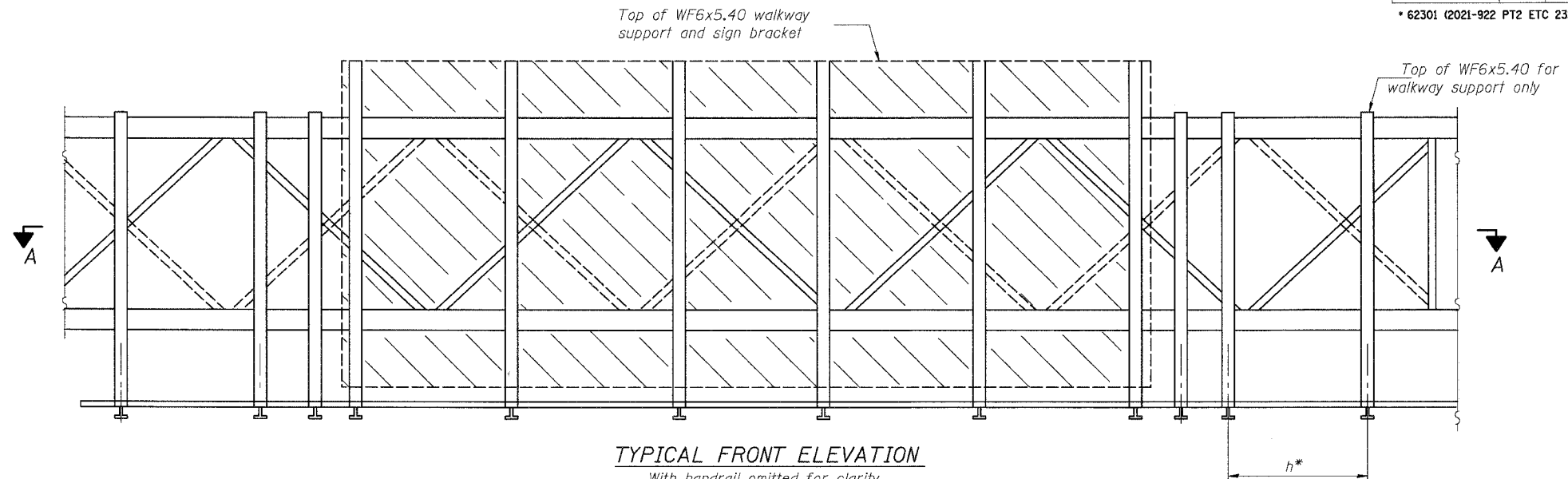

TYPICAL FRONT ELEVATION
With handrail omitted for clarity.
For Section B-B, see Base Sheet OS-A-10-DMS2
For Section B'-B', and B''-B'', see Base Sheet OS-A-10a-DMS2

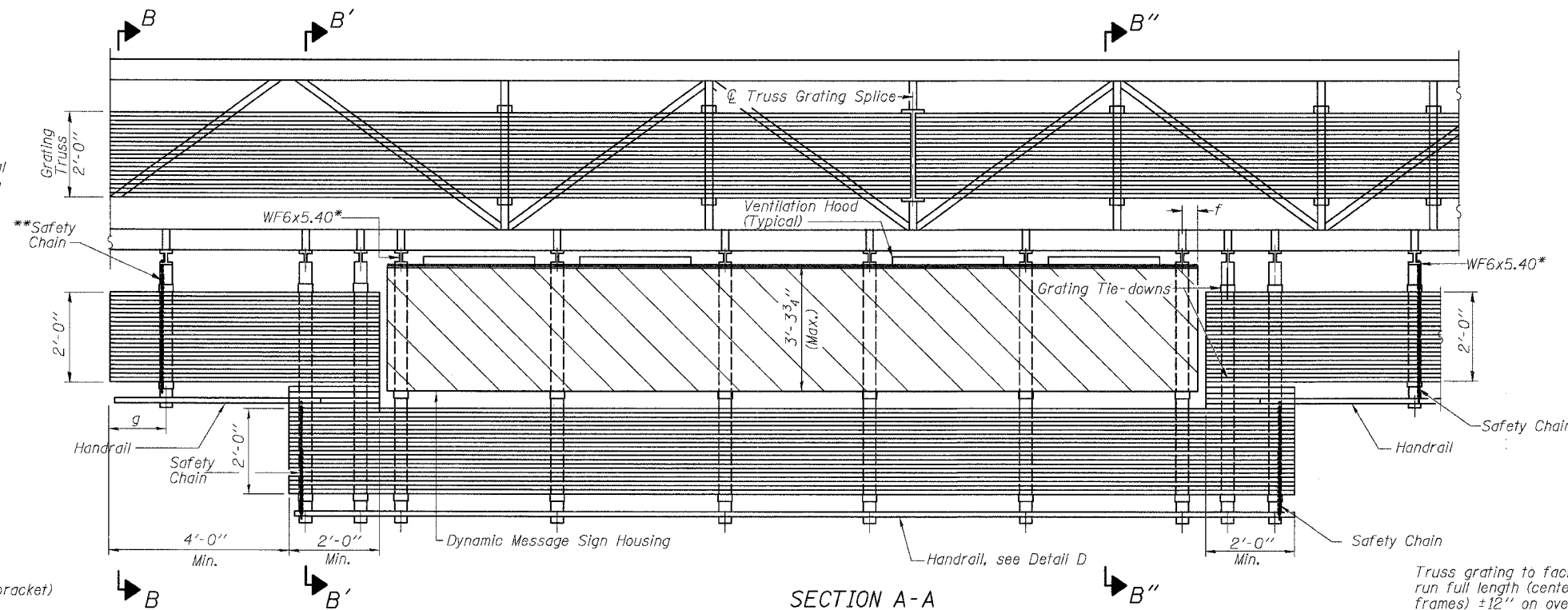

SECTION A-A

Walkway and Truss Grating width dimensions are nominal and may vary $\pm 1/2$ " based on available standard widths.

BRACKET TABLE

WF6x5.40 ASTM B308, Alloy 6061-T6	
Sign Width	Number Brackets Required
26'-1"	6

Notes: *Space WF6x5.40 brackets for efficiency and within limits shown:

f = 12" maximum, 4" minimum (End of sign to ϕ of nearest bracket)

g = 12" maximum, 4" minimum (End of walkway grating to ϕ of nearest support bracket)

h = 6'-0" maximum (ϕ to ϕ or walkway support brackets, WF6x5.40)

**If walkway bracket at safety chain location is behind sign, add angle to bracket, see Alternate Safety Chain Attachment on Base Sheet OS-A-11-DMS2

For Details T and W, Section B-B and Grating Splice Details, see Base Sheet OS-A-10-DMS2.

For Details D, F, G and P and Handrail Splice Details, see Base Sheet OS-A-11-DMS2.

Handrail and walkway shall span a minimum of three brackets between splices and/or gap joints. Place all sign and walkway brackets as close to panel points as practical. Grating and handrail splices placed as needed.

Truss grating to facilitate inspection shall run full length (center to center of support frames) ± 12 " on overhead trusses. Cost of truss grating is included in "Overhead Sign Structure"

SGN-25

OVERHEAD SIGN STRUCTURES
ALTERNATE ALUMINUM WALKWAY DETAILS

ILLINOIS DEPARTMENT OF TRANSPORTATION
F.A.I. 94/90 (DAN RYAN EXPRESSWAY)
GARFIELD BLVD TO 31ST STREET (NB LOCAL LANES)
OVERHEAD SIGN STRUCTURES
(SPAN)

DESIGNED	- JSS
CHECKED	- MJP
DRAWN	- JSS
CHECKED	- MJP

20	EXAMINED
	ENGINEER OF STRUCTURAL SERVICES
	PASSED
	ENGINEER OF BRIDGES AND STRUCTURES

NUMBER	REVISION	DATE

Structure Number	Station	a	b	c	d	e	Walkway Grating and Handrail Lengths
1S0161094L055.41	4599+00	2'-9"	4.0'	30'-3"	15'-10"	17'-2"	50'-1"

OS-A-9-DMS2 7/1/2001

6/7/2006 1:50:48 PM

STATE OF ILLINOIS
DEPARTMENT OF TRANSPORTATION

ROUTE NO.	COUNTY	JOIN. SHEETS	SHEET NO.
94/90	COOK	565	268
FED. ROAD DIST. NO. 1	ILLINOIS	FED. AID PROJECT-	

* 62301 (2021-922 PT2 ETC 2324.6-1P) R-10

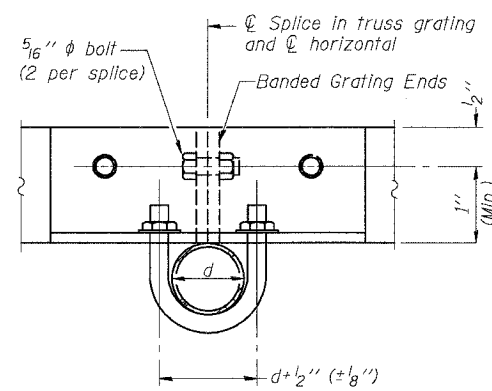
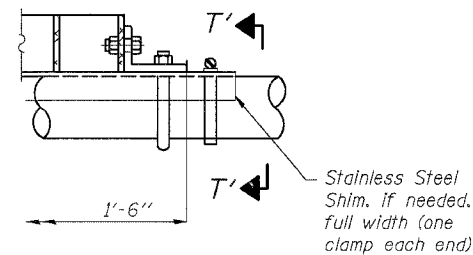
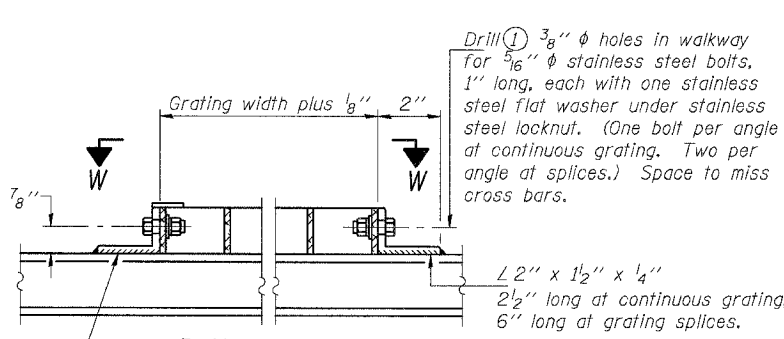
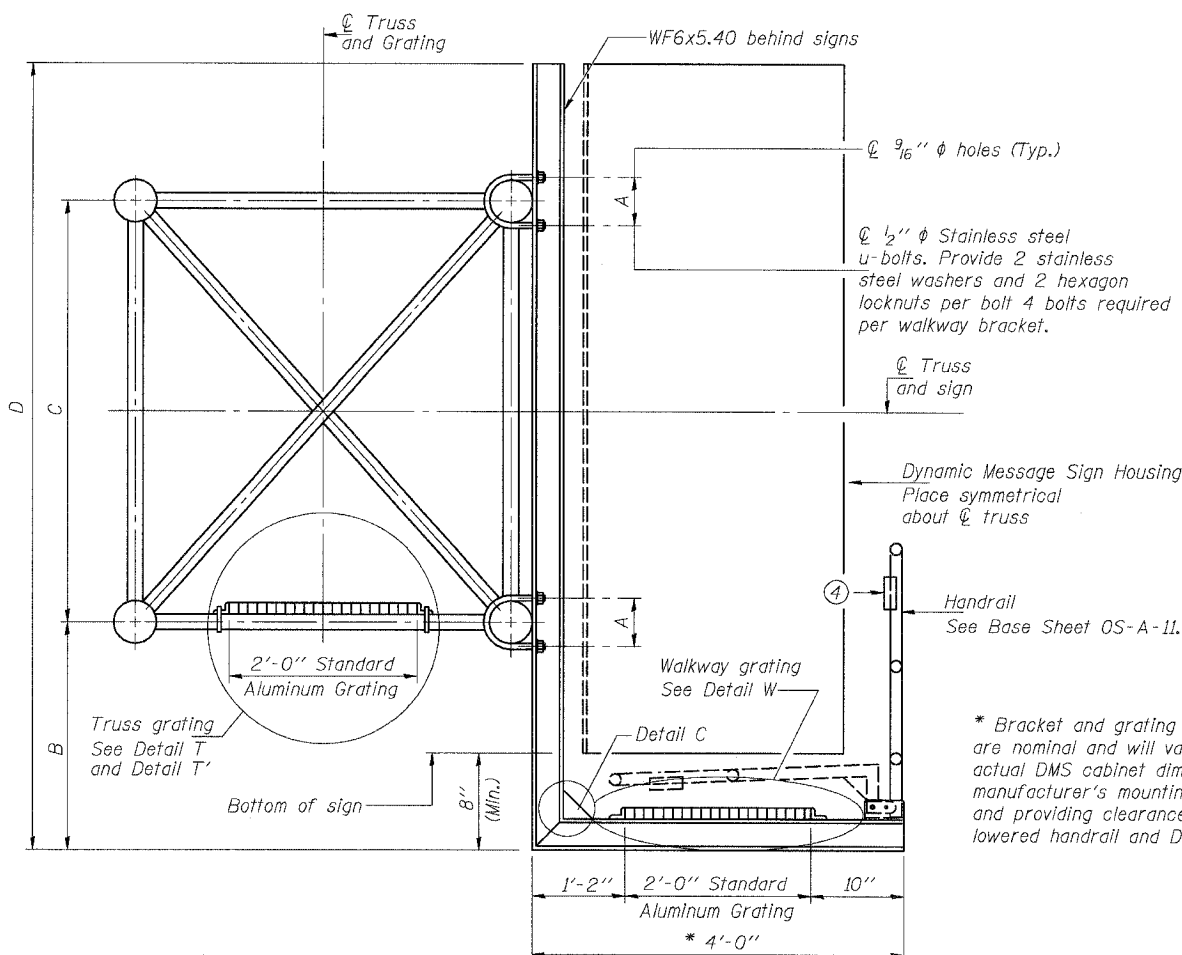

DETAIL W
(Walkway grating)

DETAIL T'
(Truss grating splice)
Details not shown same as Detail T. Alternate materials may be used subject to the Engineer's review and approval.

SECTION T'-T'

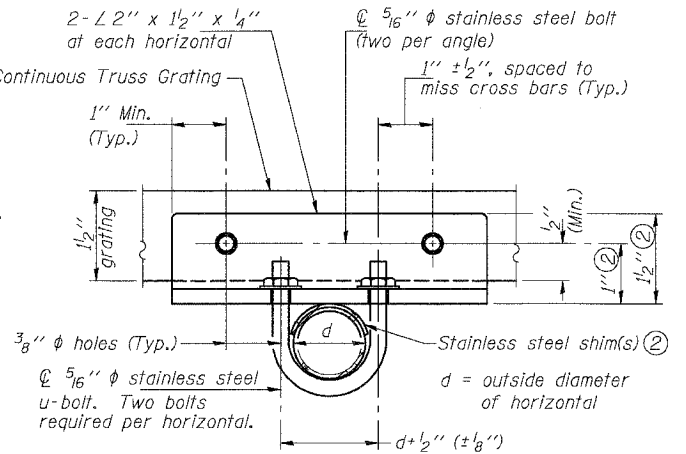
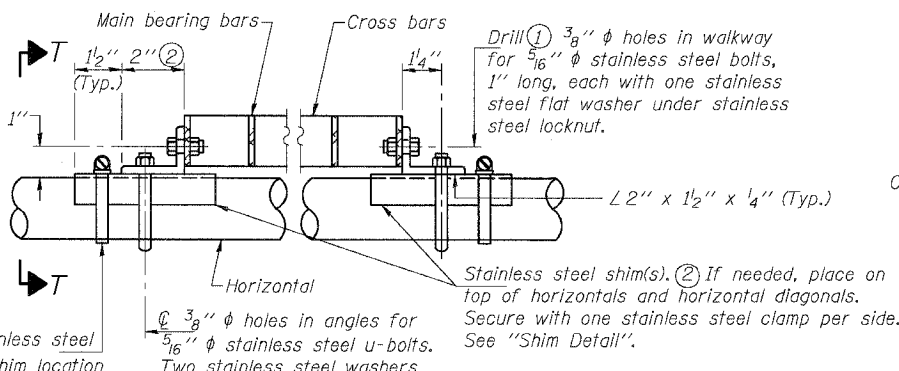

DETAIL T
(Continuous Truss grating)

SECTION T-T

SPECIFICATIONS FOR STANDARD ALUMINUM GRATING

Main Bearing Bars shall be 3/16" x 1/2" on 1 3/16" centers and conform to ASTM B211 Alloy 6061-T6.
Cross bars shall be 3/8" x 1/2" on 4" centers and conform to ASTM B221 Alloy 6063-T5 or 6061-T6.
OR
Aluminum Grating with modified "H" sections for main bearing bars shall meet the following requirements:
Main bars shall conform to ASTM B221 Alloy 6061-T6 and have a minimum section modulus equal to 0.0705 in.³ per bar, a depth of 1 1/2", spaced on 1 3/16" centers.
Cross bars shall conform to ASTM B221 Alloy 6063-T5 or T-42 and spaced on 4" centers.

- Drilling holes in grating may be done in shop or field, based on Contractor's preference and subject to accurate alignment.
- Stainless steel shims shall be placed as shown in Detail T if needed to compensate for alignment variations between horizontal and diagonal pipes beyond adjustment provided by angles. Thicker shims may be used subject to shims performing properly.
- If Handrail Joint present, weld angle to WF6 and 1/4" extension bars. (See Base Sheet OS-A-11-DMS2.)
- 1/8" x 1/2" x 2" welded to handrail posts to protect locations that contact grating.

SECTION B-B

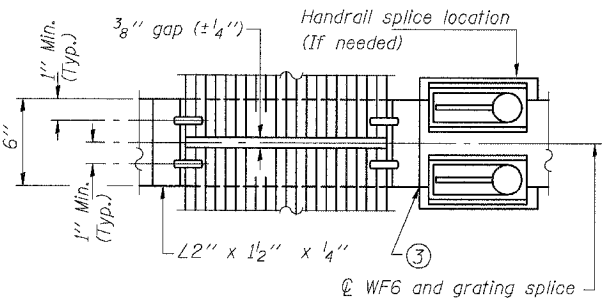

(AT WALKWAY GRATING SPLICE)

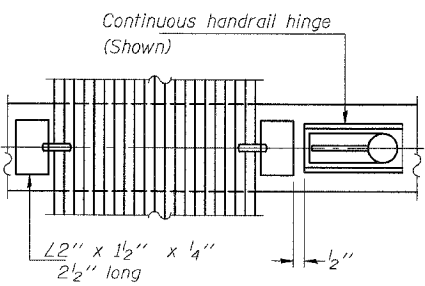

(CONTINUOUS WALKWAY GRATING)

SECTION W-W

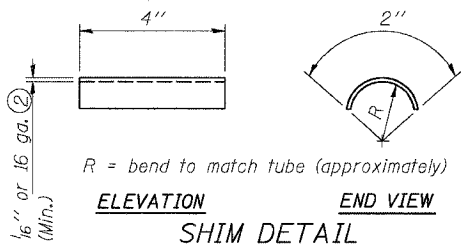

SHIM DETAIL

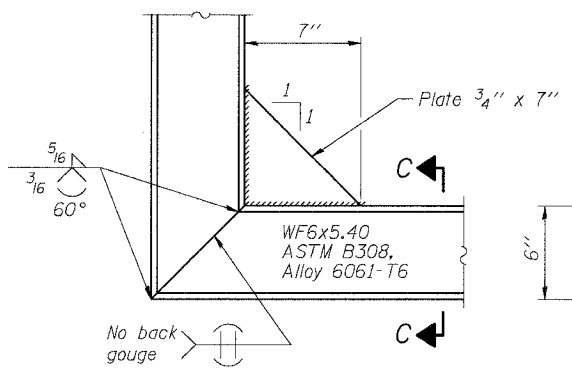

DETAIL C

SECTION C-C

DESIGNED	- JSS
CHECKED	- MJP
DRAWN	- JSS
CHECKED	- MJP

EXAMINED	20
PASSED	

NUMBER	REVISION	DATE

Structure Number	Station	A	B	C	D
ISO16T094L055.41	4599+00	7 1/2"	2'-0"	7'-0"	9'-9"

OVERHEAD SIGN STRUCTURES
ALTERNATE ALUMINUM WALKWAY DETAILS
ILLINOIS DEPARTMENT OF TRANSPORTATION
F.A.I. 94/90 (DAN RYAN EXPRESSWAY)
GARFIELD BLVD TO 31ST STREET (NB LOCAL LANES)
OVERHEAD SIGN STRUCTURES
(SPAN)

6/7/2006 1:50:52 PM

STATE OF ILLINOIS
DEPARTMENT OF TRANSPORTATION

ROUTE NO.		COUNTY	TOTAL SHEETS	SHEET NO.
94/90	*	COOK	565	269
FED. ROAD DIST. NO. 1		ILLINOIS	FED. AID PROJECT-	

* 62301 (2021-922 PT2 ETC 2324.6-1P) R-10

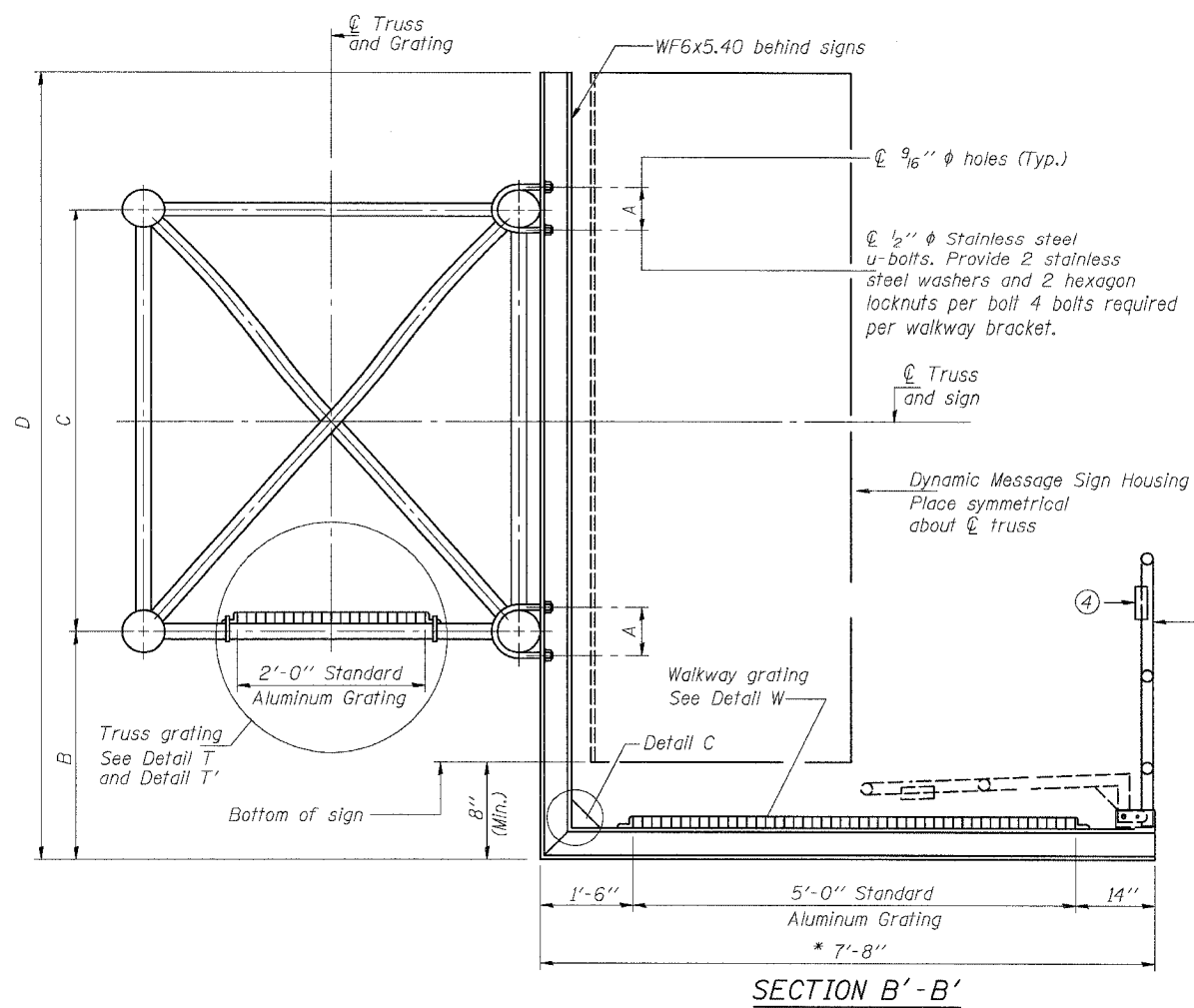

SECTION B'-B'

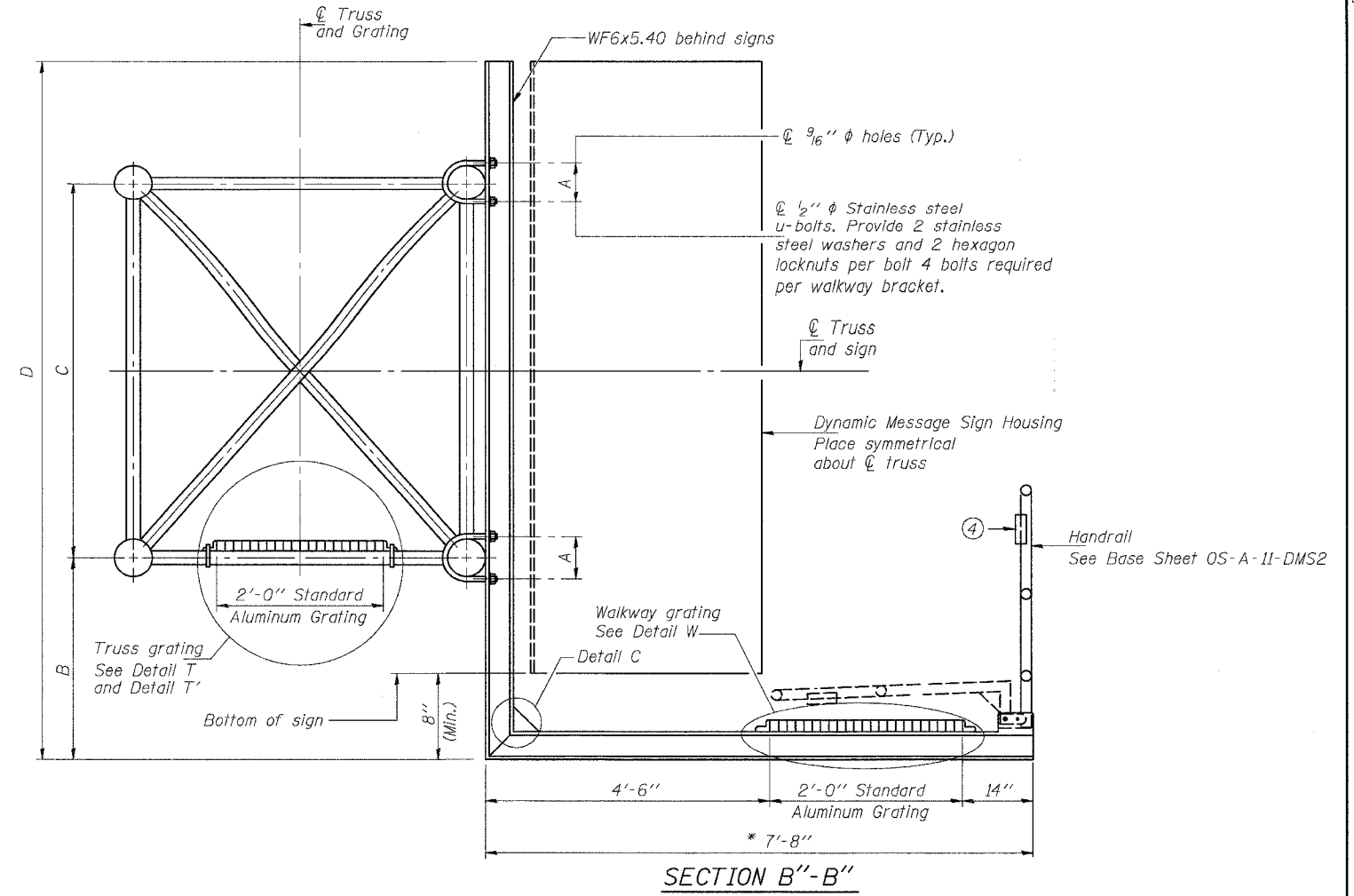

SECTION B''-B''

* Bracket and grating dimensions are nominal and will vary based on actual DMS cabinet dimensions plus manufacturer's mounting devices, and providing clearance between the lowered handrail and DMS cabinet.

Note:
For dimensions "A" to "D" and remaining details, see sheet OS-A-10-DMS2

DESIGNED - JSS	20
CHECKED - MJP	EXAMINED
DRAWN - JSS	PASSED
CHECKED - MJP	

ENGINEER OF STRUCTURAL SERVICES
ENGINEER OF BRIDGES AND STRUCTURES

NUMBER	REVISION	DATE

OS-A-10a-DMS2 7/1/2001

OVERHEAD SIGN STRUCTURES
ALTERNATE ALUMINUM WALKWAY DETAILS

ILLINOIS DEPARTMENT OF TRANSPORTATION
F.A.I. 94/90 (DAN RYAN EXPRESSWAY)
GARFIELD BLVD TO 31ST STREET (NB LOCAL LANES)

OVERHEAD SIGN STRUCTURES
(SPAN)

SGN-27

6/7/2006 1:50:52 PM In:\660\road\civil\118\shp\sgn\sgn10202a.dwg

STATE OF ILLINOIS
DEPARTMENT OF TRANSPORTATION

ROUTE NO.	SECTION	COUNTY	SHEET	SHEET
F.A.I. RTE. 90/94		COOK	565	270
FED. ROAD DIST. NO. 1	ILLINOIS	FED. AID PROJECT-		

62301 (2021-922 PT2 ETC 2324.6-1P) R-10

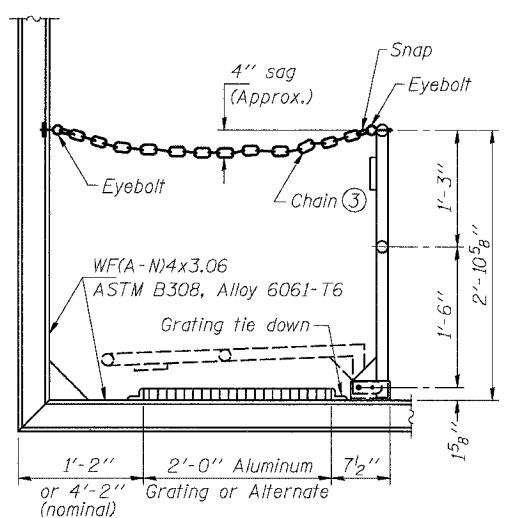

SIDE ELEVATION

(Showing safety chain w/o sign)

HANDRAIL DETAILS

Handrail pipe shall be ASTM B241, Alloy 6063-T6 or Alloy 6061-T6.

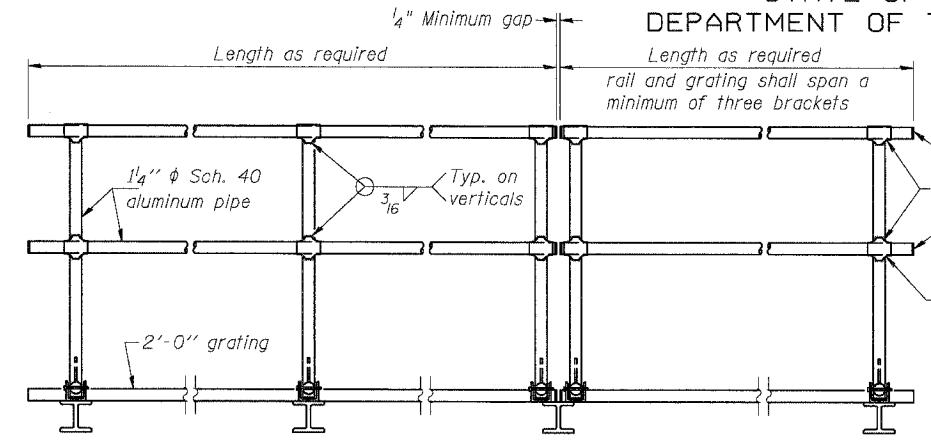

FRONT ELEVATION

① Install standard force-fit end caps or weld 1/8" end plates with 1/8" c.f.w. and grind smooth. (All rail ends)

② Horizontal handrail member shall be continuous thru fitting. Provide 7/16" hole in fitting for 3/8" bolt. Field drill 7/16" hole in horizontal rail member. Provide washer and locknut for bolt. (Use 5/16" eyebolts in 7/16" holes on top rail at ends only.)

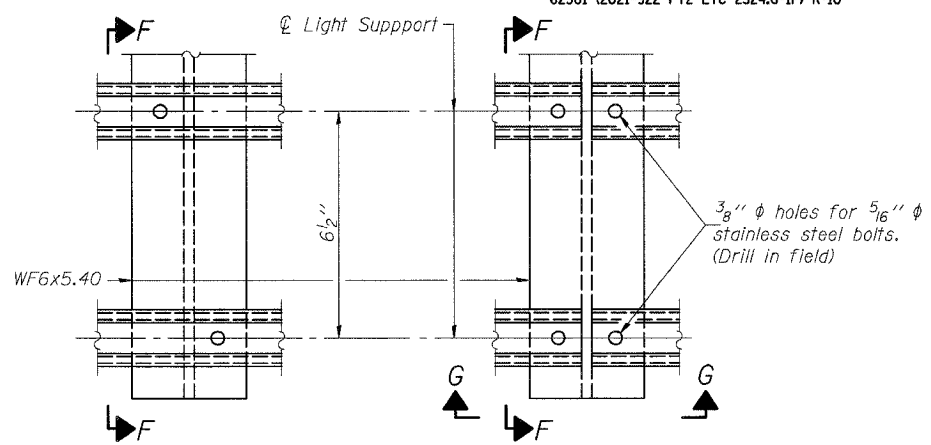

DETAIL F

DETAIL G

SECTION F-F

SECTION G-G

LIGHTING FIXTURE MOUNTS (IF REQUIRED)

⑤ Field cut ends of light support channels shall be free of burrs or hazardous projections and coated with zinc-rich primer or equivalent.

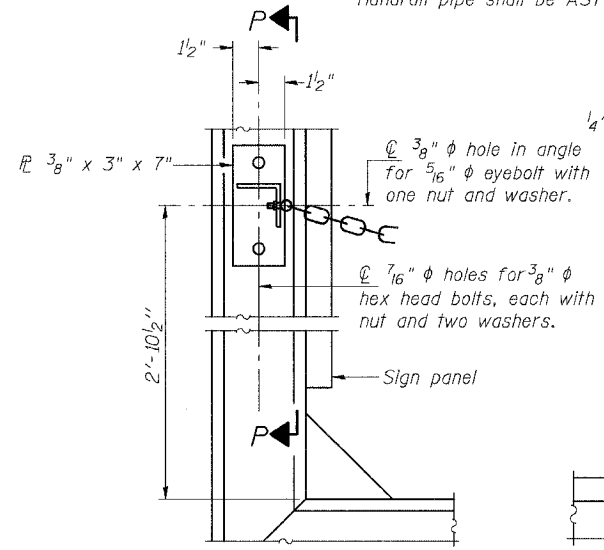

ALTERNATE SAFETY CHAIN ATTACHMENT

(With Sign Present)

Items not shown same as "Side Elevation" of "Handrail Details"

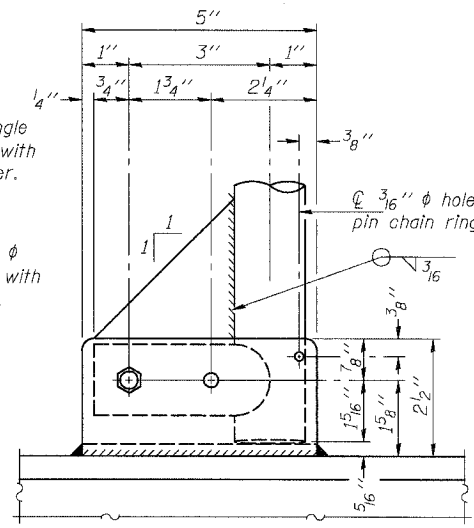

SIDE ELEVATION

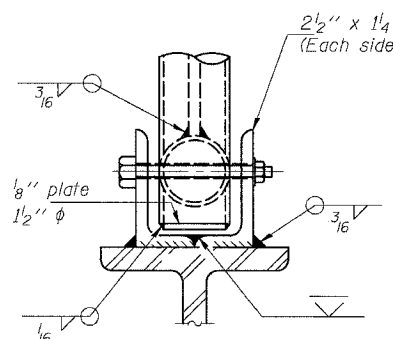

FRONT ELEVATION

See "ELEVATION" at right for dimensions.

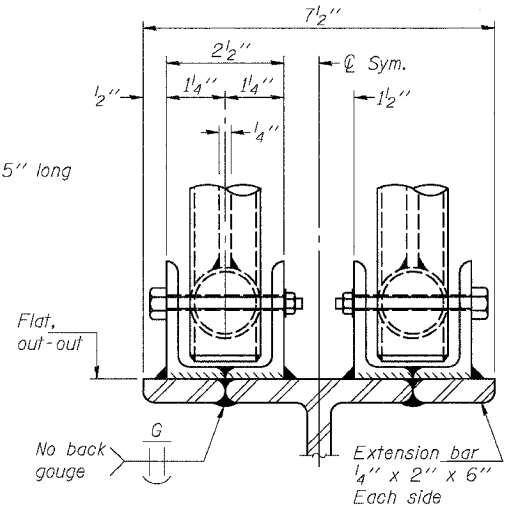

ELEVATION AT HANDRAIL JOINT

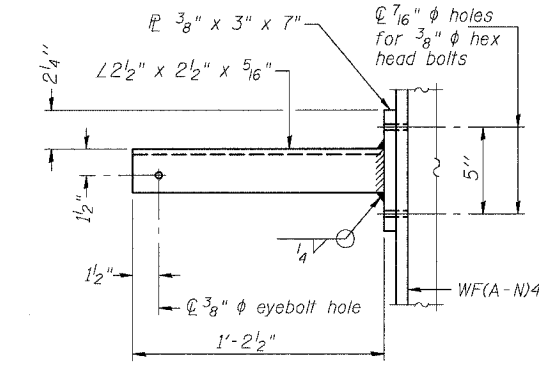

SECTION P-P

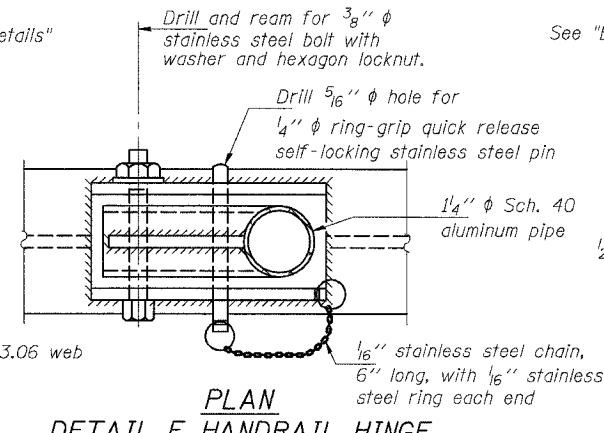

PLAN DETAIL E HANDRAIL HINGE

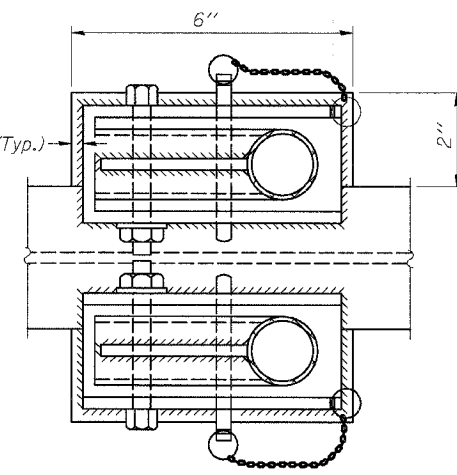

PLAN AT HANDRAIL JOINT

Details not shown same as "PLAN"

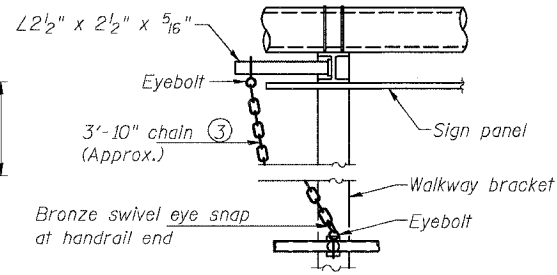

ALTERNATE SAFETY CHAIN ATTACHMENT

Details not shown similar to "Safety Chain" Details (Walkway omitted for clarity)

③ 3/16" galvanized steel chain, approximately 12 links per foot. Chain to be hot dip galvanized after manufacture and suitable for prolonged exterior exposure. Alternate materials may be substituted with the Engineer's approval.

④ Extrusions may be used in lieu of the details shown, with approval of the Engineer.

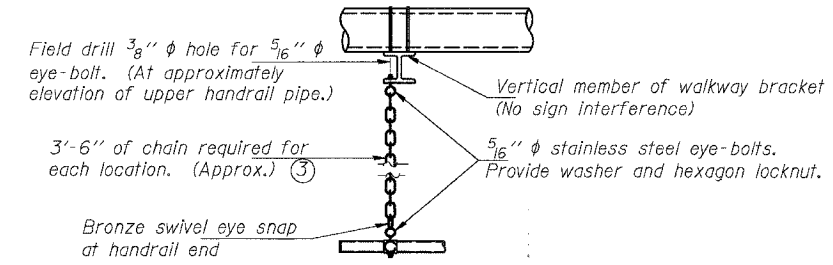

SAFETY CHAIN

One required for each end of each walkway.

DESIGNED	JSS
CHECKED	MJP
DRAWN	JSS
CHECKED	MJP

EXAMINED	20
PASSED	

NUMBER	REVISION	DATE

OVERHEAD SIGN STRUCTURES
ALTERNATE ALUMINUM HANDRAIL DETAILS

ILLINOIS DEPARTMENT OF TRANSPORTATION
F.A.I. 94/90 (DAN RYAN EXPRESSWAY)
GARFIELD BLVD TO 31ST STREET (NB LOCAL LANES)

OVERHEAD SIGN STRUCTURES
(SPAN)

6/7/2006 15:05:33 PM

STATE OF ILLINOIS
DEPARTMENT OF TRANSPORTATION

ROUTE NO.	SECTION	COUNTY	TOTAL SHEETS	SHEET NO.
F.A.I. RTE. 90/94		COOK	565	271
FED. ROAD DIST. NO. 1	ILLINOIS	FED. AID PROJECT		
4818, ETC. 2324,6-1P) R-10				62301

For anchor rod size and placement, see Support Frame Detail Sheet.

* Anchor rod shall be ground or filed to bright metal at clamp and cable connection location.

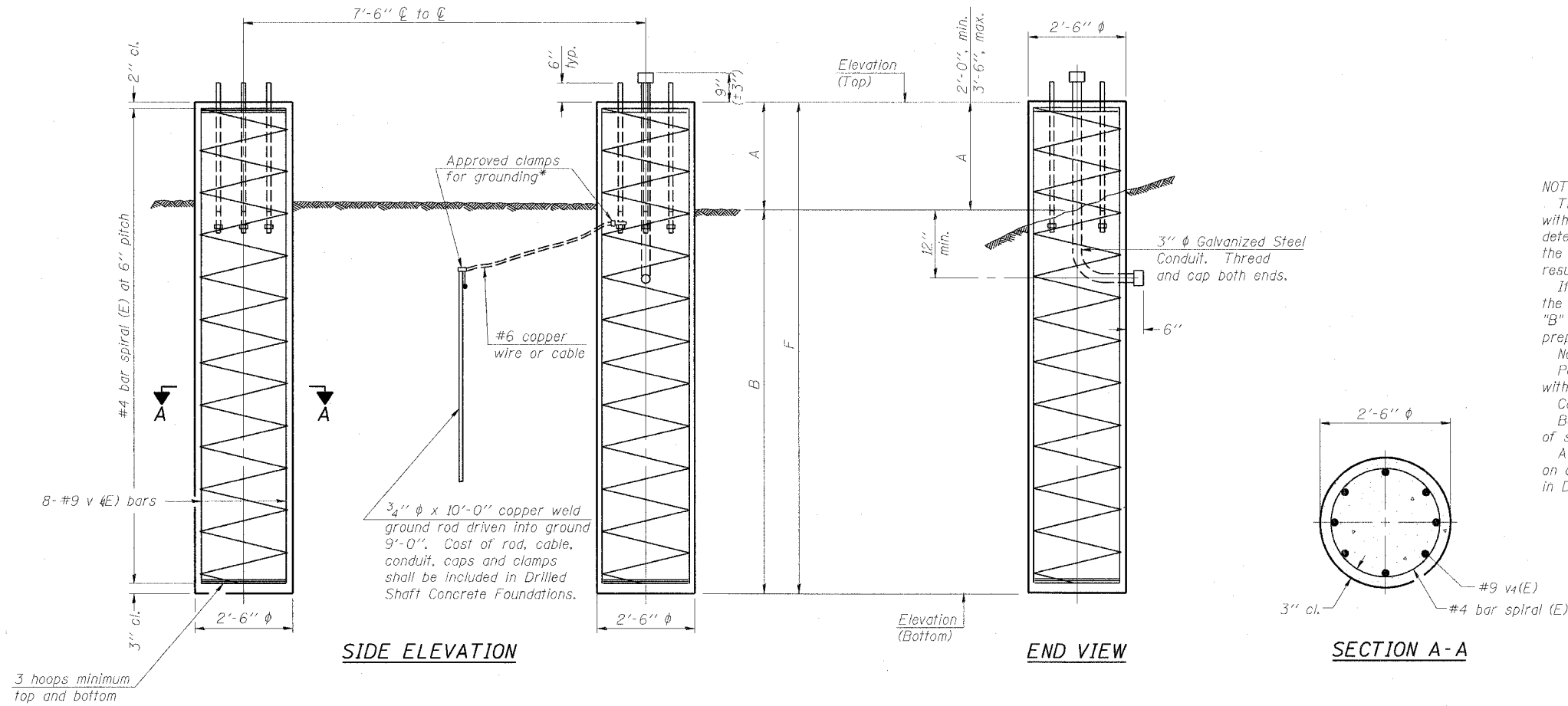

BAR LIST - EACH FOUNDATION

Bar	Number	Size	Length	Shape
v4(E)	16	#9	F less 5"	
#4 bar spiral (E) - see Side Elevation				

NOTES:

The foundation dimensions shown are based on the presence of mostly cohesive soils with an average Unconfined Compressive Strength (Cu) of at least 1.25 tsf, which must be determined by previous soil investigations at the jobsite. When other conditions are indicated, the boring data will be included in the plans and the foundation dimensions shown will be the result of site specific designs.

If the conditions encountered are different than those indicated, the Contractor shall notify the Engineer to determine if the foundation dimensions need to be modified. If dimensions "B" or "F" are revised by more than 12" by the Contractor, "as-built" plans shall be prepared and submitted to the District Bureau of Operations for future reference.

No sonotubes or decomposable forms shall be used below the lower conduit entrance. Permanent metal forms or other shielding may not be left in place below that elevation without the Engineer's written permission.

Concrete shall be placed monolithically, without construction joints.

Backfill shall be placed per Article 502 of Standard Specification and prior to erection of support column.

A normal surface finish followed by a Bridge Seat Sealer application will be required on concrete surfaces above the lowest elevation 6" below finished ground line. Cost included in Drilled Shaft Concrete Foundation.

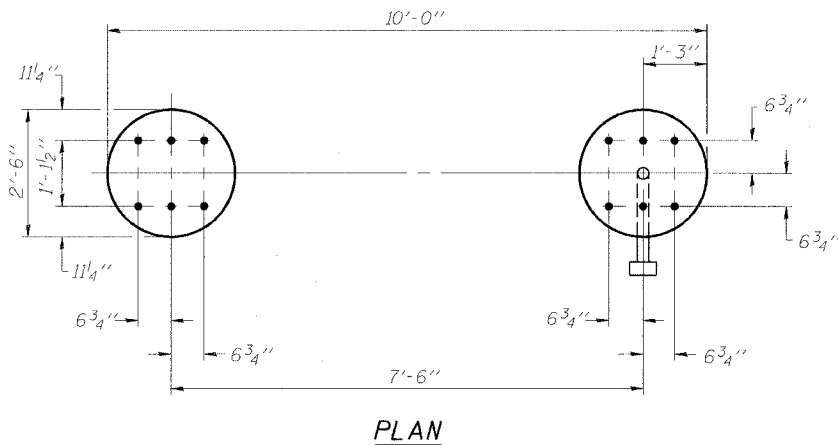

Structure Number	Station	Left Foundation					Right Foundation					Class SI Concrete (Cu. Yds.)
		Elevation Top	Elevation Bottom	A	B	F	Elevation Top	Elevation Bottom	A	B	F	
ISO161094L057.3	4498+00	---	---	---	---	---	8.90'	-6.60'	2.00'	13.50'	15.50'	5.6
ISO161094L057.1	4506+75	---	---	---	---	---	5.66'	-9.84'	2.00'	13.50'	15.50'	5.6
ISO161094L056.43	4545+35	---	---	---	---	---	11.88'	-4.12'	2.50'	13.50'	16.00'	5.8
ISO161094L055.94	4571+00	---	---	---	---	---	1.30'	-15.70'	2.50'	14.50'	17.00'	6.2

DESIGNED	JSS
CHECKED	RDP
DRAWN	JSS
CHECKED	RDP

EXAMINED	20
PASSED	

NUMBER	REVISION	DATE

DETAILS FOR 8" Ø SUPPORT FRAME
TYPE I-A TRUSS

OVERHEAD SIGN STRUCTURES
DRILLED SHAFT DETAILS

F.A.I. 90/94 (DAN RYAN EXPRESSWAY)
GARFIELD BLVD TO 31ST STREET (NB LOCAL LANES)
PROPOSED IMPROVEMENT
GARFIELD BLVD TO 31ST STREET

STATE OF ILLINOIS
DEPARTMENT OF TRANSPORTATION

ROUTE NO.	SECTION	COUNTY	TOTAL SHEETS	SHEET NO.
F.A.I. RTE. 90/94	*	COOK	565	272
FED. ROAD DIST. NO. 1	PLAN NO.	FED. AID PROJECT		
				62301

For anchor rod size and placement, see Support Frame Detail Sheet.

* Anchor rod shall be ground or filed to bright metal at clamp and cable connection location.

BAR LIST - EACH FOUNDATION

Bar	Number	Size	Length	Shape
v4(E)	24	#9	F less 5"	
#4 bar spiral (E) - see Side Elevation				

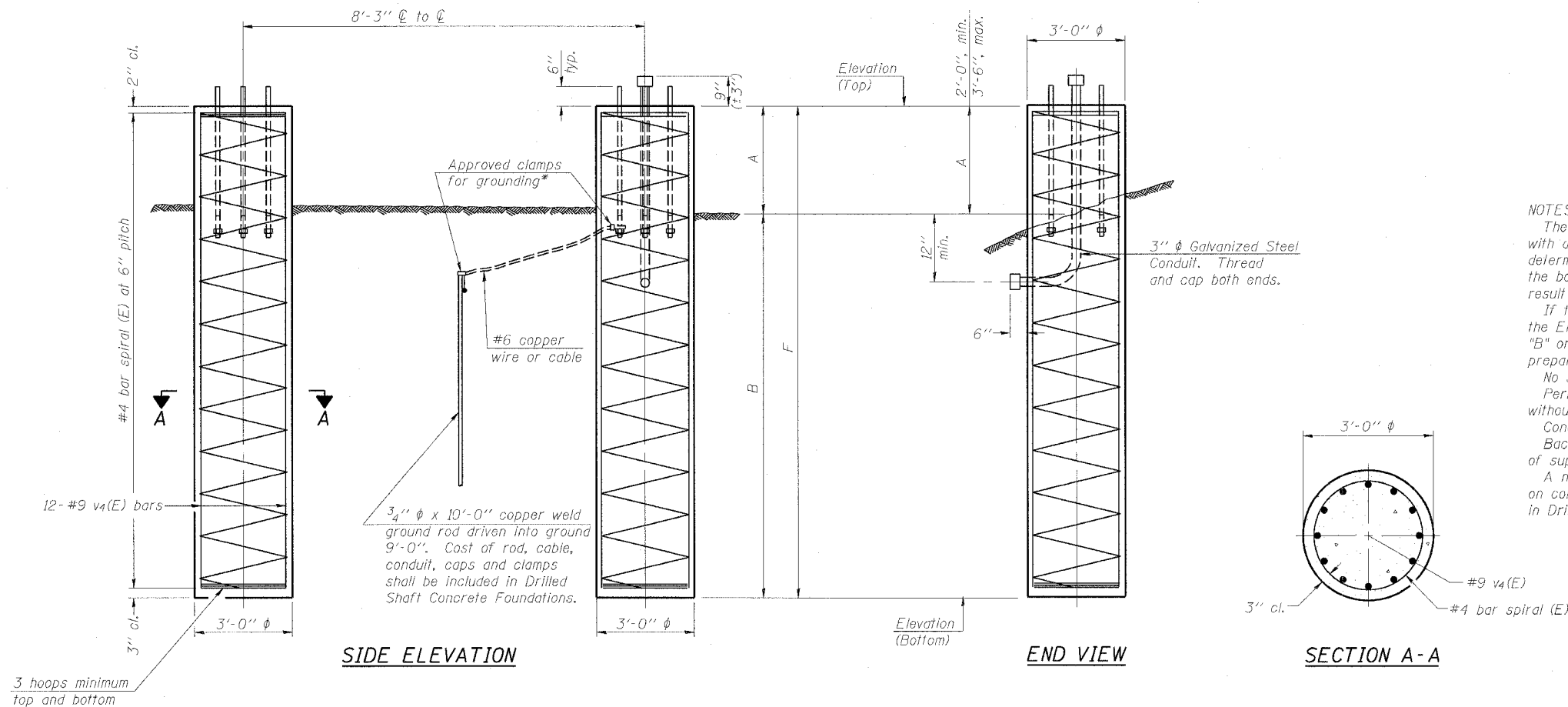

NOTES:

The foundation dimensions shown are based on the presence of mostly cohesive soils with an average Unconfined Compressive Strength (Q_u) of at least 1.25 tsf, which must be determined by previous soil investigations at the jobsite. When other conditions are indicated, the boring data will be included in the plans and the foundation dimensions shown will be the result of site specific designs.

If the conditions encountered are different than those indicated, the Contractor shall notify the Engineer to determine if the foundation dimensions need to be modified. If dimensions "B" or "F" are revised by more than 12" by the Contractor, "as-built" plans shall be prepared and submitted to the District Bureau of Operations for future reference.

No sonotubes or decomposable forms shall be used below the lower conduit entrance. Permanent metal forms or other shielding may not be left in place below that elevation without the Engineer's written permission.

Concrete shall be placed monolithically, without construction joints.

Backfill shall be placed per Article 502 of Standard Specification and prior to erection of support column.

A normal surface finish followed by a Bridge Seat Sealer application will be required on concrete surfaces above the lowest elevation 6" below finished ground line. Cost included in Drilled Shaft Concrete Foundation.

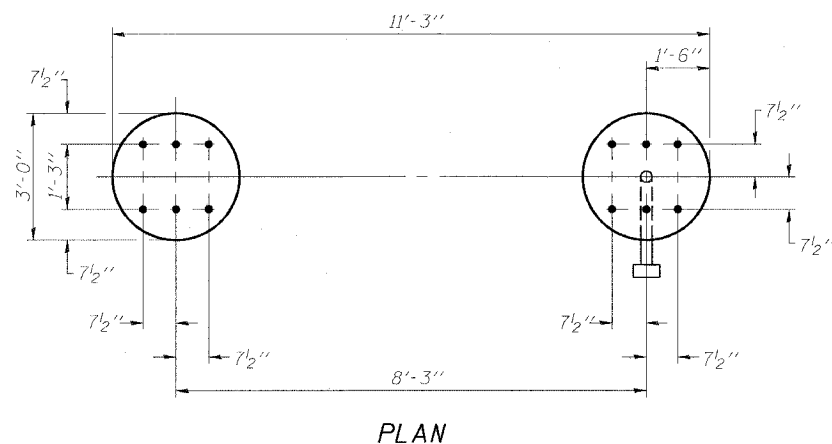

Structure Number	Station	Elevation Top	Elevation Bottom	Left Foundation			Right Foundation			Class SI Concrete (Cu. Yds.)		
				A	B	F	Elevation Top	Elevation Bottom	A		B	F
IS0161094L056.9	4518+40	---	---	---	---	---	12.30'	-7.20'	2.0'	17.5'	19.5'	10.2

DESIGNED	JSS
CHECKED	RDP
DRAWN	JSS
CHECKED	RDP

EXAMINED	20
PASSED	ENGINEER OF STRUCTURAL SERVICES
	ENGINEER OF BRIDGES AND STRUCTURES

NUMBER	REVISION	DATE

DETAILS FOR 10" Ø SUPPORT FRAME
TYPE I-A or II-A TRUSS

OVERHEAD SIGN STRUCTURES
DRILLED SHAFT DETAILS

F.A.I. 90/94 (DAN RYAN EXPRESSWAY)
GARFIELD BLVD TO 31ST STREET (NB LOCAL LANES)
PROPOSED IMPROVEMENT
GARFIELD BLVD TO 31ST STREET

OS4-F3 1-7-05

F:\P\4680\INR-C\18 & 19\3\F\Car\18SIGNING\SS180302.dgn 11-25-06 AM 6/7/2006

STATE OF ILLINOIS
DEPARTMENT OF TRANSPORTATION

ROUTE NO.	DIRECTION	COUNTY	TOTAL SHEETS	SHEET NO.	SHEET NO.
94/90	*	COOK	565	273	- SHEETS
FED. ROAD DIST. NO. 7	ILLINOIS	FED. AID PROJECT			

* 62301 (2021-922 PT2 ETC 2324.6-1P) R-10

For anchor rod size and placement, see Support Frame Detail Sheet.

* Anchor rod shall be ground or filed to bright metal at clamp and cable connection location.

BAR LIST - EACH FOUNDATION

Bar	Number	Size	Length	Shape
v4(E)	24	#9	F less 5"	—
#4 bar spiral (E) - see Side Elevation				

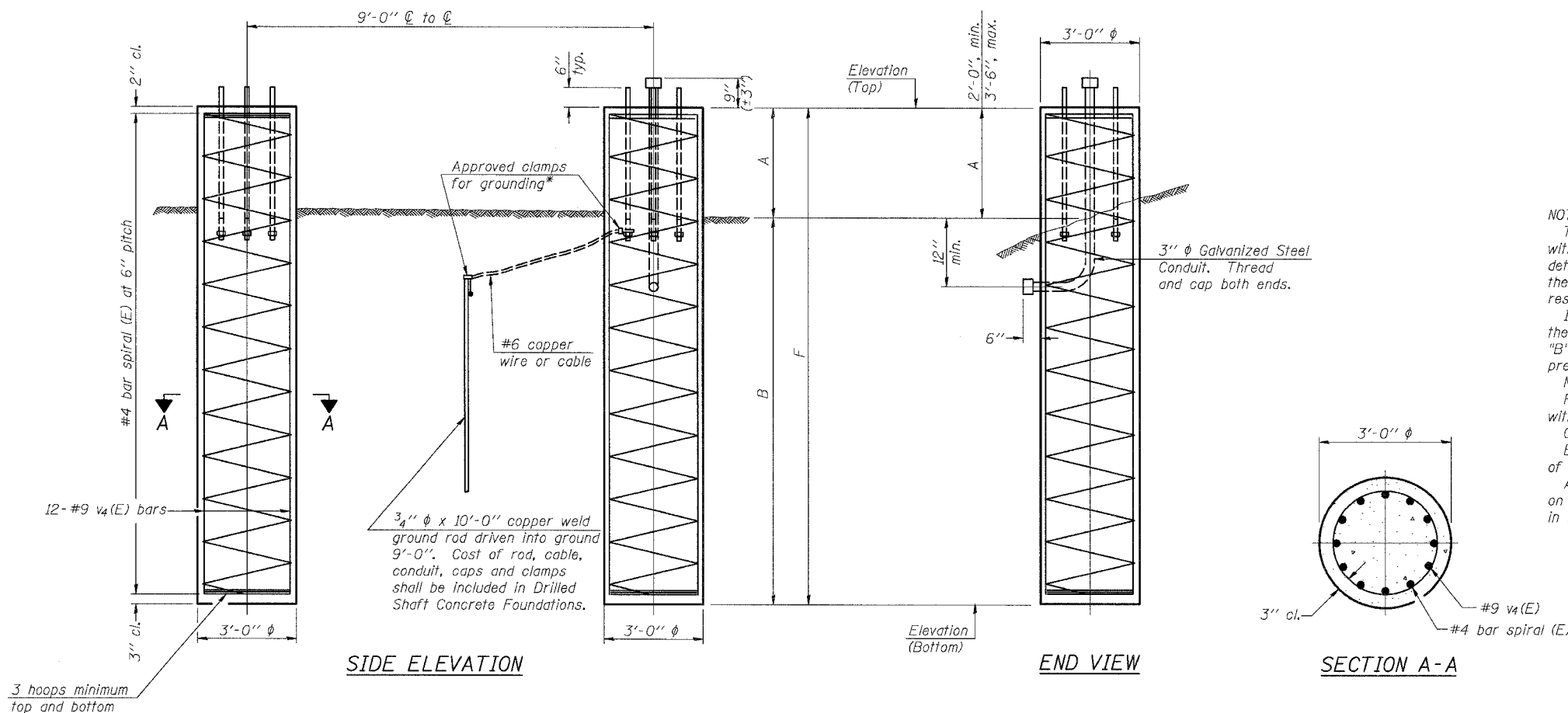

NOTES:

The foundation dimensions shown are based on the presence of mostly cohesive soils with an average Unconfined Compressive Strength (Qu) of at least 1.25 tsf, which must be determined by previous soil investigations at the jobsite. When other conditions are indicated, the boring data will be included in the plans and the foundation dimensions shown will be the result of site specific designs.

If the conditions encountered are different than those indicated, the Contractor shall notify the Engineer to determine if the foundation dimensions need to be modified. If dimensions "B" or "F" are revised by more than 12" by the Contractor, "as-built" plans shall be prepared and submitted to the District Bureau of Operations for future reference.

No sonotubes or decomposable forms shall be used below the lower conduit entrance.

Permanent metal forms or other shielding may not be left in place below that elevation without the Engineer's written permission.

Concrete shall be placed monolithically, without construction joints.

Backfill shall be placed per Article 502 of Standard Specification and prior to erection of support column.

A normal surface finish followed by a Bridge Seat Sealer application will be required on concrete surfaces above the lowest elevation 6" below finished ground line. Cost included in Drilled Shaft Concrete Foundation.

* Foundation built in Contract 62300

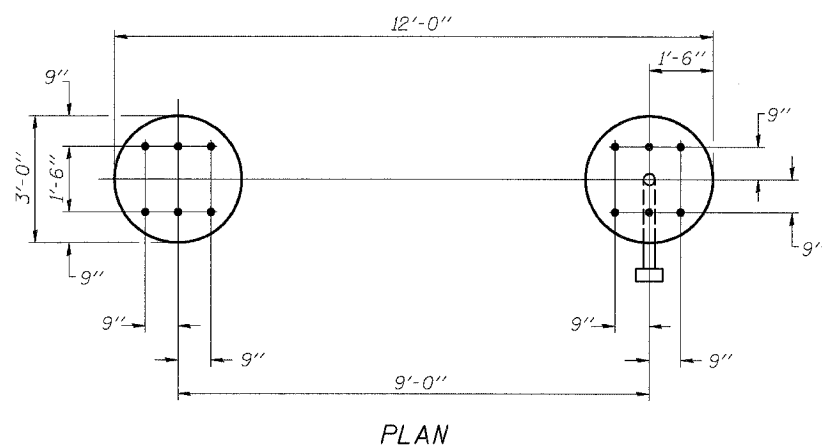

Structure Number	Station	Left Foundation *			Right Foundation			Class SI Concrete (Cu. Yds.)		
		Elevation Top	Elevation Bottom	F	Elevation Top	Elevation Bottom	F			
1S0161094L055.41	4599+00	-	-	-	14.50'	-6.00'	2.50'	18.00'	20.50'	10.70

SGN-31

DESIGNED	MSA
CHECKED	AS/ac
DRAWN	RV
CHECKED	MSA

EXAMINED	20
PASSED	

NUMBER	REVISION	DATE

DETAILS FOR 12" Ø SUPPORT FRAME
TYPE III-A TRUSS

OVERHEAD SIGN STRUCTURES
DRILLED SHAFT DETAILS

ILLINOIS DEPARTMENT OF TRANSPORTATION
F.A.I. 94/90 (DAN RYAN EXPRESSWAY)
GARFIELD BLVD TO 31ST STREET (NB LOCAL LANES)
OVERHEAD SIGN STRUCTURES
(SPAN)

OS4-F4

1-7-05

ns650/cadd/civil/IB sheets/ss160191a12.sht

STATE OF ILLINOIS
DEPARTMENT OF TRANSPORTATION

ROUTE NO.	SECTION	COUNTY	TOTAL SHEETS	SHEET NO.
F.A.I. RTE. 90/94	*	COOK	565	274
FED. ROAD DIST. NO. 1	ILLINOIS	FED. AID PROJECT		
* (181B, ETC. 2324.6-1P) R-10			62301	

* Anchor rod shall be ground or filed to bright metal at clamp and cable connection location.

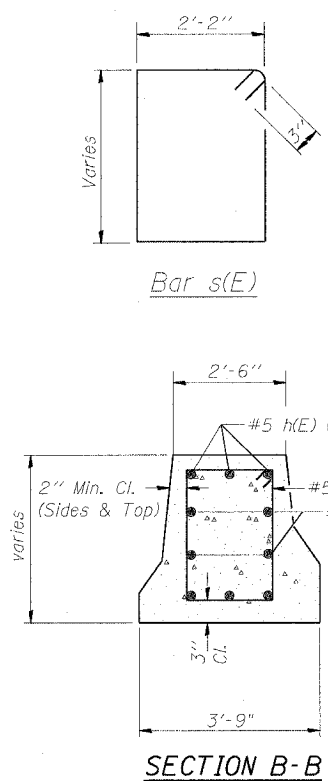
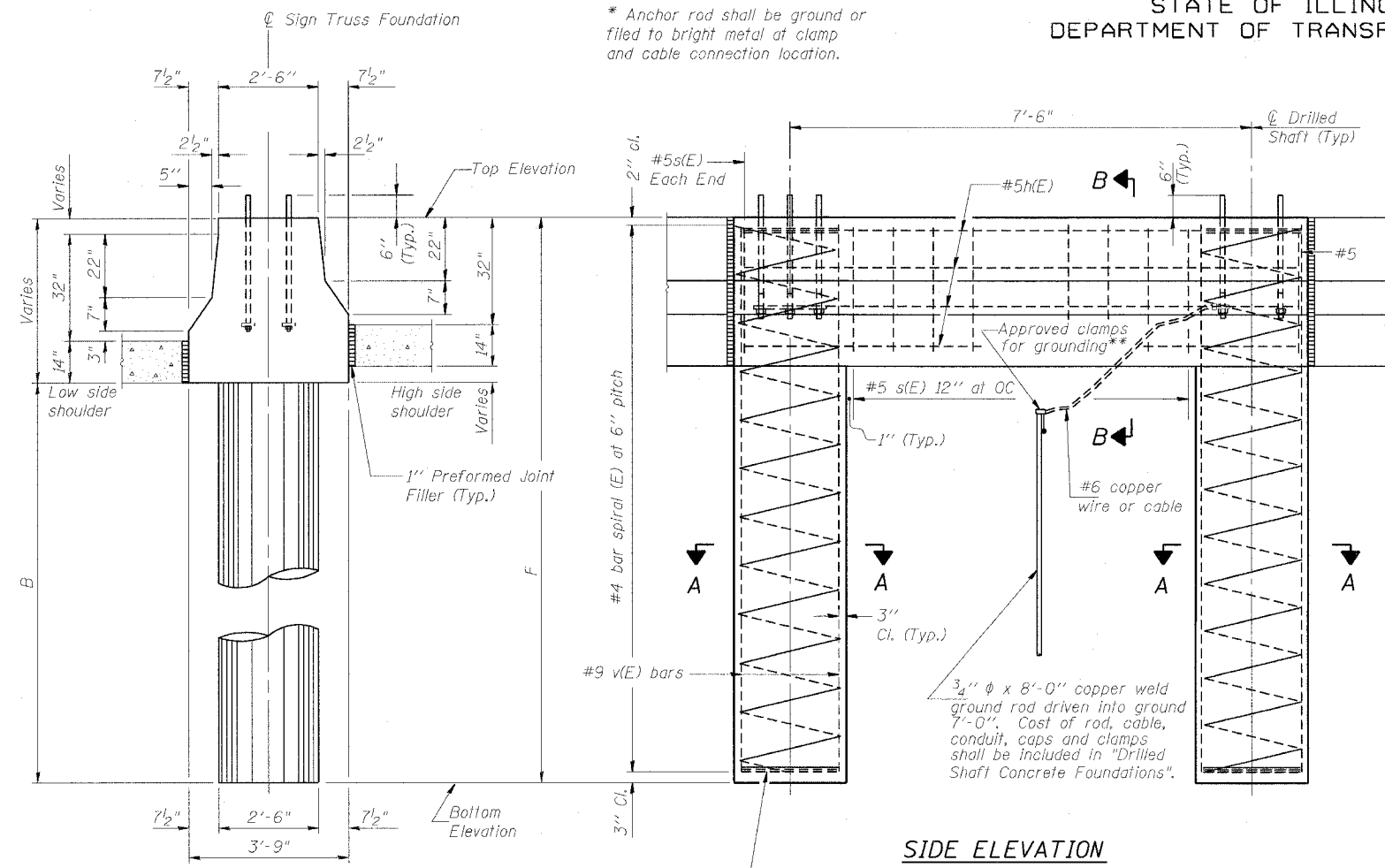

NOTES:
The foundation dimensions shown are based on the presence of mostly cohesive soils with an average Unconfined Compressive Strength (Q_u) of at least 1.25 tsf, which must be determined by previous soil investigations at the jobsite. When other conditions are indicated, the boring data will be included in the plans and the foundation dimensions shown will be the result of site specific designs.
If the conditions encountered are different than those indicated, the Contractor shall notify the Engineer to determine if the foundation dimensions need to be modified. If dimensions "B" or "F" are revised by more than 12" by the Contractor, "as-built" plans shall be prepared and submitted to the District Bureau of Operations for future reference.
No sonotubes or decomposable forms shall be used below the lower conduit entrance. Permanent metal forms or other shielding may not be left in place below that elevation without the Engineer's written permission.
Concrete shall be placed monolithically, without construction joints.
Backfill shall be placed per Article 502 of Standard Specification and prior to erection of support column.
A normal surface finish followed by a Bridge Seat Sealer application will be required on concrete surfaces above the lowest elevation 6" below finished ground line. Cost included in "Drilled Shaft Concrete Foundation".
Face of median support foundation shall match dimensions of permanent barrier wall F shape.

BAR LIST - EACH FOUNDATION

Bar	Number	Size	Length	Shape
h(E)	10	#5	9'-8"	—
s(E)	9	#5	Varies	□
v(E)	24	#9	F less 0'-5"	—

#4(E) bar spiral - see Side Elevation

SIDE ELEVATION
Concrete Foundation poured monolithically with no construction joint.
3 hoops minimum top and bottom (Typ.)

Structure Number	Station	Left Foundation				Right Foundation				Class SI Concrete (Cu. Yds.)
		Elevation Top	Elevation Bottom	B	F	Elevation Top	Elevation Bottom	B	F	
ISO161094L057.3	4498+00.00	5.25'	-12.53'	13.5'	17.78'	----	----	----	----	9.9
ISO161094L057.1	4506+75.00	3.12'	-14.74'	13.5'	17.86'	----	----	----	----	10.1

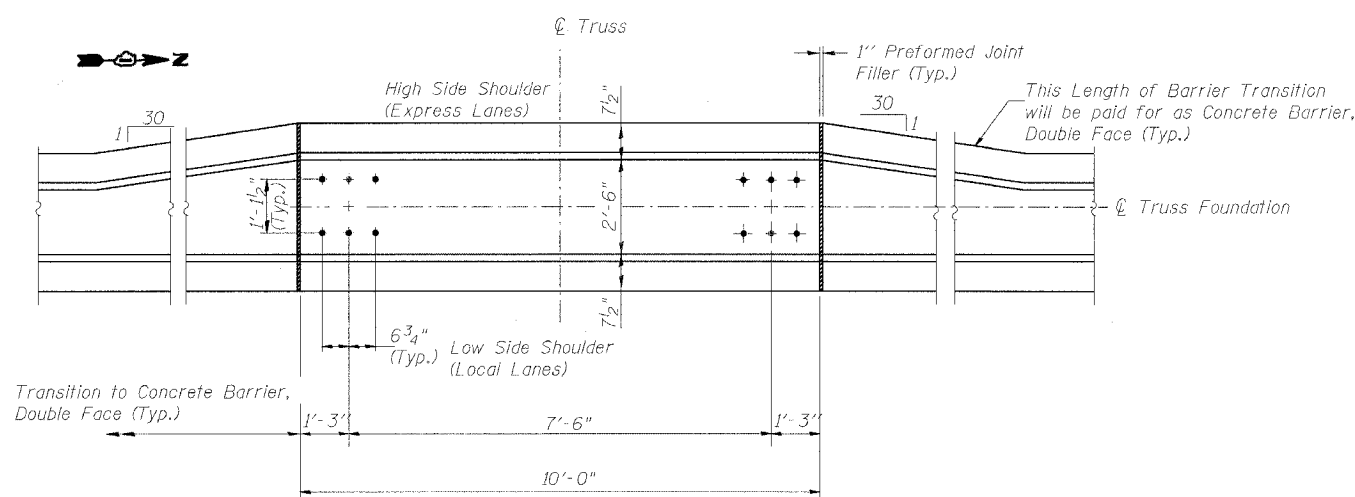

PLAN

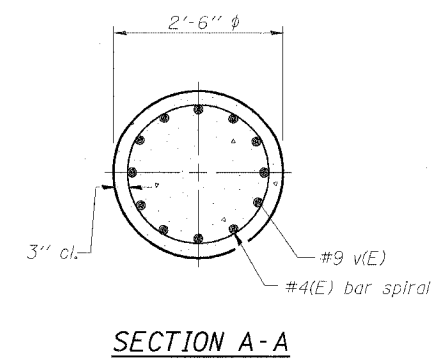

SECTION A-A

DESIGNED - JSS	20
CHECKED - RDP	EXAMINED
DRAWN - JSS	PASSED
CHECKED - RDP	ENGINEER OF STRUCTURAL SERVICES
	ENGINEER OF BRIDGES AND STRUCTURES

MODIFIED BY CTE ENGINEERS, INC. FROM OS4-MED

SGN-32

OVERHEAD SIGN STRUCTURES
MEDIAN SUPPORT FOUNDATION DETAILS

F.A.I. 90/94 (DAN RYAN EXPRESSWAY)
GARFIELD BLVD TO 31ST STREET (NB LOCAL LANES)
PROPOSED IMPROVEMENT
GARFIELD BLVD TO 31ST STREET
DOUBLE FACE MEDIAN SUPPORT FOUNDATION

P:\P\40468\CH\NB-Cntrs 1B & 1B\SN\Cntr 1B\Signing\SS180322A.dwg 6/7/2006 11:24:47 AM

STATE OF ILLINOIS
DEPARTMENT OF TRANSPORTATION

ROUTE NO.	SECTION	COUNTY	LIMIT SHEETS	SHEET NO.
F.A.I. RTE. 90/94	-	COOK	565	275
FED. ROAD DIST. NO. 1	ILLINOIS	FED. AID PROJECT-		
11818, ETC, 2324.6-1P1 R-10				62301

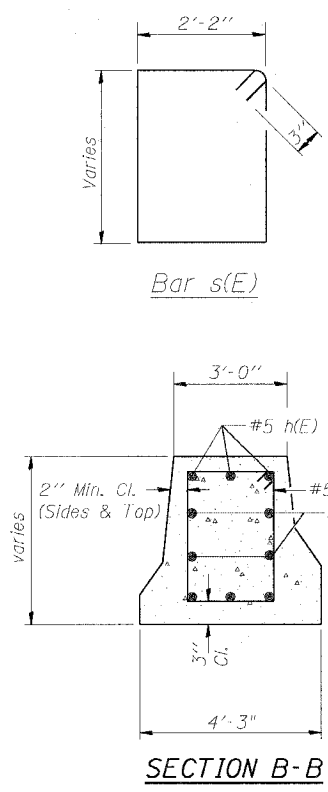
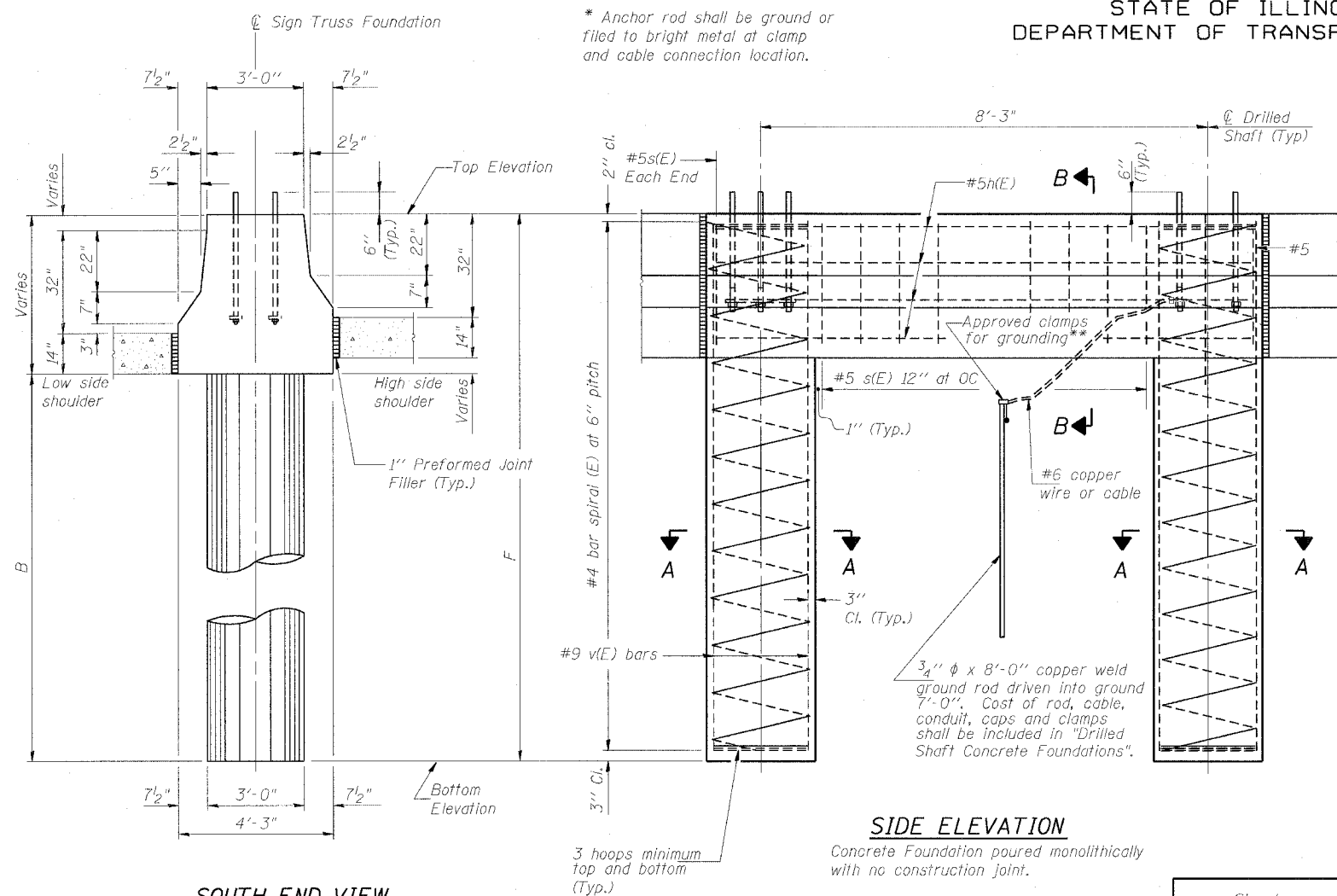

NOTES:

The foundation dimensions shown are based on the presence of mostly cohesive soils with an average Unconfined Compressive Strength (Qu) of at least 1.25 tsf, which must be determined by previous soil investigations at the jobsite. When other conditions are indicated, the boring data will be included in the plans and the foundation dimensions shown will be the result of site specific designs.

If the conditions encountered are different than those indicated, the Contractor shall notify the Engineer to determine if the foundation dimensions need to be modified. If dimensions "B" or "F" are revised by more than 12" by the Contractor, "as-built" plans shall be prepared and submitted to the District Bureau of Operations for future reference.

No sonotubes or decomposable forms shall be used below the lower conduit entrance. Permanent metal forms or other shielding may not be left in place below that elevation without the Engineer's written permission.

Concrete shall be placed monolithically, without construction joints.

Backfill shall be placed per Article 502 of Standard Specification and prior to erection of support column.

A normal surface finish followed by a Bridge Seat Sealer application will be required on concrete surfaces above the lowest elevation 6" below finished ground line. Cost included in "Drilled Shaft Concrete Foundations".

Face of median support foundation shall match dimensions of permanent barrier wall F shape.

BAR LIST - EACH FOUNDATION

Bar	Number	Size	Length	Shape
h(E)	10	#5	10'-11"	—
s(E)	8	#5	Varies	□
v(E)	24	#9	F less 0'-5"	—

#4(E) bar spiral - see Side Elevation

Structure Number	Station	Left Foundation				Right Foundation				Class SI Concrete (Cu. Yds.)
		Elevation Top	Elevation Bottom	B	F	Elevation Top	Elevation Bottom	B	F	
150161094L056.9	4518+40.00	11.27'	-10.97'	17.5'	22.24'	----	----	----	----	16.5

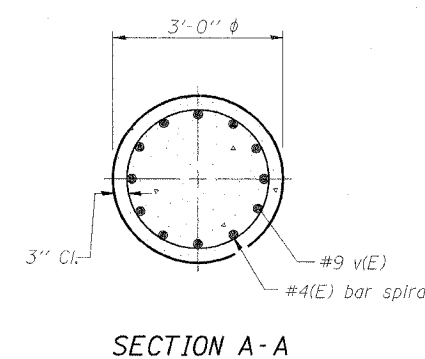
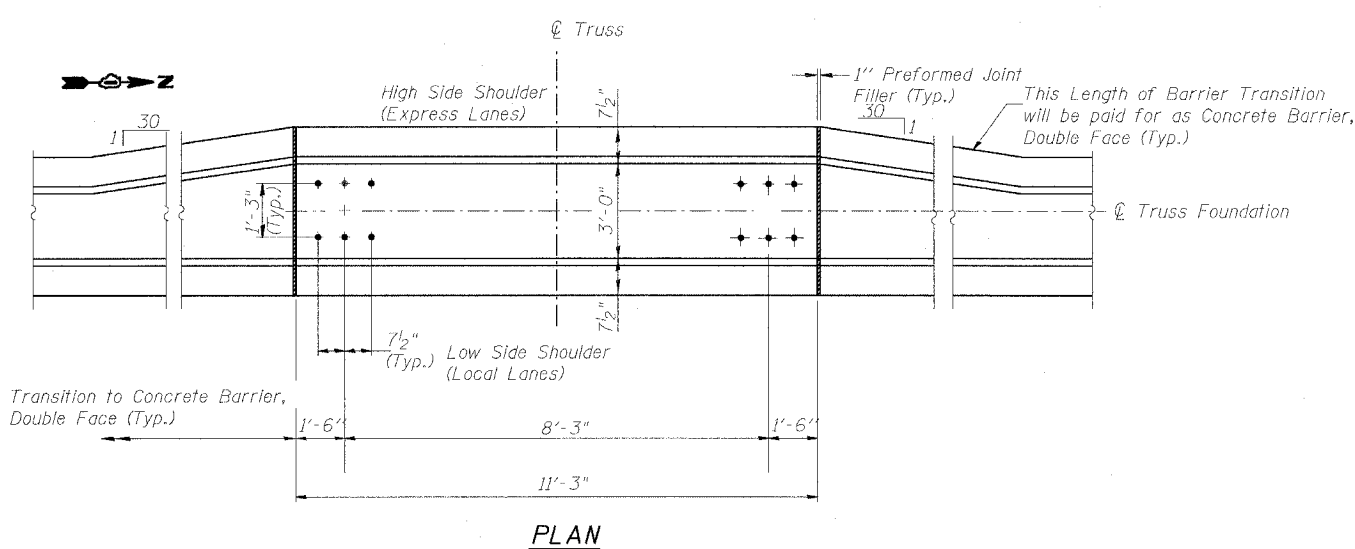

DESIGNED - JSS	20
CHECKED - RDP	EXAMINED
DRAWN - JSS	PASSED
CHECKED - RDP	ENGINEER OF STRUCTURAL SERVICES
	ENGINEER OF BRIDGES AND STRUCTURES

MODIFIED BY CTE ENGINEERS, INC. FROM OS4-MED

SGN-33

**OVERHEAD SIGN STRUCTURES
MEDIAN SUPPORT FOUNDATION DETAILS**

F.A.I. 90/94 (DAN RYAN EXPRESSWAY)
GARFIELD BLVD TO 31ST STREET (NB LOCAL LANES)
PROPOSED IMPROVEMENT
GARFIELD BLVD TO 31ST STREET
DOUBLE FACE MEDIAN SUPPORT FOUNDATION

6/7/2006 10:24:06 AM

STATE OF ILLINOIS
DEPARTMENT OF TRANSPORTATION

ROUTE NO.	SECTION	COUNTY	TOTAL SHEETS	SHEET NO.	SHEET NO. - - SHEETS
90/94	*	COOK	565	276	
FED. ROAD DIST. NO. 7		ILLINOIS	FED. AID PROJECT -		

* 62301 (2021-922 PT2 ETC 2324.6-1P) R-10

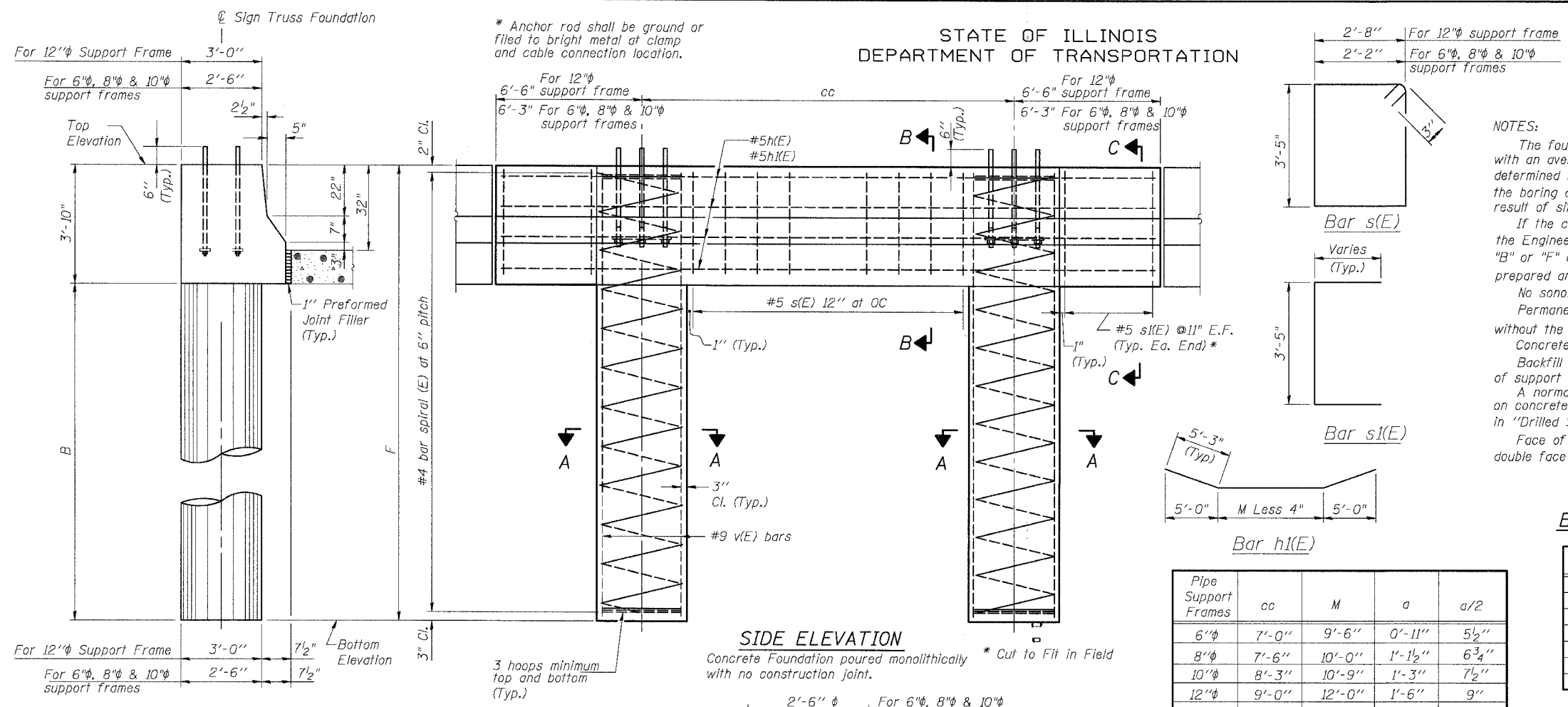

NOTES:

The foundation dimensions shown are based on the presence of mostly cohesive soils with an average Unconfined Compressive Strength (Qu) of at least 1.25 tsf, which must be determined by previous soil investigations at the jobsite. When other conditions are indicated, the boring data will be included in the plans and the foundation dimensions shown will be the result of site specific designs.

If the conditions encountered are different than those indicated, the Contractor shall notify the Engineer to determine if the foundation dimensions need to be modified. If dimensions "B" or "F" are revised by more than 12" by the Contractor, "as-built" plans shall be prepared and submitted to the District Bureau of Operations for future reference.

No sonotubes or decomposable forms shall be used below the lower conduit entrance. Permanent metal forms or other shielding may not be left in place below that elevation without the Engineer's written permission.

Concrete shall be placed monolithically, without construction joints.

Backfill shall be placed per Article 502 of Standard Specification and prior to erection of support column.

A normal surface finish followed by a Bridge Seat Sealer application will be required on concrete surfaces above the lowest elevation 6" below finished ground line. Cost included in "Drilled Shaft Concrete Foundation".

Face of median support foundation shall match dimensions of permanent concrete barrier, double face (32" height)

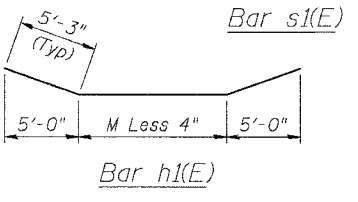

Pipe Support Frames	cc	M	a	a/2
6"φ	7'-0"	9'-6"	0'-11"	5 1/2"
8"φ	7'-6"	10'-0"	1'-1 1/2"	6 3/4"
10"φ	8'-3"	10'-9"	1'-3"	7 1/2"
12"φ	9'-0"	12'-0"	1'-6"	9"

BAR LIST - EACH FOUNDATION

Bar	Number	Size	Length	Shape
h(E)	6	#5	L less 0'-4"	—
h(E)	4	#5	M less 4"+10'-6"	—
s(E)	Varies	#5	13'-8" or 12'-8"	□
s(E)	24	#5	Varies	□
v(E)	24	#9	F less 0'-5"	—
v(E)	16	#19	F less 0'-5"	—

#4(E) bar spiral - see Side Elevation

END VIEW D-D

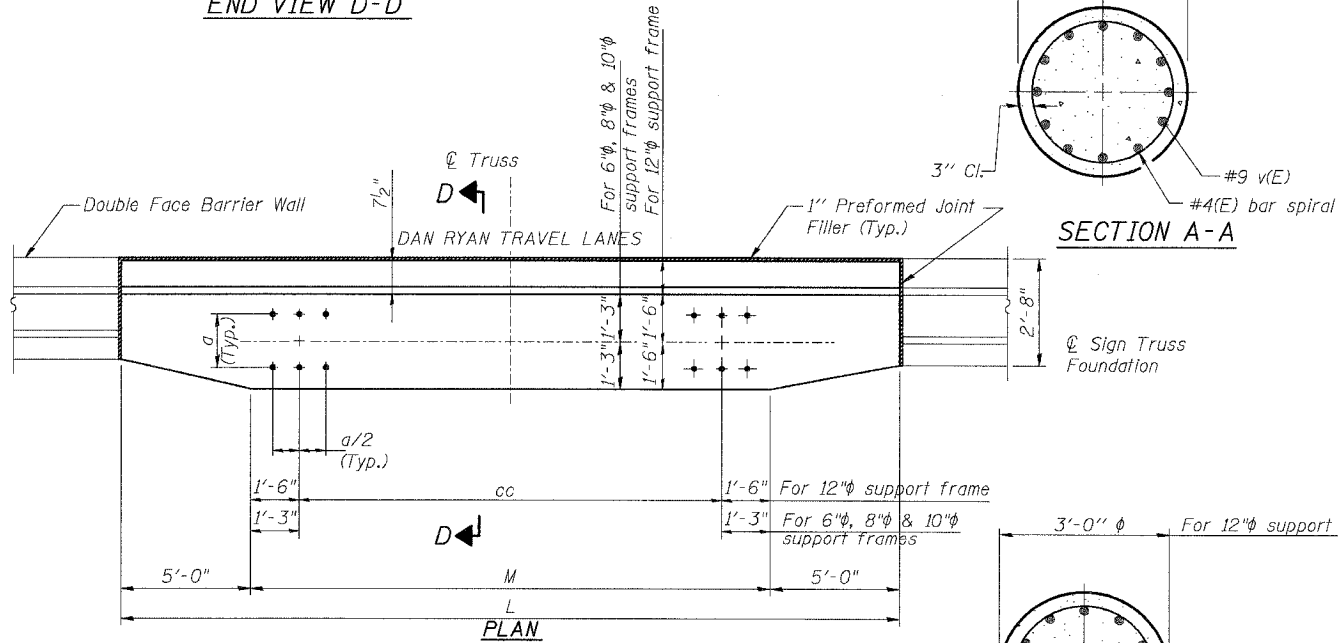

LEFT FOUNDATION FROM CONTRACT 62300 TO BE USED

Pipe Support Frame	Structure Number	Station	Left Foundation				Right Foundation				Class SI Concrete (Cu. Yds.)
			Elevation Top	Elevation Bottom	B	F	Elevation Top	Elevation Bottom	B	F	
10"	ISO161094L056.60	4535+80	-	-	-	-	9.31	-11.02	16.5'	20.33'	14.5

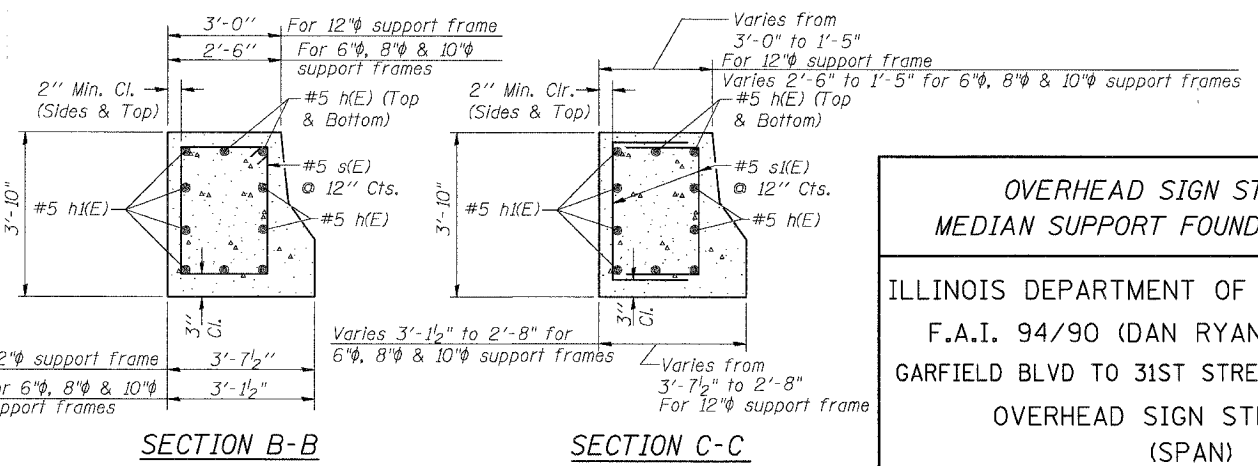

DESIGNED - KEI	EXAMINED -	20
CHECKED -	PASSED -	ENGINEER OF STRUCTURAL SERVICES
DRAWN -	PASSED -	ENGINEER OF BRIDGES AND STRUCTURES
CHECKED -		

MODIFIED FROM OS4-MED

SGN-34

OVERHEAD SIGN STRUCTURES
MEDIAN SUPPORT FOUNDATION DETAILS

ILLINOIS DEPARTMENT OF TRANSPORTATION
F.A.I. 94/90 (DAN RYAN EXPRESSWAY)
GARFIELD BLVD TO 31ST STREET (NB LOCAL LANES)
OVERHEAD SIGN STRUCTURES
(SPAN)

6/7/2006 1:50:36 PM

STATE OF ILLINOIS
DEPARTMENT OF TRANSPORTATION

ROUTE NO.	SECTION	COUNTY	TOTAL SHEETS	SHEET NO.
94/90	*	COOK	565	277
FED. ROAD DIST. NO. 7	ILLINOIS	FED. ROAD PROJECT		

* 62301 (2021-922 PT2 ETC 2324.6-1P) R-10

GENERAL NOTES

SPECIFICATIONS:
DESIGN: AASHTO Standard Specifications for Structural Supports for Highway Signs, Luminaires and Traffic Signals. ("AASHTO Specifications") (2)
CONSTRUCTION: Current (at time of letting) Illinois Department of Transportation Standard Specifications for Road and Bridge Construction, Supplemental Specifications and Special Provisions. ("Standard Specifications")
LOADING: 80 M.P.H. WIND VELOCITY PLUS 30% GUST FACTOR
WIND LOADING: 35 p.s.f. normal to Sign Panel Area and truss elements not behind sign Loading Diagram.
WALKWAY LOADING: Dead load plus 500 lbs. concentrated live load.
MINIMUM CLEARANCE: 3" greater than bridge members at all locations. (All Obstructions)
WELDING: All welds to be continuous unless otherwise shown. All welding to be done in accordance with current AWS D1.1 Structural Welding Code (Steel) and the Standard Specifications.
MATERIALS: All Structural Steel Pipe shall be ASTM A53 Grade B with a minimum yield of 35,000 p.s.i., or A500 Grade B or C with a minimum yield of 46,000 p.s.i. If A500 pipe is substituted for A53, then the outside diameter shall be as detailed and wall thickness greater than or equal to A53.
 All Structural Steel Plates and Shapes shall conform to AASHTO M270 Gr. 36, Gr. 50 (M183, M223 Gr. 50).
HIGH STRENGTH BOLTS: All bolts, washers, nuts and locknuts shall satisfy the requirements of ASTM designation A307 unless noted as "H.S." which shall require AASHTO M164 (A325), ASTM A449, or approved alternate. All fasteners shall be hot dip galvanized per AASHTO M232 unless otherwise specified.
GALVANIZING: All Steel Grating, Plates, Shapes and Pipe shall be Hot Dip Galvanized after fabrication in accordance with AASHTO M111. Painting is not permitted.
ANCHOR RODS: All threaded rod conforming to ASTM A307, 3/4" ϕ x 12" long, each with one plate washer and locknut and be hot dip galvanized per AASHTO M232. They shall be either cast into the concrete or epoxy grouted in accordance with Section 584 of the Standard Specifications. Minimum embedment in concrete shall be 9".

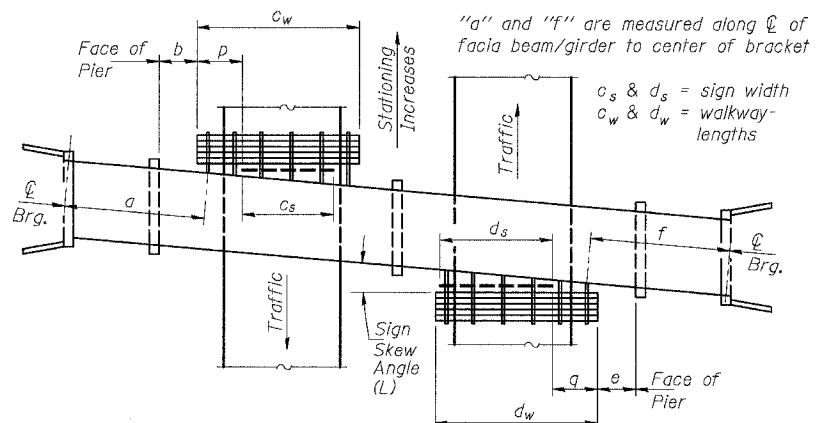

PLAN
(Left Sign Skew > 15°)
WALKWAY AND HANDRAIL SKETCH
(Road plan beneath structure varies.)

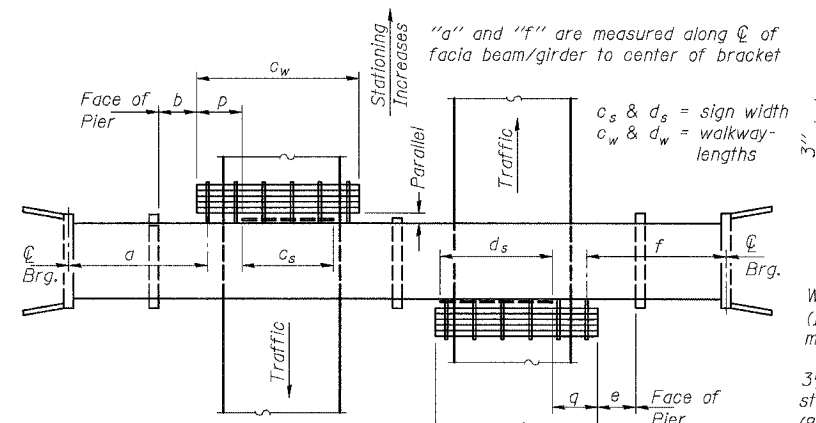

PLAN
(For Sign Skew $\leq 15^\circ$, all brackets constant)
WALKWAY AND HANDRAIL SKETCH
(Road plan beneath structure varies.)

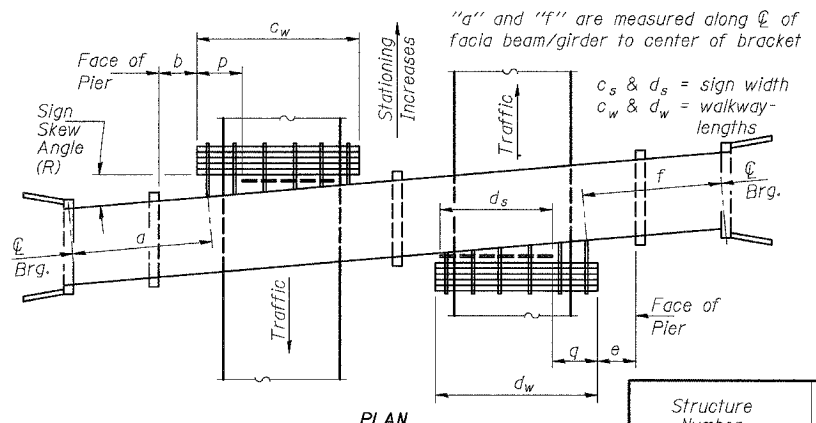

PLAN
(Right Sign Skew > 15°)
WALKWAY AND HANDRAIL SKETCH
(Road plan beneath structure varies.)

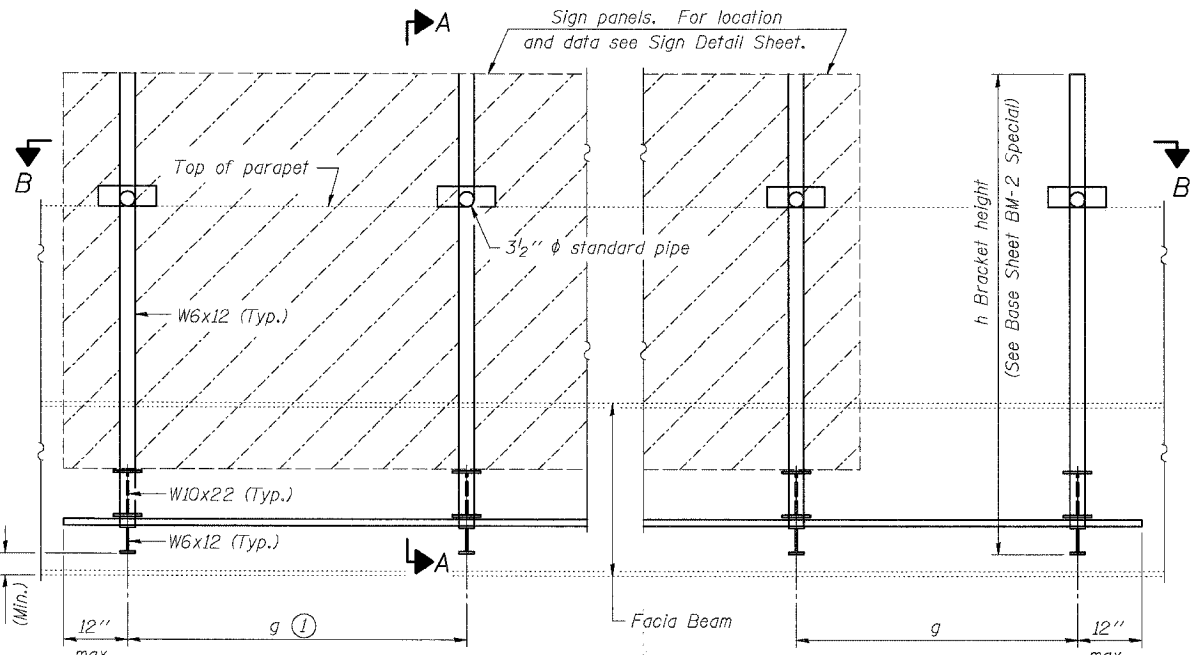

TYPICAL FRONT ELEVATION
(With lights, safety chain and handrail omitted for clarity.)

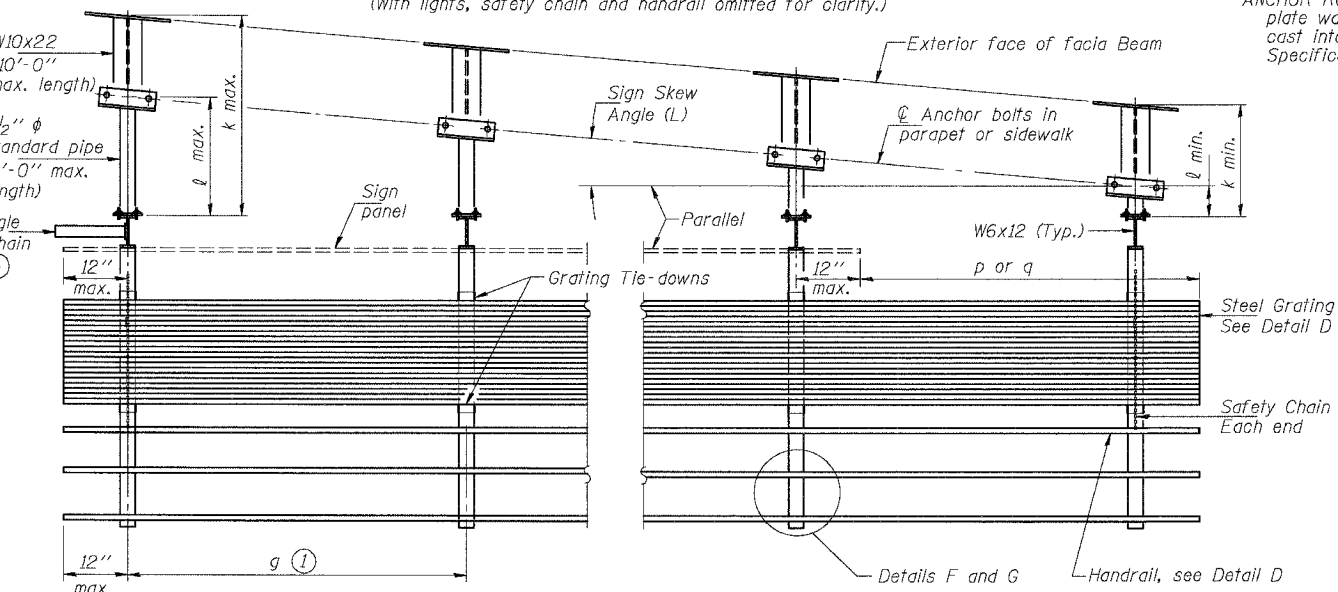

SECTION B-B
(Shown: Left Sign Skew > 15°)

- Bracket spacing $g \leq 6'-0"$ max. Spacing shall be uniform if possible but may vary $\pm 6"$ to miss existing obstruction (rail post, light poles, web stiffeners, splice plates, etc.). Adjust bracket lengths accordingly on skewed structures.
- Any design modifications shall be based on the current version of applicable specifications and submitted for the Engineer's approval.
- Unit price includes grating, handrail, brackets, supports, anchor bolts, fasteners, fabrication, delivery, erection, field drilling and other necessary items. Limits of payment are based on grating length (c_w , d_w) unless otherwise specified.
- For Safety Chain Details and Details D, F and G, see Base Sheet BM-4 Special.
- If walkway bracket at safety chain location is behind sign, add angle to bracket. See detail on Base Sheet BM-4 Special.

NUMBER	REVISION	DATE

TOTAL BILL of MATERIAL

SGN-35

OVERHEAD SIGN STRUCTURE - BRIDGE MOUNTED	Foot	161.50
--	------	--------

Structure Number	Sign Skew Angle (L) or (R)	Bridge Station	Bridge Structure Number	Contract Route Designation	a	b	c _s	c _w	d _s	d _w	e	f	g	No. of Brackets (Total)	p	q	Total Grating/Hndrl. Lengths (c _w + d _w)
1B0161094L055.73	0	4582+26±	016-0398	I-94	-	-	-	-	17.5'/23'/10.5'	52.0'	-	6.625'	4'/5.5'/4.5'	13	-	0	52.0'
1B0161094L054.97	0	4622+31±	016-1158	I-94	-	-	-	-	17.5'/23'/9'	54.5'	9.09'	45.84'	4'/5.5'/4'	14	-	4.0'	54.5'
1B0161094L054.72	0	4635+47±	016-1159	I-94	-	-	-	-	17.5'/23'	55.00'	11.66'	46.54'	4'/5.5'	13	-	4.66'	55.00'

Dimensions a, b, e, f & g may vary as approved by the Engineer, see (1).
When $c_w < c_s$ and/or $d_w < d_s$, use alternate brackets without walkway supports where applicable, see (3).

DESIGNED	MSA	20
CHECKED	AS/AC	EXAMINED
DRAWN	RV	PASSED
CHECKED	MSA	ENGINEER OF BRIDGES AND STRUCTURES

BRIDGE MOUNT SIGN STRUCTURES
GENERAL PLAN AND ELEVATION
ILLINOIS DEPARTMENT OF TRANSPORTATION
F.A.I. 94/90 (DAN RYAN EXPRESSWAY)
GARFIELD BLVD TO 31ST STREET (NB LOCAL LANES)
OVERHEAD SIGN STRUCTURES
(BRIDGE MOUNTED)

STATE OF ILLINOIS
DEPARTMENT OF TRANSPORTATION

ROUTE NO.	SECTION	COUNTY	TOTAL SHEETS	SHEET NO.
94/90		COOK	565	278
FED. ROAD DIST. NO. 7	ILLINOIS	FED. AID PROJECT-		

• 62301 (2021-922 PT2 ETC 2324.6-1P) R-10

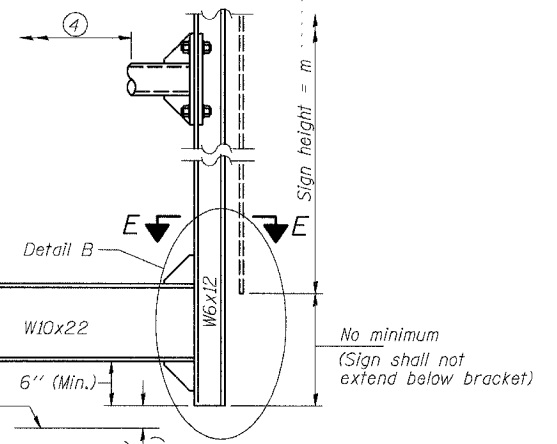
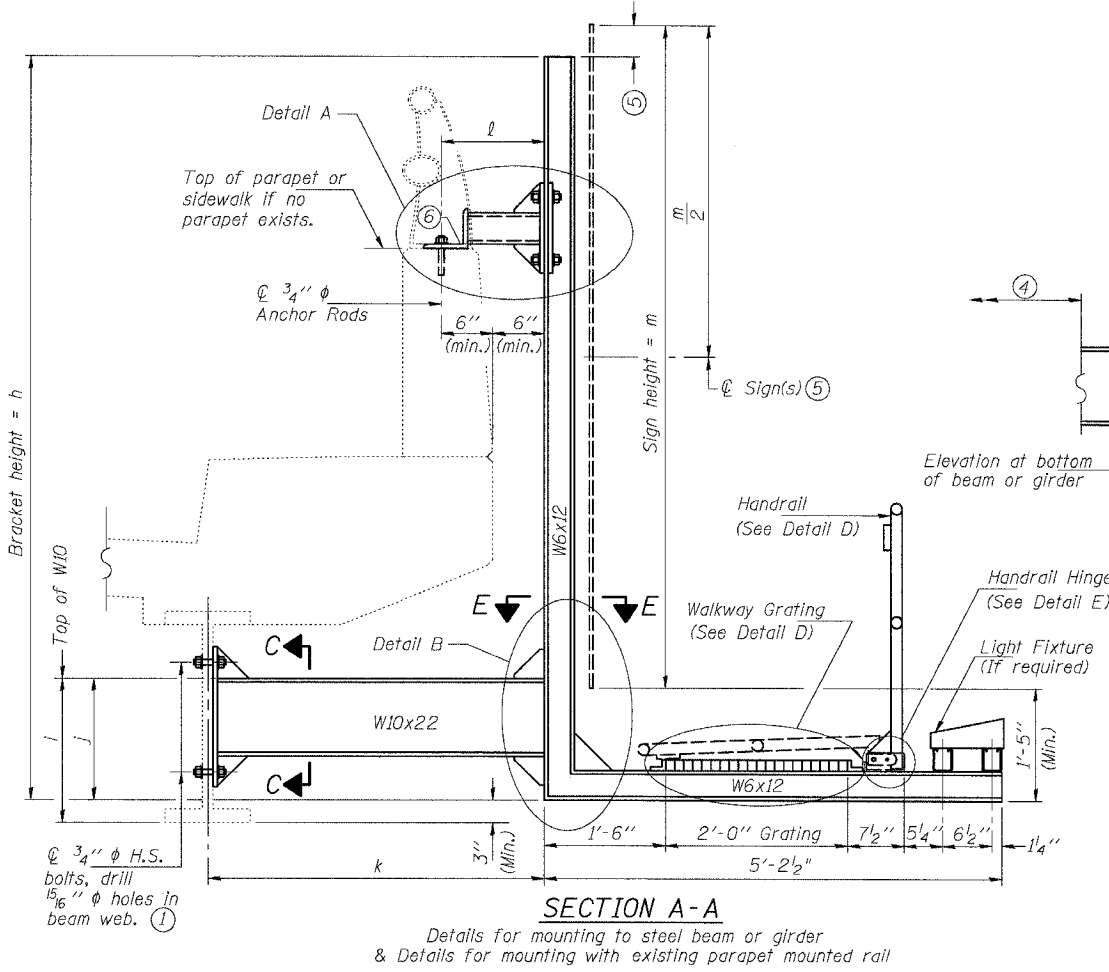

SECTION A-A
Alternate with no lights or walkways
④ For attachment details of 3/2" pipe and W10x22, see other sections as applicable.

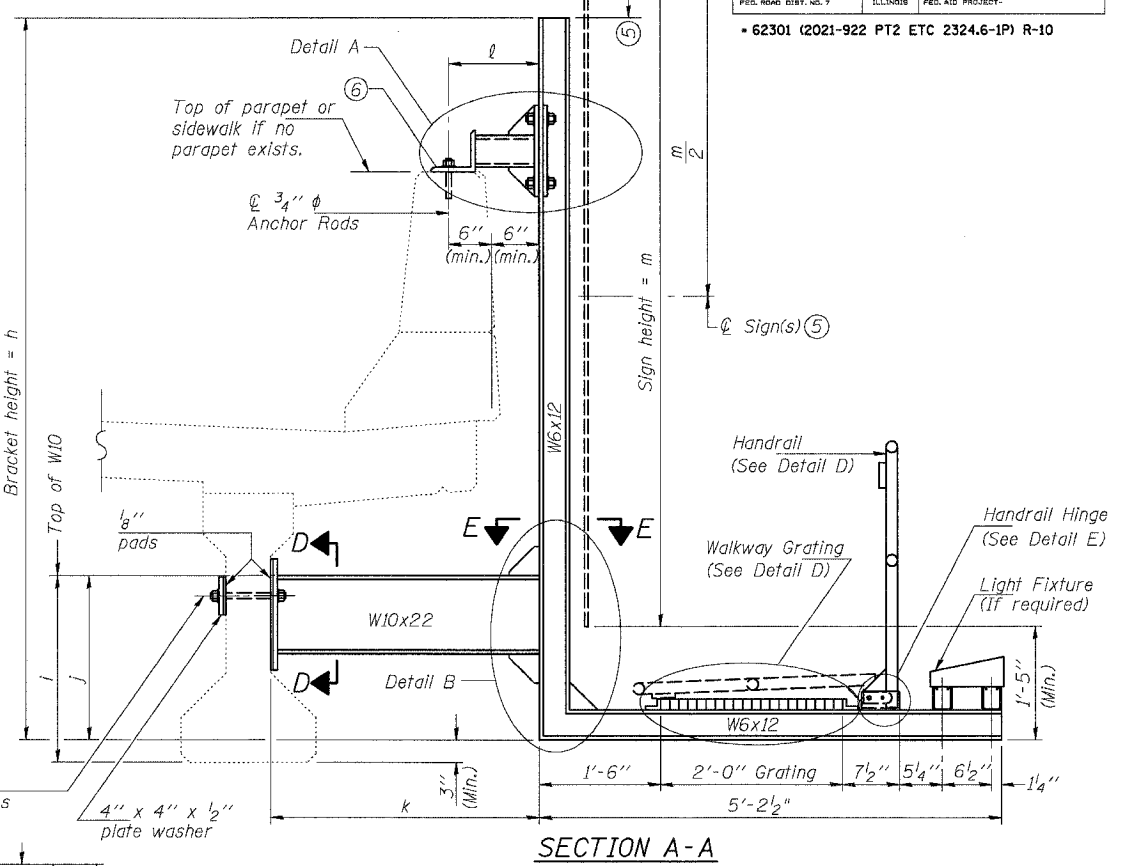

SECTION A-A
Details for mounting to PPC I Beam or Bulb "T"
& Details for mounting to parapet w/o rail
NOTES:
Installations not within dimensional limits shown require special analysis for all components and must be submitted to the Bureau of Bridges and Structures for approval.
Contractor shall field check all pertinent existing bridge dimensions shown on plans before submitting shop drawings.
All holes in bridge beams or girders should be located in the middle half of the member. There shall be no holes drilled in the lower quarter of the member's depth. (For R.C. girder, depth = bottom of deck to bottom of the girder.) Proposed exceptions must be approved by the Bureau of Bridges and Structures.
The Engineer may adjust dimension "i" to meet the above condition and to keep the sign level.

Structure Number	Station	h	i	j	k max. (10'-0" max.)	l max. (8'-0" max.)	m (15'-0" max.)
IB0161094L055.73	4582+26±	14.92'	1.66'	1.41'	3.64'	1.13'	14'/7'
IB0161094L054.97	4622+31±	14.92'	1.67'	1.42'	3.50'	1.09'	14'/8'
IB0161094L054.72	4635+47±	14.92'	1.81'	1.56'	3.50'	1.09'	14'

For Details A & B, Sections C-C, D-D and E-E, see Base Sheet BM-3 Special.
For Details D & E, see Base Sheet BM-4 Special.

- ① Holes in new steel members may be drilled in the fabrication shop or in the field. Field drill existing members.
- ② For new PPC I beams, holes shall be formed during casting. For existing PPC I beams, prestressing strand locations shall be determined and spaced to miss strands by 6" min. Minimize spalling during field drilling of existing beams.
- ③ For new construction, form holes. For existing RC beams, locate primary reinforcement and space holes to miss by 6" min. Minimize spalling and concrete fracturing/damage during field drilling of existing beams. Spalls over 1/4" deep or beyond the coverage of the 4x4 plate washer shall be repaired with epoxy mortar before installing washer.

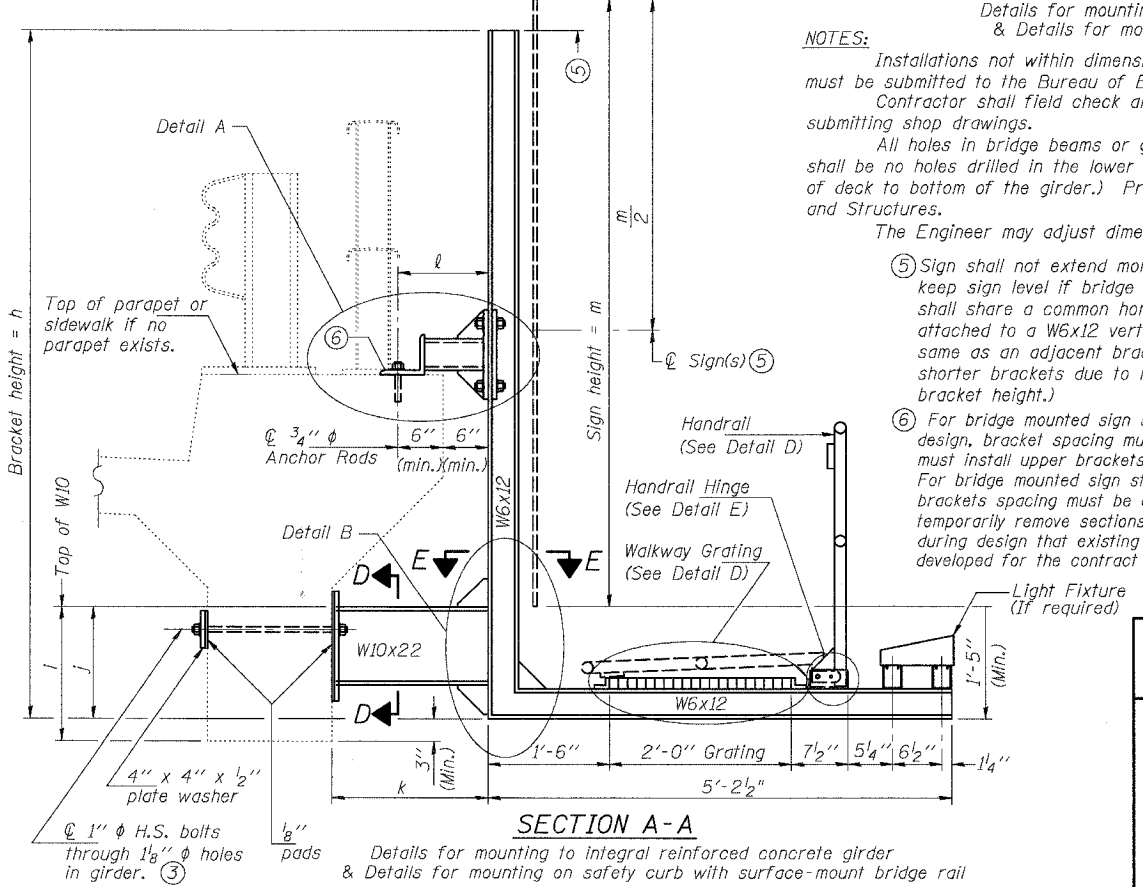

- ⑤ Sign shall not extend more than 6" above top of bracket, and this dimension may vary to keep sign level if bridge is on grade or vertical curve. Multiple signs of various heights shall share a common horizontal centerline and use equal bracket heights. If no sign is attached to a W6x12 vertical (bracket only supporting walkway), dimension h shall be the same as an adjacent bracket with a sign attached, unless Engineer specifically directs shorter brackets due to locational restraints on future uses. (See Detail A for minimum bracket height.)
- ⑥ For bridge mounted sign structures installed on new bridges with railing, during design, bracket spacing must be coordinated with railing post spacing and the Contractor must install upper brackets prior to railing installation. For bridge mounted sign structures installed on existing bridges with railing, during design, brackets spacing must be coordinated with railing post spacing and the Contractor must temporarily remove sections of railing to facilitate upper bracket installation. If it is determined during design that existing railings can't be removed, alternate upper connection details must be developed for the contract plans and approved by the Bureau of Bridges and Structures.

DESIGNED	MSA	20
CHECKED	AS/AC	EXAMINED
DRAWN	RV	PASSED
CHECKED	MSA	ENGINEER OF BRIDGES AND STRUCTURES

NUMBER	REVISION	DATE

BM-2 Special 1/7/05

**BRIDGE MOUNT SIGN STRUCTURES
WALKWAY AND CONNECTION DETAILS**
ILLINOIS DEPARTMENT OF TRANSPORTATION
F.A.I. 94/90 (DAN RYAN EXPRESSWAY)
GARFIELD BLVD TO 31ST STREET (NB LOCAL LANES)
OVERHEAD SIGN STRUCTURES
(BRIDGE MOUNTED)

SGN-36

STATE OF ILLINOIS
DEPARTMENT OF TRANSPORTATION

ROUTE NO.	SECTION	COUNTY	TOTAL SHEETS	SHEET NO.	SHEET NO.
94/90		COOK	565	279	- SHEETS
FED. ROAD DIST. NO. 7		ILLINOIS		FED. AID PROJECT-	

*62301 (2021-922 PT2 ETC 2324.6-1P) R-10

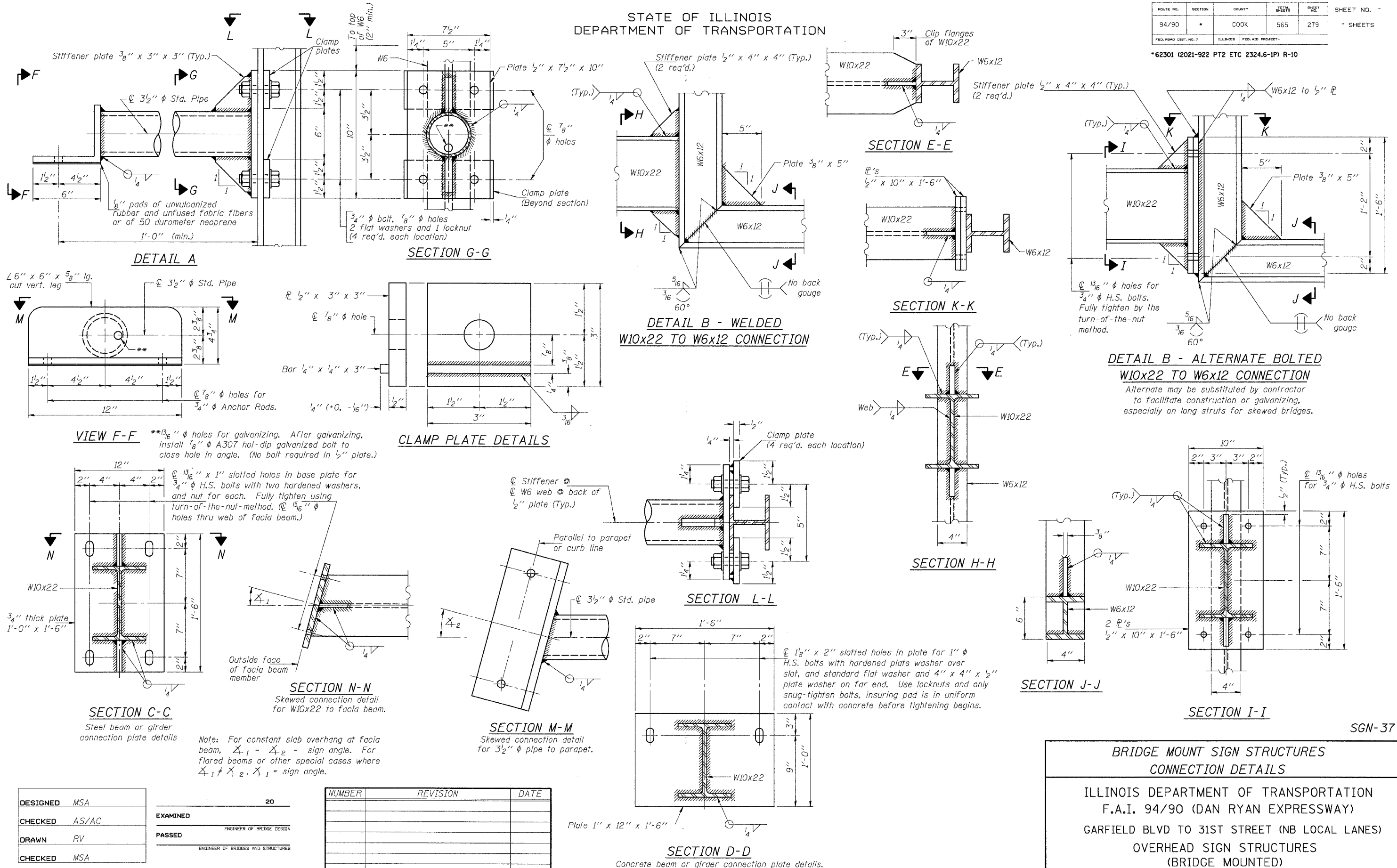

DESIGNED	MSA
CHECKED	AS/AC
DRAWN	RV
CHECKED	MSA

EXAMINED	20
PASSED	ENGINEER OF BRIDGE DESIGN
	ENGINEER OF BRIDGES AND STRUCTURES

NUMBER	REVISION	DATE

BM-3 Special 1/7/05

BRIDGE MOUNT SIGN STRUCTURES
CONNECTION DETAILS
ILLINOIS DEPARTMENT OF TRANSPORTATION
F.A.I. 94/90 (DAN RYAN EXPRESSWAY)
GARFIELD BLVD TO 31ST STREET (NB LOCAL LANES)
OVERHEAD SIGN STRUCTURES
(BRIDGE MOUNTED)

SGN-37

STATE OF ILLINOIS
DEPARTMENT OF TRANSPORTATION

ROUTE NO.	SECTION	COUNTY	SHEETS	SHEET NO.
94/90		COOK	565	280
FED. ROAD DIST. NO. 7	ILLINOIS	FED. AID PROJECT-		

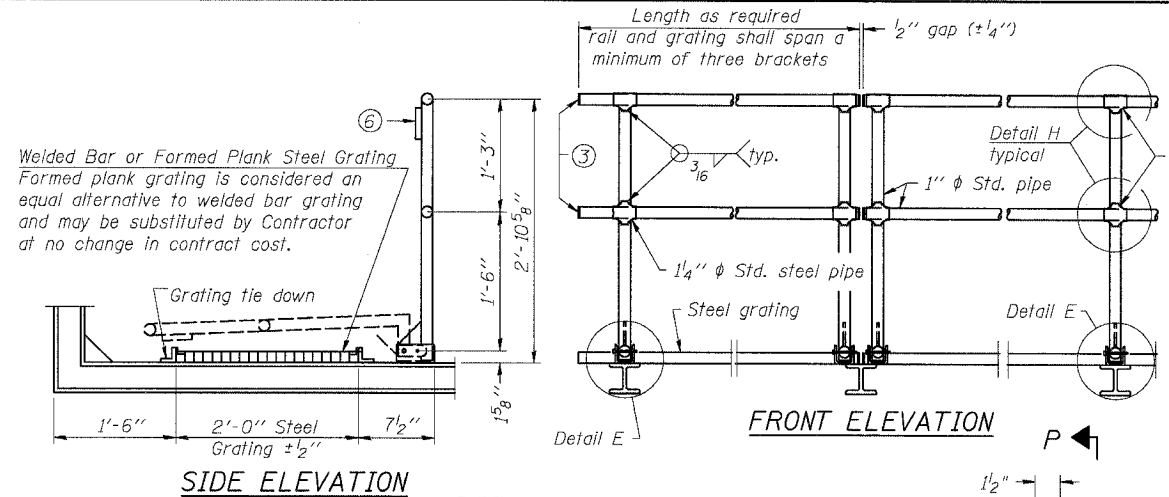

SIDE ELEVATION

FRONT ELEVATION

DETAIL D HANDRAIL

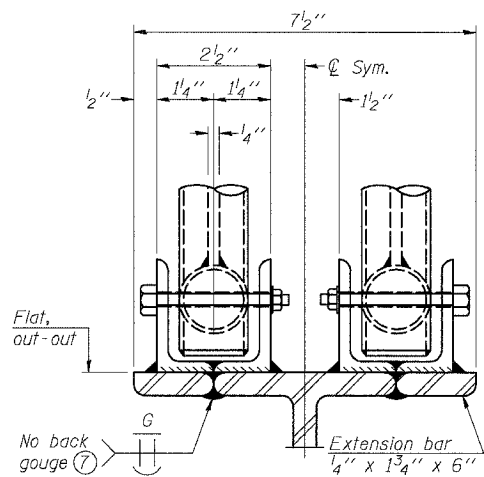

ELEVATION AT HANDRAIL JOINT

(Details not shown same as "FRONT ELEVATION")

L 2 1/2" x 1 1/4" x 1/4", 5" long

3/16" hole for 3/8" bolt with washer and hexagon locknut

SIDE ELEVATION

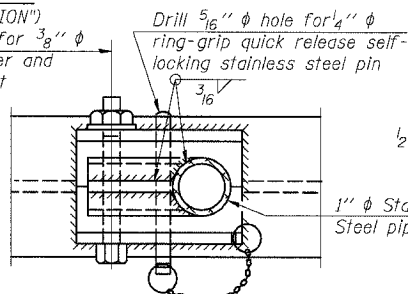

PLAN AT SINGLE HANDRAIL HINGE

DETAIL E

SAFETY CHAIN ATTACHMENT

(With Sign Present)
Items not shown same as "SIDE ELEVATION" and "SAFETY CHAIN"

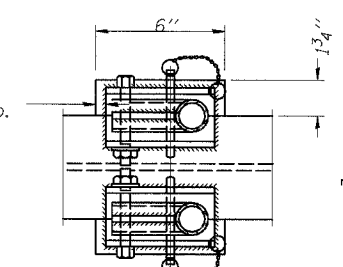

PLAN AT HANDRAIL JOINT

(For Details, see Elevations.)

SECTION P-P

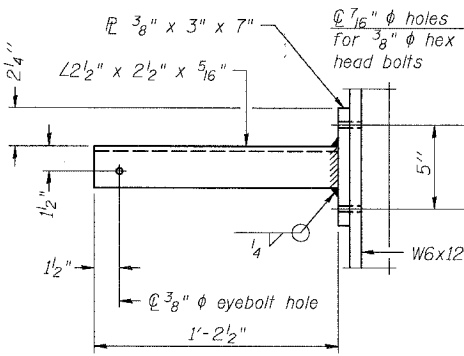

GRATING CONTINUOUS AT GRATING SPLICE

VIEW W-W

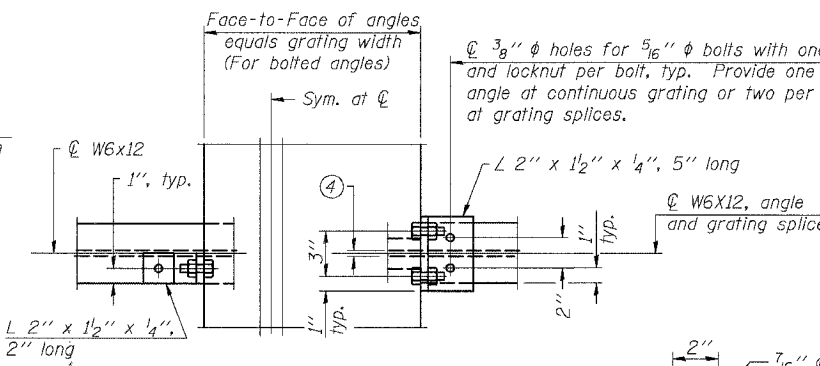

ALTERNATE FORMED PLANK GRATING DETAILS

Plank Grating: nominal depth = 2 1/2" (± 1/2"); perforated or expanded steel sheet with a non-skid surface (non-serrated) concentrated load capacity = 500 lbs. with 6'-0" clear span.

DETAIL H

Welds 3/16" continuous

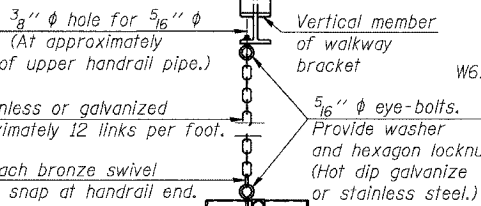

SAFETY CHAIN

One (1) required for each end of each walkway.

SECTION F-F LIGHTING FIXTURE MOUNTS

(If required)
NOTES

- Drilling holes in grating may be done in shop or field, based on Contractor's preference and subject to accurate alignment. Field drilled holes must be touched up with galvanized paint.
- Horizontal rail member shall be continuous thru 1 1/4" * pipe. Provide 7/16" * hole in fitting for 3/8" * bolt. Field drill 7/16" * hole in horizontal rail member. Provide washer and locknut for bolt. *Use 5/16" eyebolts in 7/16" * holes on top rail at ends only.*
- Install standard force-fit end caps or weld 1/8" end plates with 1/8" c.f.w. and grind smooth. *All rail ends.*
- 3/8" * 1/4" * gap between grating panels at splice.
- Chain to be hot dip galvanized after manufacture or stainless steel suitable for prolonged exterior exposure. Approximately 3'-6" long chain per location. Maximum sag with handrail erected = 4".
- 1/8" x 1/2" x 2" welded to handrail posts to protect locations that contact grating.
- Extrusions may be used in lieu of details shown, with approval by Engineer.
- Field cut ends of light support channels shall be free of burrs or hazardous projections and coated with zinc-rich primer or equivalent.

Drill 3/8" holes in walkway and support for 5/16" bolts with flat washers under head and locknut. Provide one per angle for continuous grating and two per angle at grating splices.

62301 (2021-922 PT2 ETC 2324.6-1P) R-10

Face-to-Face of angles equals grating width plus 1/8" (For welded angles)

Single handrail hinge shown

L 2" x 1 1/2" x 1/4" 4" long

W6x12 and angle

(WALKWAY GRATING CONTINUOUS)

W6, angle and grating splice

L 2" x 1 1/2" x 1/4", 5" long

Handrail splice hinge shown

(AT WALKWAY GRATING SPLICE)

PLAN

L 2" x 1 1/2" x 1/4"

3/8" x 1 1/2" bearing bars, 1 3/16" O.C. cross bars 4" O.C.

WELDED BAR GRATING DETAILS

DETAIL F

DETAIL G

SGN-38

BRIDGE MOUNT SIGN STRUCTURES
WALKWAY DETAILS

ILLINOIS DEPARTMENT OF TRANSPORTATION
F.A.I. 94/90 (DAN RYAN EXPRESSWAY)
GARFIELD BLVD TO 31ST STREET (NB LOCAL LANES)
OVERHEAD SIGN STRUCTURES
(BRIDGE MOUNTED)

NUMBER	REVISION	DATE

DESIGNED	MSA	20
CHECKED	AS/AC	EXAMINED
DRAWN	RV	PASSED
CHECKED	MSA	ENGINEER OF BRIDGE DESIGN
		ENGINEER OF BRIDGES AND STRUCTURES

BM-4 Special 1/7/05

STATE OF ILLINOIS
DEPARTMENT OF TRANSPORTATION

ROUTE NO.	SECTION	COUNTY	TOTAL SHEETS	SHEET NO.
94/90	*	COOK	565	281
FED. ROAD DIST. NO. 7		ILLINOIS	FED. AID PROJECT	

* 62301 (2021-922 PT2 ETC 2324.6-1P) R-10

SHEET NO. -
- SHEETS

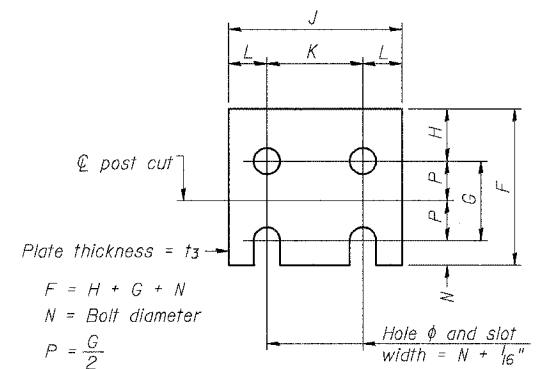
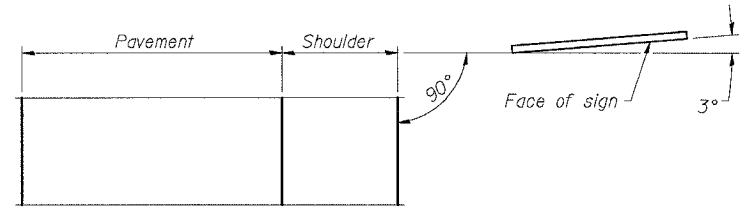
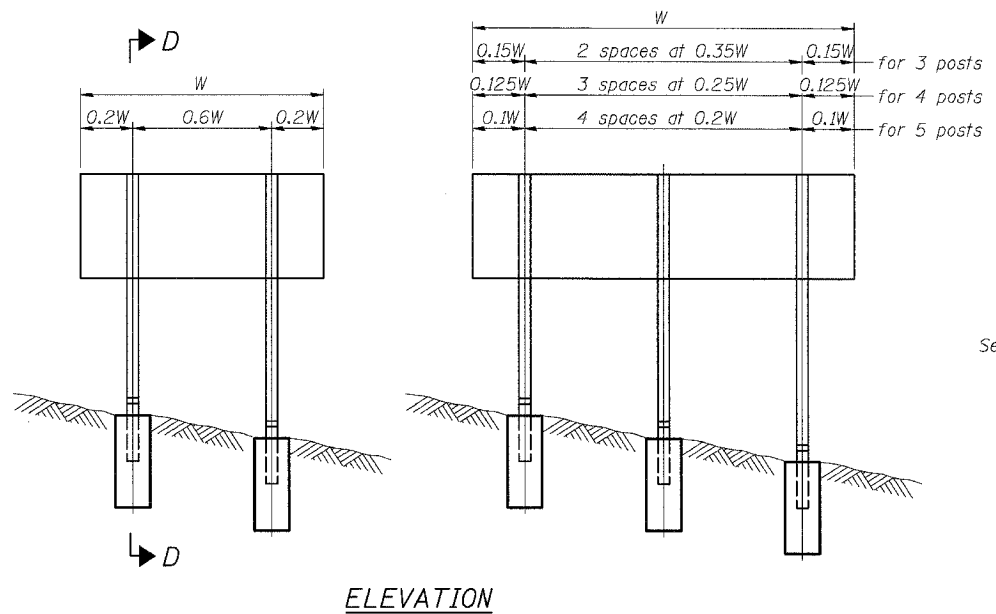

FUSE PLATE DATA		
N = Bolt Diameter	G	H
1/2"	2"	1 1/8"
5/8"	2 1/4"	1 1/4"
3/4"	2 1/2"	1 3/8"
7/8"	2 3/4"	1 1/2"
1"	3"	1 5/8"
1 1/8"	3 1/4"	1 3/4"

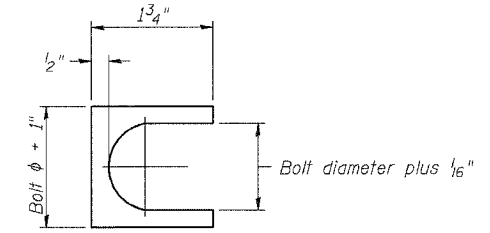
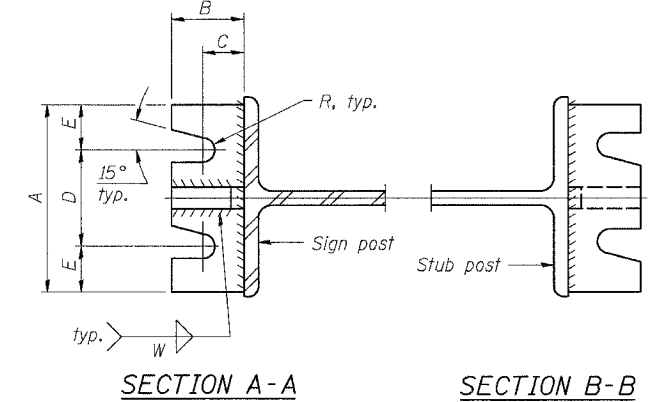
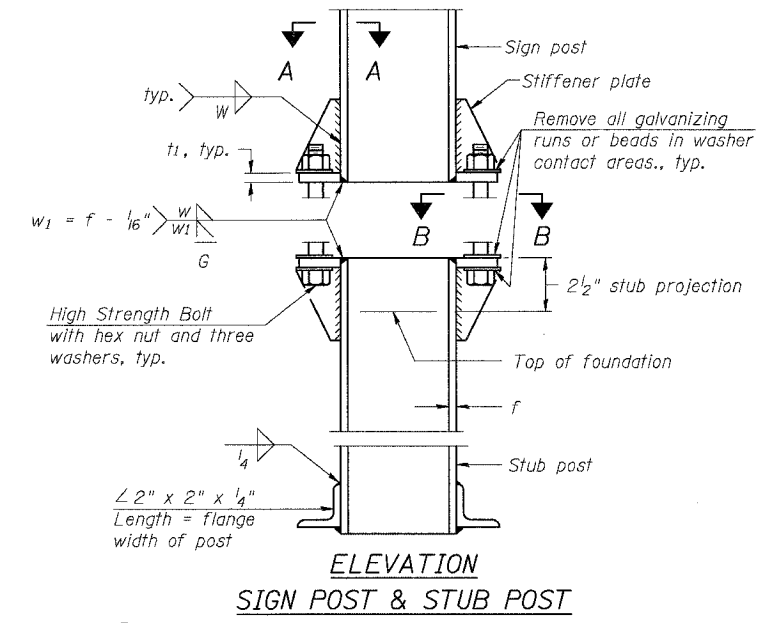
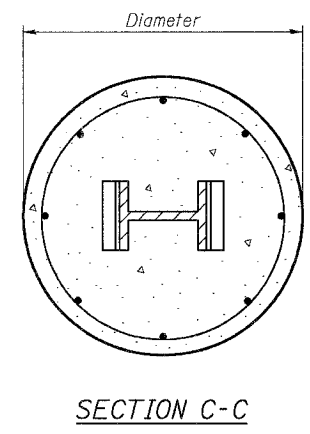
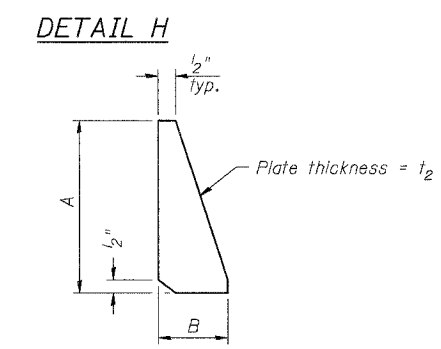
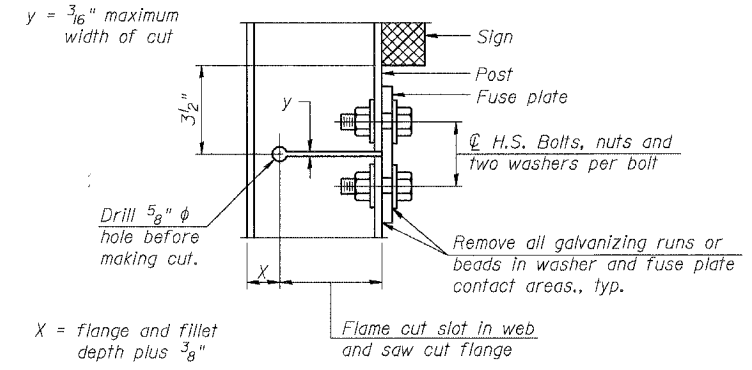
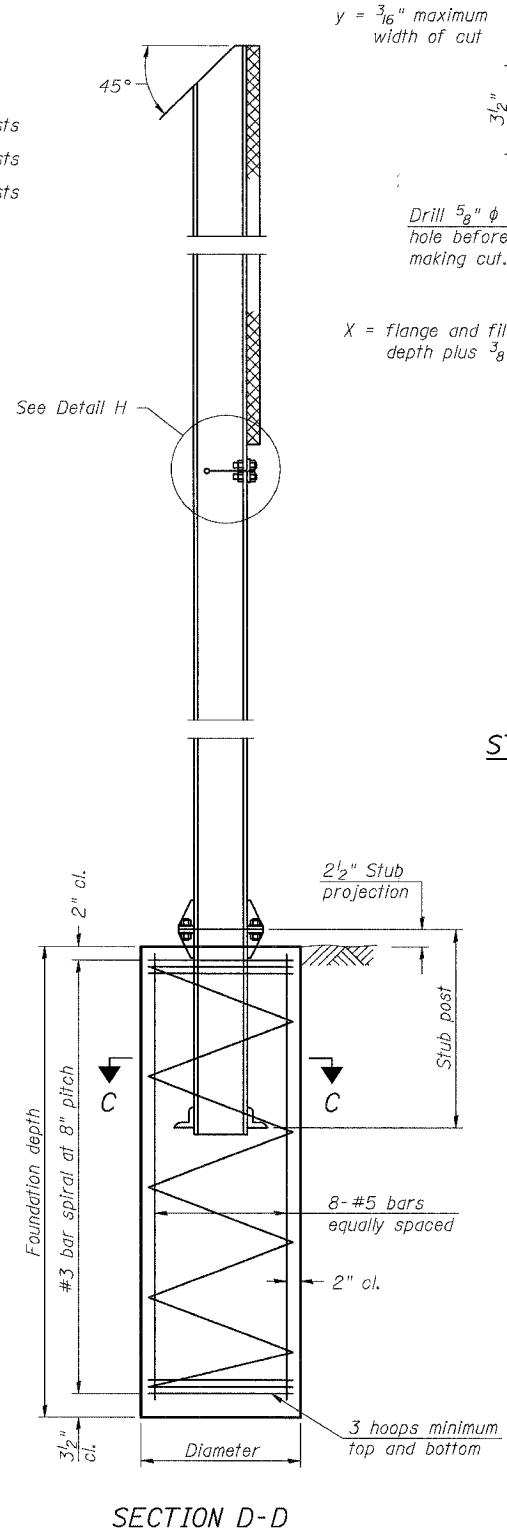

GENERAL NOTES

Posts shall be plumbed by using shims with post-to-stub post connection bolts snug tight only. Final tightening of all High Strength Bolts shall be in accordance with Article 505.04(f)(3), and threads at the junction of the bolt and nut shall be burred or center punched to prevent the nut from loosening.

LOADING: 80 m.p.h. wind with 30% gust factor, normal to sign.

DESIGN STRESSES:
Structural steel - 20,000 p.s.i.
Reinforcing steel - 20,000 p.s.i.
Concrete - 1,400 p.s.i.
Footing soil pressure - 2,000 p.s.f.

After fabrication, the post, fuse plate and upper 6", min. of the stub post shall be hot-dip galvanized in accordance with AASHTO M111. All bolts, nuts and washers shall be hot-dip galvanized in accordance with AASHTO M232.

Work this sheet with Base Sheet BAW-A-2.

Furnish two 0.01" thick and two 0.03" thick stainless steel or brass (ASTM B36) shims per post.

**BREAK-AWAY WIDE FLANGE
STEEL SIGN POST DETAILS**

ILLINOIS DEPARTMENT OF TRANSPORTATION

F.A.I. 94/90 (DAN RYAN EXPRESSWAY)
GARFIELD BLVD TO 31ST STREET (NB LOCAL LANES)
GROUND MOUNT SIGN STRUCTURES

GM-1

DESIGNED	20
CHECKED	EXAMINED
DRAWN	PASSED
CHECKED	ENGINEER OF BRIDGES AND STRUCTURES

BAW-A-1 1-7-05

NUMBER	REVISION	DATE

6/17/2006 1:50:10 PM

STATE OF ILLINOIS
DEPARTMENT OF TRANSPORTATION

ROUTE NO.	SECTION	COUNTY	TOTAL SHEETS	SHEET NO.
94/90		COOK	565	282
FED. ROAD DIST. NO. 7		ILLINOIS	FED. AID PROJECT	

* 62301 (2021-922 PT2 ETC 2324.6-1P) R-10

POST	CONCRETE FOUNDATION TABLE							POST TO STUB POST CONNECTION DATA										FUSE PLATE DATA				
	Foundation			Reinforcement				Stub Post Length	Bolt Size	A	B	C	D	E	t ₁	t ₂	R	W	J	K	L	t ₃
	Diameter	* Minimum Depth	Concrete (1) cu. yds.)	Vertical Bars Length	Bar Spirals Diameter	Bar Spirals Length	lbs. (2)															
W6x9	2'-0"	6'-0"	0.70	5'-9"	1'-8 1/2"	79'-0"	78	2'-3"	5/8" x 3/4"	6"	2 1/4"	1 1/4"	3 1/2"	1 1/4"	3/4"	1/2"	1 1/2"	1/4"	4"	2 1/4"	7/8"	1/4"
W6x15	2'-0"	6'-0"	0.70	5'-9"	1'-8 1/2"	79'-0"	78	2'-6"	5/8" x 3/4"	6"	2 1/4"	1 1/4"	3 1/2"	1 1/4"	3/4"	1/2"	1 1/2"	1/4"	6"	3 1/2"	1 1/4"	3/8"
W8x18	2'-0"	6'-0"	0.70	5'-9"	1'-8 1/2"	79'-0"	78	2'-6"	3/4" x 3/4"	6"	2 1/2"	1 3/8"	3 1/4"	1 3/8"	1"	1/2"	1 1/2"	5/16"	5 1/4"	2 3/4"	1 1/4"	3/8"
W10x22	2'-6"	6'-6"	1.18	6'-3"	2'-2 1/2"	105'-0"	92	3'-0"	3/4" x 3/4"	6"	2 1/2"	1 3/8"	3 1/4"	1 3/8"	1"	1/2"	1 1/2"	5/16"	5 3/4"	2 3/4"	1 1/2"	1/2"
W10x26	2'-6"	7'-0"	1.27	6'-9"	2'-2 1/2"	112'-0"	98	3'-0"	7/8" x 4"	7"	2 3/4"	1 1/2"	4"	1 1/2"	1"	3/4"	5/32"	3/8"	5 3/4"	2 3/4"	1 1/2"	5/8"
W12x26	2'-6"	7'-9"	1.41	7'-6"	2'-2 1/2"	119'-0"	107	3'-0"	7/8" x 4"	7"	2 3/4"	1 1/2"	4"	1 1/2"	1"	3/4"	5/32"	3/8"	6 1/2"	3 1/2"	1 1/2"	5/8"
W14x30	3'-0"	7'-3"	1.90	7'-0"	2'-8 1/2"	145'-0"	113	3'-0"	7/8" x 4"	7"	2 3/4"	1 1/2"	4"	1 1/2"	1"	3/4"	5/32"	3/8"	6 3/4"	3 1/2"	1 5/8"	1/2"
W14x38	3'-0"	8'-0"	2.09	7'-9"	2'-8 1/2"	153'-0"	122	3'-6"	1" x 4 1/2"	7 1/2"	3"	1 3/4"	4"	1 3/4"	1 1/4"	3/4"	1/32"	3/8"	6 3/4"	3 1/2"	1 5/8"	1/2"
W16x45	3'-0"	8'-6"	2.23	8'-3"	2'-8 1/2"	162'-0"	130	3'-6"	1" x 4 1/2"	7 1/2"	3"	1 3/4"	4"	1 3/4"	1 1/4"	3/4"	1/32"	3/8"	7"	3 1/2"	1 3/4"	1/2"

*Dimensional changes required for varying site conditions shall be approved by the Engineer.

POST	FUSE PLATE BOLT SIZE													
	Sign Depth													
	4'-0"	5'-0"	6'-0"	7'-0"	8'-0"	9'-0"	10'-0"	11'-0"	12'-0"	13'-0"	14'-0"	15'-0"	16'-0"	
W6x9	1/2" x 1 1/2"	1/2" x 1 1/2"	1/2" x 1 1/2"	5/8" x 1 3/4"	5/8" x 1 3/4"	5/8" x 1 3/4"	---	---	---	---	---	---	---	
W6x15	1/2" x 1 3/4"	1/2" x 1 3/4"	5/8" x 2"	5/8" x 2"	3/4" x 2"	3/4" x 2"	3/4" x 2"	3/4" x 2"	7/8" x 2"	7/8" x 2"	---	---	---	
W8x18	1/2" x 1 3/4"	1/2" x 1 3/4"	1/2" x 1 3/4"	5/8" x 2"	5/8" x 2"	3/4" x 2"	3/4" x 2"	7/8" x 2 1/4"	7/8" x 2 1/4"	7/8" x 2 1/4"	7/8" x 2 1/4"	7/8" x 2 1/4"	7/8" x 2 1/4"	
W10x22	1/2" x 2"	1/2" x 2"	1/2" x 2"	5/8" x 2"	5/8" x 2"	3/4" x 2 1/4"	3/4" x 2 1/4"	7/8" x 2 1/4"	7/8" x 2 1/4"	7/8" x 2 1/2"	1" x 2 1/2"	1" x 2 3/4"	1" x 2 3/4"	
W10x26	1/2" x 2"	1/2" x 2"	1/2" x 2"	5/8" x 2 1/4"	5/8" x 2 1/4"	3/4" x 2 1/2"	3/4" x 2 1/2"	7/8" x 2 1/2"	7/8" x 2 1/2"	1" x 2 3/4"	1" x 2 3/4"	1" x 2 3/4"	1 1/8" x 3"	
W12x26	---	---	---	---	---	5/8" x 2 1/4"	---	---	7/8" x 2 1/2"	7/8" x 2 1/2"	1" x 2 1/2"	1" x 2 3/4"	1" x 2 3/4"	
W14x30	1/2" x 2"	1/2" x 2"	1/2" x 2"	1/2" x 2"	1/2" x 2"	5/8" x 2"	3/4" x 2 1/4"	3/4" x 2 1/4"	3/4" x 2 1/4"	7/8" x 2 1/2"	1" x 2 1/2"	1" x 2 3/4"	1" x 2 3/4"	
W14x38	---	1/2" x 2"	1/2" x 2"	1/2" x 2"	1/2" x 2"	5/8" x 2 1/4"	3/4" x 2 1/4"	3/4" x 2 1/2"	3/4" x 2 1/2"	7/8" x 2 1/2"	7/8" x 2 1/2"	1" x 2 1/2"	1" x 2 3/4"	
W16x45	---	---	---	1/2" x 2"	1/2" x 2"	5/8" x 2 1/4"	5/8" x 2 1/4"	3/4" x 2 1/4"	3/4" x 2 1/2"	3/4" x 2 1/2"	7/8" x 2 1/2"	7/8" x 2 1/2"	1" x 2 3/4"	

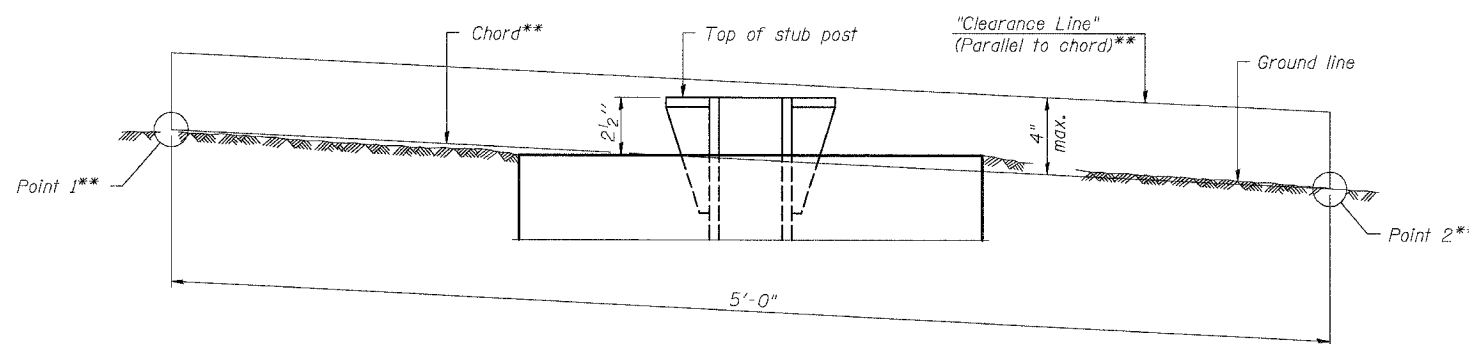

ELEVATION
GROUND LINE & STUB POST

** For all "Point 1" and "Point 2" locations, "Clearance Line" must be at or above top of stub post.

- (1) Quantity includes all concrete necessary for one foundation.
- (2) Includes reinforcement bars and spiral hooping for one foundation.

DESIGNED	20
CHECKED	EXAMINED
DRAWN	PASSED
CHECKED	ENGINEER OF BRIDGES AND STRUCTURES

NUMBER	REVISION	DATE

BAW-A-2

1-7-05

BREAK-AWAY WIDE FLANGE
STEEL SIGN POST TABLES
ILLINOIS DEPARTMENT OF TRANSPORTATION
F.A.I. 94/90 (DAN RYAN EXPRESSWAY)
GARFIELD BLVD TO 31ST STREET (NB LOCAL LANES)
GROUND MOUNT SIGN STRUCTURES

(Sheet 2 of 2)

ROUTE	SIGN NO.	STATION	SIGN PANEL			SIZE	POSTS			DISTANCES			QUANTITIES			REMARKS
			H	W	NO.		L ₁	L ₂	L ₃	A	B	C	STRUCT. STEEL LBS.	CONCRETE CU. YDS.		
I-90/94	PS04-05	4549+50	5	9	2	6"X6" WOOD	18	18	-	1.80	5.40	-	-	-	EXIT "56A"	
	PS05-04	4574+40	5	9	2	6"X6" WOOD	18	18	-	1.80	5.40	-	-	-	EXIT "55B"	
	PS06-02	4587+22	5	9	2	6"X6" WOOD	18	18	-	1.80	5.40	-	-	-	EXIT "55A"	
	PS08-01	4629+38	5	7.5	2	6"X6" WOOD	18	18	-	1.80	5.40	-	-	-	EXIT "54"	

- NOTES:**
1. CONTRACTOR AND RESIDENT ENGINEER SHALL DETERMINE EXACT LENGTHS REQUIRED BEFORE ORDERING SUPPORTS.
 2. RESIDENT ENGINEER TO DETERMINE FINAL PLACEMENT OF EXIT SIGNS.
 3. THE MINIMUM CLEAR HEIGHT IS 7'-0".

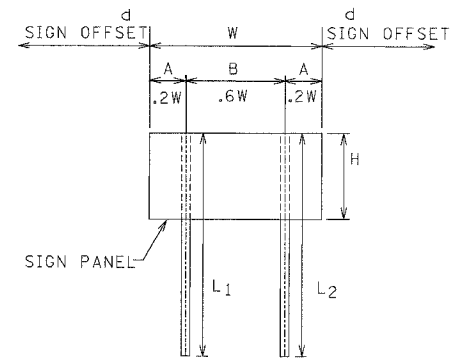
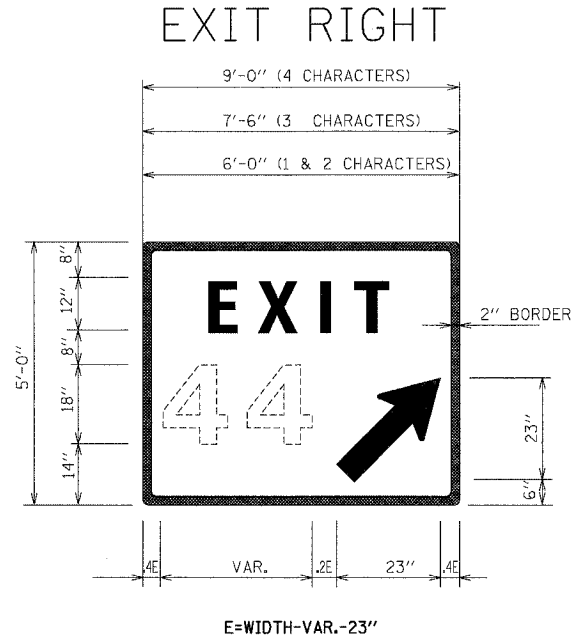

TYPICAL 2 POST EXIT PANEL

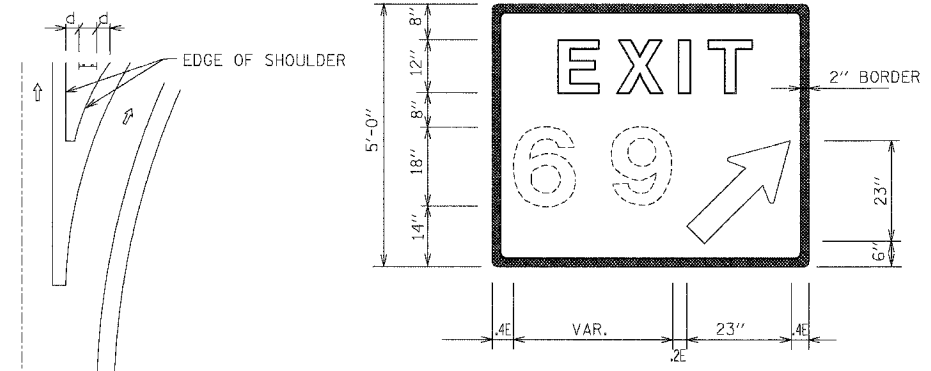

DIGITS	W	d
1 OR 2	6'-0"	2'-0"
3	7'-6"	1'-3"

E=WIDTH-VAR.-23"

GORE SIGNS

REVISIONS		ILLINOIS DEPARTMENT OF TRANSPORTATION F.A.I. 94/90 (DAN RYAN EXPRESSWAY) GARFIELD BLVD TO 31ST ST (NB LOCAL LANES) GROUND MOUNT EXIT SIGN
NAME	DATE	
		SCALE: NONE DATE: 06/09/06 DRAWN BY: RV CHECKED BY: AS

m:\660\cadd\ex11\B\SHEETS\Ext sign.sht
6/7/2006

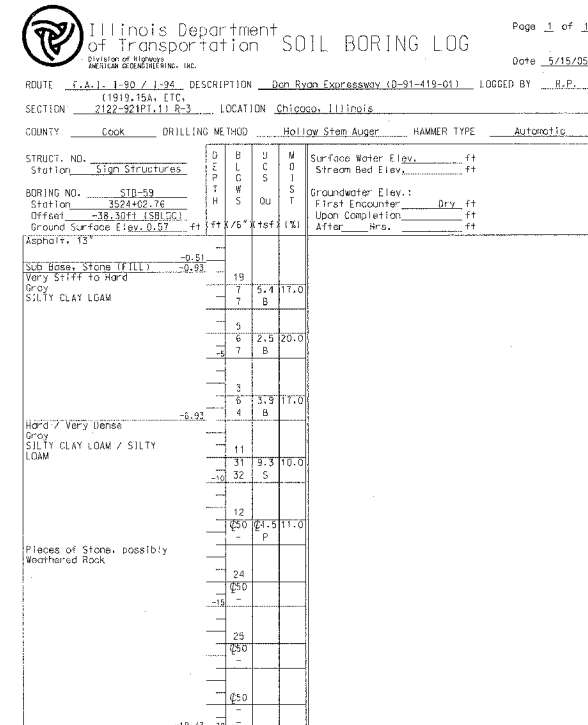
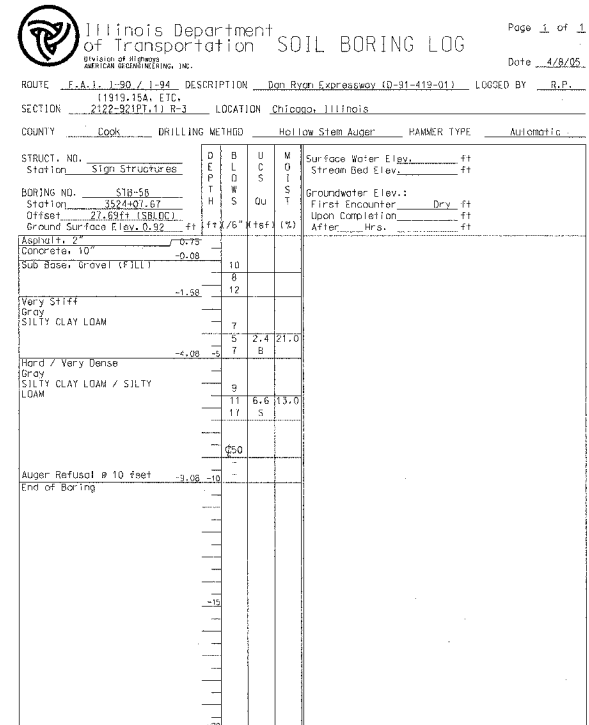
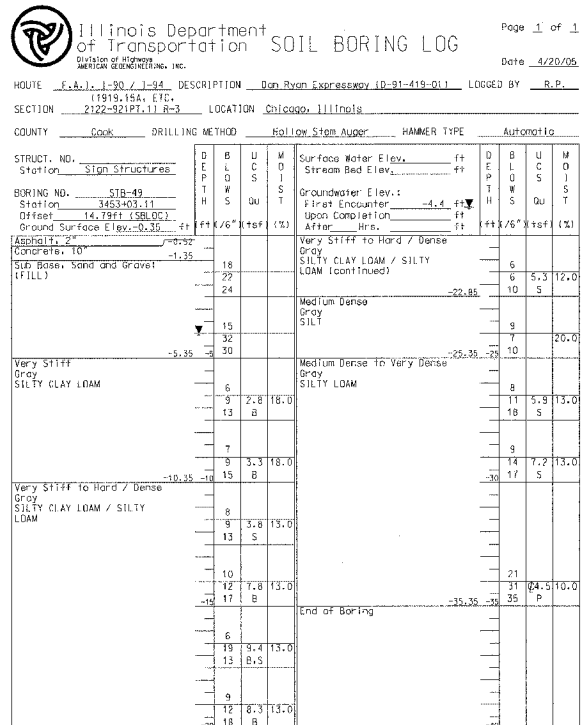

The Unconfined Compressive Strength (UCS) Failure Mode is indicated by (B-Bulge, S-Shear, P-Penetrometer). The SPT (N value) is the sum of the last two blow values in each sampling zone (ASHTO 1206) BBS, from 137 (Rev. 8-99)

The Unconfined Compressive Strength (UCS) Failure Mode is indicated by (B-Bulge, S-Shear, P-Penetrometer). The SPT (N value) is the sum of the last two blow values in each sampling zone (ASHTO 1206) BBS, from 137 (Rev. 8-99)

The Unconfined Compressive Strength (UCS) Failure Mode is indicated by (B-Bulge, S-Shear, P-Penetrometer). The SPT (N value) is the sum of the last two blow values in each sampling zone (ASHTO 1206) BBS, from 137 (Rev. 8-99)

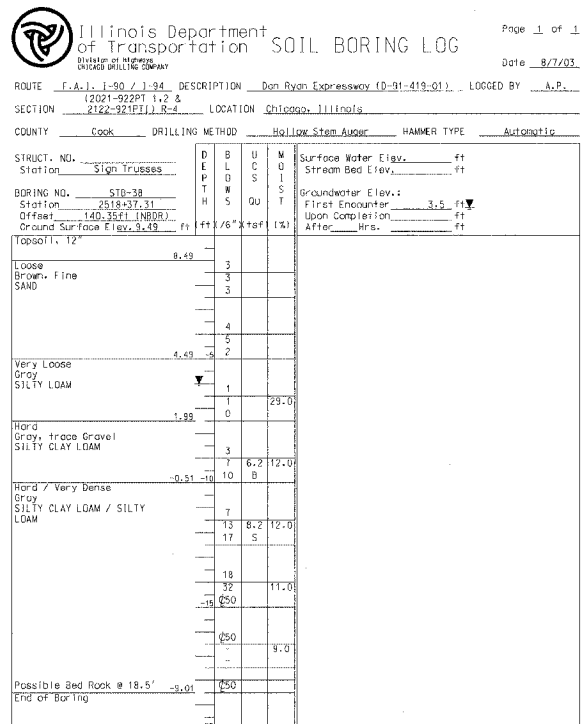

The Unconfined Compressive Strength (UCS) Failure Mode is indicated by (B-Bulge, S-Shear, P-Penetrometer). The SPT (N value) is the sum of the last two blow values in each sampling zone (ASHTO 1206) BBS, from 137 (Rev. 8-99)

REVISIONS		ILLINOIS DEPARTMENT OF TRANSPORTATION F.A.I. 90/94 (DAN RYAN EXPRESSWAY) GARFIELD BLVD TO 31ST STREET (NB LOCAL LANES) SOIL BORING LOGS FOR SIGN STRUCTURE FOUNDATIONS
NAME	DATE	

SCALE: NONE DRAWN BY: SLW
DATE: June 9, 2006 CHECKED BY: PJD

Illinois Department of Transportation SOIL BORING LOG Page 1 of 1
 Date 4/6/05
 ROUTE F.A.I. 1-90 / 1-94 DESCRIPTION Dan Ryan Expressway (D-91-419-01) LOGGED BY R.P.
 SECTION 2122-921 PT 1.1 B-3 LOCATION Chicago, Illinois

COUNTY	Cook	DRILLING METHOD	Hollow Stem Auger				HAMMER TYPE	Automatic			
			D	B	U	M		D	B	U	M
STRUCT. NO.	Sign Structures										
Station	486484.69										
BORING NO.	STB-54										
Station	486484.69										
Offset	-12.734 (NBLUC)										
Ground Surface Elev.	5.19										
Asphalt, 2"	-0.02										
Concrete, 10"	3.15										
Sub Base, Gravel (FILL)	20										
Very Loose to Medium Dense Brown, coarse SAND, trace Gravel	1.68										
Hard / Very Dense Gray SILTY CLAY LOAM / SILTY LOAM	-20.81										
Very Stiff to Hard Gray SILTY CLAY LOAM	-4.81										
Very Stiff to Hard Gray SILTY CLAY LOAM	-10										
Piece of Stone Stuck @ Tip of Spoon	-10										
End of Boring	-30.81										

The Unconfined Compressive Strength (UCS) Failure Mode is indicated by (B-Bulge, S-Shear, P-Penetrometer). The SPT (N value) is the sum of the last two blow values in each sampling zone (AASHTO T206) BSS, from 137 (Rev. 8-99)

Illinois Department of Transportation SOIL BORING LOG Page 1 of 1
 Date 4/6/05
 ROUTE F.A.I. 1-90 / 1-94 DESCRIPTION Dan Ryan Expressway (D-91-419-01) LOGGED BY R.P.
 SECTION 2122-921 PT 1.1 B-3 LOCATION Chicago, Illinois

COUNTY	Cook	DRILLING METHOD	Hollow Stem Auger				HAMMER TYPE	Automatic			
			D	B	U	M		D	B	U	M
STRUCT. NO.	Sign Structures										
Station	4505482.00										
BORING NO.	STB-55										
Station	4505482.00										
Offset	-13.077 (NBLUC)										
Ground Surface Elev.	0.14										
Asphalt, 2"	-0.26										
Concrete, 10"	-1.76										
Sub Base, Gravel (FILL)	12										
Very Stiff Gray CLAY	-4.26										
Very Stiff to Hard Gray SILTY CLAY LOAM	-8.26										
Hard / Very Dense Gray SILTY CLAY LOAM / SILTY LOAM	-9.26										
Piece of Stone Stuck @ Tip of Spoon	-10										
End of Boring	-34.26										

The Unconfined Compressive Strength (UCS) Failure Mode is indicated by (B-Bulge, S-Shear, P-Penetrometer). The SPT (N value) is the sum of the last two blow values in each sampling zone (AASHTO T206) BSS, from 137 (Rev. 8-99)

Illinois Department of Transportation SOIL BORING LOG Page 1 of 1
 Date 4/7/05
 ROUTE F.A.I. 1-90 / 1-94 DESCRIPTION Dan Ryan Expressway (D-91-419-01) LOGGED BY R.P.
 SECTION 2122-921 PT 1.1 B-3 LOCATION Chicago, Illinois

COUNTY	Cook	DRILLING METHOD	Hollow Stem Auger				HAMMER TYPE	Automatic			
			D	B	U	M		D	B	U	M
STRUCT. NO.	Sign Structures										
Station	8081446.05										
BORING NO.	STB-56										
Station	8081446.05										
Offset	3.941										
Ground Surface Elev.	12.35										
Asphalt, 3"	-0.76										
Concrete, 9"	-11.86										
Sub Base, Gravel (FILL)	8										
Medium Dense Brown SAND, some Gravel	10.45										
Hard / Dense Gray SILTY CLAY LOAM / SILTY LOAM	-16										
Very Stiff Gray CLAY	-22										
Very Stiff to Hard Gray SILTY CLAY LOAM	-26										
Loose Gray SILTY LOAM	-34										
Very Stiff Gray CLAY	-40										
Very Stiff to Hard Gray SILTY CLAY LOAM	-46										
End of Boring	-52										

The Unconfined Compressive Strength (UCS) Failure Mode is indicated by (B-Bulge, S-Shear, P-Penetrometer). The SPT (N value) is the sum of the last two blow values in each sampling zone (AASHTO T206) BSS, from 137 (Rev. 8-99)

Illinois Department of Transportation SOIL BORING LOG Page 1 of 1
 Date 4/9/05
 ROUTE F.A.I. 1-90 / 1-94 DESCRIPTION Dan Ryan Expressway (D-91-419-01) LOGGED BY R.P.
 SECTION 2122-921 PT 1.1 B-3 LOCATION Chicago, Illinois

COUNTY	Cook	DRILLING METHOD	Hollow Stem Auger				HAMMER TYPE	Automatic			
			D	B	U	M		D	B	U	M
STRUCT. NO.	Sign Structures										
Station	4518442.04										
BORING NO.	STB-57										
Station	4518442.04										
Offset	-42.387 (NBLUC)										
Ground Surface Elev.	2.94										
Asphalt, 2"	-0.84										
Concrete, 10"	8.04										
Sub Base, Gravel (FILL)	15										
Medium Dense Brown SAND	6.28										
Loose Gray SILTY LOAM	4.04										
Very Stiff Gray SILTY CLAY LOAM	-1.54										
Hard / Dense Gray SILTY CLAY LOAM / SILTY LOAM	-0.96										
No Recovery	-15										
End of Boring	-10.96										

The Unconfined Compressive Strength (UCS) Failure Mode is indicated by (B-Bulge, S-Shear, P-Penetrometer). The SPT (N value) is the sum of the last two blow values in each sampling zone (AASHTO T206) BSS, from 137 (Rev. 8-99)

Illinois Department of Transportation SOIL BORING LOG Page 1 of 2
 Date 3/6/03
 ROUTE F.A.I. 1-90 / 1-94 DESCRIPTION Dan Ryan Expressway (D-91-419-01) LOGGED BY D.G.
 SECTION 2122-922 PT 1.2 & 2122-921 P111R-4 LOCATION Chicago, Illinois

COUNTY	Cook	DRILLING METHOD	Hollow Stem Auger				HAMMER TYPE	Automatic			
			D	B	U	M		D	B	U	M
STRUCT. NO.	016-W899										
Station	(Wall - W)										
BORING NO.	REW-25										
Station	178+29.31										
Offset	4.987 (NW)										
Ground Surface Elev.	15.66										
Asphalt, 2"	-16.49										
Concrete, 11"	15.58										
Sub Base (FILL)	14.16										
Medium Dense to Very Loose Brown, Fine to Coarse SAND, trace Gravel (Possible Bog FILL)	-4										
Very Stiff Gray SILTY CLAY LOAM	-8.34										
Very Loose Gray SILTY LOAM	-4.16										
Stiff Gray CLAY	-10										
Saturated	-15										

The Unconfined Compressive Strength (UCS) Failure Mode is indicated by (B-Bulge, S-Shear, P-Penetrometer). The SPT (N value) is the sum of the last two blow values in each sampling zone (AASHTO T206) BSS, from 137 (Rev. 8-99)

Illinois Department of Transportation SOIL BORING LOG Page 2 of 2
 Date 3/6/03
 ROUTE F.A.I. 1-90 / 1-94 DESCRIPTION Dan Ryan Expressway (D-91-419-01) LOGGED BY D.G.
 SECTION 2122-922 PT 1.2 & 2122-921 P111R-4 LOCATION Chicago, Illinois

COUNTY	Cook	DRILLING METHOD	Hollow Stem Auger				HAMMER TYPE	Automatic			
			D	B	U	M		D	B	U	M
STRUCT. NO.	016-W899										
Station	(Wall - W)										
BORING NO.	REW-25										
Station	178+29.31										
Offset	4.987 (NW)										
Ground Surface Elev.	15.66										
Very Stiff Gray SILTY CLAY LOAM (continued)	-10										
Hard / Very Dense Gray SILTY CLAY LOAM / SILTY LOAM (continued)	-15										
Pieces of Rock Possible Bed Rock @ 63'	-28.34										
End of Boring	-48.34										
Saturated	-40										

The Unconfined Compressive Strength (UCS) Failure Mode is indicated by (B-Bulge, S-Shear, P-Penetrometer). The SPT (N value) is the sum of the last two blow values in each sampling zone (AASHTO T206) BSS, from 137 (Rev. 8-99)



REVISIONS	
NAME	DATE

ILLINOIS DEPARTMENT OF TRANSPORTATION
 F.A.I. 90/94 (DAN RYAN EXPRESSWAY)
 GARFIELD BLVD TO 31ST STREET (NB LOCAL LANES)

SOIL BORING LOGS FOR
 SIGN STRUCTURE FOUNDATIONS

SCALE: NONE
 DATE: June 9, 2006
 DRAWN BY: SLW
 CHECKED BY: PJO

F:\94\668\WIN\B-Cutts 18 & 19\3\F\Contr 18\85822A.dwg 11/26/23 AM 6/7/2006

Everest Engineering Company
STRUCTURE BORING LOG
Page 1 of 1
Date 8/26/03

ROUTE FAI 90/94 DESCRIPTION DAN RYAN EXPRESSWAY
SECT. 31ST STREET TO 47TH STREET DRILLED BY PATRICK DRILLING
COUNTY COOK LOCATION OVERHEAD SIGN STRUCTURE S. TWP. 38 N., RNG. 14 E.

Boring No. OVN1B1
Station 4538+57 (NB LOCAL)
Offset 43 FT. OF NB LOCAL BL
Surface Elev. 11.30 ft

Description	Depth (ft)	D		Qu	W	S	P	Surface Water Elev.	Groundwater Elev. when drilling at Completion after Hrs.
		Blow	Pen						
ASPHALT PAVEMENT	10.8								
CRUSHED STONE	10.3	3	2						
Loose, Brown and Gray SANDY LOAM trace to little crushed stone	8.3	23	4					-16.7	
FILL		16							
Medium Dense, Brown Fine to Coarse SAND trace to little gravel	5.8	11						-18.7	
Very Loose to Loose, Gray SILTY LOAM trace-gravel		3	17						
		4							
		0	27						
		1							
		0	20						
		1							
Medium Stiff to Stiff, Gray SILTY CLAY trace-gravel	-1.7	0	0.5	23					
		2	B						
		2	B						
		3							
		1	0.5	22					
		3	B						
		3							
		1	1.0	15					
		3	B						
		2	1.2	19					
		3	B						
		5							

SPT (N) = Sum of last two blow values in sample. (Cu) B=Blow S=Shear P=Penetration Test
Stations, Depths, Offset, and Elevations are in Feet

Everest Engineering Company
STRUCTURE BORING LOG
Page 1 of 1
Date 8/26/03

ROUTE FAI 90/94 DESCRIPTION DAN RYAN EXPRESSWAY
SECT. 31ST STREET TO 47TH STREET DRILLED BY PATRICK DRILLING
COUNTY COOK LOCATION OVERHEAD SIGN STRUCTURE S. TWP. 38 N., RNG. 14 E.

Boring No. OVN1B2
Station 4549+27 (NB LOCAL)
Offset 66 FT. OF NB LOCAL BL
Surface Elev. 8.40 ft

Description	Depth (ft)	D		Qu	W	S	P	Surface Water Elev.	Groundwater Elev. when drilling at Completion after Hrs.
		Blow	Pen						
ASPHALT PAVEMENT	7.7								
CRUSHED STONE	7.4	6	7						
Loose to Medium Dense, Brown SANDY LOAM trace-gravel		2							
		2							
		8	26						
		6							
		6							
Very Loose, Gray SILTY LOAM trace-gravel	2.9	0	28						
		1							
		0							
		1	27						
		2							
		0	27						
		1							
		0	20						
		1							
Medium Stiff to Stiff, Gray SILTY CLAY trace-gravel	-2.1	1	1.8	25					
		2	B						
		4							
		0	1.0	23					
		3	B						
		4							
		0	0.8	24					
		2	B						
		3							
		6	1.7	20					
		50/2"	B						
END OF BORING (AUGER REFUSAL)	-11.6								

SPT (N) = Sum of last two blow values in sample. (Cu) B=Blow S=Shear P=Penetration Test
Stations, Depths, Offset, and Elevations are in Feet

Everest Engineering Company
STRUCTURE BORING LOG
Page 1 of 1
Date 8/27/03

ROUTE FAI 90/94 DESCRIPTION DAN RYAN EXPRESSWAY
SECT. 31ST STREET TO 47TH STREET DRILLED BY PATRICK DRILLING
COUNTY COOK LOCATION OVERHEAD SIGN STRUCTURE S. TWP. 38 N., RNG. 14 E.

Boring No. OVN1B4
Station 4570+81 (NB LOCAL)
Offset 66 FT. OF NB LOCAL BL
Surface Elev. -2.10 ft

Description	Depth (ft)	D		Qu	W	S	P	Surface Water Elev.	Groundwater Elev. when drilling at Completion after Hrs.
		Blow	Pen						
ASPHALT PAVEMENT	-2.6								
CRUSHED STONE		10	21						
		14							
		8	3						
		20							
		13							
FILL		0	1.0	22					
Stiff, Gray SILTY CLAY trace-gravel	-7.6	2	B						
		3							
		0	1.0	22					
		2	B						
		3							
		0	1.0	22					
		2	B						
		3							
Very Stiff, Gray SILTY CLAY LOAM trace-gravel	-12.6	5	3.0	12					
		8	P						
		11							
Very Dense to Extremely Dense, Gray SILTY LOAM trace-gravel	-15.1	9		11					
		38							
		42							
		38		7					
		50/2"							
		24		8					
		50/5"							
END OF BORING (AUGER REFUSAL)	-22.1								

SPT (N) = Sum of last two blow values in sample. (Cu) B=Blow S=Shear P=Penetration Test
Stations, Depths, Offset, and Elevations are in Feet

Everest Engineering Company
STRUCTURE BORING LOG
Page 1 of 1
Date 8/27/03

ROUTE FAI 90/94 DESCRIPTION DAN RYAN EXPRESSWAY
SECT. 31ST STREET TO 47TH STREET DRILLED BY PATRICK DRILLING
COUNTY COOK LOCATION OVERHEAD SIGN STRUCTURE S. TWP. 38 N., RNG. 14 E.

Boring No. OVN1B7
Station 4598+81 (NB LOCAL)
Offset 58 FT. OF NB LOCAL BL
Surface Elev. 10.10 ft

Description	Depth (ft)	D		Qu	W	S	P	Surface Water Elev.	Groundwater Elev. when drilling at Completion after Hrs.
		Blow	Pen						
ASPHALT PAVEMENT	9.7								
CRUSHED STONE		16	3						
		20							
		23							
		14	5						
		23							
		14							
FILL		1	0.7	24					
Loose to Medium Dense, Gray SILTY LOAM	4.6	2							
		4							
		6							
		2	23						
		2							
		3	1.7	20					
		7	B						
		5							
Very Soft to Stiff, Gray SILTY CLAY trace-gravel	-0.4	1	0.4	25					
		1	B						
		1							
		1	0.7	24					
		1	B						
		4							
Hard, Gray SILTY CLAY LOAM trace-gravel	-27.9	11	4.8	10					
		16	B						
		24							
END OF BORING	-29.9								
		0	0.1	25					
		0	B						
		1							
		0	0.1	25					
		0	B						
		1							
		0	0.3	25					
		1	B						
		1							

SPT (N) = Sum of last two blow values in sample. (Cu) B=Blow S=Shear P=Penetration Test
Stations, Depths, Offset, and Elevations are in Feet

BOWMAN, BARRETT & ASSOCIATES INC.
CONSULTING ENGINEERS
Chicago, Illinois
312.228.0100
www.bbainc.com

REVISIONS	
NAME	DATE

ILLINOIS DEPARTMENT OF TRANSPORTATION
F.A.I. 94/90 (DAN RYAN EXPRESSWAY)
GARFIELD BLVD TO 31ST STREET (NB LOCAL LANES)
SOIL BORING LOGS FOR
SIGN STRUCTURE FOUNDATIONS

SCALE: NTS
DATE: 06/09/06

DRAWN BY: RA
CHECKED BY: RS

GENERAL PLAN NOTES - LANDSCAPING:

1. THE CONTRACTOR SHALL USE CARE IN GRADING OR EXCAVATING NEAR ANY AND ALL EXISTING ITEMS WHICH WILL NOT BE REMOVED. ANY DAMAGE DONE TO EXISTING ITEMS BY THE CONTRACTOR SHALL BE REPAIRED BY THE CONTRACTOR AT THE CONTRACTOR'S EXPENSE.
2. THE CONTRACTOR SHALL TAKE ALL NECESSARY PRECAUTIONS FOR THE PROTECTION OF EXISTING PLANT MATERIAL FOR WHICH THE CONTRACT DOES NOT PROVIDE REMOVAL. THE PROTECTION OF EXISTING PLANT MATERIAL AND THE REPAIR OR REPLACEMENT OF EXISTING PLANT MATERIAL DAMAGED BY THE CONTRACTOR SHALL BE DONE IN ACCORDANCE WITH THE REQUIREMENTS OF SECTION 201 OF THE STANDARD SPECIFICATIONS.
3. THE SEEDING DATES FOR BARE EARTH SEEDING OF MIXTURE CLASS 2A SHALL BE FROM APRIL 1 TO JUNE 1 AND FROM AUGUST 15 TO SEPTEMBER 30. ALL SEEDING NOT SOWN ACCORDING TO THE SPECIFIED SEASONAL DATE SHALL REQUIRE PRIOR APPROVAL FROM THE ENGINEER. FAILURE TO SECURE SUCH APPROVAL SHALL RESULT IN THE REJECTION OF THE SEEDING AND REPLACEMENT BY THE CONTRACTOR AS HIS/HER EXPENSE.
4. AREAS TO BE SEEDED BETWEEN NOVEMBER 15 AND MARCH 31 SHALL REQUIRE DORMANT SEEDING, WHICH SHALL BE INCLUDED IN THE COST OF "SEEDING CLASS 2A," "SEEDING CLASS 4 (MODIFIED)," OR "SEEDING, CLASS 5A (MODIFIED)."
5. THE SEEDING DATES FOR BARE EARTH SEEDING OF MIXTURE CLASSES 4 AND 5 SHALL BE FROM APRIL 15 TO JUNE 30 AND FROM OCTOBER 15 TO DECEMBER 1. ALL SEEDING NOT SOWN ACCORDING TO THE SPECIFIED SEASONAL DATE SHALL REQUIRE PRIOR APPROVAL FROM THE ENGINEER. FAILURE TO SECURE SUCH APPROVAL SHALL RESULT IN THE REJECTION OF THE SEEDING AND REPLACEMENT BY THE CONTRACTOR AS HIS/HER EXPENSE.
6. LAYOUT OF LANDSCAPED AREAS WILL REQUIRE APPROVAL OF THE ENGINEER PRIOR TO TOPSOIL PLACEMENT, SEEDING, AND PLANTING.

GENERAL PLAN NOTES - PLANTING BED:

7. SEE LANDSCAPING PLANS FOR SPECIFIC LOCATIONS AND QUANTITIES OF VINES, SHRUBS, AND DAYLILIES.
8. ALL COMPOST AND TOPSOIL AREAS SHALL BE THOROUGHLY ROTOTILLED TO A DEPTH OF 12" PRIOR TO PLANTING AND/OR SEEDING
9. THE CONTRACTOR SHALL ORDER THE FOLLOWING PLANT MATERIAL IMMEDIATELY FOLLOWING EXECUTION OF THE CONTRACT TO ASSURE AVAILABILITY OF THE PLANT MATERIAL FOR SPRING PLANTING AT THE CONCLUSION OF THE CONTRACT:
 - VINE-PARTHENOCISSUS QUINQUEFOLIA (VIRGINIA CREEPER), 1-GALLON
 - VINE-PARTHENOCISSUS TRICUSPIDATA (BOSTON IVY), 1-GALLON
 - PERENNIAL PLANTS, DAYLILIES (HAPPY RETURNS DAYLILY), 1-GALLON
10. MULCH BED SHALL BE PLACED OVER ROTOTILLED COMPOST/TOPSOIL AS SHOWN IN THE PLANTING DETAILS AND ACCORDING TO IDOT STANDARD SPECIFICATION 253.11. EXCEPT THAT NO WEED BARRIER FABRIC IS REQUIRED. COST OF MULCH COVER IS INCLUDED WITH PAYMENT FOR THE VINES, DAYLILIES, AND SHRUBS.
11. PRE-EMERGENT GRANULAR HERBICIDE SHALL BE PLACED IN MULCHED BEDS ACCORDING TO THE SPECIAL PROVISION.
12. FERTILIZER NUTRIENTS SHALL BE ADDED AND APPLIED TO THE VINE BEDS AT A 5:3:2 RATIO AS FOLLOWS:
 - NITROGEN FERTILIZER NUTRIENTS: 90 LBS/ACRE
 - PHOSPHORUS FERTILIZER NUTRIENTS: 54 LBS/ACRE
 - POTASSIUM FERTILIZER NUTRIENTS: 36 LBS/ACRE
 THIS FERTILIZER SHALL BE TILLED AND CULTIVATED INTO THE SOIL TO A DEPTH OF 12"

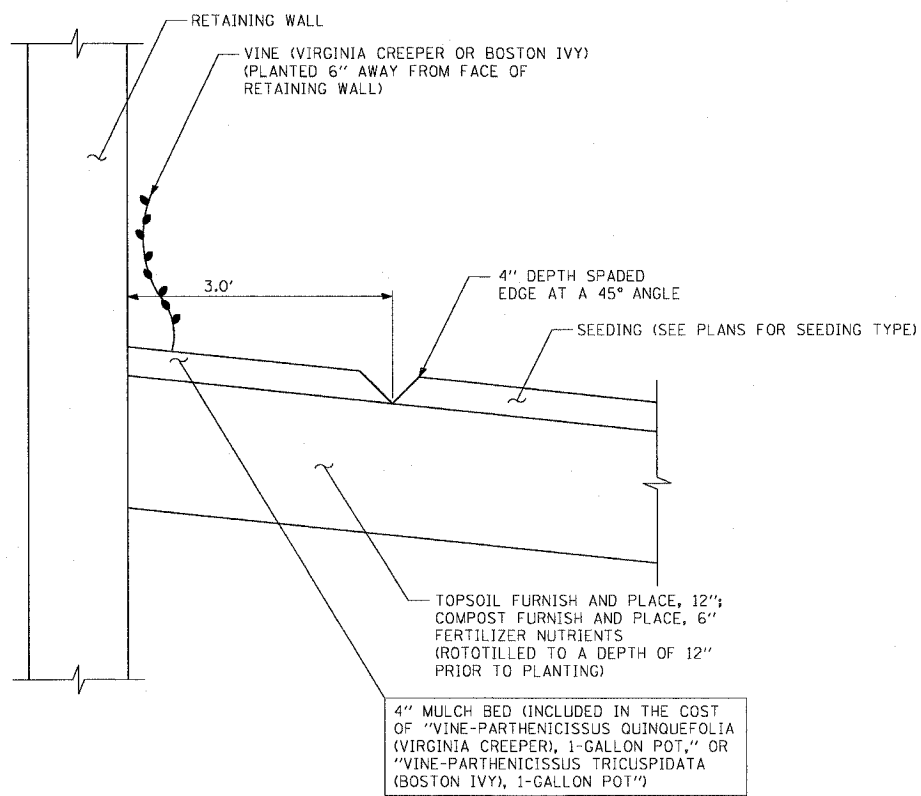

VINE PLANTING DETAIL

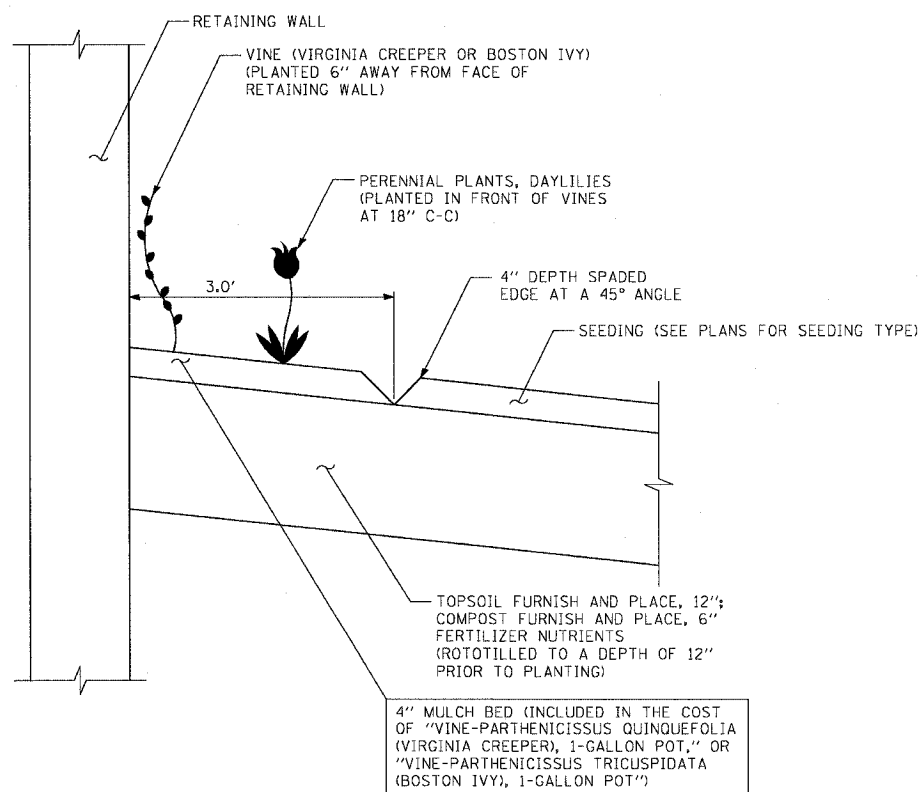

VINE AND DAYLILY PLANTING DETAIL

SCHEDULE OF LANDSCAPE ITEMS

PAY ITEM DESCRIPTION	COMMON NAME	SIZE	SPACING	UNIT	TOTAL
VINE - PARTHENOCISSUS QUINQUEFOLIA, 1- GALLON POT	VIRGINIA CREEPER	1-GALLON	SEE PLANS	EACH	931
VINE - PARTHENOCISSUS TRICUSPIDATA	BOSTON IVY	1-GALLON	SEE PLANS	EACH	201
PERENNIAL PLANTS, DAYLILIES	HAPPY RETURNS DAYLILY	1-GALLON	12" C-C"	UNITS	8.36

REVISIONS	
NAME	DATE







ILLINOIS DEPARTMENT OF TRANSPORTATION
F.A.I. 90/94 (DAN RYAN EXPRESSWAY)
GARFIELD BLVD TO 31ST STREET (NB LOCAL LANES)

LANDSCAPING NOTES AND DETAILS

SCALE: NONE DRAWN BY: PHP
DATE: June 9, 2006 CHECKED BY: RMG

F.A.I. RTE.	SECTION	COUNTY	TOTAL SHEETS	SHEET NO.
90/94	*	COOK	565	288
STA. 4474+50		TO STA. 4482+00		
FED. ROAD DIST. NO. 1		ILLINOIS FED. AID PROJECT		
62301		(2021-922 PT2 ETC 2324.6-1P) R-10		

LEGEND:

-  TOPSOIL FURNISH AND PLACE, 4"
SEEDING, CLASS 2A
EROSION CONTROL BLANKET
-  TOPSOIL FURNISH AND PLACE, 12"
COMPOST FURNISH AND PLACE, 6"
SEEDING, CLASS 2A
EROSION CONTROL BLANKET
-  TOPSOIL FURNISH AND PLACE, 12"
COMPOST FURNISH AND PLACE, 6"
SEEDING, CLASS 4 (MODIFIED)
SEEDING, CLASS 5A (MODIFIED)
EROSION CONTROL BLANKET
-  TOPSOIL FURNISH AND PLACE, 12"
COMPOST FURNISH AND PLACE, 6"
SEEDING, CLASS 4A (MODIFIED)
SEEDING, CLASS 5 (MODIFIED)
EROSION CONTROL BLANKET
-  PERENNIAL PLANTS, IVY OR SHRUBS
TOPSOIL FURNISH AND PLACE, 12"
COMPOST FURNISH AND PLACE, 6"
EROSION CONTROL BLANKET
-  VINE

NOTES:

1. THE DIMENSIONS SHOWN ON THE PLANS SHALL BE USED AS A GUIDE TO LAY OUT THE SPECIFIED RESTORATION AREAS.

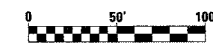
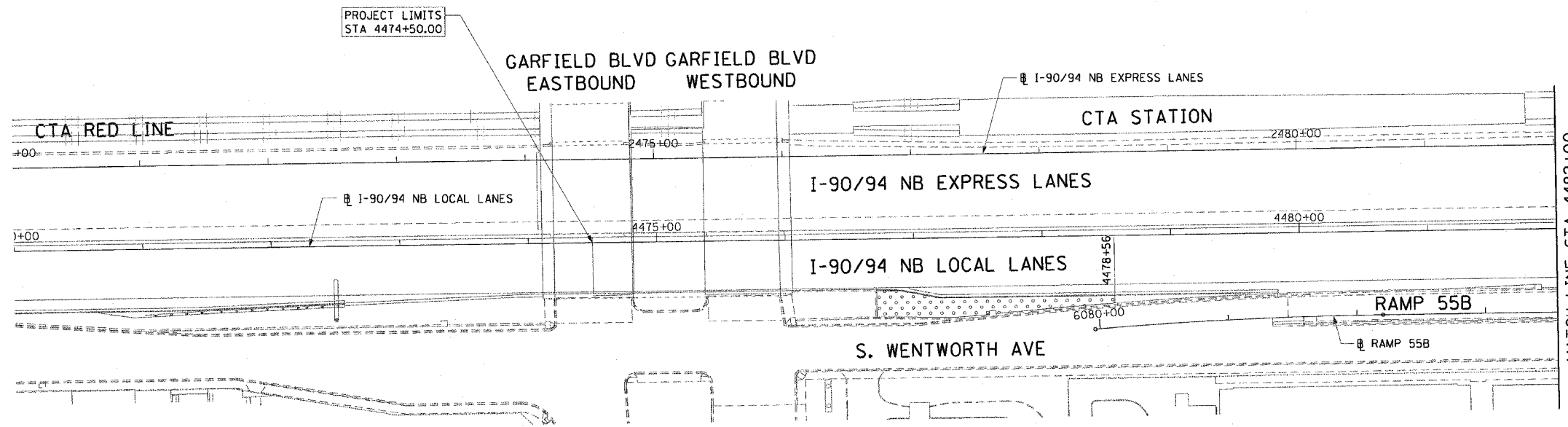

LA-01

CTE | AECOM

REVISIONS	
NAME	DATE

ILLINOIS DEPARTMENT OF TRANSPORTATION
F.A.I. 90/94 (DAN RYAN EXPRESSWAY)
GARFIELD BLVD TO 31ST STREET (NB LOCAL LANES)

LANDSCAPING PLANS
AND DETAILS







SCALE: 1"=50'
DATE: June 9, 2006

DRAWN BY: PHP
CHECKED BY: RMC

P:\P\04680\CM\NB-Chrs 18 & 19\5\FAC\18\Landscaping\LA01\0121.dwg 6/7/2006 12:27:13 PM

F.A.I. RTE.	SECTION	COUNTY	TOTAL SHEETS	SHEET NO.
90/94		COOK	565	289
STA. 4482+00	TO STA. 4506+00			
FED. ROAD DIST. NO. 1 ILLINOIS FED. AID PROJECT				
62301 • (2021-922 PT2 ETC 2324.6-IP) R-10				

LEGEND:

-  TOPSOIL FURNISH AND PLACE, 4" SEEDING, CLASS 2A EROSION CONTROL BLANKET
-  TOPSOIL FURNISH AND PLACE, 12" COMPOST FURNISH AND PLACE, 6" SEEDING, CLASS 2A EROSION CONTROL BLANKET
-  TOPSOIL FURNISH AND PLACE, 12" COMPOST FURNISH AND PLACE, 6" SEEDING, CLASS 4 (MODIFIED) SEEDING, CLASS 5A (MODIFIED) EROSION CONTROL BLANKET
-  TOPSOIL FURNISH AND PLACE, 12" COMPOST FURNISH AND PLACE, 6" SEEDING, CLASS 4A (MODIFIED) SEEDING, CLASS 5 (MODIFIED) EROSION CONTROL BLANKET
-  PERENNIAL PLANTS, IVY OR SHRUBS TOPSOIL FURNISH AND PLACE, 12" COMPOST FURNISH AND PLACE, 6" EROSION CONTROL BLANKET
-  VINE

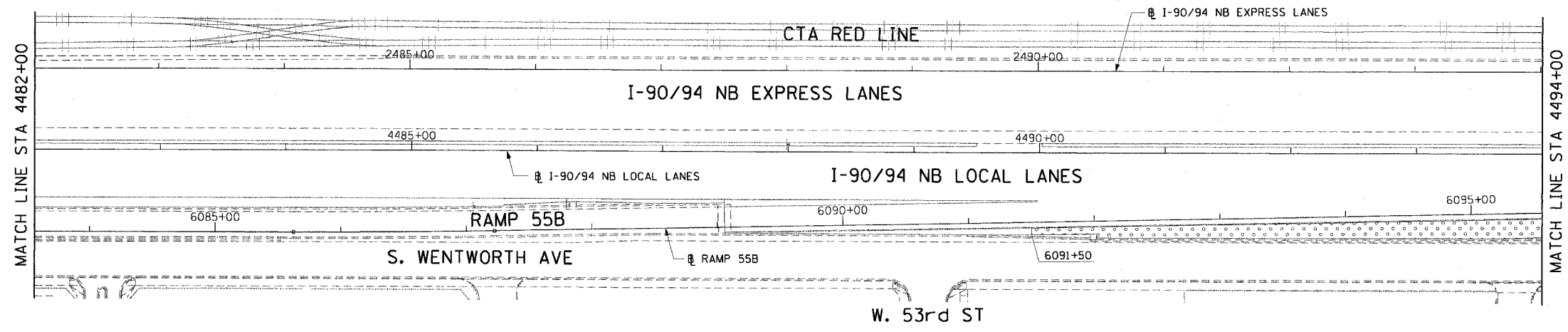

NOTES:

1. THE DIMENSIONS SHOWN ON THE PLANS SHALL BE USED AS A GUIDE TO LAY OUT THE SPECIFIED RESTORATION AREAS.

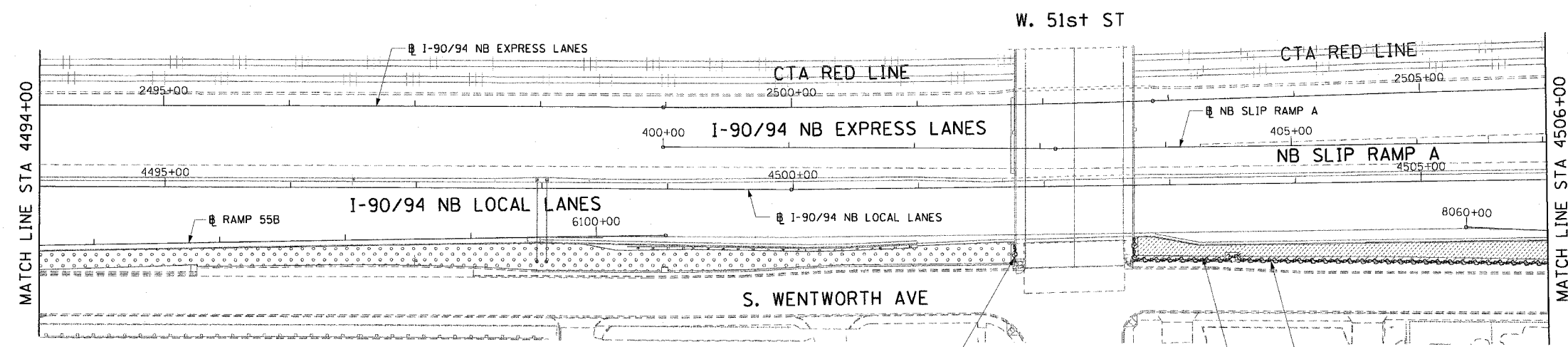

- 15 - BOSTON IVY (1' O.C. - ALONG BASE OF WALL/MULCH BED)
- 177 - VIRGINIA CREEPER (2' O.C. - ALONG BASE OF RETAINING WALL/MULCH BED)
- 354 - HAPPY RETURNS DAYLILY (1' O.C. - ALONG FRONT OF VINES/MULCH BED)

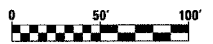

LA-02

REVISIONS	
NAME	DATE

ILLINOIS DEPARTMENT OF TRANSPORTATION
 F.A.I. 90/94 (DAN RYAN EXPRESSWAY)
 GARFIELD BLVD TO 31ST STREET (NB LOCAL LANES)

**LANDSCAPING PLANS
 AND DETAILS**

SCALE: 1"=50'
 DATE: June 9, 2006







DRAWN BY: PHP
 CHECKED BY: RMG

CTE | AECOM

P:\P40468\CH1\18-Ctr18 & 19\SM\CH18-Landscaping\LA02022.dwg 6/7/2006 12:27:24 PM

F.A.I. RTE.	SECTION	COUNTY	TOTAL SHEETS	SHEET NO.
90/94		COOK	565	290
STA. 4506+00		TO STA. 4529+00		
FED. ROAD DIST. NO. 1 ILLINOIS FED. AID PROJECT				
62301 • (2021-922 PT2 ETC 2324.6-IP) R-10				

LEGEND:

-  TOPSOIL FURNISH AND PLACE, 4" SEEDING, CLASS 2A EROSION CONTROL BLANKET
-  TOPSOIL FURNISH AND PLACE, 12" COMPOST FURNISH AND PLACE, 6" SEEDING, CLASS 2A EROSION CONTROL BLANKET
-  TOPSOIL FURNISH AND PLACE, 12" COMPOST FURNISH AND PLACE, 6" SEEDING, CLASS 4 (MODIFIED) SEEDING, CLASS 5A (MODIFIED) EROSION CONTROL BLANKET
-  TOPSOIL FURNISH AND PLACE, 12" COMPOST FURNISH AND PLACE, 6" SEEDING, CLASS 4A (MODIFIED) SEEDING, CLASS 5 (MODIFIED) EROSION CONTROL BLANKET
-  PERENNIAL PLANTS, IVY OR SHRUBS TOPSOIL FURNISH AND PLACE, 12" COMPOST FURNISH AND PLACE, 6" EROSION CONTROL BLANKET
-  VINE

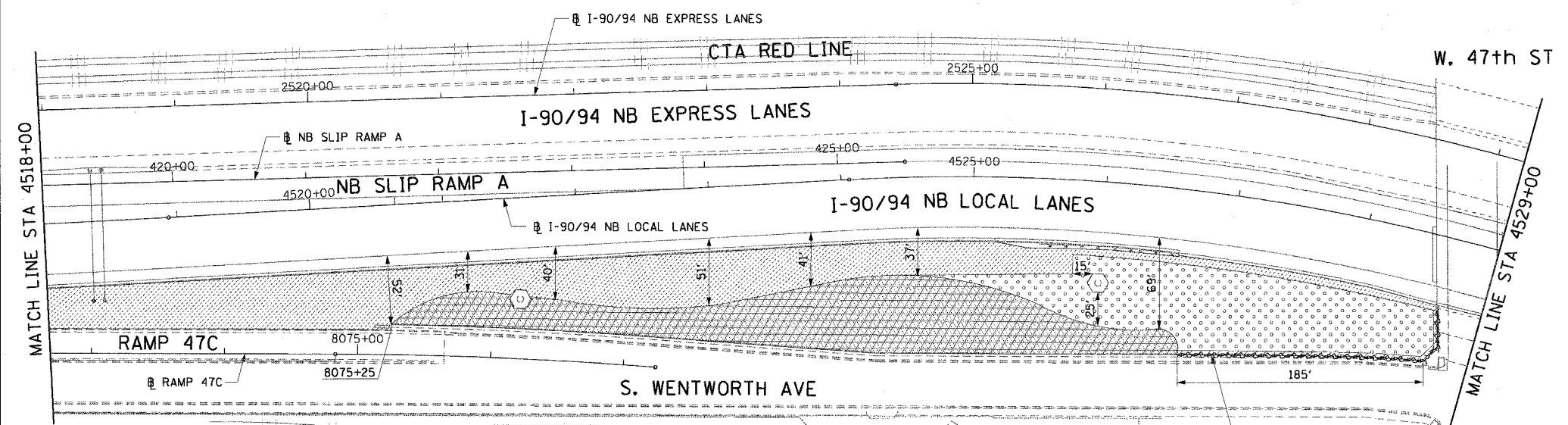
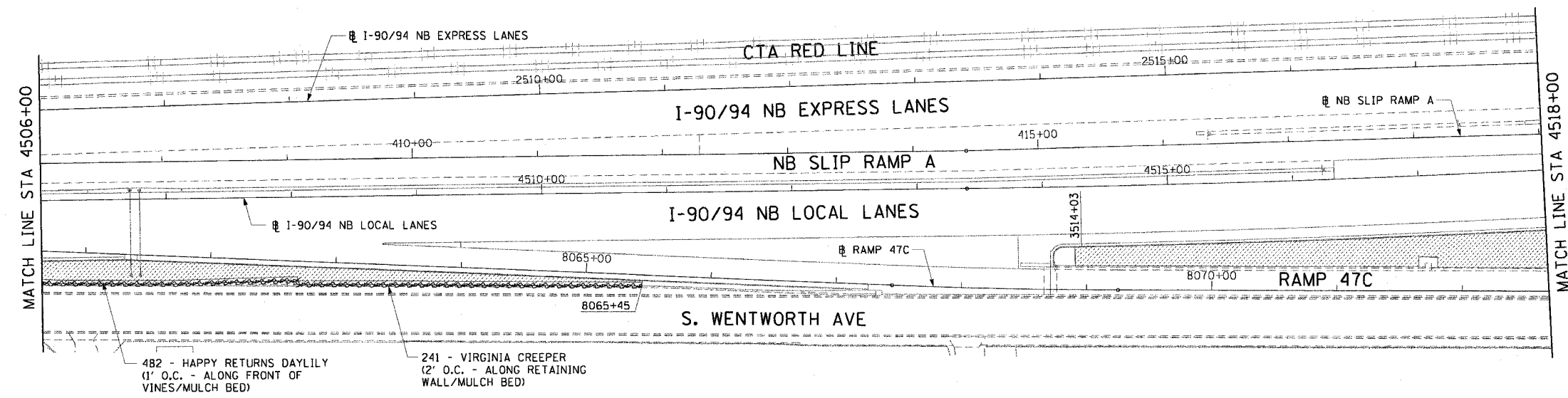

NOTES:

1. THE DIMENSIONS SHOWN ON THE PLANS SHALL BE USED AS A GUIDE TO LAY OUT THE SPECIFIED RESTORATION AREAS.

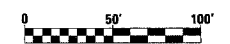

LA-03

REVISIONS	
NAME	DATE

ILLINOIS DEPARTMENT OF TRANSPORTATION
 F.A.I. 90/94 (DAN RYAN EXPRESSWAY)
 GARFIELD BLVD TO 31ST STREET (NB LOCAL LANES)

LANDSCAPING PLANS
 AND DETAILS

SCALE: 1"=50'
 DATE: June 9, 2006

DRAWN BY: PHP
 CHECKED BY: RMG

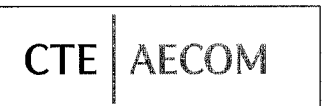

P:\940468\Civil\8-Civil\8-19-SIF\CTR-18\Landscaping\LA00323.rvt 6/11/2006 12:27:36 PM

F.A.I.	SECTION	COUNTY	TOTAL SHEETS	SHEET NO.
94/90		COOK	565	291
STA.	TO STA.			
FED. ROAD DIST. NO. ILLINOIS FED. AID PROJECT				
62301 (2021-922 PT2 ETC 2324.6-1P) R-10				

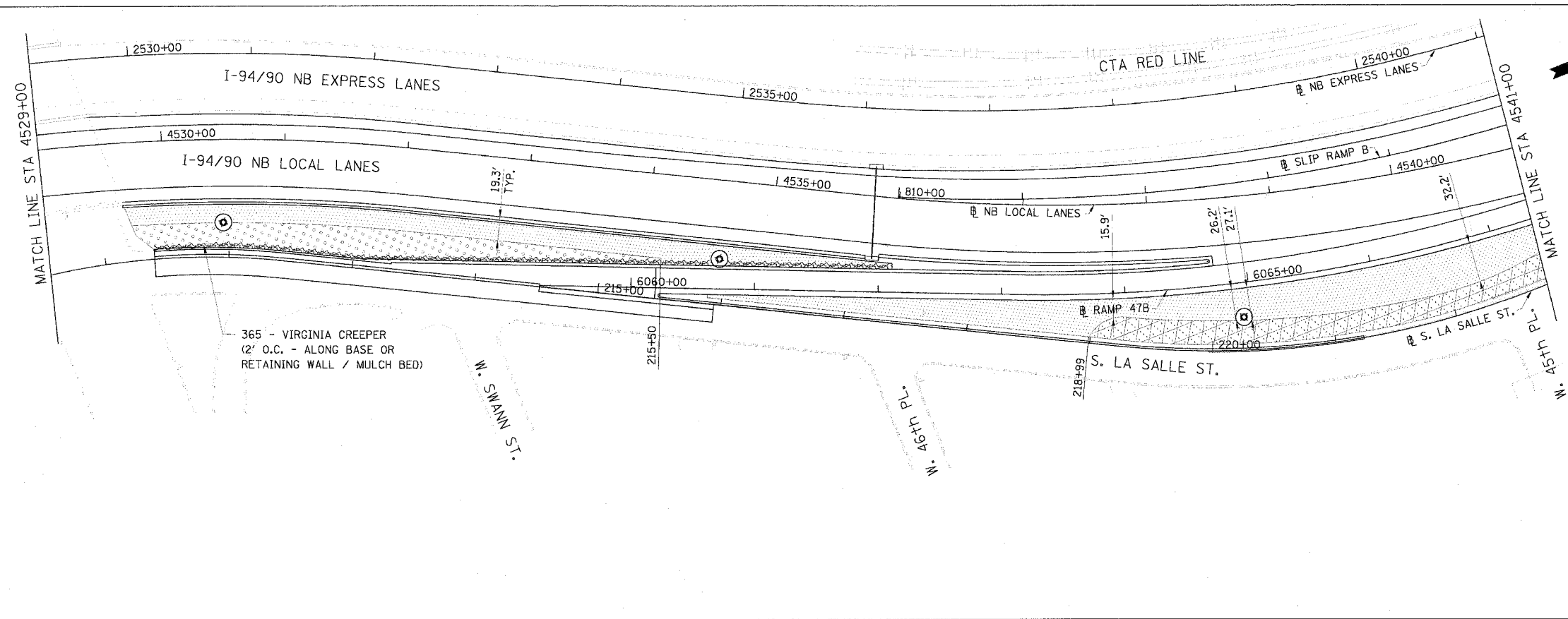

- LEGEND:
- TOPSOIL FURNISH AND PLACE, 4" SEEDING, CLASS 2A EROSION CONTROL BLANKET
 - TOPSOIL FURNISH AND PLACE, 12" COMPOST FURNISH AND PLACE, 6" SEEDING, CLASS 2A EROSION CONTROL BLANKET
 - TOPSOIL FURNISH AND PLACE, 12" COMPOST FURNISH AND PLACE, 6" SEEDING, CLASS 4 (MODIFIED) SEEDING, CLASS 5A (MODIFIED) EROSION CONTROL BLANKET
 - TOPSOIL FURNISH AND PLACE, 12" COMPOST FURNISH AND PLACE, 6" SEEDING, CLASS 4A (MODIFIED) SEEDING, CLASS 5 (MODIFIED) EROSION CONTROL BLANKET
 - PERENNIAL PLANTS, IVY OR SHRUBS TOPSOIL FURNISH AND PLACE, 12" COMPOST FURNISH AND PLACE, 6" EROSION CONTROL BLANKET
 - VINE

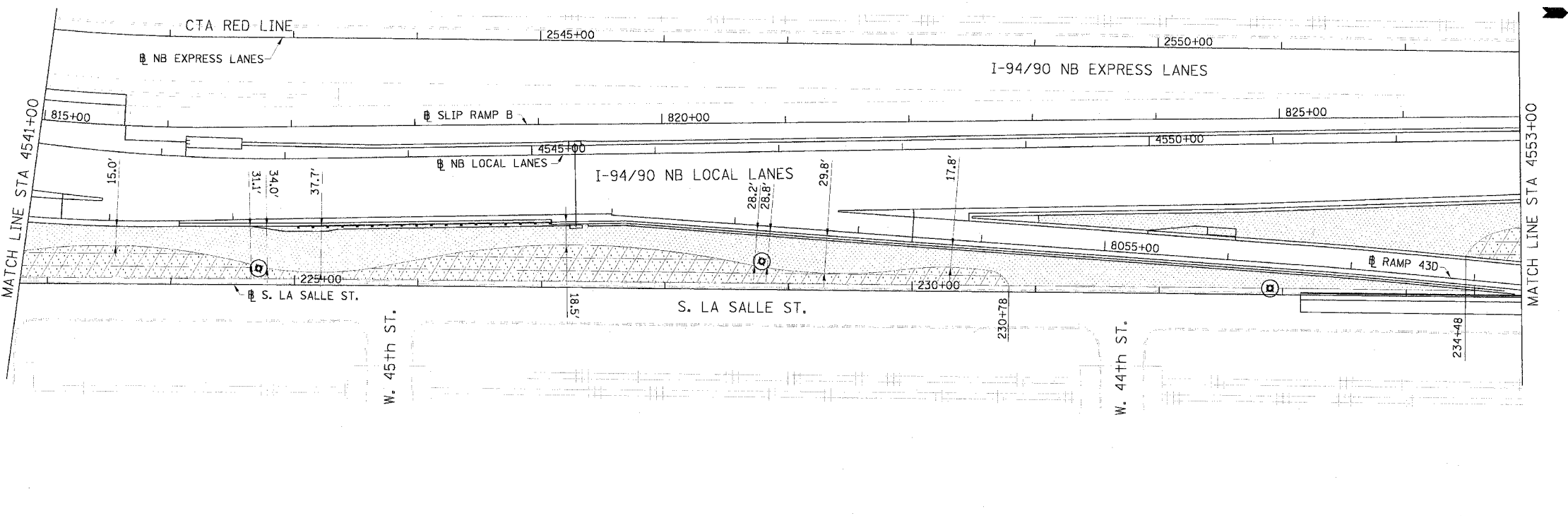

- LANDSCAPING NOTES:
1. THE CONTRACTOR SHALL TAKE ALL NECESSARY PRECAUTIONS FOR THE PROTECTION OF EXISTING PLANT MATERIAL THAT THE CONTRACT DOES NOT PROVIDE REMOVAL. THE PROTECTION OF EXISTING PLANT MATERIAL, AND THE REPAIR OR REPLACEMENT OF EXISTING PLANT MATERIAL DAMAGED BY THE CONTRACTOR SHALL BE DONE IN ACCORDANCE WITH THE REQUIREMENTS OF SECTION 201 OF THE STANDARD SPECIFICATIONS.
 2. THE SEEDING DATES FOR BARE EARTH SEEDING OF MIXTURE CLASS 2A SHALL BE FROM APRIL 1 TO JUNE 1 AND FROM AUGUST 15 TO SEPTEMBER 30. ALL SEEDING NOT SOWN ACCORDING TO THE SPECIFIED SEASONAL DATES SHALL REQUIRE PRIOR WRITTEN APPROVAL FROM THE ENGINEER. FAILURE TO SECURE SUCH APPROVAL SHALL RESULT IN THE REJECTION OF THE SEEDING AND REPLACEMENT BY THE CONTRACTOR AT HIS/HER EXPENSE.
 3. ALL SEEDING, CLASS 2A AREAS SHALL HAVE NITROGEN, PHOSPHORUS, AND POTASSIUM FERTILIZER NUTRIENTS APPLIED AT A RATE OF 90 LBS/ACRE EACH.
 4. THE DIMENSIONS SHOWN ON THE PLANS SHALL BE USED AS A GUIDE TO LAY OUT THE SPECIFIED RESTORATION AREAS.

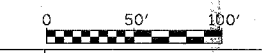

LAN-04

DLK
Civic Design
The Fine Arts Building
410 South Michigan Avenue
Chicago, Illinois 60605
312.322.0911 fax 312.322.5324

REVISIONS	
NAME	DATE

ILLINOIS DEPARTMENT OF TRANSPORTATION
F.A.I. 94/90 (DAN RYAN EXPRESSWAY)
GARFIELD BLVD TO 31ST STREET (NB LOCAL LANES)

LANDSCAPING PLAN

SCALE: 1"=50'
DATE: June 9, 2006

DRAWN BY: RPS
CHECKED BY: RCH

F.A.I.	SECTION	COUNTY	TOTAL SHEETS	SHEET NO.
94/90		COOK	565	292
STA.	TO STA.			
FED. ROAD DIST. NO.	ILLINOIS	FED. AID PROJECT		
62301	*I2021-922 PT2 ETC 2324.6-1P) R-10			

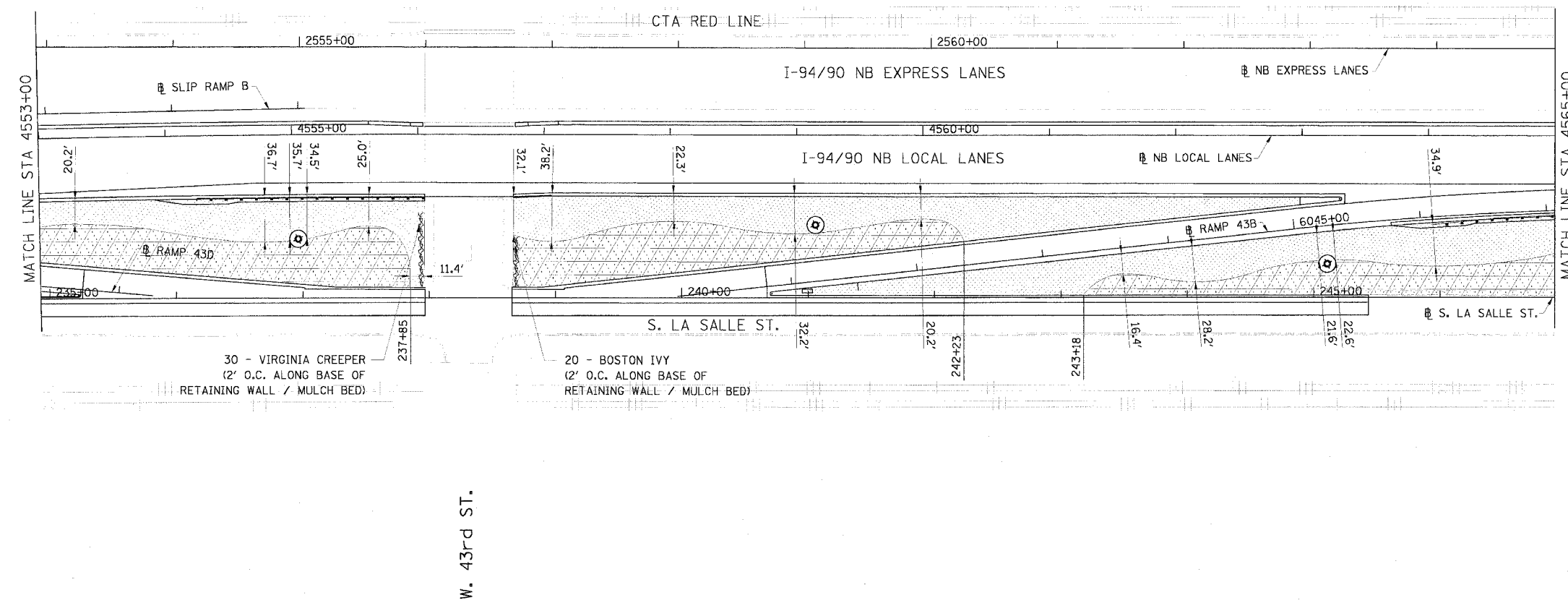

- LEGEND:
- TOPSOIL FURNISH AND PLACE, 4" SEEDING, CLASS 2A EROSION CONTROL BLANKET
 - TOPSOIL FURNISH AND PLACE, 12" COMPOST FURNISH AND PLACE, 6" SEEDING, CLASS 2A EROSION CONTROL BLANKET
 - TOPSOIL FURNISH AND PLACE, 12" COMPOST FURNISH AND PLACE, 6" SEEDING, CLASS 4 (MODIFIED) SEEDING, CLASS 5A (MODIFIED) EROSION CONTROL BLANKET
 - TOPSOIL FURNISH AND PLACE, 12" COMPOST FURNISH AND PLACE, 6" SEEDING, CLASS 4A (MODIFIED) SEEDING, CLASS 5 (MODIFIED) EROSION CONTROL BLANKET
 - PERENNIAL PLANTS, IVY OR SHRUBS TOPSOIL FURNISH AND PLACE, 12" COMPOST FURNISH AND PLACE, 6" EROSION CONTROL BLANKET
 - VINE

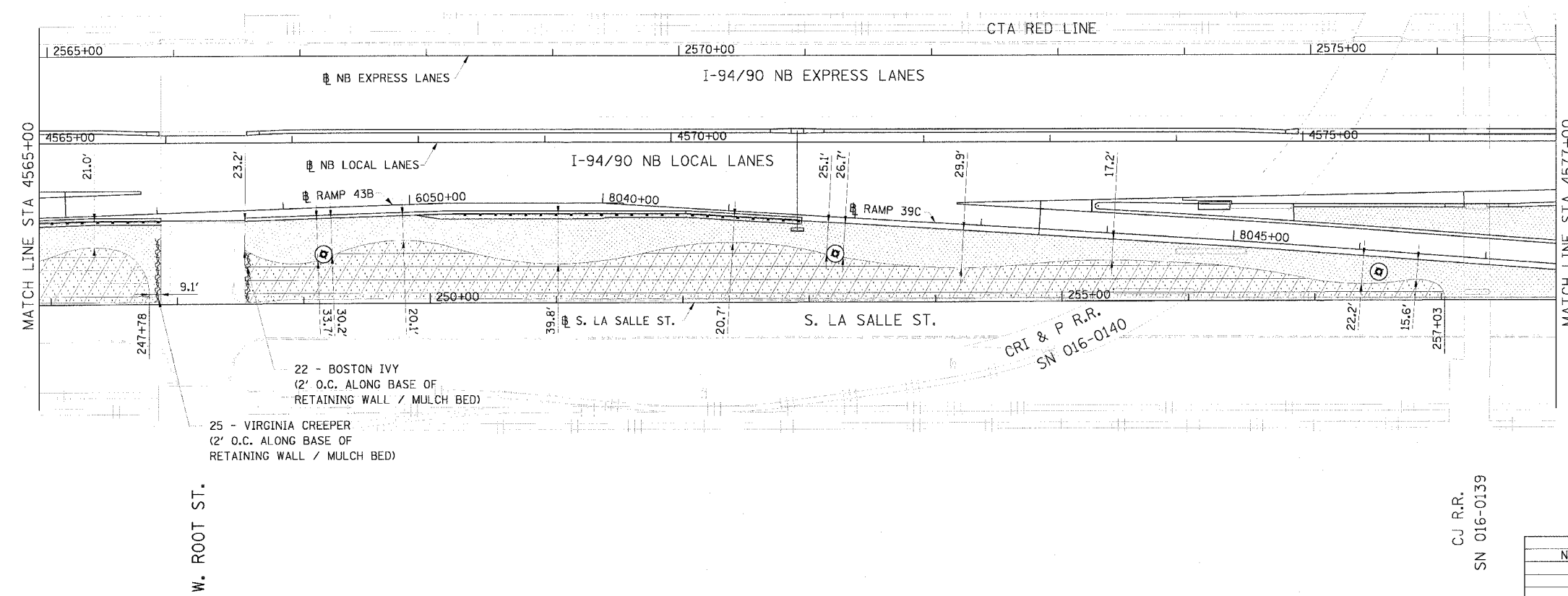

- LANDSCAPING NOTES:
1. THE CONTRACTOR SHALL TAKE ALL NECESSARY PRECAUTIONS FOR THE PROTECTION OF EXISTING PLANT MATERIAL THAT THE CONTRACT DOES NOT PROVIDE REMOVAL. THE PROTECTION OF EXISTING PLANT MATERIAL, AND THE REPAIR OR REPLACEMENT OF EXISTING PLANT MATERIAL DAMAGED BY THE CONTRACTOR SHALL BE DONE IN ACCORDANCE WITH THE REQUIREMENTS OF SECTION 201 OF THE STANDARD SPECIFICATIONS.
 2. THE SEEDING DATES FOR BARE EARTH SEEDING OF MIXTURE CLASS 2A SHALL BE FROM APRIL 1 TO JUNE 1 AND FROM AUGUST 15 TO SEPTEMBER 30. ALL SEEDING NOT SOWN ACCORDING TO THE SPECIFIED SEASONAL DATES SHALL REQUIRE PRIOR WRITTEN APPROVAL FROM THE ENGINEER. FAILURE TO SECURE SUCH APPROVAL SHALL RESULT IN THE REJECTION OF THE SEEDING AND REPLACEMENT BY THE CONTRACTOR AT HIS/HER EXPENSE.
 3. ALL SEEDING, CLASS 2A AREAS SHALL HAVE NITROGEN, PHOSPHORUS, AND POTASSIUM FERTILIZER NUTRIENTS APPLIED AT A RATE OF 90 LBS/ACRE EACH.
 4. THE DIMENSIONS SHOWN ON THE PLANS SHALL BE USED AS A GUIDE TO LAY OUT THE SPECIFIED RESTORATION AREAS.

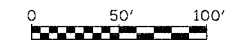

REVISIONS NAME	DATE

ILLINOIS DEPARTMENT OF TRANSPORTATION
 F.A.I. 94/90 (DAN RYAN EXPRESSWAY)
 GARFIELD BLVD TO 31ST STREET (NB LOCAL LANES)

LANDSCAPING PLAN

SCALE: 1"=50'
 DATE: June 9, 2006

DRAWN BY: RPS
 CHECKED BY: RCH

DLK
 Civic Design

The Fine Arts Building
 410 South Michigan Avenue
 Chicago, Illinois 60605
 312.322.0911 fax 312.322.5324

CJ R.R.
 SN 016-0139

LAN-05

A:\2006\94-90\94-90-016-0139.dwg

F.A.I.	SECTION	COUNTY	TOTAL SHEETS	SHEET NO.
94/90		COOK	565	293
STA.	TO STA.			
FED. ROAD DIST. NO.	ILLINOIS	FED. AID PROJECT		
62301	*(2021-922 PT2 ETC 2324.6-1P) R-10			

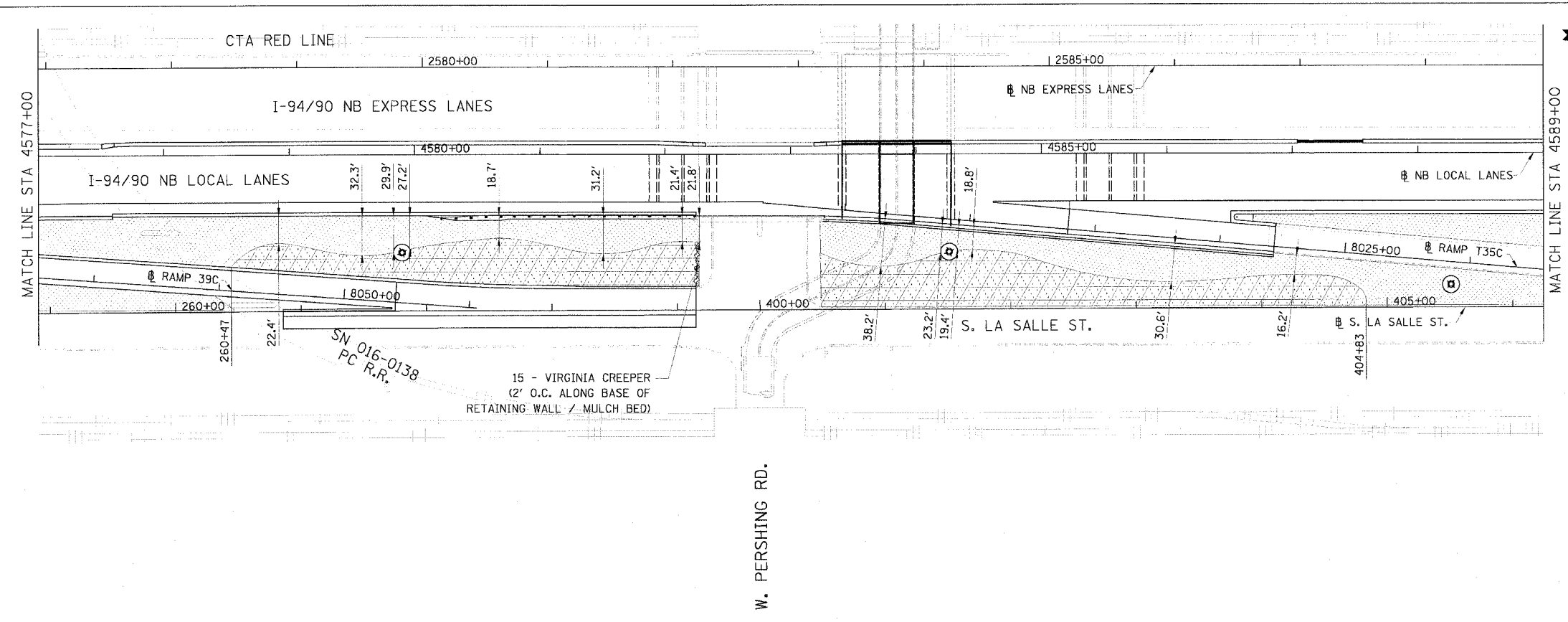

- LEGEND:
- TOPSOIL FURNISH AND PLACE, 4" SEEDING, CLASS 2A EROSION CONTROL BLANKET
 - TOPSOIL FURNISH AND PLACE, 12" COMPOST FURNISH AND PLACE, 6" SEEDING, CLASS 2A EROSION CONTROL BLANKET
 - TOPSOIL FURNISH AND PLACE, 12" COMPOST FURNISH AND PLACE, 6" SEEDING, CLASS 4 (MODIFIED) SEEDING, CLASS 5A (MODIFIED) EROSION CONTROL BLANKET
 - TOPSOIL FURNISH AND PLACE, 12" COMPOST FURNISH AND PLACE, 6" SEEDING, CLASS 4A (MODIFIED) SEEDING, CLASS 5 (MODIFIED) EROSION CONTROL BLANKET
 - PERENNIAL PLANTS, IVY OR SHRUBS TOPSOIL FURNISH AND PLACE, 12" COMPOST FURNISH AND PLACE, 6" SEEDING, CLASS 4 (MODIFIED) EROSION CONTROL BLANKET
 - VINE

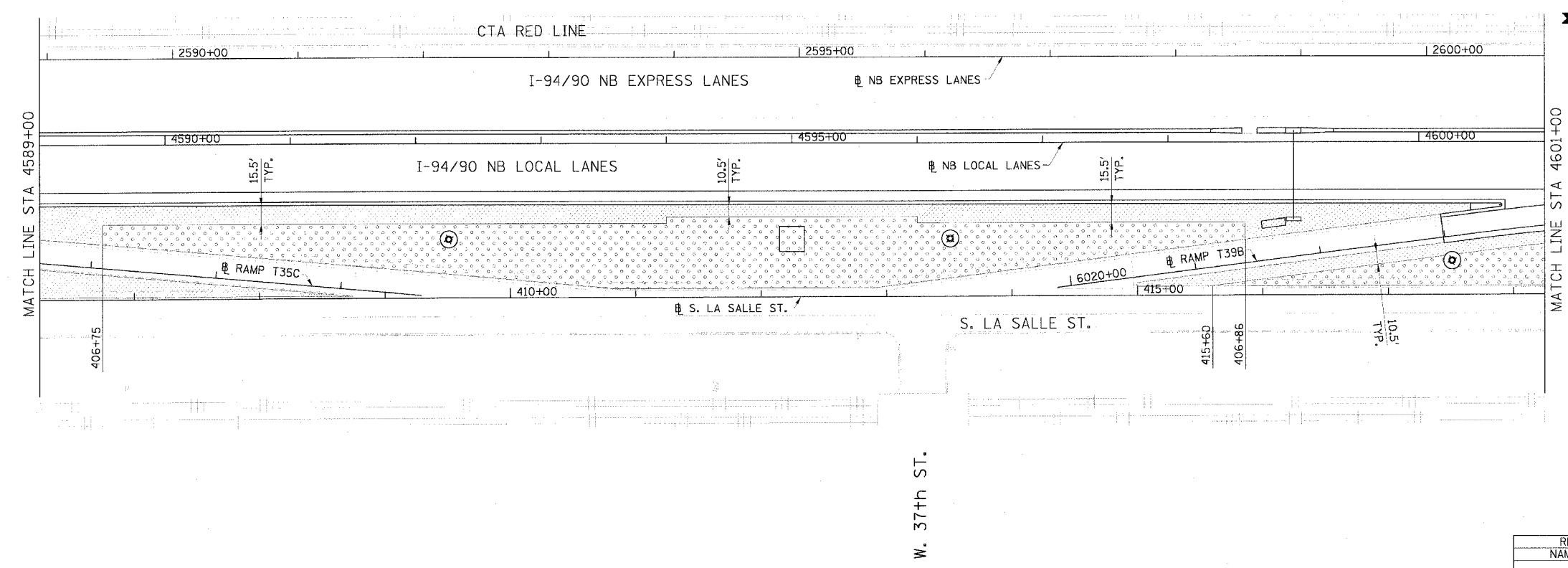

- LANDSCAPING NOTES:
1. THE CONTRACTOR SHALL TAKE ALL NECESSARY PRECAUTIONS FOR THE PROTECTION OF EXISTING PLANT MATERIAL THAT THE CONTRACT DOES NOT PROVIDE REMOVAL. THE PROTECTION OF EXISTING PLANT MATERIAL, AND THE REPAIR OR REPLACEMENT OF EXISTING PLANT MATERIAL DAMAGED BY THE CONTRACTOR SHALL BE DONE IN ACCORDANCE WITH THE REQUIREMENTS OF SECTION 201 OF THE STANDARD SPECIFICATIONS.
 2. THE SEEDING DATES FOR BARE EARTH SEEDING OF MIXTURE CLASS 2A SHALL BE FROM APRIL 1 TO JUNE 1 AND FROM AUGUST 15 TO SEPTEMBER 30. ALL SEEDING NOT SOWN ACCORDING TO THE SPECIFIED SEASONAL DATES SHALL REQUIRE PRIOR WRITTEN APPROVAL FROM THE ENGINEER. FAILURE TO SECURE SUCH APPROVAL SHALL RESULT IN THE REJECTION OF THE SEEDING AND REPLACEMENT BY THE CONTRACTOR AT HIS/HER EXPENSE.
 3. ALL SEEDING, CLASS 2A AREAS SHALL HAVE NITROGEN, PHOSPHORUS, AND POTASSIUM FERTILIZER NUTRIENTS APPLIED AT A RATE OF 90 LBS/ACRE EACH.
 4. THE DIMENSIONS SHOWN ON THE PLANS SHALL BE USED AS A GUIDE TO LAY OUT THE SPECIFIED RESTORATION AREAS.

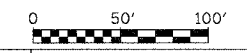

LAN-06

REVISIONS	
NAME	DATE

ILLINOIS DEPARTMENT OF TRANSPORTATION
 F.A.I. 94/90 (DAN RYAN EXPRESSWAY)
 GARFIELD BLVD TO 31ST STREET (NB LOCAL LANES)

LANDSCAPING PLAN

SCALE: 1"=50'
 DATE: June 9, 2006

DRAWN BY: RPS
 CHECKED BY: RCH

DLK
 Civic Design

The Fine Arts Building
 410 South Michigan Avenue
 Chicago, Illinois 60605
 312.322.0911 fax 312.322.5324

F.A.I.	SECTION	COUNTY	TOTAL SHEETS	SHEET NO.
94/90	*	COOK	565	294
STA.	TO STA.			
FED. ROAD DIST. NO.	ILLINOIS	FED. AID PROJECT		
62301	*(2021-922 PT2 ETC 2324.6-1P) R-10			

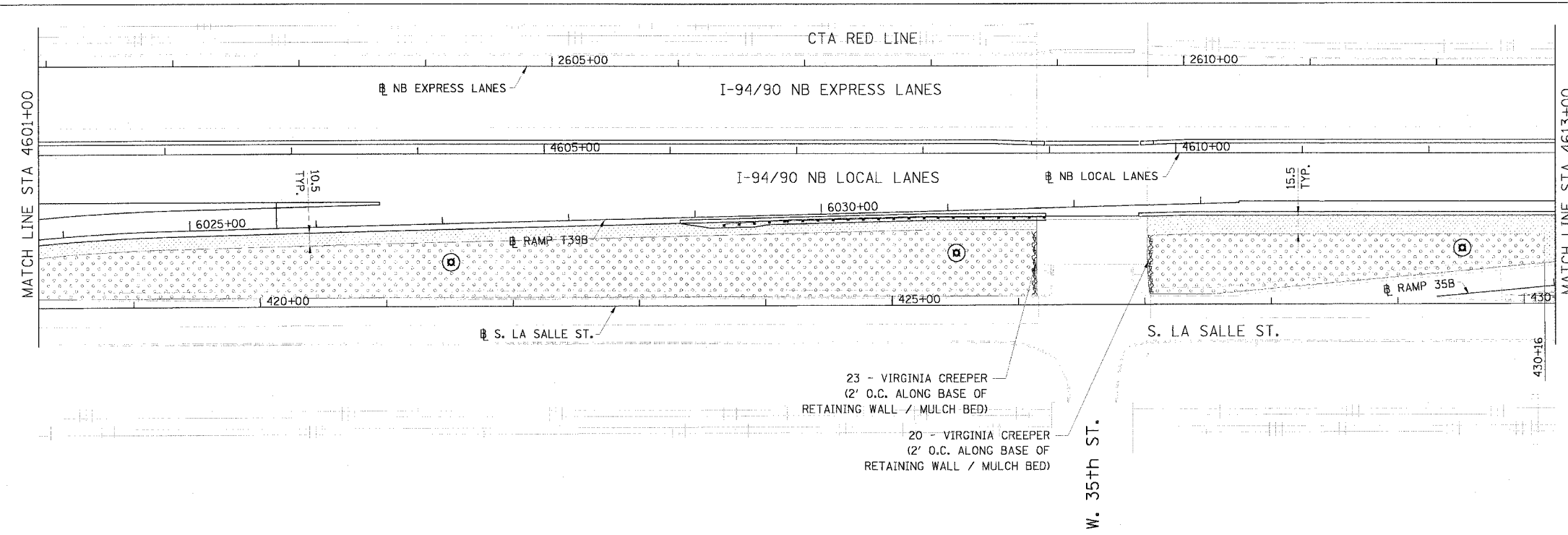

- LEGEND:**
- TOPSOIL FURNISH AND PLACE, 4" SEEDING, CLASS 2A EROSION CONTROL BLANKET
 - TOPSOIL FURNISH AND PLACE, 12" COMPOST FURNISH AND PLACE, 6" SEEDING, CLASS 2A EROSION CONTROL BLANKET
 - TOPSOIL FURNISH AND PLACE, 12" COMPOST FURNISH AND PLACE, 6" SEEDING, CLASS 4 (MODIFIED) SEEDING, CLASS 5A (MODIFIED) EROSION CONTROL BLANKET
 - TOPSOIL FURNISH AND PLACE, 12" COMPOST FURNISH AND PLACE, 6" SEEDING, CLASS 4A (MODIFIED) SEEDING, CLASS 5 (MODIFIED) EROSION CONTROL BLANKET
 - PERENNIAL PLANTS, IVY OR SHRUBS TOPSOIL FURNISH AND PLACE, 12" COMPOST FURNISH AND PLACE, 6" EROSION CONTROL BLANKET
 - VINE

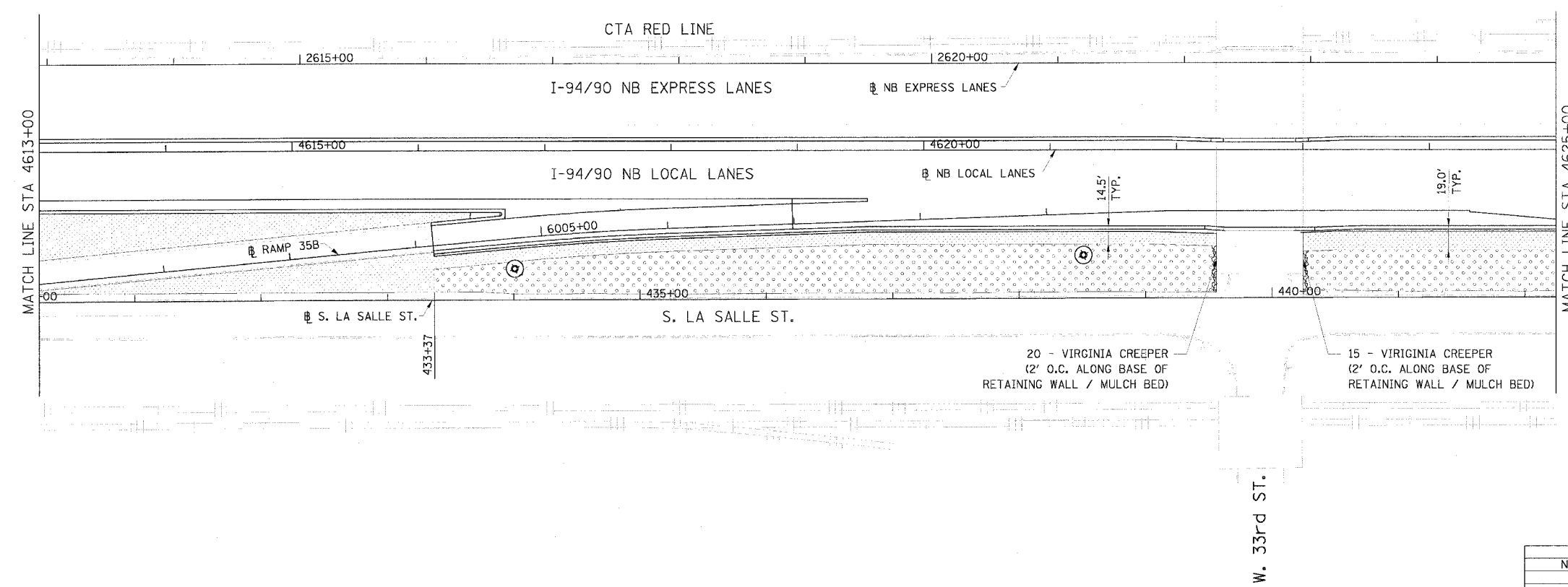

- LANDSCAPING NOTES:**
- THE CONTRACTOR SHALL TAKE ALL NECESSARY PRECAUTIONS FOR THE PROTECTION OF EXISTING PLANT MATERIAL THAT THE CONTRACT DOES NOT PROVIDE REMOVAL. THE PROTECTION OF EXISTING PLANT MATERIAL, AND THE REPAIR OR REPLACEMENT OF EXISTING PLANT MATERIAL DAMAGED BY THE CONTRACTOR SHALL BE DONE IN ACCORDANCE WITH THE REQUIREMENTS OF SECTION 201 OF THE STANDARD SPECIFICATIONS.
 - THE SEEDING DATES FOR BARE EARTH SEEDING OF MIXTURE CLASS 2A SHALL BE FROM APRIL 1 TO JUNE 1 AND FROM AUGUST 15 TO SEPTEMBER 30. ALL SEEDING NOT SOWN ACCORDING TO THE SPECIFIED SEASONAL DATES SHALL REQUIRE PRIOR WRITTEN APPROVAL FROM THE ENGINEER. FAILURE TO SECURE SUCH APPROVAL SHALL RESULT IN THE REJECTION OF THE SEEDING AND REPLACEMENT BY THE CONTRACTOR AT HIS/HER EXPENSE.
 - ALL SEEDING, CLASS 2A AREAS SHALL HAVE NITROGEN, PHOSPHORUS, AND POTASSIUM FERTILIZER NUTRIENTS APPLIED AT A RATE OF 90 LBS/ACRE EACH.
 - THE DIMENSIONS SHOWN ON THE PLANS SHALL BE USED AS A GUIDE TO LAY OUT THE SPECIFIED RESTORATION AREAS.

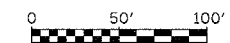

REVISIONS	
NAME	DATE

ILLINOIS DEPARTMENT OF TRANSPORTATION
 F.A.I. 94/90 (DAN RYAN EXPRESSWAY)
 GARFIELD BLVD TO 31ST STREET (NB LOCAL LANES)

LANDSCAPING PLAN

SCALE: 1"=50'
 DATE: June 9, 2006

DRAWN BY: RPS
 CHECKED BY: RCH

DLK
 Civic Design

The Fine Arts Building
 410 South Michigan Avenue
 Chicago, Illinois 60605
 312.322.0911 fax 312.322.5324

6/9/2006 Dan Ryan Expressway Construction Engineering Associates, Inc.

F.A.I.	SECTION	COUNTY	TOTAL SHEET NO.
94/90		COOK	565 295
STA.	TO STA.		
FED. ROAD DIST. NO.	ILLINOIS	FED. AID PROJECT	
62301	*2021-922 PT2 ETC 2324.6-1P1 R-10		

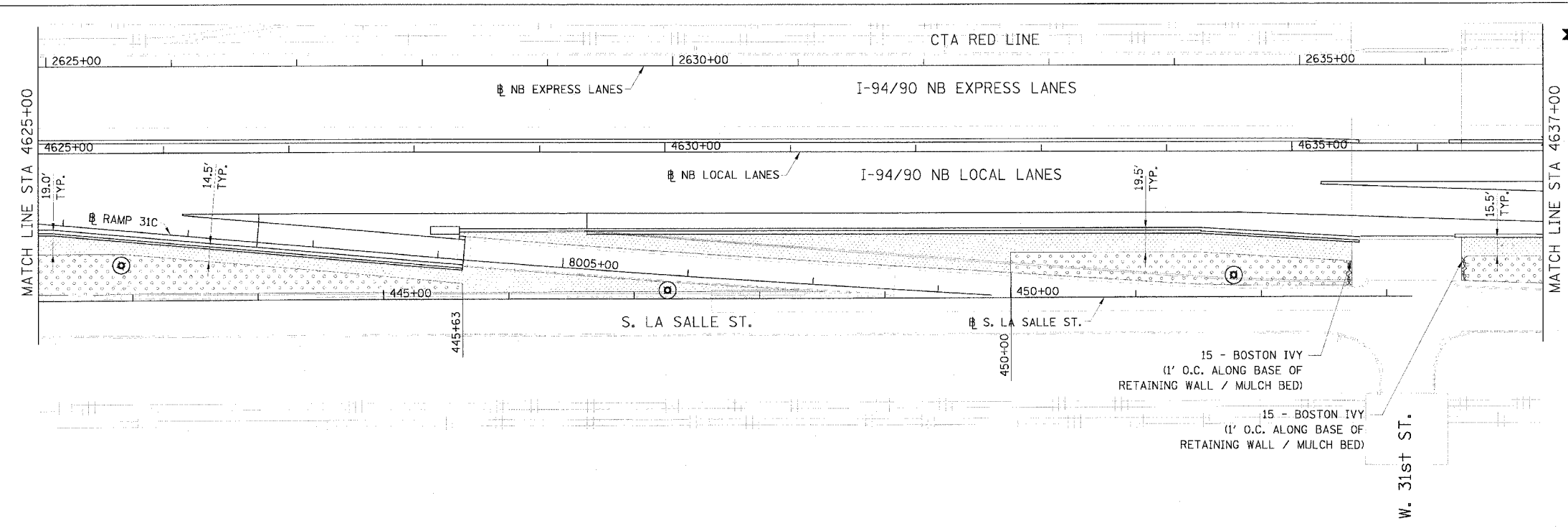

- LEGEND:**
- TOPSOIL FURNISH AND PLACE, 4" SEEDING, CLASS 2A EROSION CONTROL BLANKET
 - TOPSOIL FURNISH AND PLACE, 12" COMPOST FURNISH AND PLACE, 6" SEEDING, CLASS 2A EROSION CONTROL BLANKET
 - TOPSOIL FURNISH AND PLACE, 12" COMPOST FURNISH AND PLACE, 6" SEEDING, CLASS 4 (MODIFIED) SEEDING, CLASS 5A (MODIFIED) EROSION CONTROL BLANKET
 - TOPSOIL FURNISH AND PLACE, 12" COMPOST FURNISH AND PLACE, 6" SEEDING, CLASS 4A (MODIFIED) SEEDING, CLASS 5 (MODIFIED) EROSION CONTROL BLANKET
 - PERENNIAL PLANTS, IVY OR SHRUBS TOPSOIL FURNISH AND PLACE, 12" COMPOST FURNISH AND PLACE, 6" EROSION CONTROL BLANKET
 - VINE

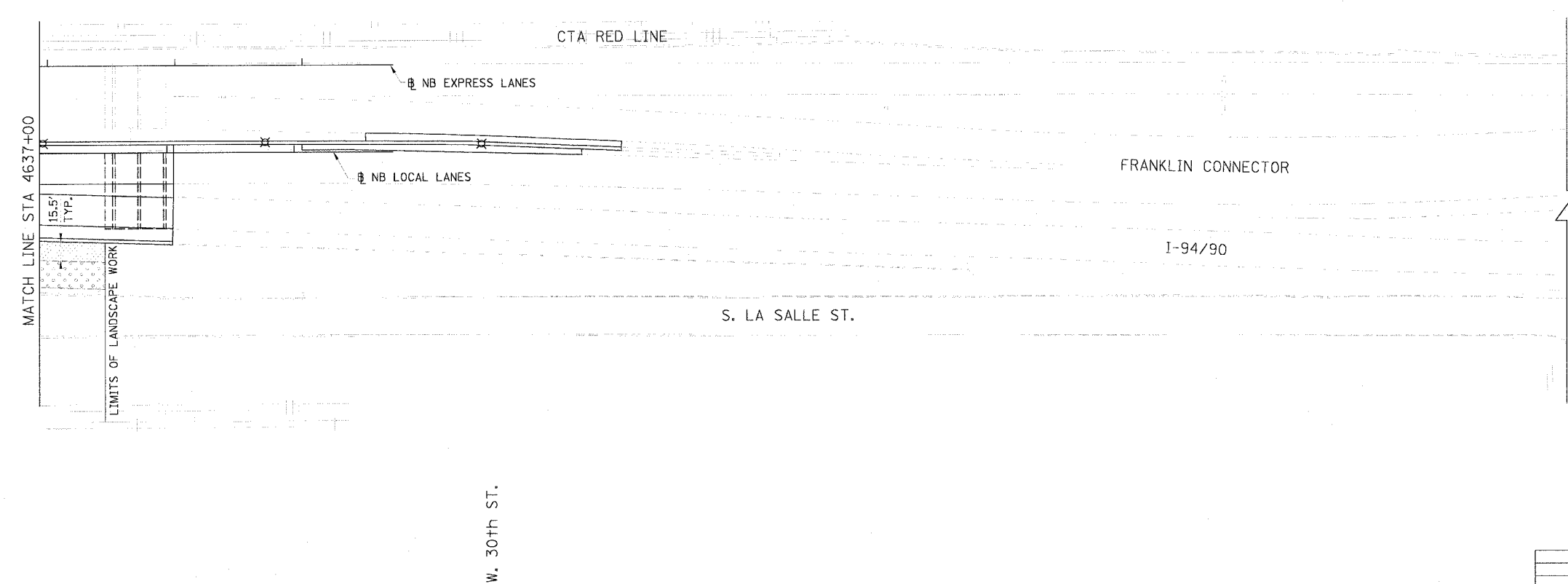

- LANDSCAPING NOTES:**
- THE CONTRACTOR SHALL TAKE ALL NECESSARY PRECAUTIONS FOR THE PROTECTION OF EXISTING PLANT MATERIAL THAT THE CONTRACT DOES NOT PROVIDE REMOVAL. THE PROTECTION OF EXISTING PLANT MATERIAL, AND THE REPAIR OR REPLACEMENT OF EXISTING PLANT MATERIAL DAMAGED BY THE CONTRACTOR SHALL BE DONE IN ACCORDANCE WITH THE REQUIREMENTS OF SECTION 201 OF THE STANDARD SPECIFICATIONS.
 - THE SEEDING DATES FOR BARE EARTH SEEDING OF MIXTURE CLASS 2A SHALL BE FROM APRIL 1 TO JUNE 1 AND FROM AUGUST 15 TO SEPTEMBER 30. ALL SEEDING NOT SOWN ACCORDING TO THE SPECIFIED SEASONAL DATES SHALL REQUIRE PRIOR WRITTEN APPROVAL FROM THE ENGINEER. FAILURE TO SECURE SUCH APPROVAL SHALL RESULT IN THE REJECTION OF THE SEEDING AND REPLACEMENT BY THE CONTRACTOR AT HIS/HER EXPENSE.
 - ALL SEEDING, CLASS 2A AREAS SHALL HAVE NITROGEN, PHOSPHORUS, AND POTASSIUM FERTILIZER NUTRIENTS APPLIED AT A RATE OF 90 LBS/ACRE EACH.
 - THE DIMENSIONS SHOWN ON THE PLANS SHALL BE USED AS A GUIDE TO LAY OUT THE SPECIFIED RESTORATION AREAS.

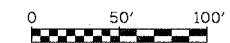

LAN-08

REVISIONS	
NAME	DATE

ILLINOIS DEPARTMENT OF TRANSPORTATION
 F.A.I. 94/90 (DAN RYAN EXPRESSWAY)
 GARFIELD BLVD TO 31ST STREET (NB LOCAL LANES)

LANDSCAPING PLAN

SCALE: 1"=50'
 DATE: June 9, 2006

DRAWN BY: RPS
 CHECKED BY: RCH

DLK
 Civic Design

The Fine Arts Building
 410 South Michigan Avenue
 Chicago, Illinois 60605
 312.322.0911 fax 312.322.5324

F.A.I. RTE.	SECTION	COUNTY	TOTAL SHEETS	SHEET NO.
90/94	*	COOK	565	298
STA. 1494+50.00 TO STA. 1506+50.00				
FED. ROAD DIST. NO. 1 ILLINOIS		FED. AID PROJECT		
62301		* (2021-922 PT2 ETC 2324.6-1P) R-10		

NOTES:

- SEE DRAWINGS EI-100 AND EI-101 FOR ELECTRICAL SYMBOLS AND ABBREVIATIONS.
- SEE DRAWINGS EI-102, EI-103, AND EI-104 FOR TYPICAL HANDHOLE INSTALLATION DETAILS.
- THE CONTRACTOR SHALL LOCATE THE EXISTING CONDUIT STUB-OUT INSTALLED IN IDOT CONTRACT NO. 62300 AND CONNECT THE PROPOSED CONDUIT.
- EXTEND CONDUIT STUB-OUT 2' BEYOND THE SIGN STRUCTURE FOUNDATION. CAP FOR FUTURE USE.
- PROVIDE A 3" RGS CONDUIT TO EDGE OF LANE PAVEMENT FOR DETECTOR LOOP WIRING. DETECTOR LOOPS WILL BE SAW CUT IN LOCAL LANES IN CONTRACT 62583. COORDINATE EXACT CONDUIT LOCATION WITH THE CONTRACT 62583.
- PROVIDE A SLEEVE FOR A 3" CNC CONDUIT INSTALLED IN CONTRACT 62583.
- UNLESS NOTED OTHERWISE, ALL ITEMS AND WORK SHOWN IN HEAVY LINE WEIGHT ON THIS DRAWING ARE PROPOSED NEW ITEMS AND WORK.

P:\p465\elec\90-94\90-94-922\90-94-922-10.dwg

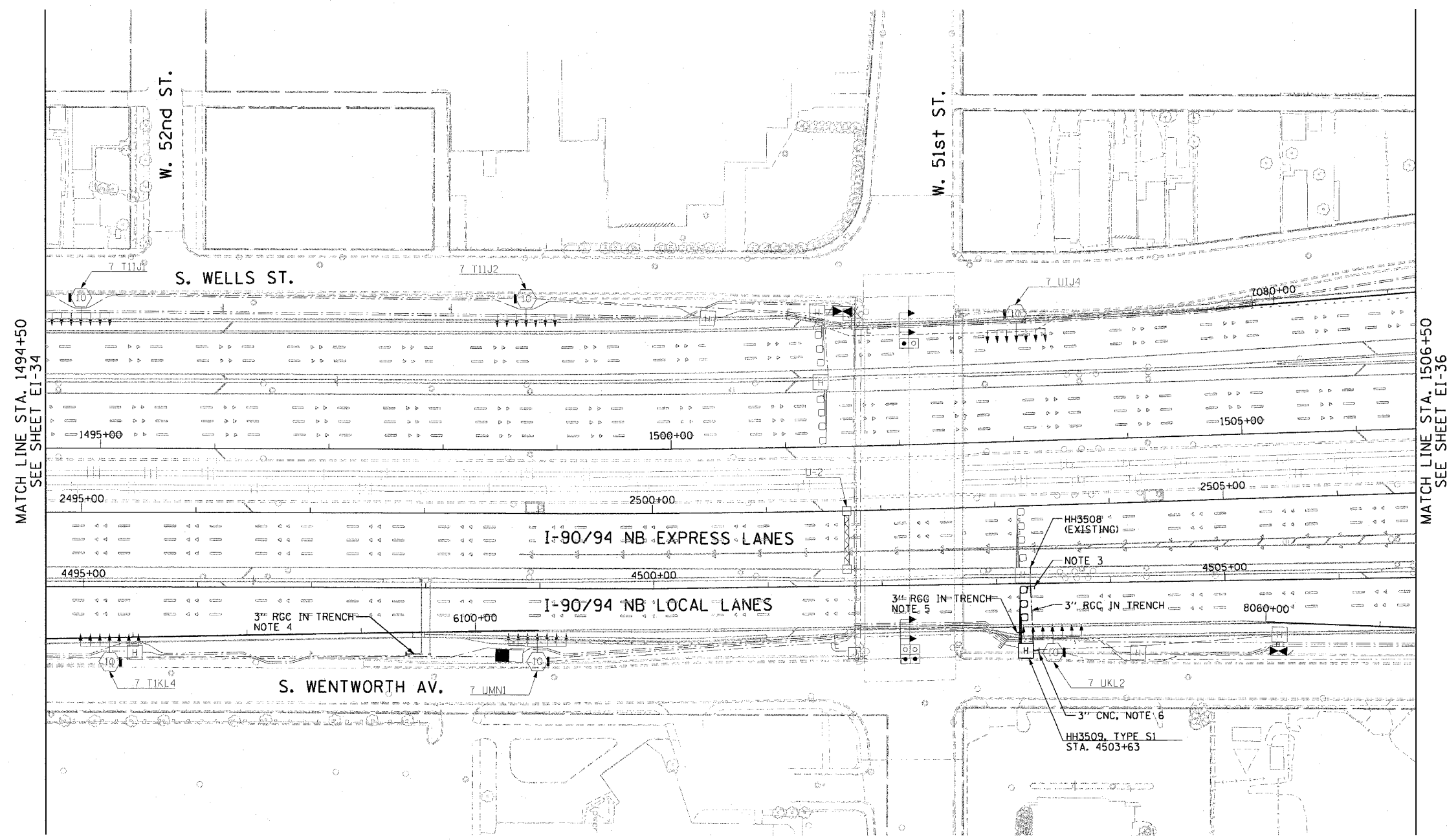

MATCH LINE STA. 1494+50
SEE SHEET EI-34

MATCH LINE STA. 1506+50
SEE SHEET EI-36

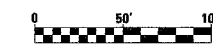

EI-35

CTE | AECOM

REVISIONS	
NAME	DATE

ILLINOIS DEPARTMENT OF TRANSPORTATION
 F.A.I. 90/94 (DAN RYAN EXPRESSWAY)
 GARFIELD BLVD TO 31ST STREET (NB LOCAL LANES)
 ELECTRICAL INFRASTRUCTURE PLAN

SCALE: 1"=50'
 DATE: June 9, 2006

DRAWN BY: HAR
 CHECKED BY: JPC

06/07/2006 10:50:50 AM

F.A.I. RTE.	SECTION	COUNTY	TOTAL SHEETS	SHEET NO.
90/94		COOK	565	299
STA. 1506+50.00 TO STA. 1518+00.00				
FED. ROAD DIST. NO. 1		ILLINOIS	FED. AID PROJECT	
62301		2021-922 PT2 ETC 2324.6-1P) R-10		

NOTES:

- SEE DRAWINGS EI-100 AND EI-101 FOR ELECTRICAL SYMBOLS AND ABBREVIATIONS.
- SEE DRAWINGS EI-102, EI-103, AND EI-104 FOR TYPICAL HANDHOLE INSTALLATION DETAILS.
- THE CONTRACTOR SHALL LOCATE THE EXISTING CONDUIT STUB-OUT INSTALLED IN IDOT CONTRACT NO. 62300 AND CONNECT THE PROPOSED CONDUIT.
- CONDUIT STUB-OUT SHALL EXTEND 2' BEYOND THE PAVED AREA AND BE CAPPED FOR FUTURE USE.
- EXTEND CONDUIT STUB-OUT 2' BEYOND THE SIGN STRUCTURE FOUNDATION. CAP FOR FUTURE USE.
- UNLESS NOTED OTHERWISE, ALL ITEMS AND WORK SHOWN IN HEAVY LINE WEIGHT ON THIS DRAWING ARE PROPOSED NEW ITEMS AND WORK.

p:\40468\elec\18-cntrs 18 & 19\contract 18\18V180362a.dwg

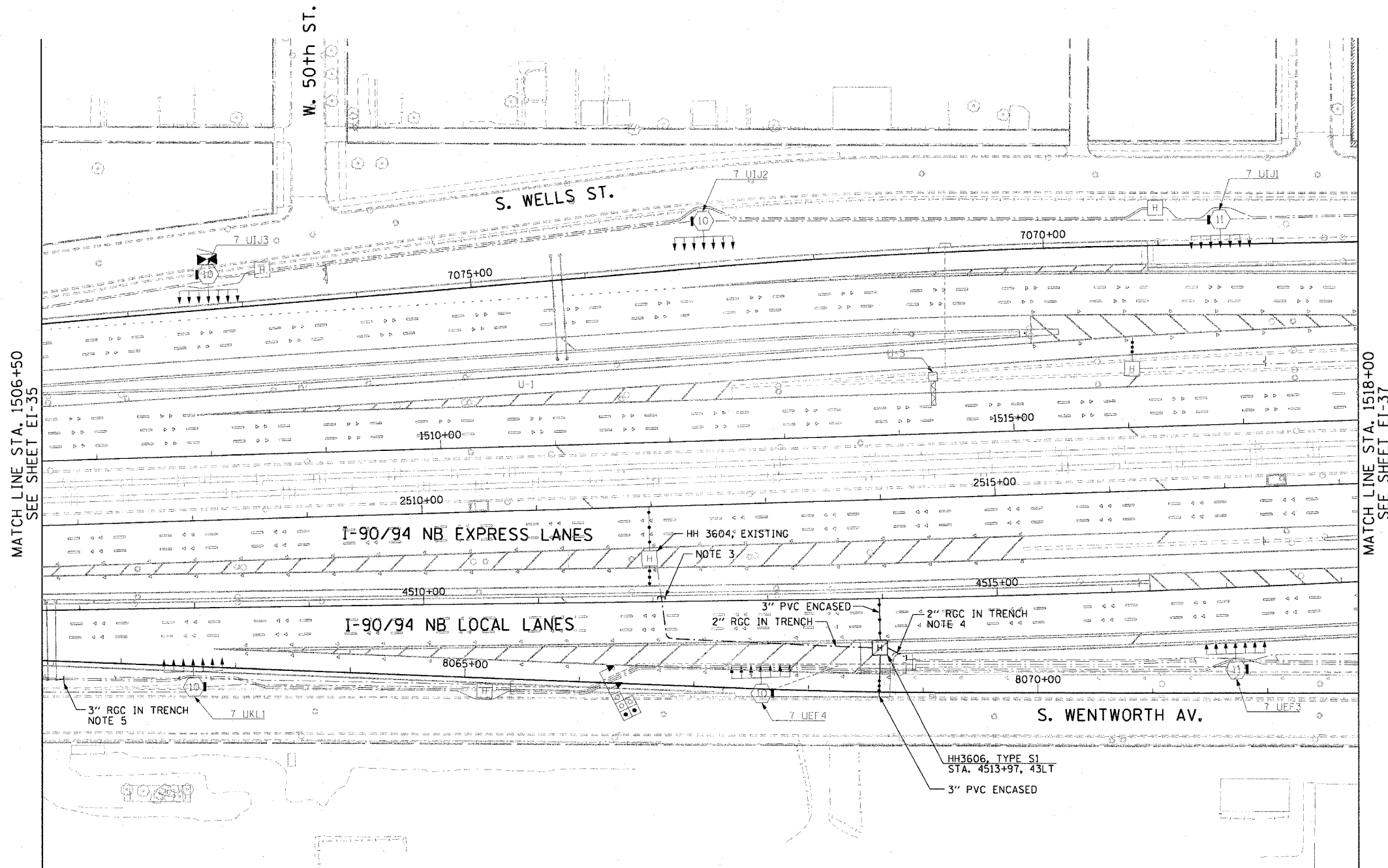
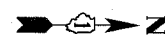

MATCH LINE STA. 1506+50
SEE SHEET EI-35

MATCH LINE STA. 1518+00
SEE SHEET EI-37

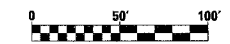

EI-36

REVISIONS	
NAME	DATE

ILLINOIS DEPARTMENT OF TRANSPORTATION
F.A.I. 90/94 (DAN RYAN EXPRESSWAY)
GARFIELD BLVD TO 31ST STREET (NB LOCAL LANES)

ELECTRICAL INFRASTRUCTURE PLAN

SCALE: 1"=50'
DATE: June 9, 2006
DRAWN BY: HAR
CHECKED BY: JPC

CTE | AECOM

06/07/2006 10:50:51 AM

F.A.I. RTE.	SECTION	COUNTY	TOTAL SHEETS	SHEET NO.
90/94		COOK	565	300
STA. 1518+00.00 TO STA. 1529+50.00				
FED. ROAD DIST. NO. 1		ILLINOIS	FED. AID PROJECT	
62301		(2021-922 PT2 ETC 2324.6-1P) R-10		

NOTES:

- SEE DRAWINGS EI-100 AND EI-101 FOR ELECTRICAL SYMBOLS AND ABBREVIATIONS.
- SEE DRAWING EI-106 FOR ELECTRIC DUCTBANK DETAILS.
- UNLESS NOTED OTHERWISE, ALL ITEMS AND WORK SHOWN IN HEAVY LINE WEIGHT ON THIS DRAWING ARE PROPOSED NEW ITEMS AND WORK.
- SEE DRAWING EI-107 FOR TYPICAL INSTALLATION DETAILS OF DUCTBANK AT AN EXISTING BRIDGE ABUTMENT. DUCTBANK SHALL BE TERMINATED AT THE STATIONS AND OFFSETS SHOWN APPROXIMATELY 30" BELOW FINISHED GRADE.
- EXTEND CONDUIT STUB-OUT 2' BEYOND THE SIGN STRUCTURE FOUNDATION. CAP FOR FUTURE USE.

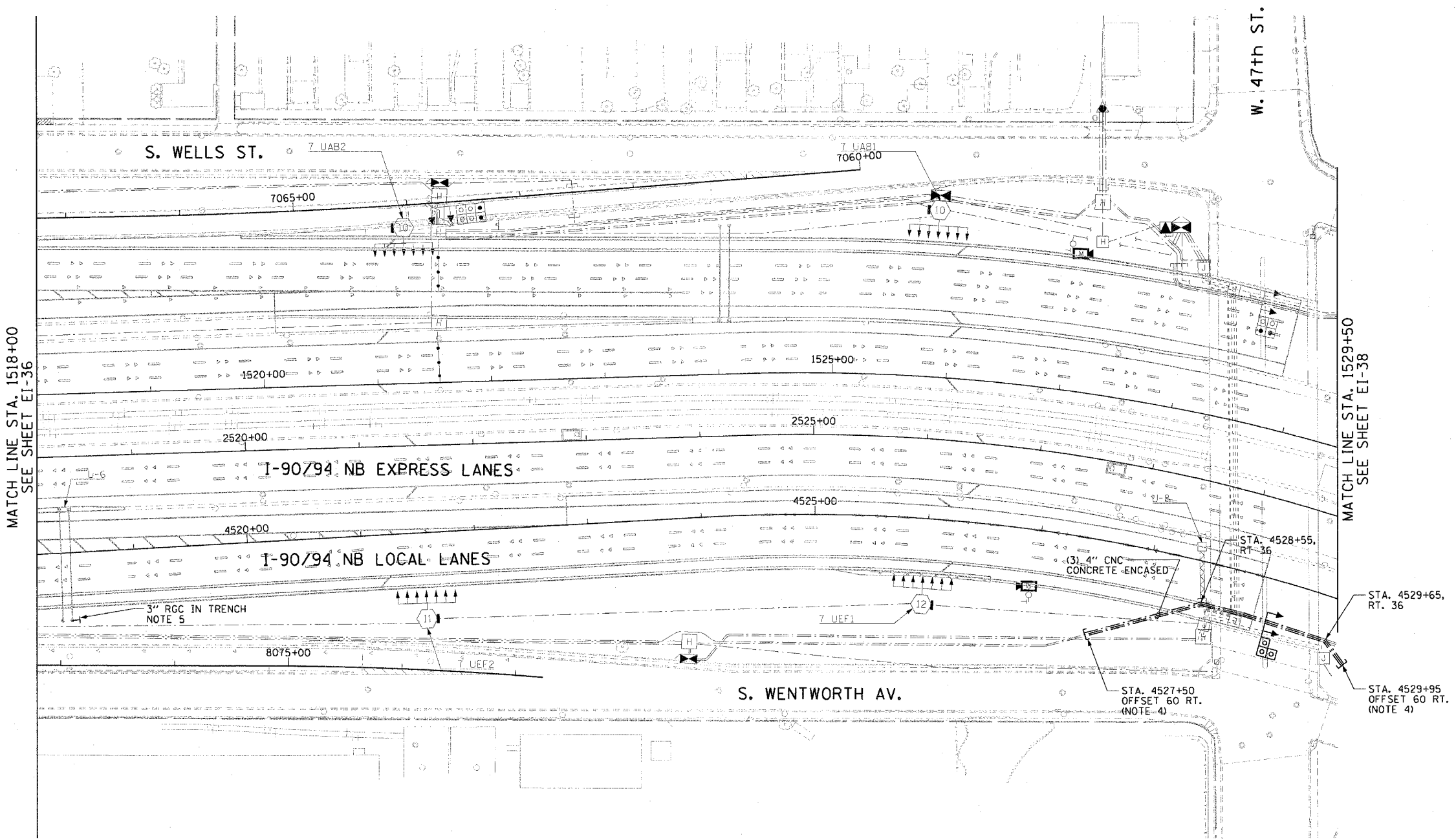

MATCH LINE STA. 1518+00
SEE SHEET EI-36

MATCH LINE STA. 1529+50
SEE SHEET EI-38

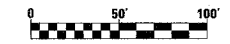

EI-37

REVISIONS	
NAME	DATE

ILLINOIS DEPARTMENT OF TRANSPORTATION
F.A.I. 90/94 (DAN RYAN EXPRESSWAY)
GARFIELD BLVD TO 31ST STREET (NB LOCAL LANES)

ELECTRICAL INFRASTRUCTURE PLAN

SCALE: 1"=50'
DATE: June 9, 2006
DRAWN BY: HAR
CHECKED BY: JPC

CTE | AECOM

06/07/2006 12:27:40 PM