

FINAL SURVEY BY DATE
 SURVEYED BY
 PLOTTED BY
 NOTE BOOK NO.
 DATE
 AREAS CHECKED

ORIGINAL SURVEY BY DATE
 SURVEYED BY
 PLOTTED BY
 NOTE BOOK NO.
 DATE
 AREAS CHECKED

F.A.I. RTE. 94/90	SECTION 0	COUNTY COOK	TOTAL SHEETS 565	SHEET NO. 501
FED. ROAD DIST. NO. 1 62301		ILLINOIS FED. AID PROJECT 12021-922 PT2, ETC. 2324.6-IPR-10		

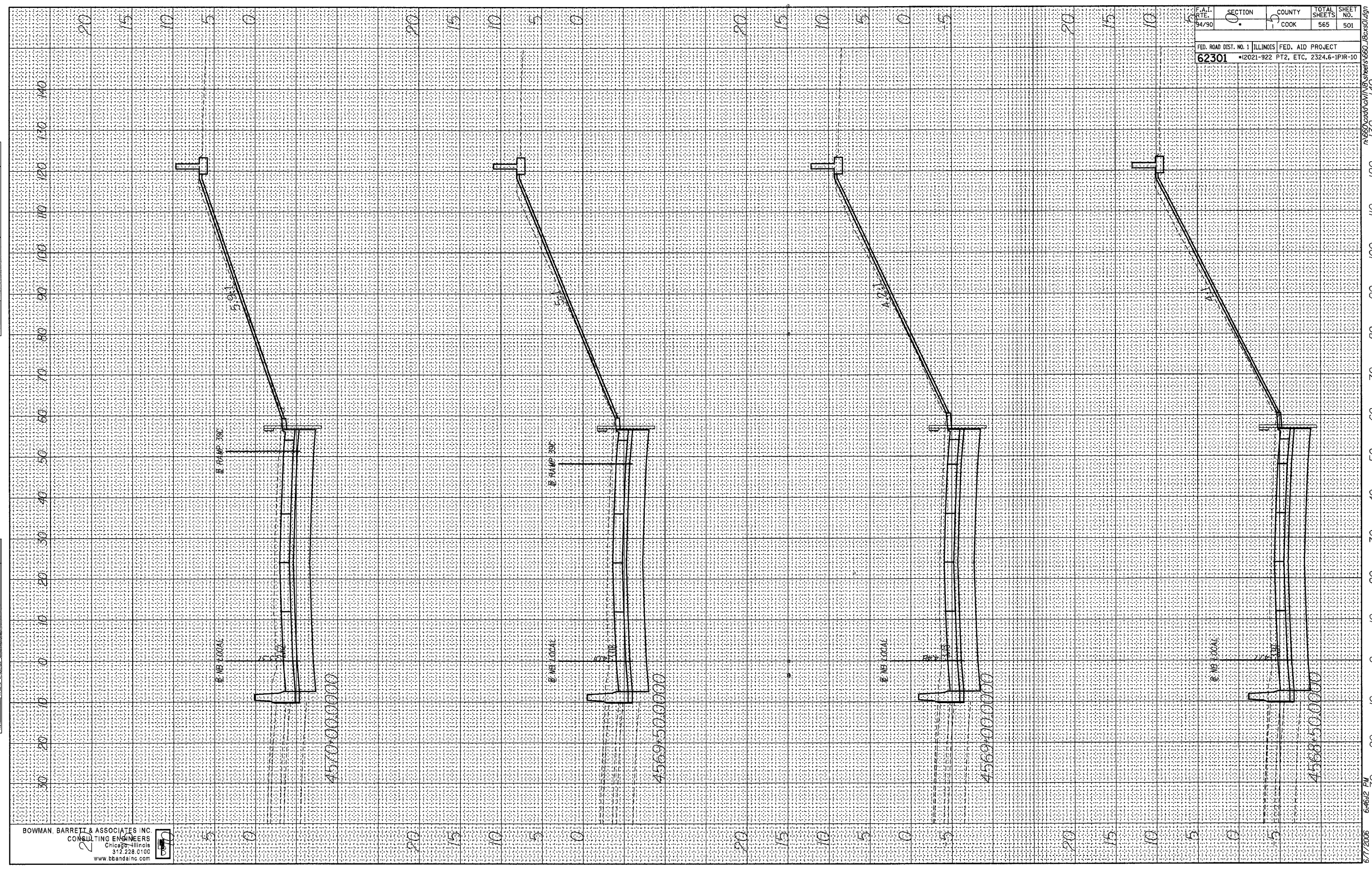

BOWMAN, BARRETT & ASSOCIATES INC.
 CONSULTING ENGINEERS
 Chicago, Illinois
 312.228.0100
 www.bbainc.com



6/7/2006 6:46:12 PM

FINAL SURVEY PLOTTED AREAS CHECKED

DATE _____ BY _____

NO. _____

ORIGINAL SURVEY PLOTTED AREAS CHECKED

DATE _____ BY _____

NO. _____

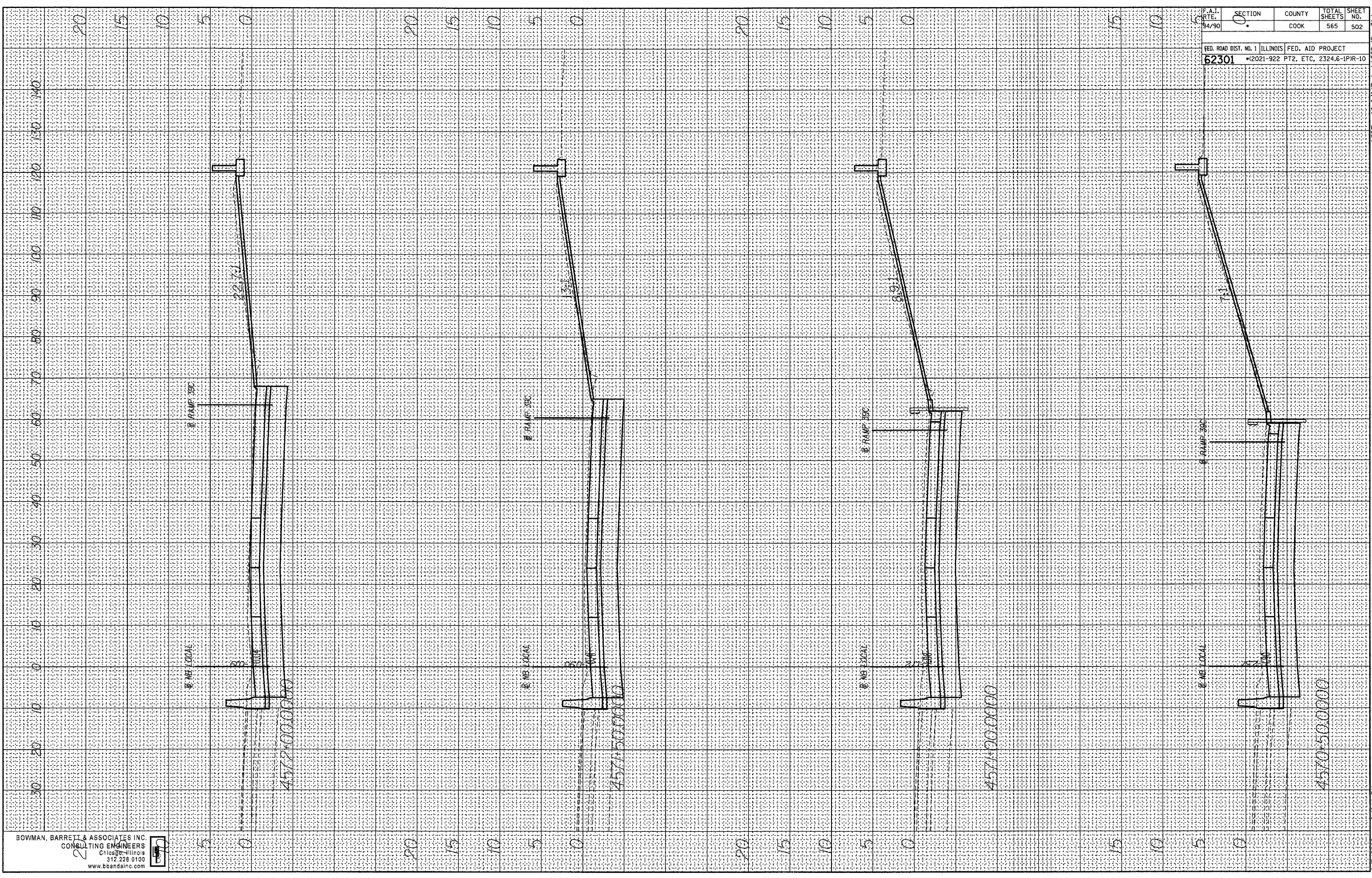

BOWMAN, BARRETT & ASSOCIATES INC.
CONSULTING ENGINEERS
Chicago, Illinois
312.228.0100
www.bbainc.com

F.A.I. RTE. 94/90	SECTION 0	COUNTY COOK	TOTAL SHEETS 565	SHEET NO. 502
FED. ROAD DIST. NO. 1 ILLINOIS FED. AID PROJECT				
62301 •(2021-922 PT2, ETC, 2324.6-1PR-10				

6/7/2006 6:46:14 PM

FINAL SURVEY
 NOTE BOOK
 NO. _____
 SURVEYED _____
 TEMPLATE _____
 AREA _____
 CHECKED _____
 BY _____
 DATE _____

ORIGINAL SURVEY
 NOTE BOOK
 NO. _____
 SURVEYED _____
 TEMPLATE _____
 AREA _____
 CHECKED _____
 BY _____
 DATE _____

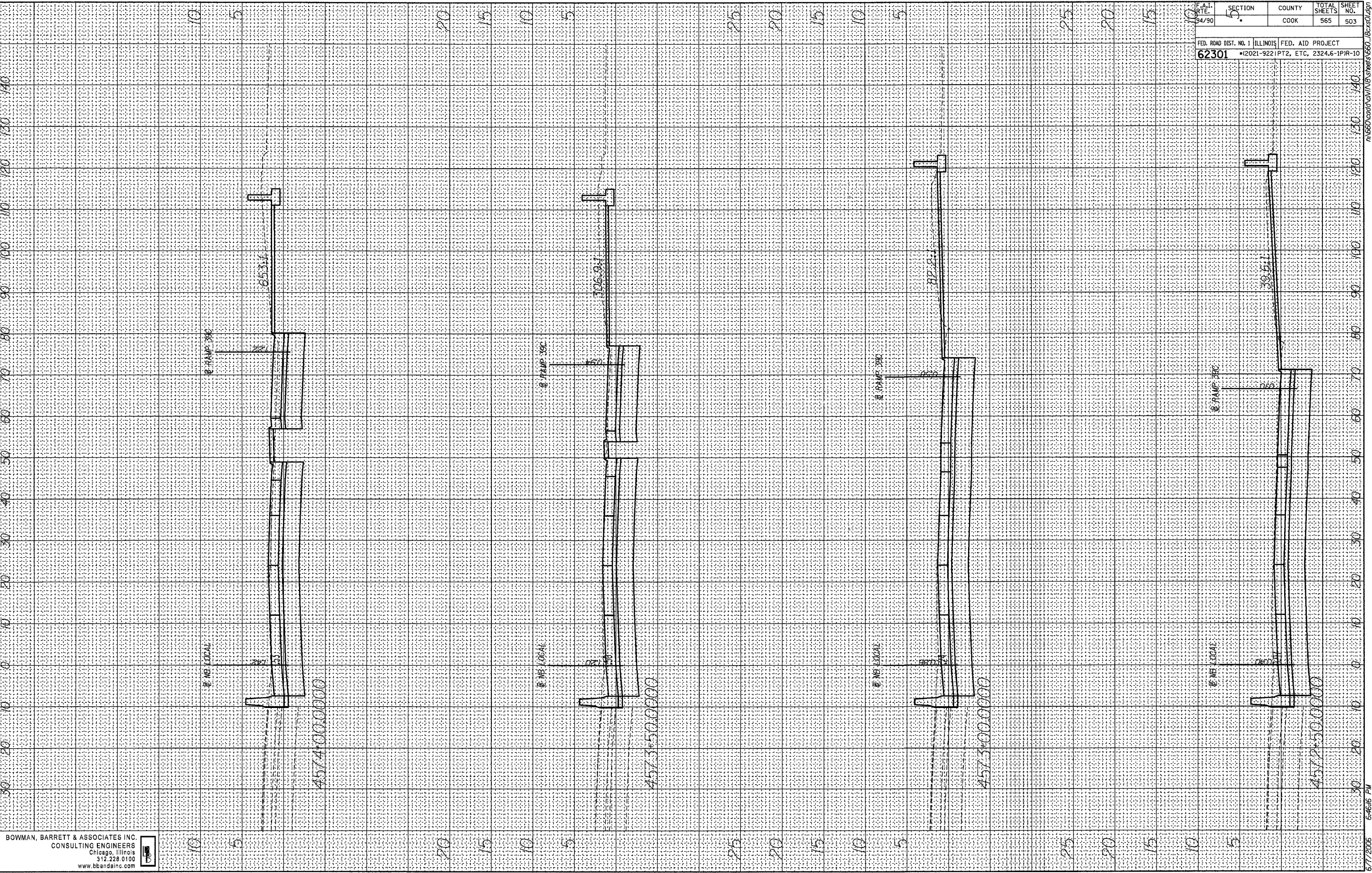

F.A.I. RTE. 94/90	SECTION 4	COUNTY COOK	TOTAL SHEETS 565	SHEET NO. 503
FED. ROAD DIST. NO. 1 ILLINOIS		FED. AID PROJECT		
62301		*2021-9221PT2, ETC, 2324.6-1PR-10		

BOWMAN, BARRETT & ASSOCIATES INC.
 CONSULTING ENGINEERS
 Chicago, Illinois
 312.228.0100
 www.bbainc.com



6/7/2006 6:46:16 PM

FINAL SURVEY BY DATE
 SURVEYED BY
 TEMPLATE
 NOTE BOOK NO.
 AREAS CHECKED

ORIGINAL SURVEY BY DATE
 SURVEYED BY
 TEMPLATE
 NOTE BOOK NO.
 AREAS CHECKED

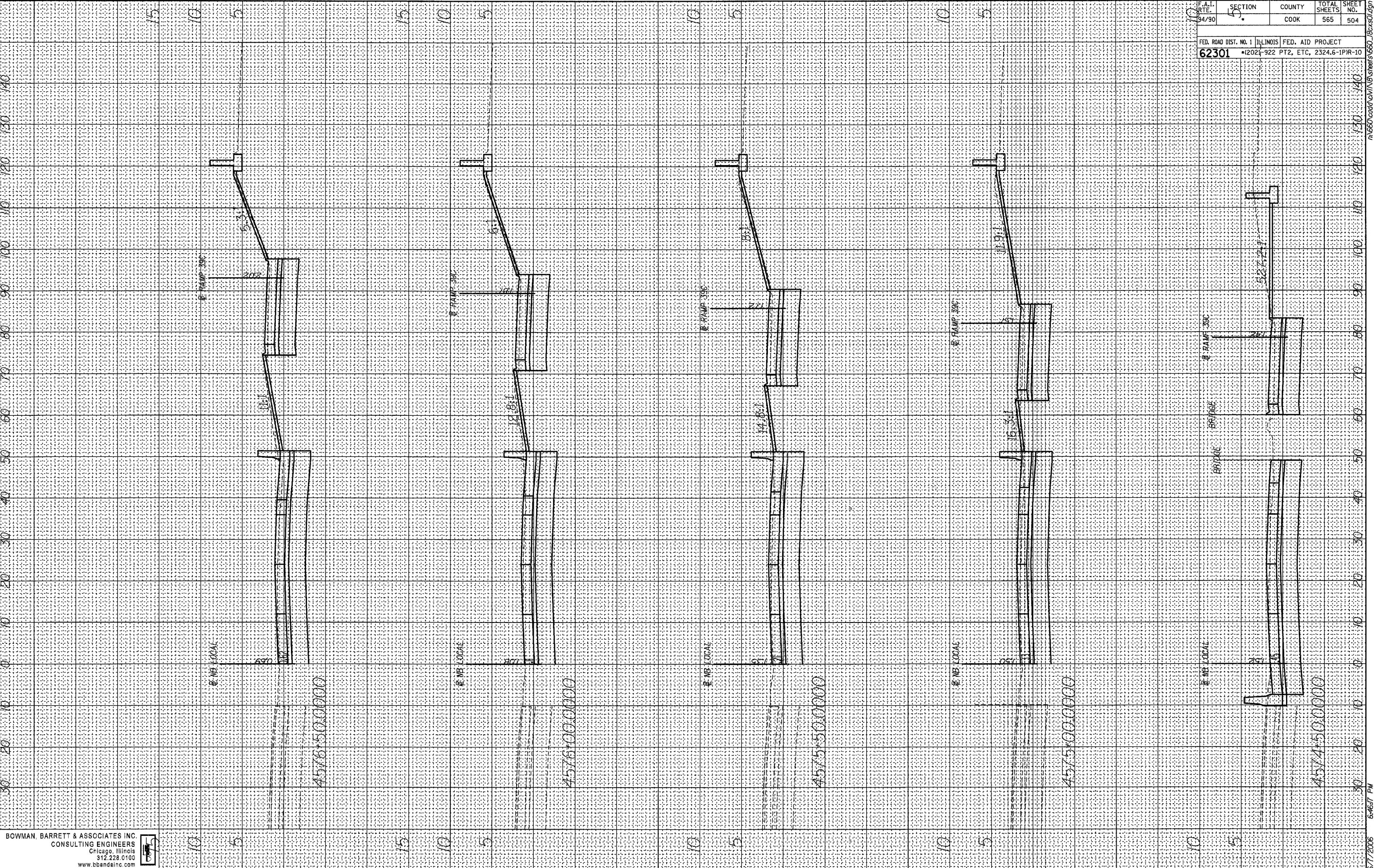

BOWMAN, BARRETT & ASSOCIATES INC.
 CONSULTING ENGINEERS
 Chicago, Illinois
 312.228.0100
 www.bbainc.com

F.A.I. RTE. 94/90	SECTION 4	COUNTY COOK	TOTAL SHEETS 565	SHEET NO. 504
FED. ROAD DIST. NO. 1		ILLINOIS		FED. AID PROJECT
62301		*2021-922 PT2, ETC, 2324.6-1PR-10		

ns660.cad/cad/176/sheets/660_16x80.dgn

6/7/2006 6:46:07 PM

FINAL SURVEY
 SURVEYED BY _____ DATE _____
 PLOTTED BY _____
 NOTE BOOK NO. _____
 AREAS CHECKED _____

ORIGINAL SURVEY
 SURVEYED BY _____ DATE _____
 PLOTTED BY _____
 NOTE BOOK NO. _____
 AREAS CHECKED _____

F.A.I. DIST. NO.	SECTION	COUNTY	TOTAL SHEETS	SHEET NO.
62301	4	COOK	565	505
FED. ROAD DIST. NO. 1 ILLINOIS FED. AID PROJECT				
#(2021-922 PT2, ETC, 2324.6-IPR-10				

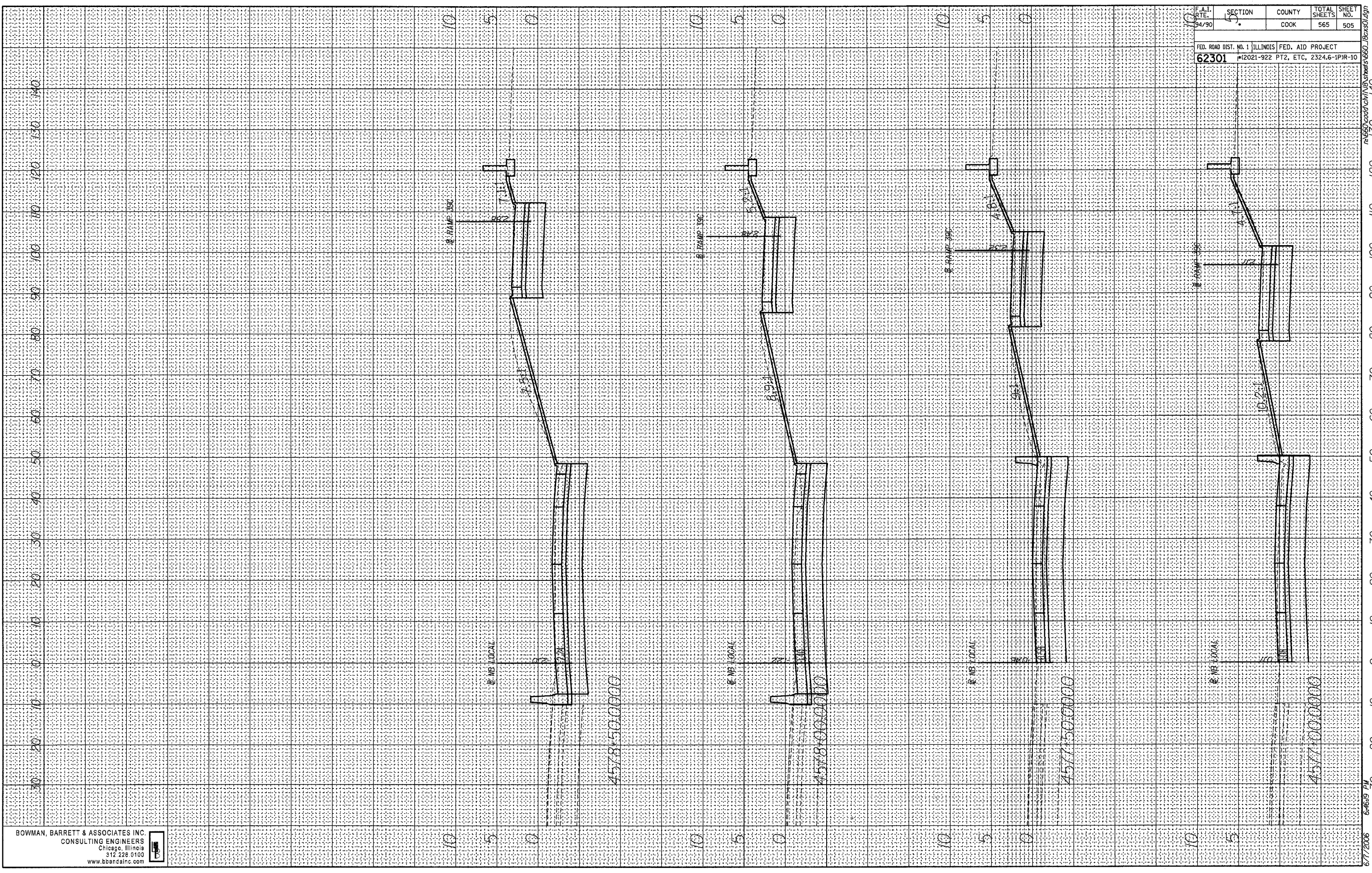

BOWMAN, BARRETT & ASSOCIATES INC.
 CONSULTING ENGINEERS
 Chicago, Illinois
 312 228 0100
 www.bbainc.com

6/7/2006 6:46:19 PM

ORIGINAL SURVEY
 SURVEYED _____ BY _____ DATE _____
 NOTE BOOK _____
 TEMPLATE _____
 AREAS _____
 AREAS CHECKED _____

FINAL SURVEY
 SURVEYED _____ BY _____ DATE _____
 NOTE BOOK _____
 TEMPLATE _____
 AREAS _____
 AREAS CHECKED _____

BOWMAN, BARRETT & ASSOCIATES INC.
 CONSULTING ENGINEERS
 Chicago, Illinois
 312.228.0100
 www.bbainc.com

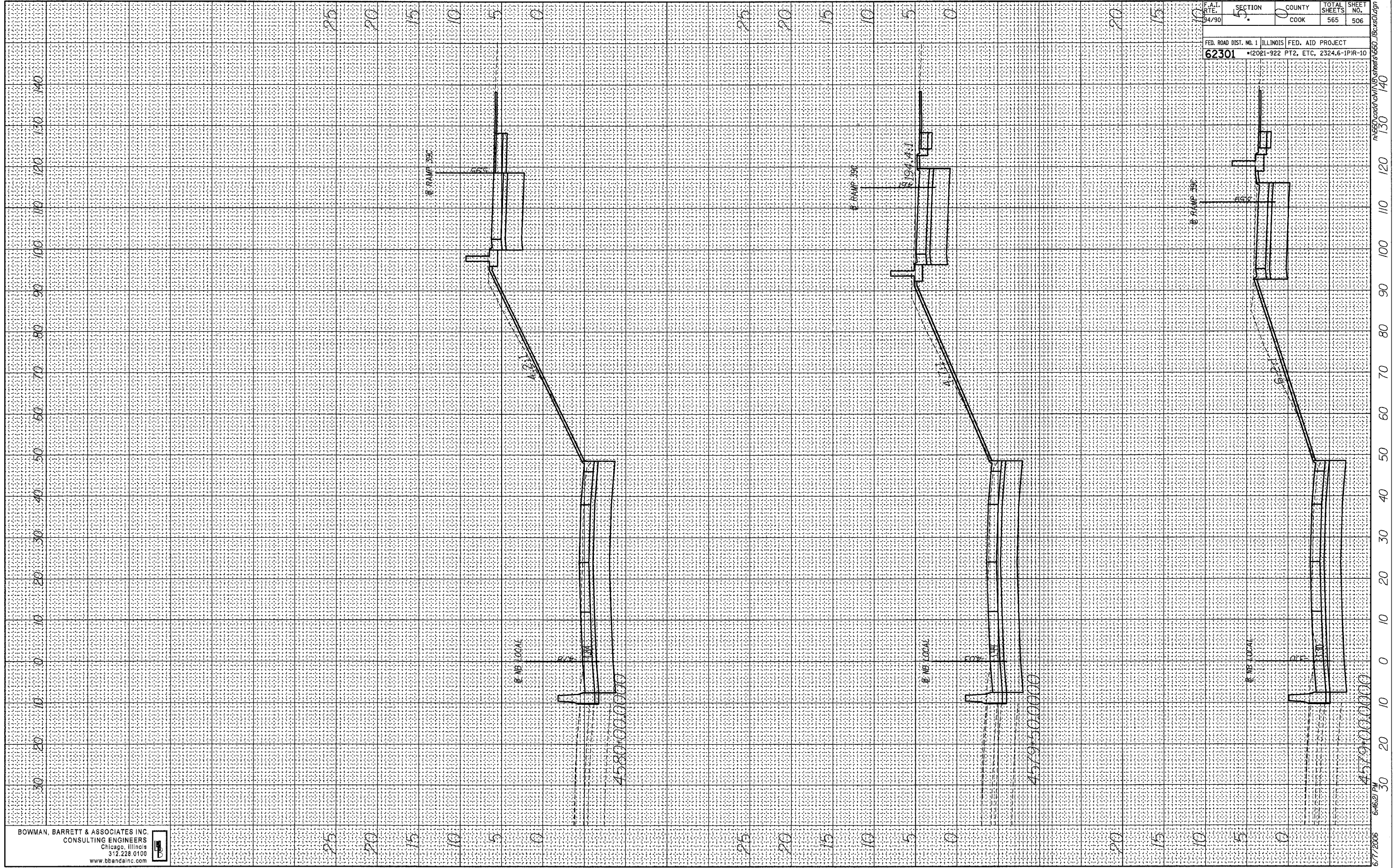

F.A.I. RTE.	SECTION	COUNTY	TOTAL SHEETS	SHEET NO.
94/90	5	COOK	565	506

FED. ROAD DIST. NO. 1 ILLINOIS FED. AID PROJECT
 62301 *12021-922 PT2, ETC, 2324.6-1PIR-10

6/7/2006 6:46:21 PM m:\660\road\dwg\116163\sheet506_1bxs01.dwg

SURVEYED _____ BY _____ DATE _____
 PLOTTED _____
 NOTE BOOK _____
 AREAS CHECKED _____
 NO. _____

ORIGINAL SURVEY _____ BY _____ DATE _____
 PLOTTED _____
 NOTE BOOK _____
 AREAS CHECKED _____
 NO. _____

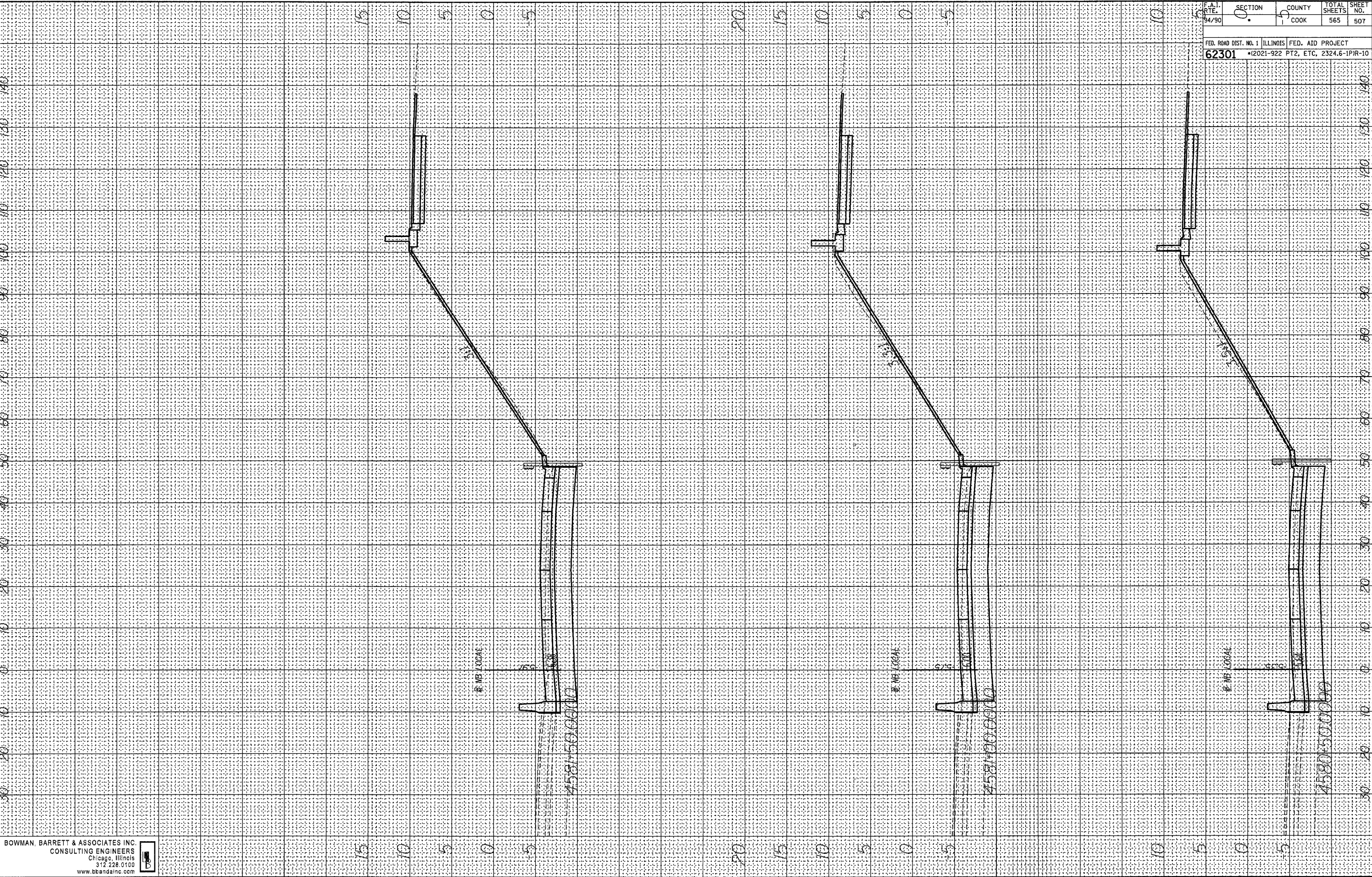

F.A.I. R.T.E. 94/90	SECTION *	COUNTY COOK	TOTAL SHEETS 565	SHEET NO. 507
FED. ROAD DIST. NO. 1 ILLINOIS FED. AID PROJECT 62301 •(2021-922 PT2, ETC, 2324.6-1PIR-10				

BOWMAN, BARRETT & ASSOCIATES INC.
 CONSULTING ENGINEERS
 Chicago, Illinois
 312.228.0100
 www.bbandainc.com



6/7/2006 6:46:23 PM T:\6600\road\ch\m\1\6\Sheets\660_1Bx60.dgn

FINAL SURVEY
 SURVEYED _____ BY _____ DATE _____
 NOTE BOOK _____
 TEMPLATE _____
 AREAS CHECKED _____

ORIGINAL SURVEY
 SURVEYED _____ BY _____ DATE _____
 NOTE BOOK _____
 TEMPLATE _____
 AREAS CHECKED _____

F.A.I. RTE. 94/90	SECTION *	COUNTY COOK	TOTAL SHEETS 565	SHEET NO. 508
FED. ROAD DIST. NO. 1 ILLINOIS		FED. AID PROJECT		
62301		*2021-922 PT2, ETC, 2324.6-1PR-10		

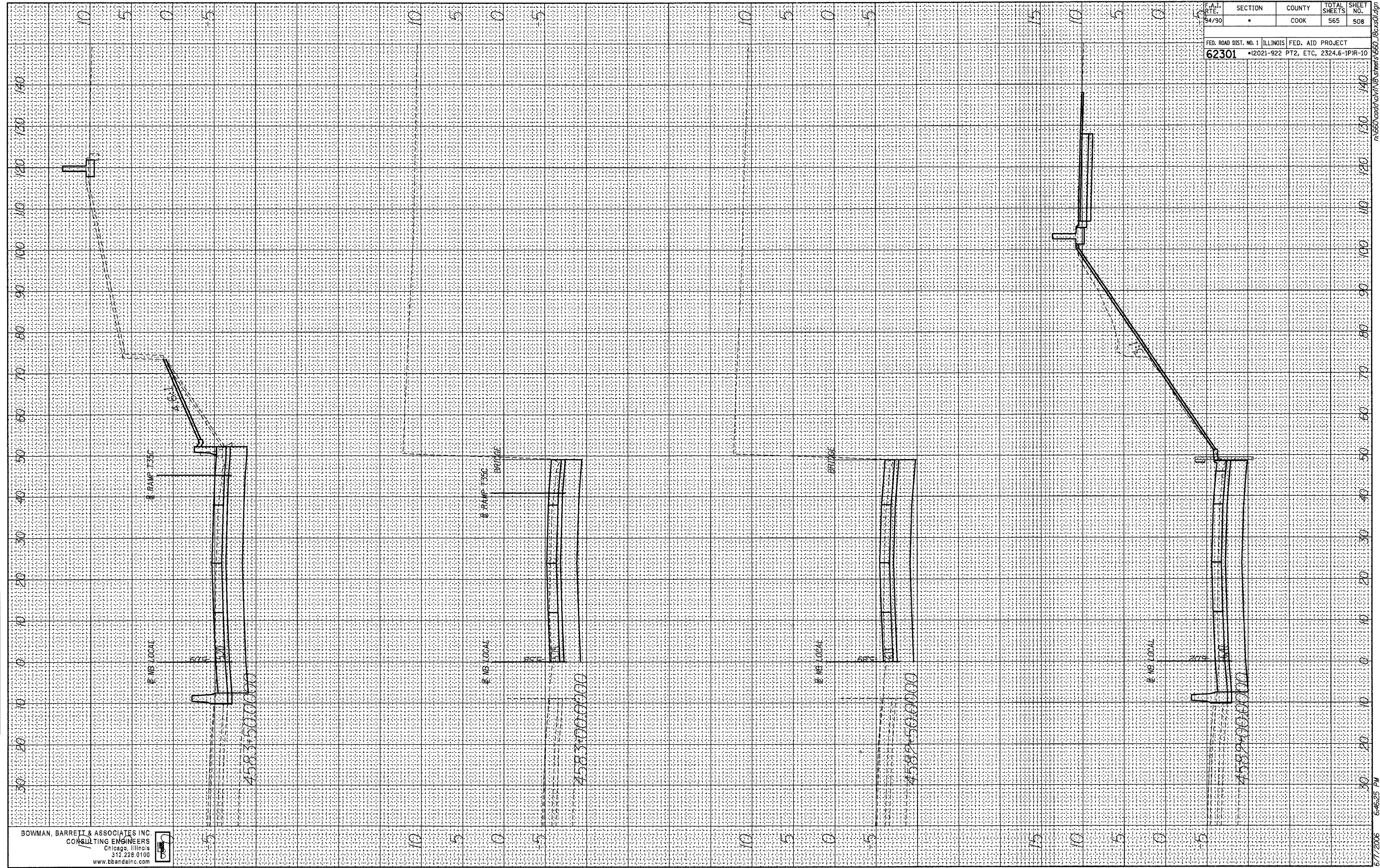

BOWMAN, BARRETT & ASSOCIATES INC
 CONSULTING ENGINEERS
 Chicago, Illinois
 312.228.0100
 www.bbainc.com



6/7/2006 6:46:25 PM

FINAL SURVEY BY DATE
 SURVEYED BY
 PLOTTED BY
 NOTE BOOK NO.
 AREAS CHECKED

ORIGINAL SURVEY BY DATE
 SURVEYED BY
 PLOTTED BY
 NOTE BOOK NO.
 AREAS CHECKED

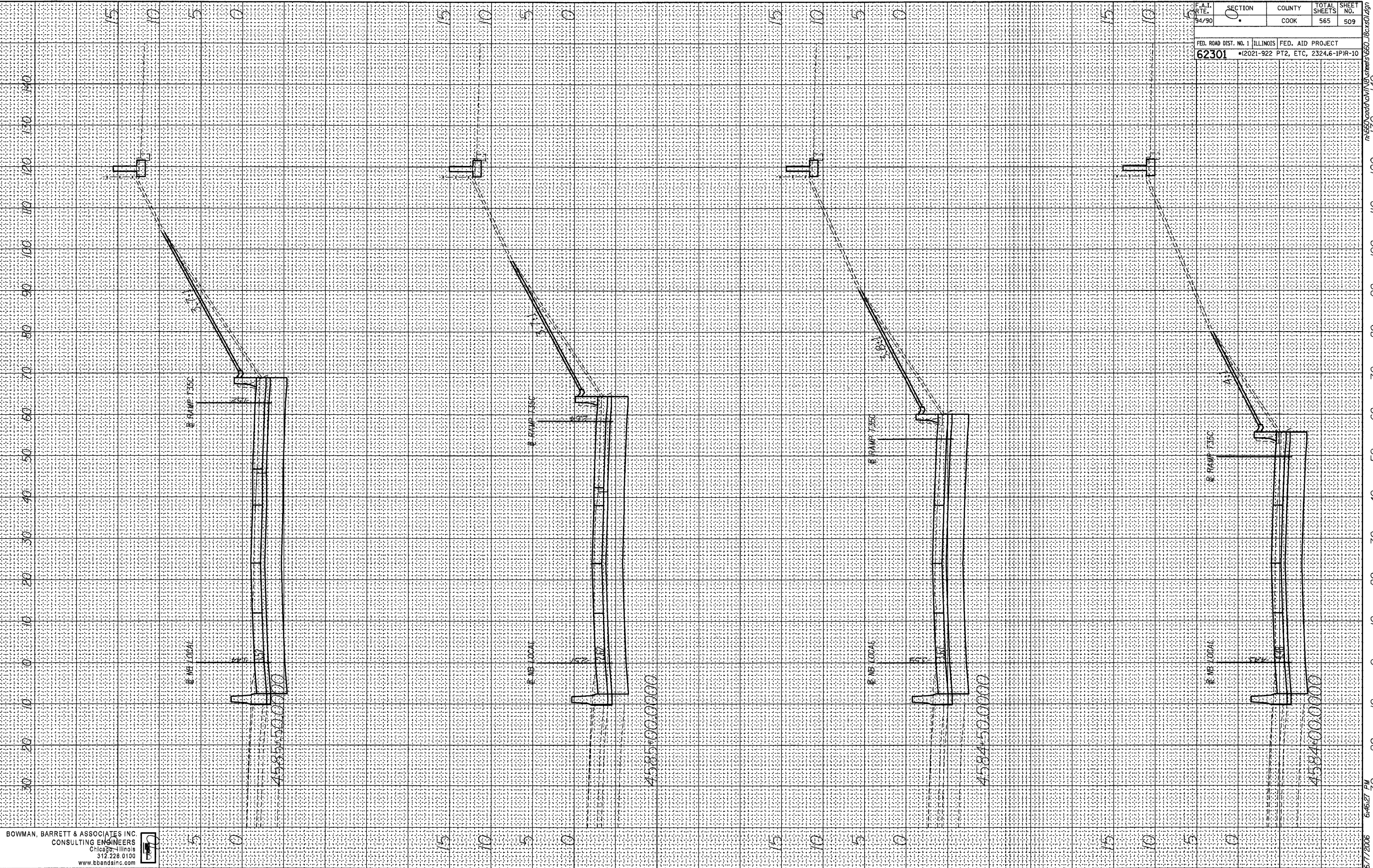

F.A.I. RTE. 94/90	SECTION 0	COUNTY COOK	TOTAL SHEETS 565	SHEET NO. 509
FED. ROAD DIST. NO. 1 ILLINOIS FED. AID PROJECT				
62301 •(2021-922 PT2, ETC, 2324.6-IPR-10				

BOWMAN, BARRETT & ASSOCIATES INC.
 CONSULTING ENGINEERS
 Chicago, Illinois
 312.228.0100
 www.bbainc.com



6/7/2006 6:46:27 PM

FINAL SURVEY
 SURVEYED BY
 NOTE BOOK NO.
 TEMPLATE AREAS CHECKED
 DATE

ORIGINAL SURVEY
 SURVEYED BY
 NOTE BOOK NO.
 TEMPLATE AREAS CHECKED
 DATE

F.A.I. RTE. 94/90	SECTION 0	COUNTY COOK	TOTAL SHEETS 565	SHEET NO. 510
FED. ROAD DIST. NO. 1 ILLINOIS		FED. AID PROJECT		
62301		*12021-922 PT2, ETC, 2324.6-1PR-10		

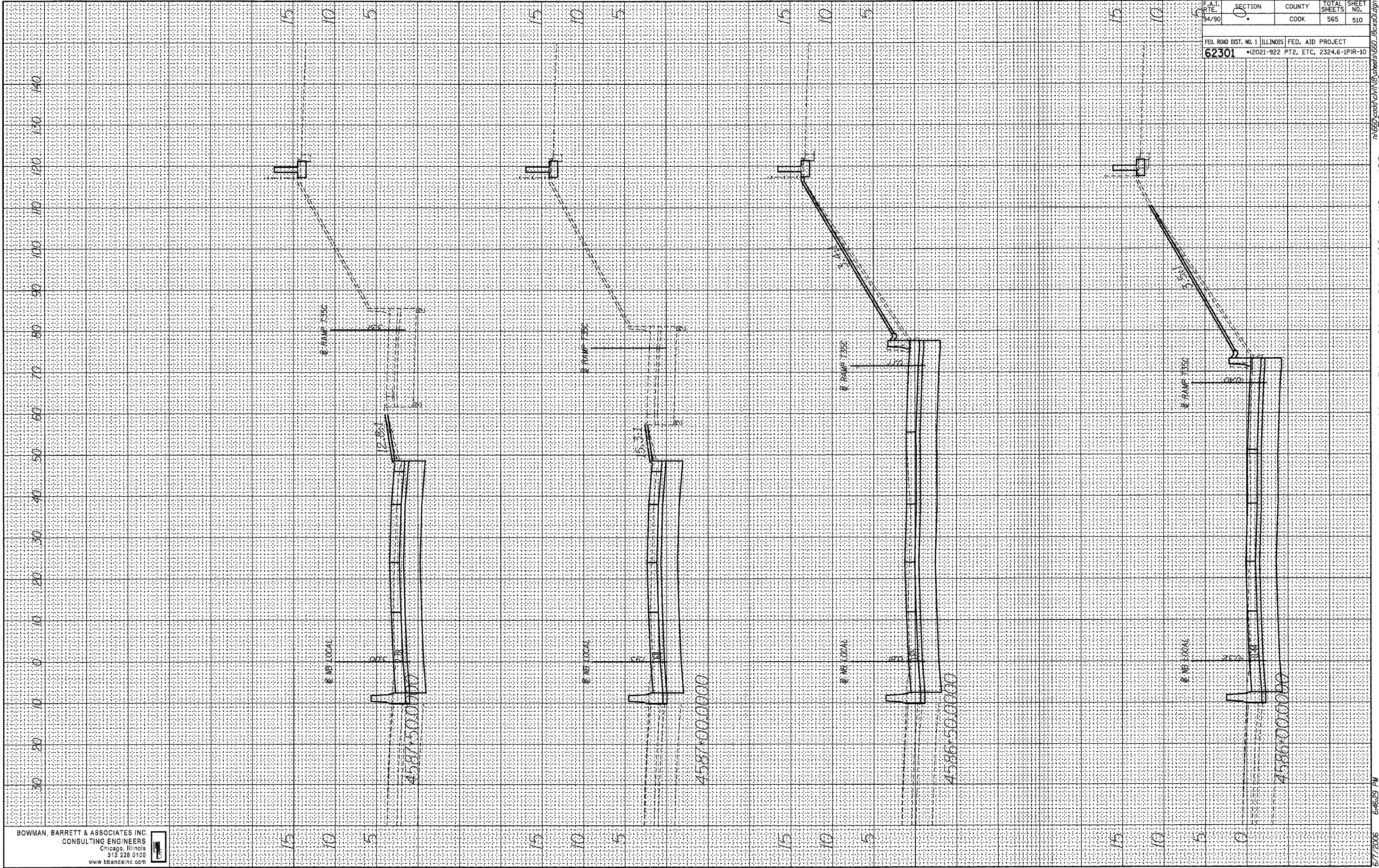

BOWMAN, BARRETT & ASSOCIATES INC.
 CONSULTING ENGINEERS
 Chicago, Illinois
 312.228.0100
 www.bbainc.com

6/7/2006 6:46:29 PM
 n:\660\road\cal\116\Sheet510.dwg

FINAL SURVEY BY DATE
 SURVEYED BY
 PLOTTED BY
 NOTE BOOK NO.
 DATE
 AREAS CHECKED

ORIGINAL SURVEY BY DATE
 SURVEYED BY
 PLOTTED BY
 NOTE BOOK NO.
 DATE
 AREAS CHECKED

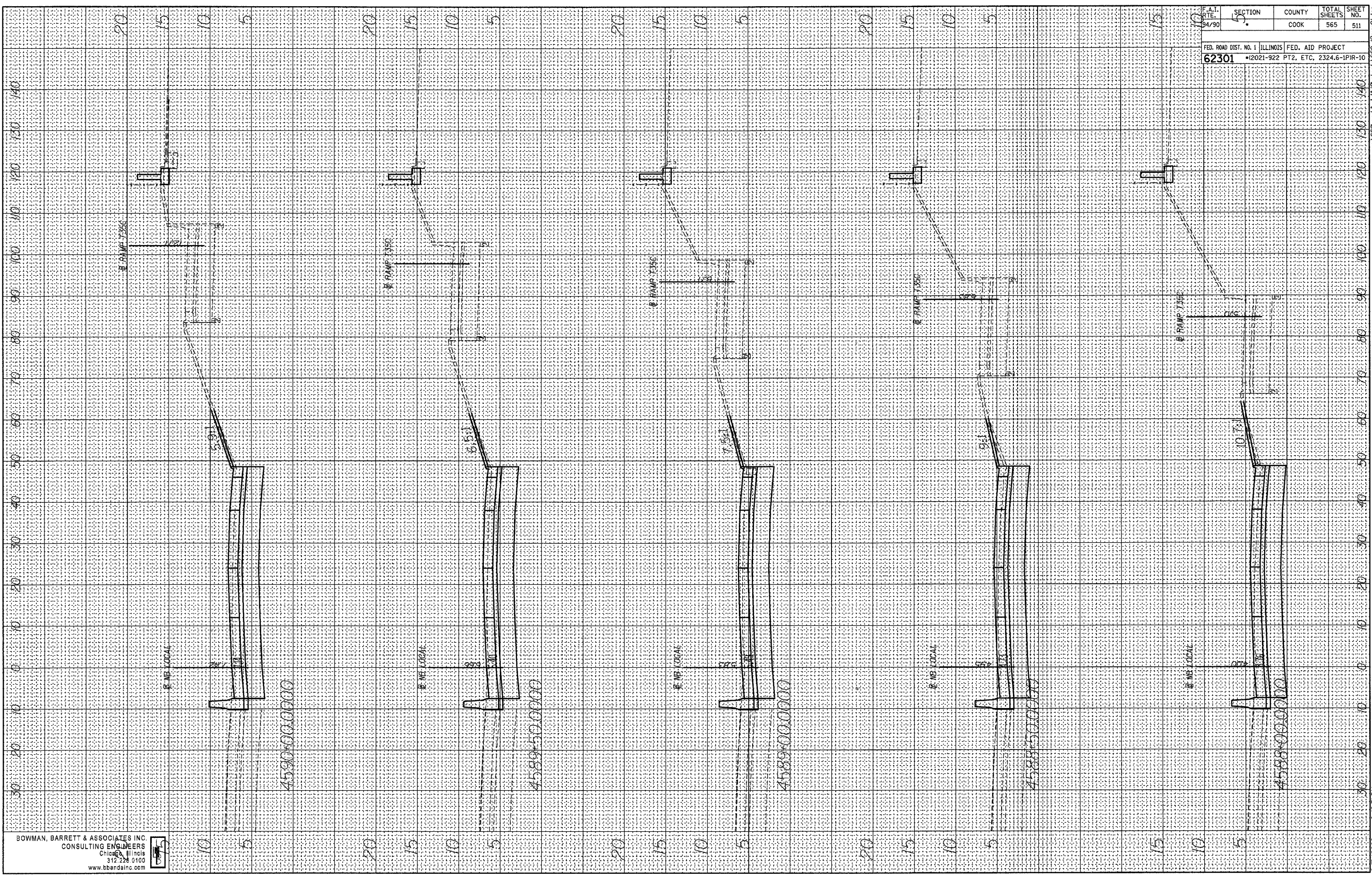

BOWMAN, BARRETT & ASSOCIATES INC.
 CONSULTING ENGINEERS
 Chicago, Illinois
 312.228.0100
 www.bbainc.com

F.A.I. RT. 94/90	SECTION 5	COUNTY COOK	TOTAL SHEETS 565	SHEET NO. 511
FED. ROAD DIST. NO. 1 ILLINOIS FED. AID PROJECT				
62301 (2021-922 PT2, ETC. 2324.6-IPR-10				

6/7/2006 6:46:31 PM

FINAL SURVEY BY DATE
 SURVEYED BY
 TEMPLATE NO.
 NOTE BOOK NO.
 AREAS CHECKED

ORIGINAL SURVEY BY DATE
 SURVEYED BY
 TEMPLATE NO.
 NOTE BOOK NO.
 AREAS CHECKED

F.A.I. RTE. 94/90	SECTION 5	COUNTY COOK	TOTAL SHEETS 565	SHEET NO. 512
FED. ROAD DIST. NO. 1		ILLINOIS	FED. AID PROJECT	
62301		*2021-922 PT2, ETC, 2324.6-1P1R-10		

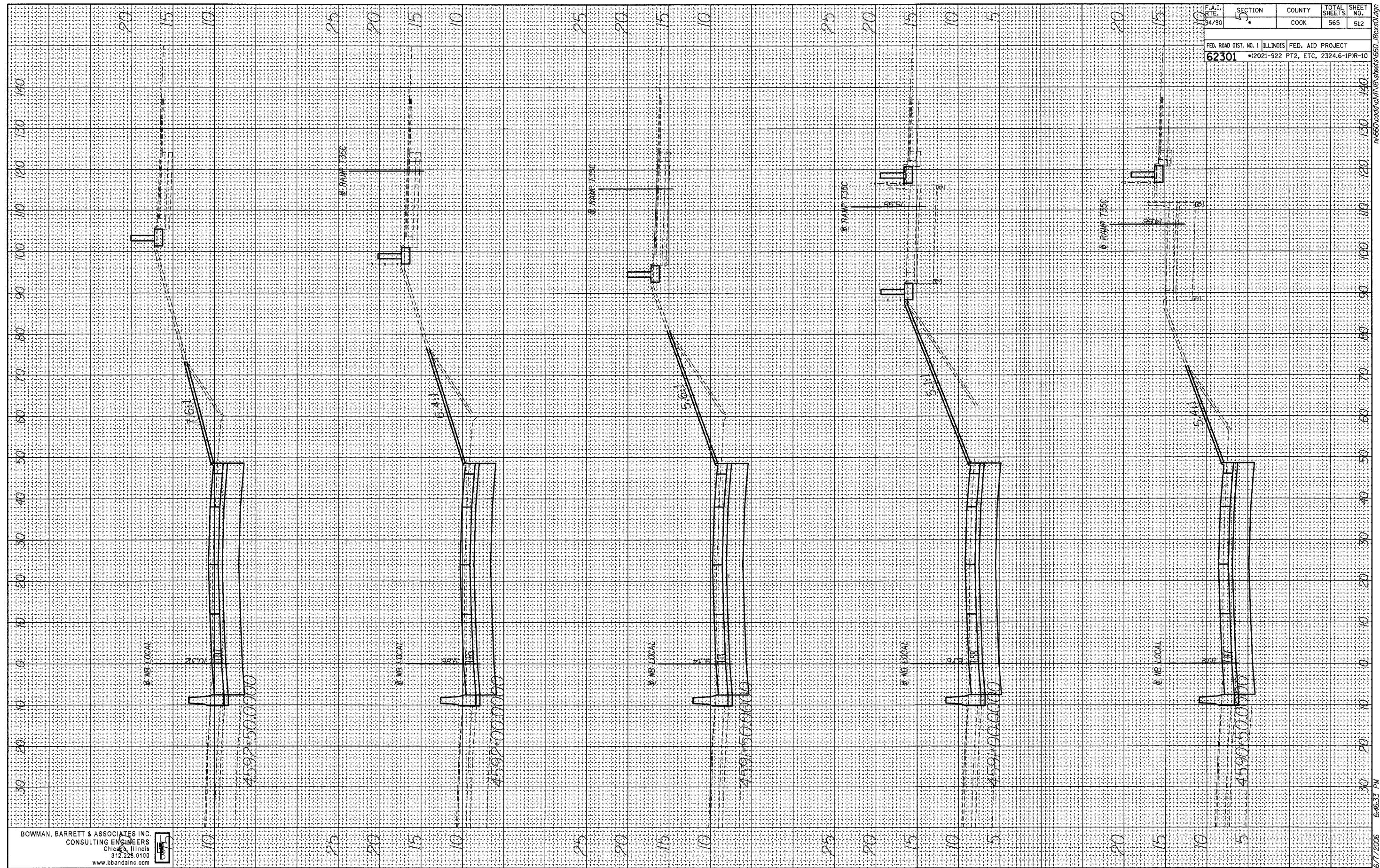

BOWMAN, BARRETT & ASSOCIATES INC.
 CONSULTING ENGINEERS
 Chicago, Illinois
 312.228.0100
 www.bbainc.com

6/7/2006 6:46:33 PM

FINAL SURVEY BY DATE
 SURVEYED PLOTTED
 NOTE BOOK PLATE
 NO. AREAS CHECKED

ORIGINAL SURVEY BY DATE
 SURVEYED PLOTTED
 NOTE BOOK PLATE
 NO. AREAS CHECKED

F.A.I. RTE. 94/90	SECTION 15	COUNTY COOK	TOTAL SHEETS 565	SHEET NO. 513
FED. ROAD DIST. NO. 1 ILLINOIS FED. AID PROJECT 62301 •(2021-922 PT2, ETC, 2324.6-1P)R-10				

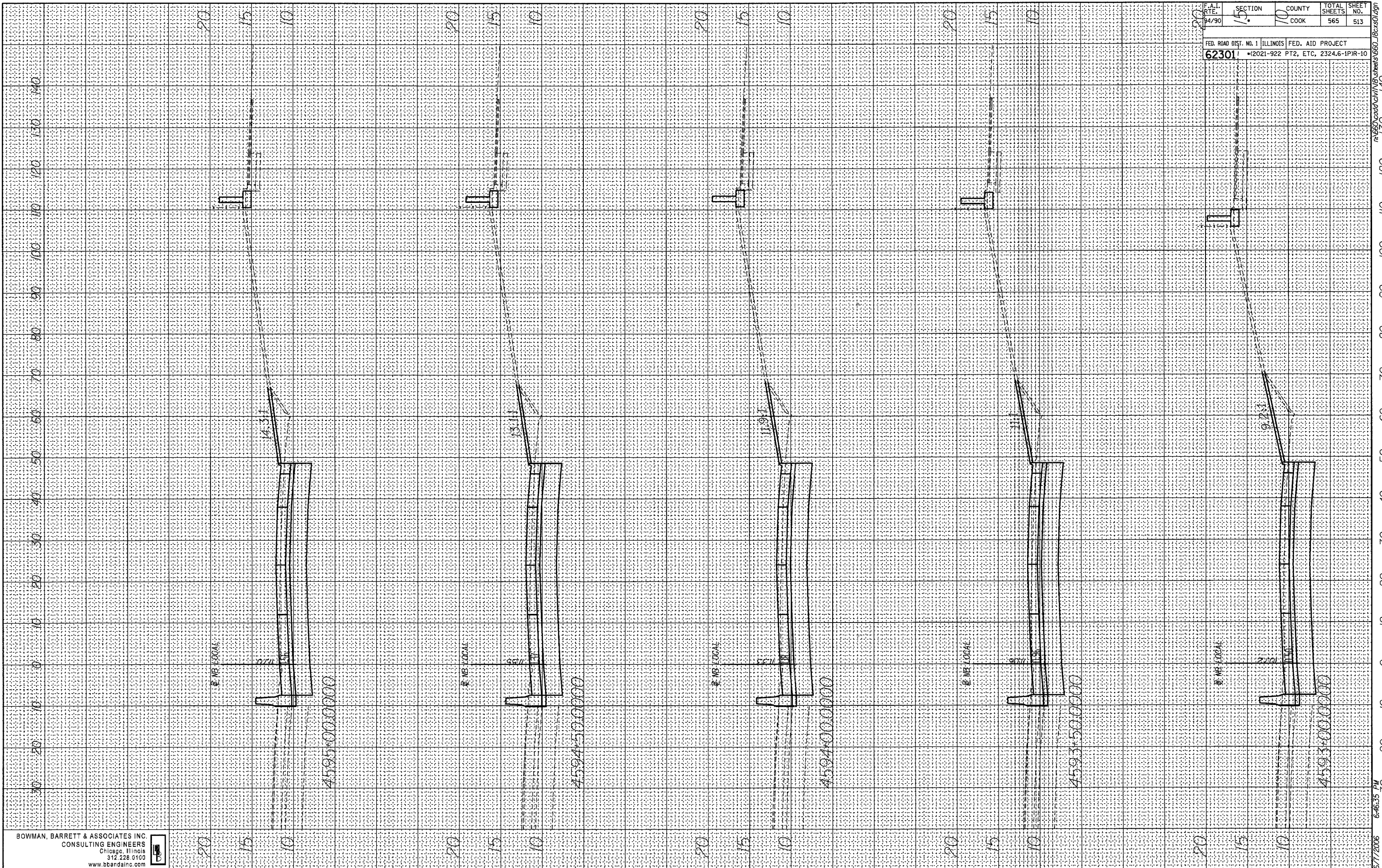

BOWMAN, BARRETT & ASSOCIATES INC.
 CONSULTING ENGINEERS
 Chicago, Illinois
 312.228.0100
 www.bbainc.com



6/7/2006 6:46:35 PM

FINAL SURVEY BY DATE
 SURVEYED BY
 PLOTTED BY
 NOTE BOOK NO.
 AREAS CHECKED

ORIGINAL SURVEY BY DATE
 SURVEYED BY
 PLOTTED BY
 NOTE BOOK NO.
 AREAS CHECKED

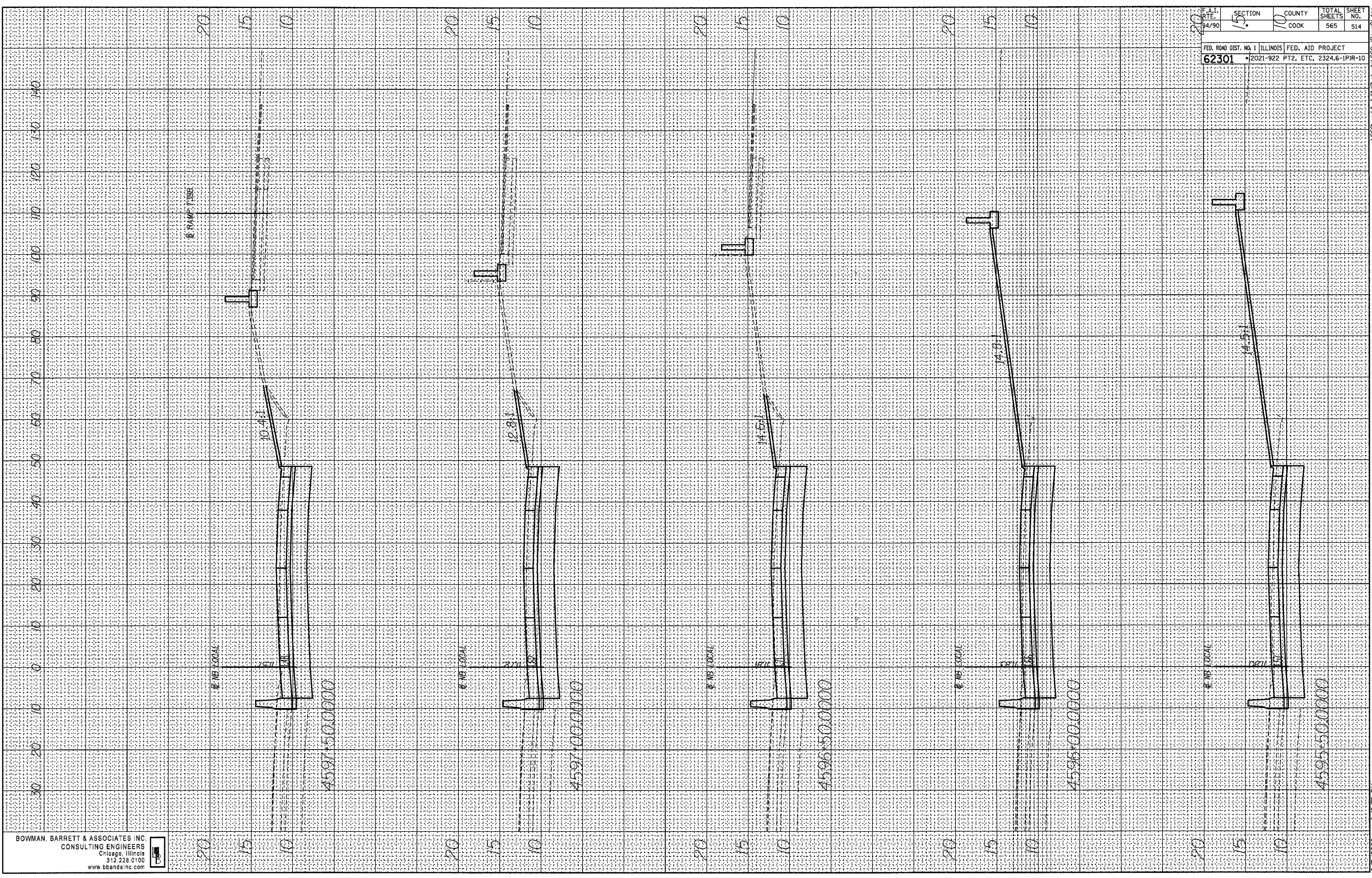

BOWMAN, BARRETT & ASSOCIATES INC.
 CONSULTING ENGINEERS
 Chicago, Illinois
 312.228.0100
 www.bbainc.com



F.A.I. DATE	SECTION	COUNTY	TOTAL SHEETS	SHEET NO.
04/90	15	COOK	565	514
FED. ROAD DIST. NO. 1 ILLINOIS FED. AID PROJECT				
62301 2021-922 PT2, ETC. 2324.6-IP1R-10				

6/7/2006 6:46:37 PM

FINAL SURVEY DATE
 SURVEYED BY
 NOTE BOOK NO.
 TEMPLATE AREAS CHECKED

ORIGINAL SURVEY DATE
 SURVEYED BY
 NOTE BOOK NO.
 TEMPLATE AREAS CHECKED

F.A.I. RTE. 94/90	SECTION 10	COUNTY COOK	TOTAL SHEETS 565	SHEET NO. 515
FED. ROAD DIST. NO. 1 ILLINOIS FED. AID PROJECT				
62301 *2021-922 PT2, ETC, 2324.6-1PR-10				

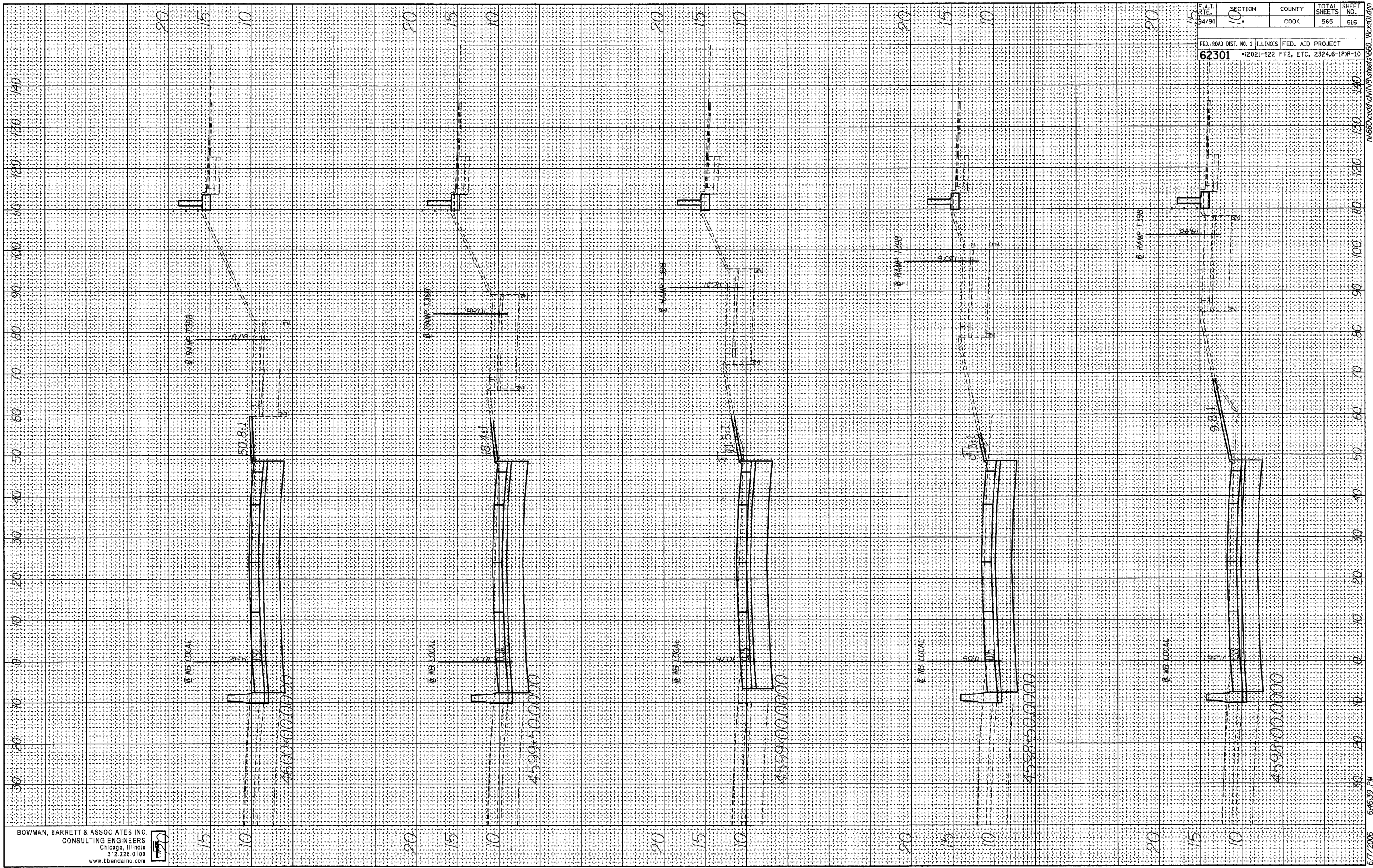

BOWMAN, BARRETT & ASSOCIATES INC
 CONSULTING ENGINEERS
 Chicago, Illinois
 312.228.0100
 www.bbainc.com

6/7/2006 6:46:39 PM

FINAL SURVEY
 SURVEYED BY _____ DATE _____
 NOTE BOOK _____
 TEMPLATE _____
 AREA'S _____
 AREAS DELETED _____

ORIGINAL SURVEY
 SURVEYED BY _____ DATE _____
 NOTE BOOK _____
 TEMPLATE _____
 AREA'S _____
 AREAS DELETED _____

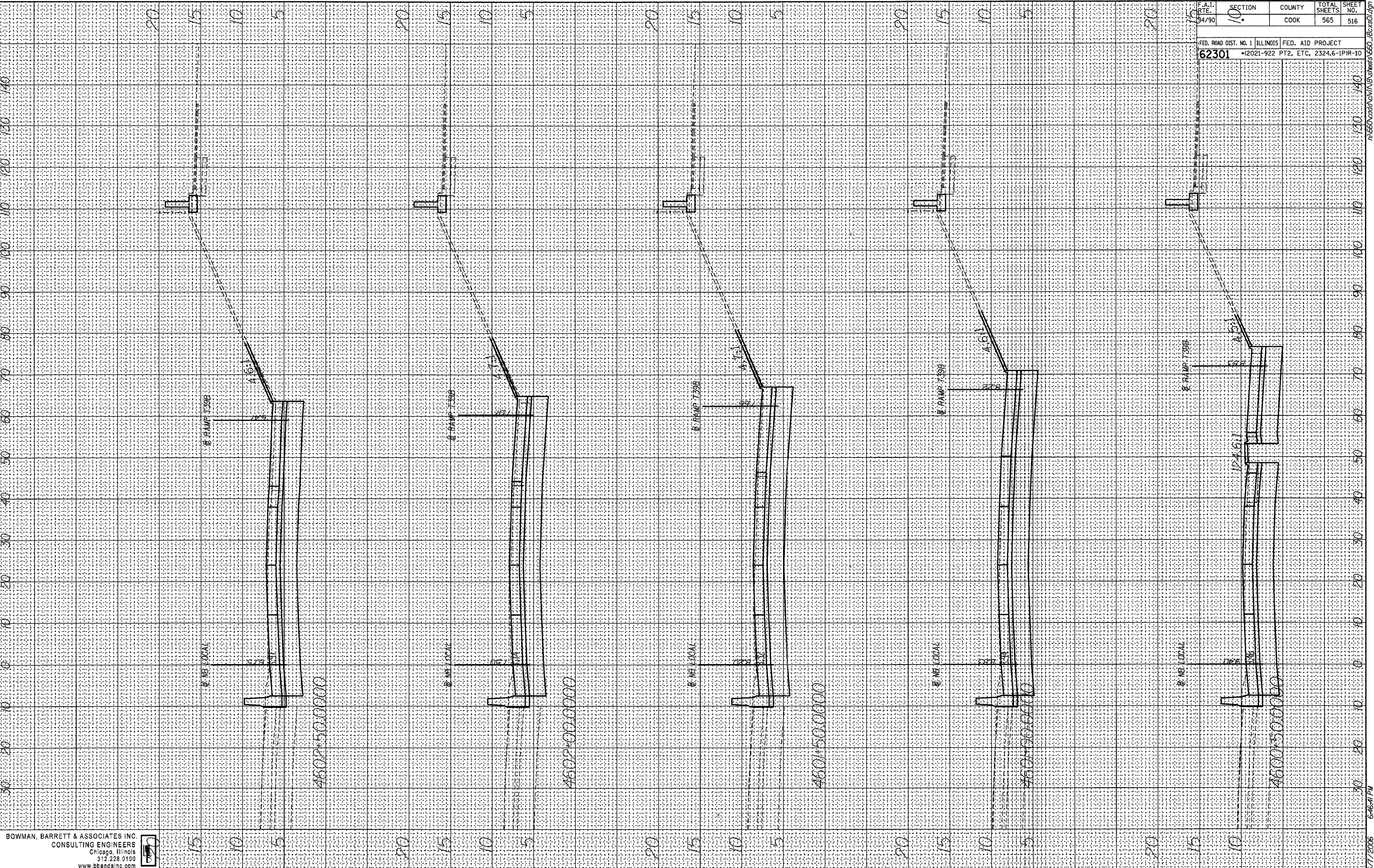

BOWMAN, BARRETT & ASSOCIATES INC.
 CONSULTING ENGINEERS
 Chicago, Illinois
 312.228.0100
 www.bbainc.com

F.A.T. RTE. 94/90	SECTION 10	COUNTY COOK	TOTAL SHEETS 565	SHEET NO. 516
FED. ROAD DIST. NO. 1 ILLINOIS FED. AID PROJECT				
62301 •(2021-922 PT2, ETC, 2324.6-1PIR-10				

5/7/2006 6:46:41 PM

FINAL SURVEY
 SURVEYED BY
 NOTE BOOK NO.
 TEMPLATE AREAS CHECKED
 DATE

ORIGINAL SURVEY
 SURVEYED BY
 NOTE BOOK NO.
 TEMPLATE AREAS CHECKED
 DATE

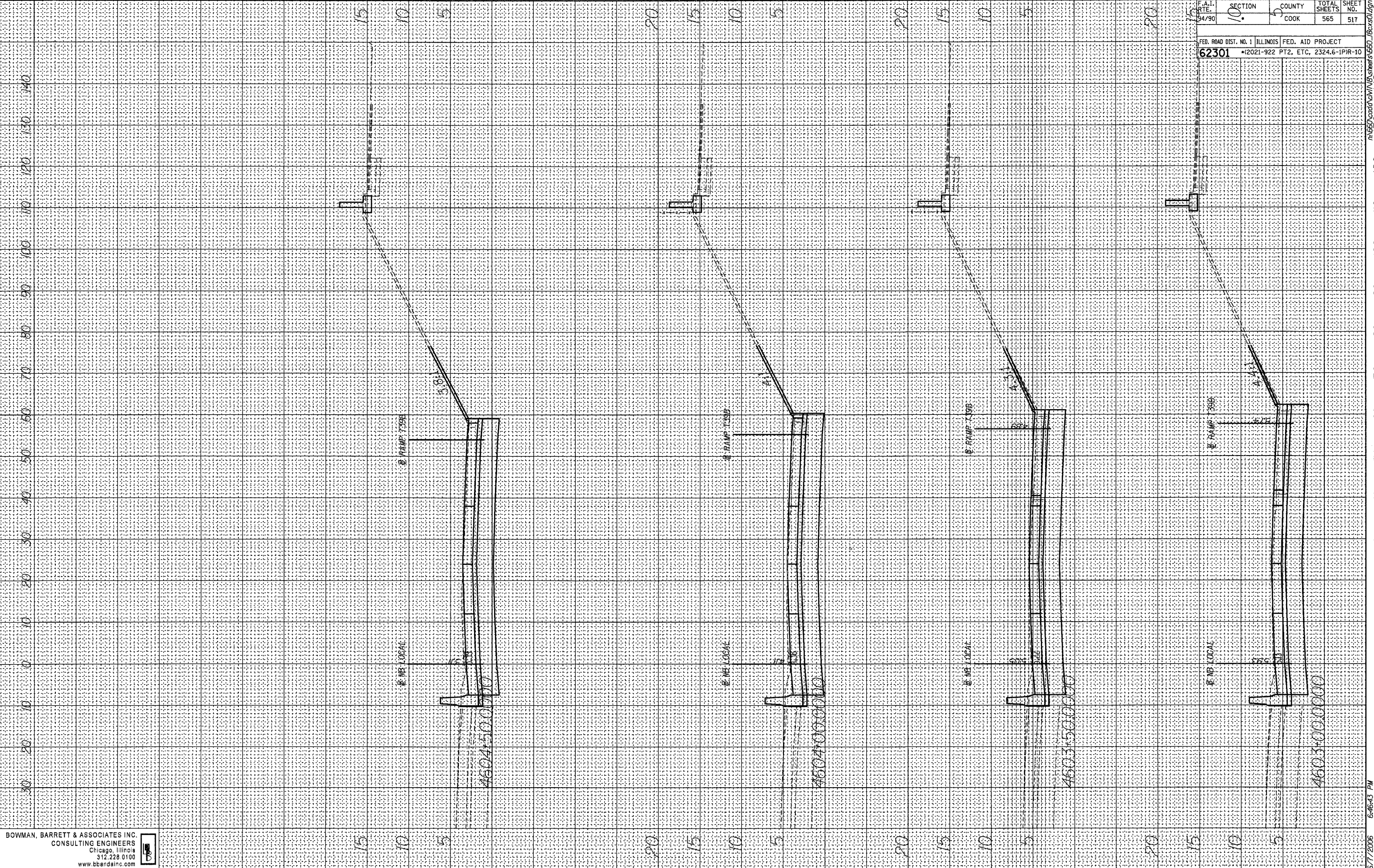

BOWMAN, BARRETT & ASSOCIATES INC.
 CONSULTING ENGINEERS
 Chicago, Illinois
 312.228.0100
 www.bbainc.com

F.A.I. RTE. 94/90	SECTION 10	COUNTY COOK	TOTAL SHEETS 565	SHEET NO. 517
FED. ROAD DIST. NO. 1 ILLINOIS		FED. AID PROJECT		
62301		*2021-922 PT2, ETC, 2324.6-1PIR-10		

6/7/2006 6:46:43 PM

FINAL SURVEY PLOTTED BY DATE
 SURVEYED BY
 NOTE BOOK NO.
 AREAS CHECKED

ORIGINAL SURVEY PLOTTED BY DATE
 SURVEYED BY
 NOTE BOOK NO.
 AREAS CHECKED

F.A.I. DATE 94/90	SECTION 10	COUNTY COOK	TOTAL SHEETS 565	SHEET NO. 518
FED. ROAD DIST. NO. 1 62301		ILLINOIS FED. AID PROJECT *2021-922 PT2, ETC, 2324.6-IPR-10		

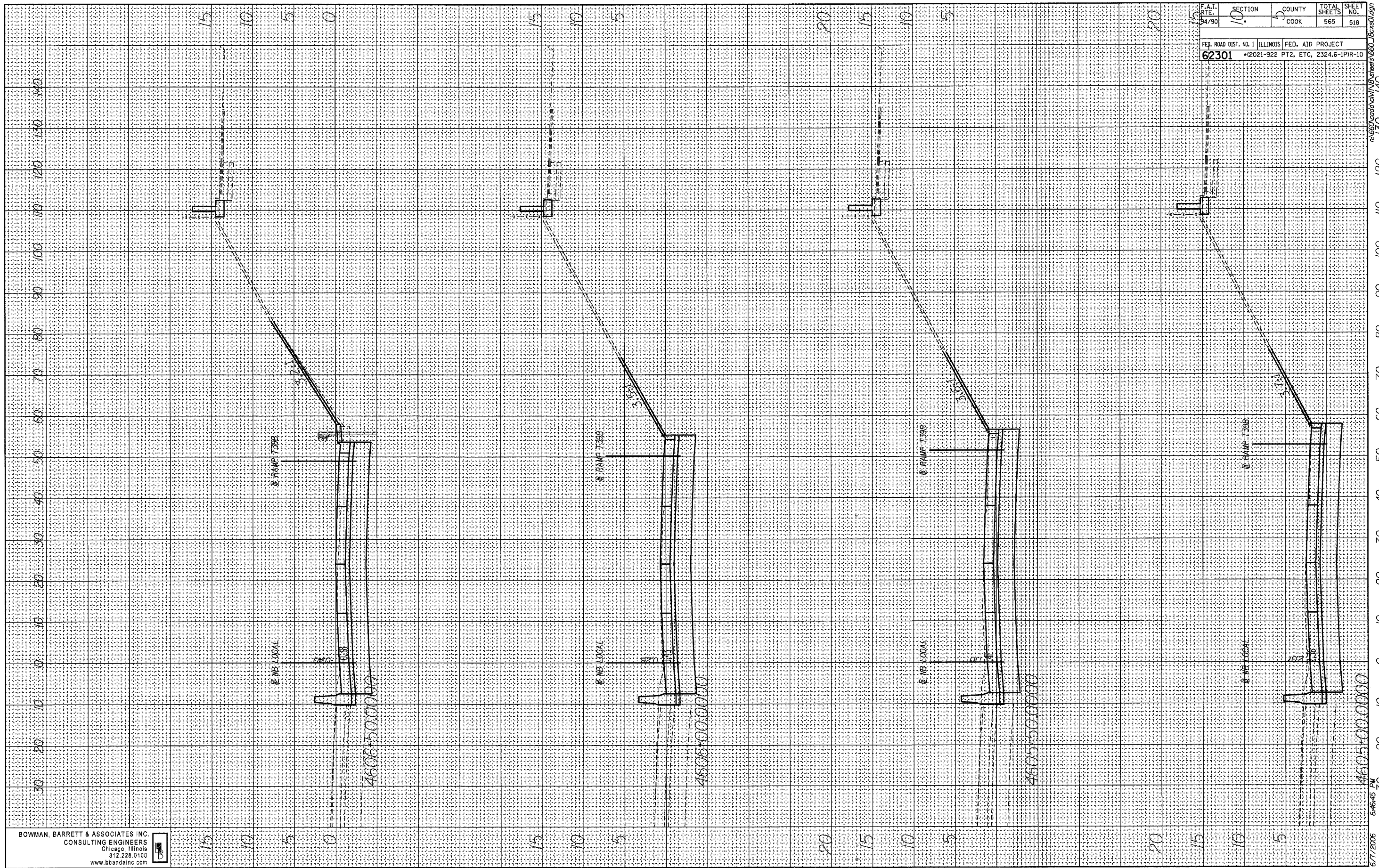

BOWMAN, BARRETT & ASSOCIATES INC.
 CONSULTING ENGINEERS
 Chicago, Illinois
 312.228.0100
 www.bbainc.com



6/7/2006 6:46:45 PM
 m:\62301\cadd\cadd\IPR\Sheet518.dwg

BY: _____ DATE: _____
 SURVEYED _____
 PLOTTED _____
 NOTE BOOK _____
 AREAS CHECKED _____

BY: _____ DATE: _____
 SURVEYED _____
 PLOTTED _____
 NOTE BOOK _____
 AREAS CHECKED _____

F.A.I. RTE. 94/90	SECTION •	COUNTY COOK	TOTAL SHEETS 565	SHEET NO. 519
FED. ROAD DIST. NO. 1 ILLINOIS FED. AID PROJECT 62301 •(2021-922 PT2, ETC, 2324.6-1P1R-10				

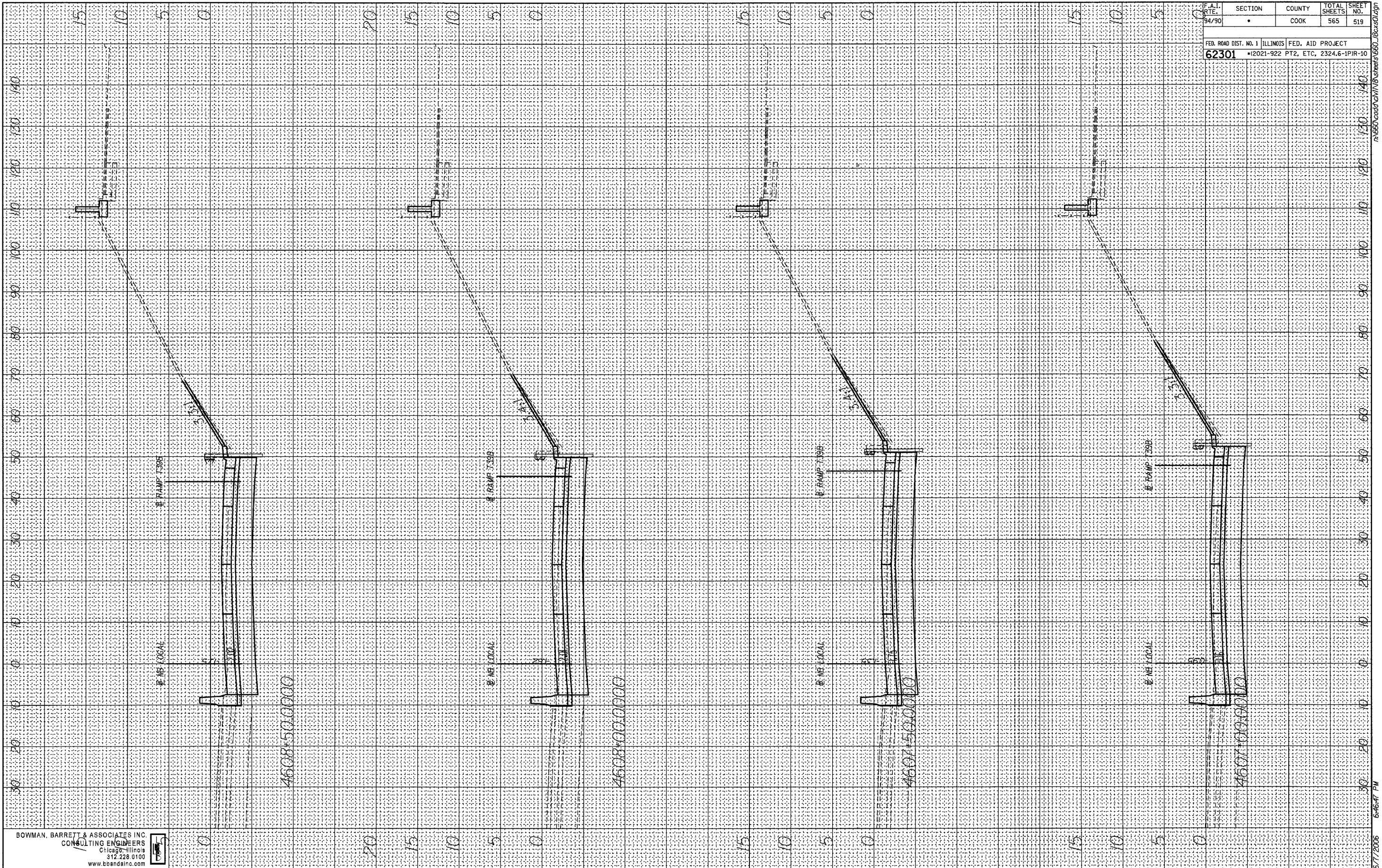

BOWMAN, BARRETT & ASSOCIATES INC.
 CONSULTING ENGINEERS
 Chicago, Illinois
 312.228.0100
 www.bbainc.com



6/7/2006 6:46:47 PM

FINAL SURVEY BY DATE
 SURVEYED BY
 TEMPLATE NO.
 NOTE BOOK NO.
 AREAS CHECKED

ORIGINAL SURVEY BY DATE
 SURVEYED BY
 TEMPLATE NO.
 NOTE BOOK NO.
 AREAS CHECKED

F.A.I. RTE. 94/90	SECTION •	COUNTY COOK	TOTAL SHEETS 565	SHEET NO. 520
FED. ROAD DIST. NO. 1 ILLINOIS		FED. AID PROJECT		
62301		*12021-922 PT2, ETC, 2324.6-1PIR-10		

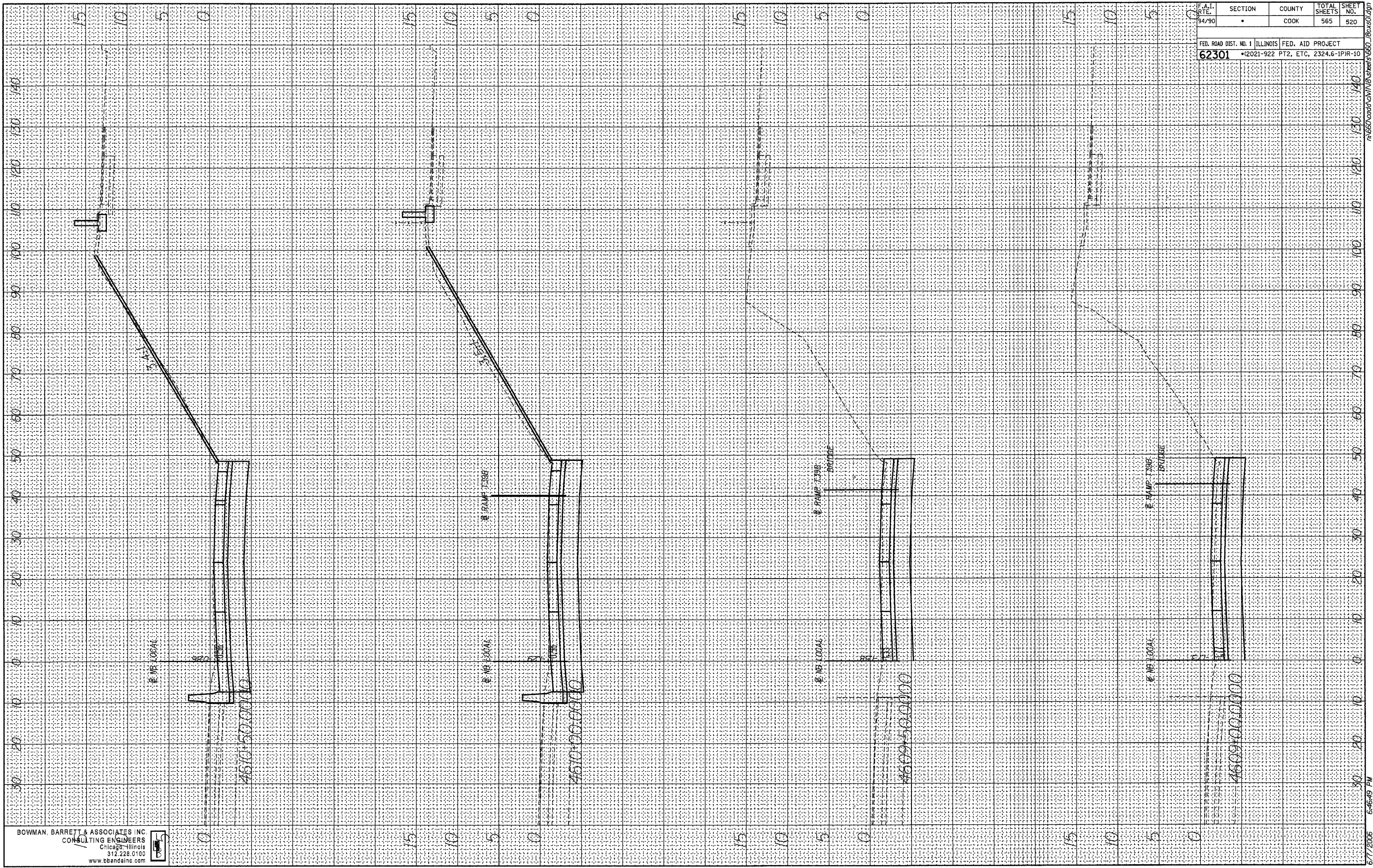

BOWMAN, BARRETT & ASSOCIATES INC.
 CONSULTING ENGINEERS
 Chicago, Illinois
 312.228.0100
 www.bbainc.com

6/7/2006 6:46:49 PM

\\660.cad\CAD\IN\B\Streams\660_1Box501.dwg

FINAL SURVEY
 SURVEYED BY _____ DATE _____
 NOTE BOOK NO. _____
 TEMPLATE AREA'S CHECKED _____

ORIGINAL SURVEY
 SURVEYED BY _____ DATE _____
 NOTE BOOK NO. _____
 TEMPLATE AREA'S CHECKED _____

F.A.T. RTE. 94/90	SECTION 4	COUNTY COOK	TOTAL SHEETS 565	SHEET NO. 521
FED. ROAD DIST. NO. 1		ILLINOIS		FED. AID PROJECT
62301		•(2021-922 PT2, ETC, 2324.6-1PIR-10		

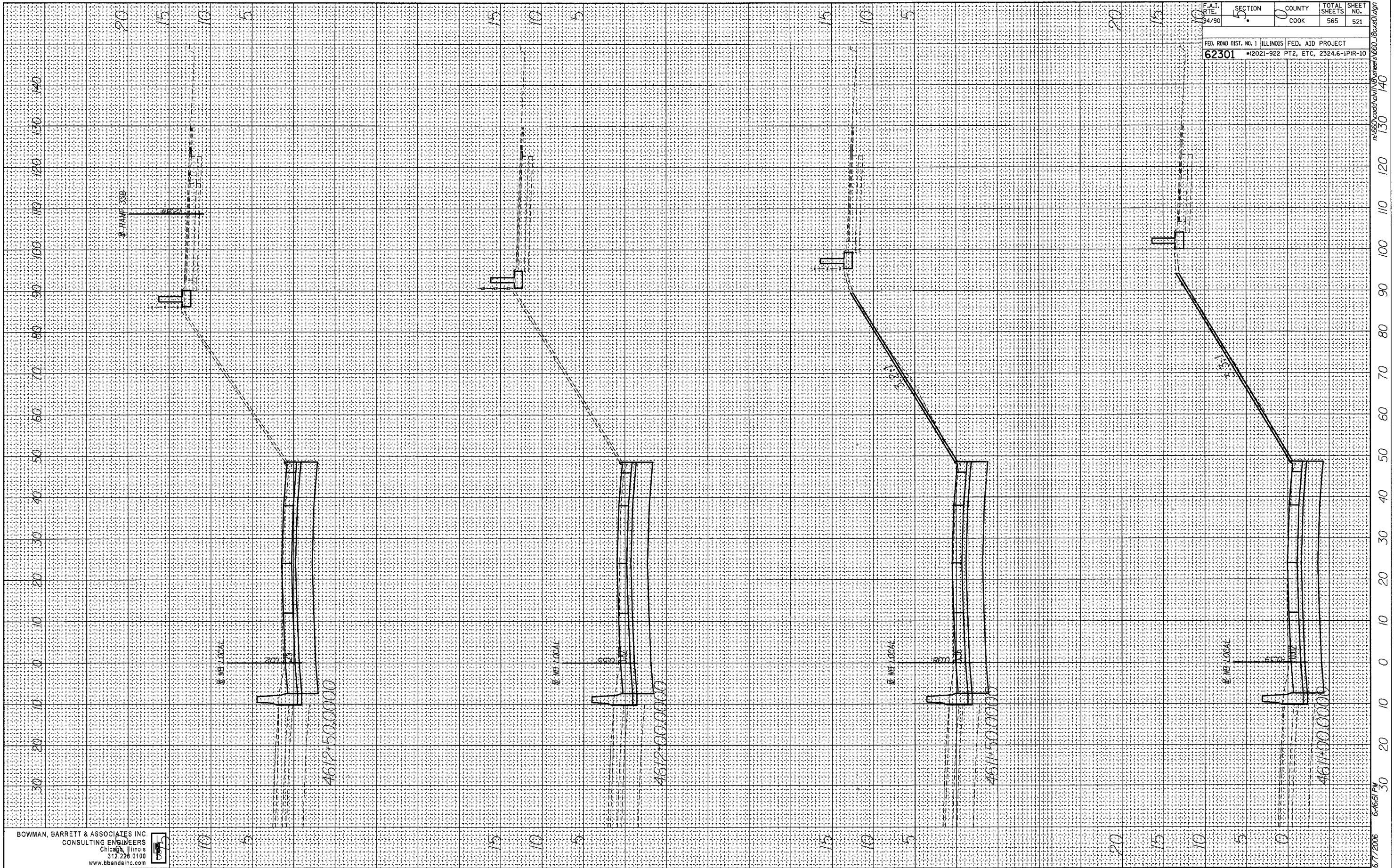

BOWMAN, BARRETT & ASSOCIATES INC
 CONSULTING ENGINEERS
 Chicago, Illinois
 312.228.0100
 www.bbainc.com



6/7/2006 6:46:51 PM

FINAL SURVEY BY DATE
 SURVEYED BY
 TEMPLATE
 AREAS CHECKED

ORIGINAL SURVEY BY DATE
 SURVEYED BY
 TEMPLATE
 AREAS CHECKED

F.A.T. RTE. 94/90	SECTION 4	COUNTY COOK	TOTAL SHEETS 565	SHEET NO. 522
FED. ROAD DIST. NO. 1		ILLINOIS		FED. AID PROJECT
62301		*(2021-922 PT2, ETC, 2324.6-1PIR-10		

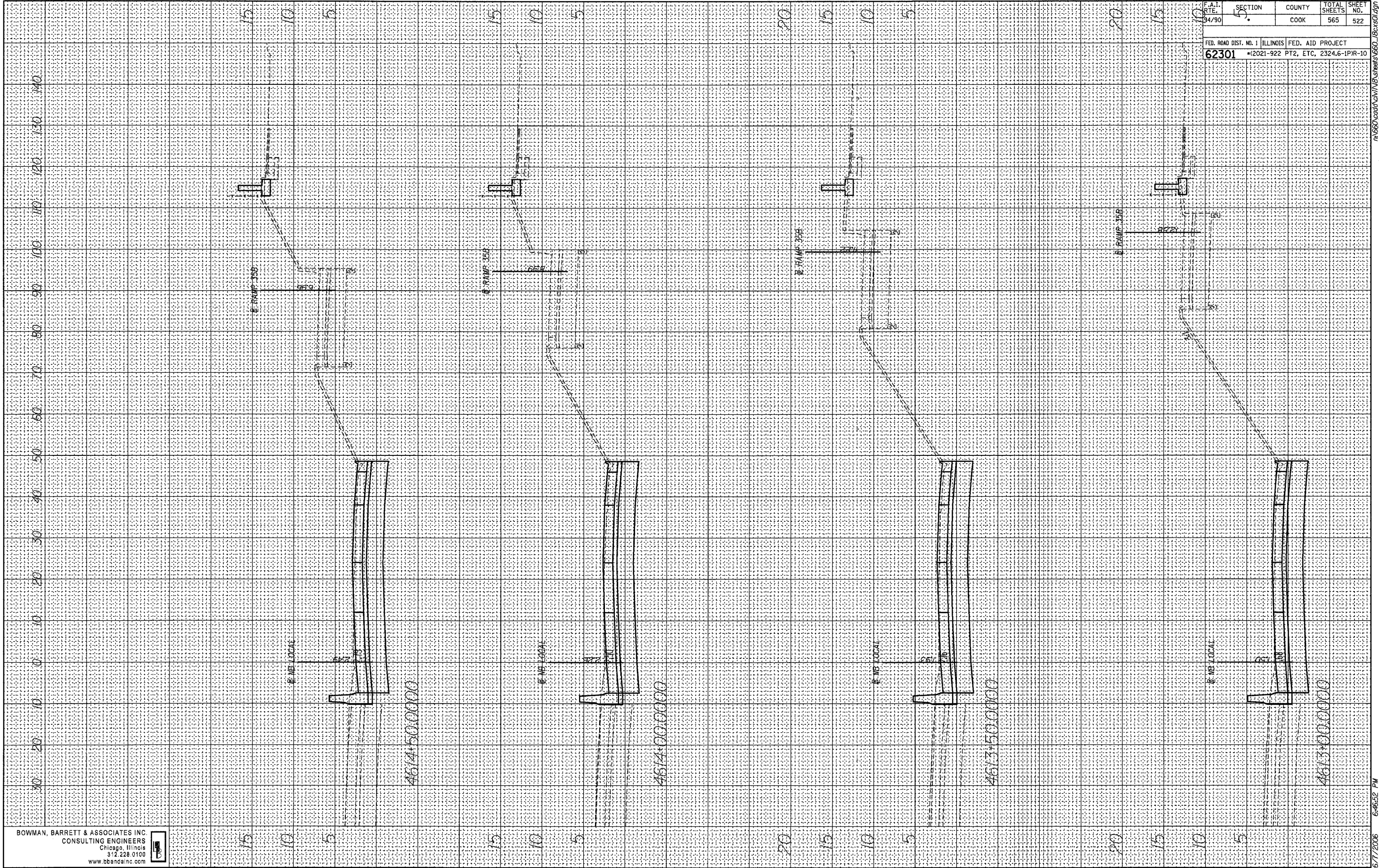

BOWMAN, BARRETT & ASSOCIATES INC.
 CONSULTING ENGINEERS
 Chicago, Illinois
 312.228.0100
 www.bbainc.com



6/7/2006 6:46:52 PM

ORIGINAL SURVEY PLOTTED DATE
 SURVEY PLOTTED DATE
 NOTE BOOK NO.
 AREAS CHECKED

ORIGINAL SURVEY PLOTTED DATE
 SURVEY PLOTTED DATE
 NOTE BOOK NO.
 AREAS CHECKED

F.A.I. RT. 94/90	SECTION	COUNTY COOK	TOTAL SHEETS 565	SHEET NO. 523
FED. ROAD DIST. NO. 1 ILLINOIS FED. AID PROJECT				
62301 (2021-922 PT2, ETC. 2324.6-IPR-10				

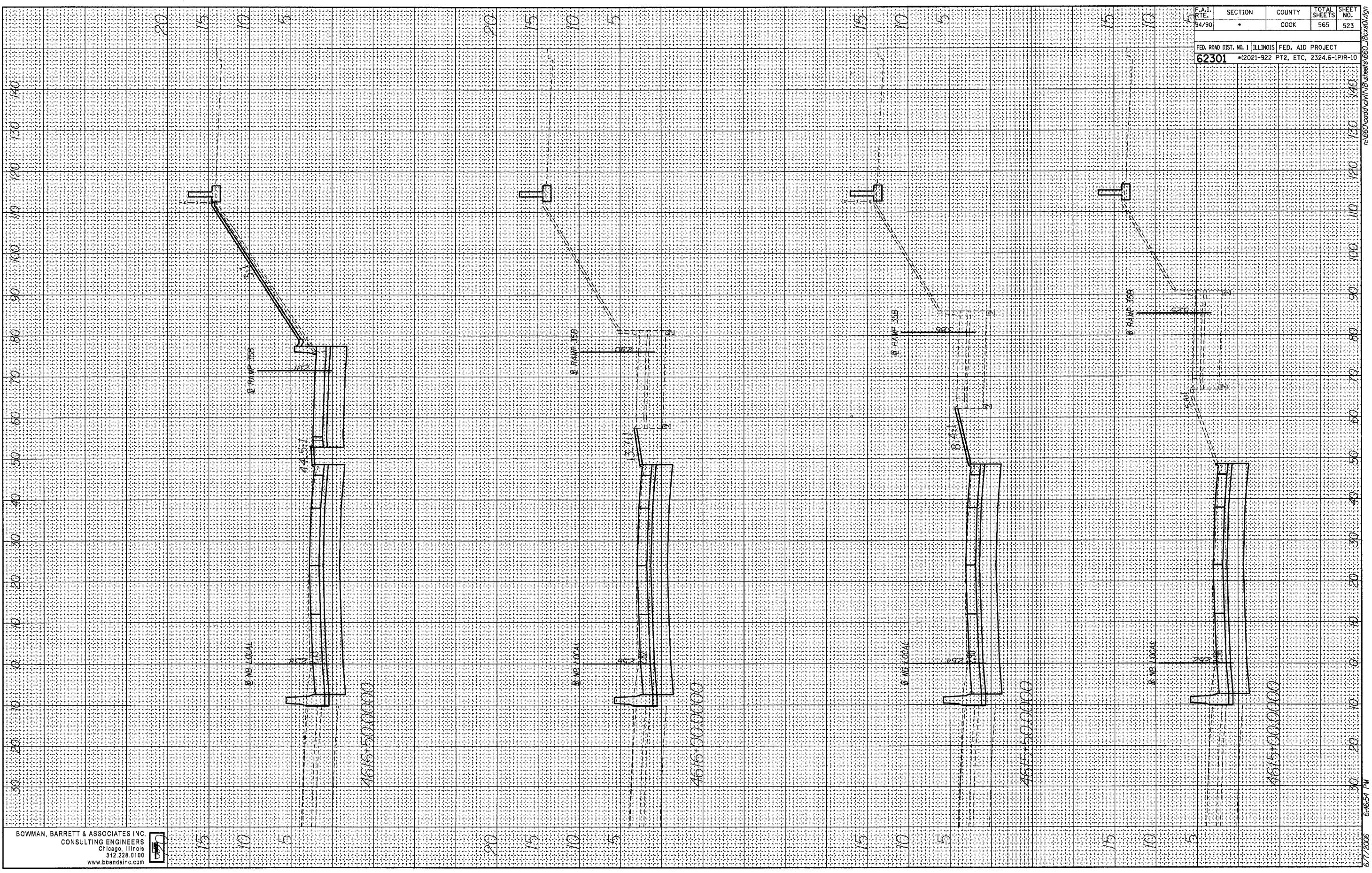

BOWMAN, BARRETT & ASSOCIATES INC.
 CONSULTING ENGINEERS
 Chicago, Illinois
 312.228.0100
 www.bbanda.com



6/7/2006 6:46:54 PM
 T:\660\road\ch\1\B\Sheets\660_7Bx60.dgn

FINAL SURVEY
 SURVEYED BY
 NOTE BOOK NO.
 TEMPLATE AREAS CHECKED

ORIGINAL SURVEY
 SURVEYED BY
 NOTE BOOK NO.
 TEMPLATE AREAS CHECKED

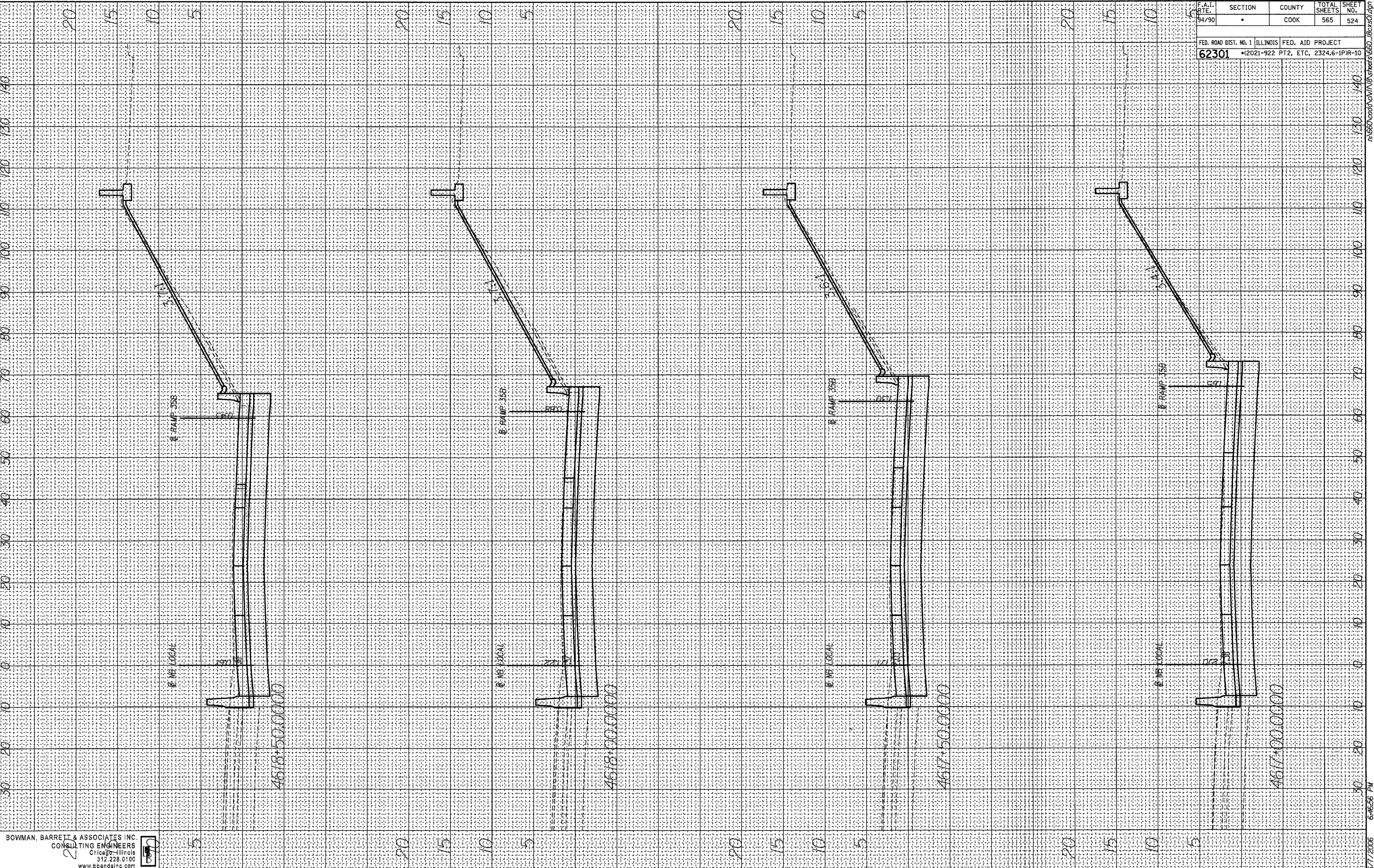

F.A.T. RTE.	SECTION	COUNTY	TOTAL SHEETS	SHEET NO.
94/90	*	COOK	565	524
FED. ROAD DIST. NO. 1 ILLINOIS FED. AID PROJECT				
62301 *12021-922 PT2, ETC, 2324.6-1PIR-10				

BOWMAN, BARRETT & ASSOCIATES INC
 CONSULTING ENGINEERS
 Chicago - Illinois
 312.228.0100
 www.bbainc.com



6/7/2006 6:46:56 PM

FINAL SURVEY BY DATE
 SURVEYED BY
 PLOTTED BY
 NOTE BOOK NO.
 DATE
 AREAS CHECKED

ORIGINAL SURVEY BY DATE
 SURVEYED BY
 PLOTTED BY
 NOTE BOOK NO.
 DATE
 AREAS CHECKED

F.A.I. RTE.	SECTION	COUNTY	TOTAL SHEETS	SHEET NO.
94/90	*	COOK	565	525
FED. ROAD DIST. NO. 1		ILLINOIS		FED. AID PROJECT
62301		*(2021-922 PT2, ETC, 2324.6-IPR-10		

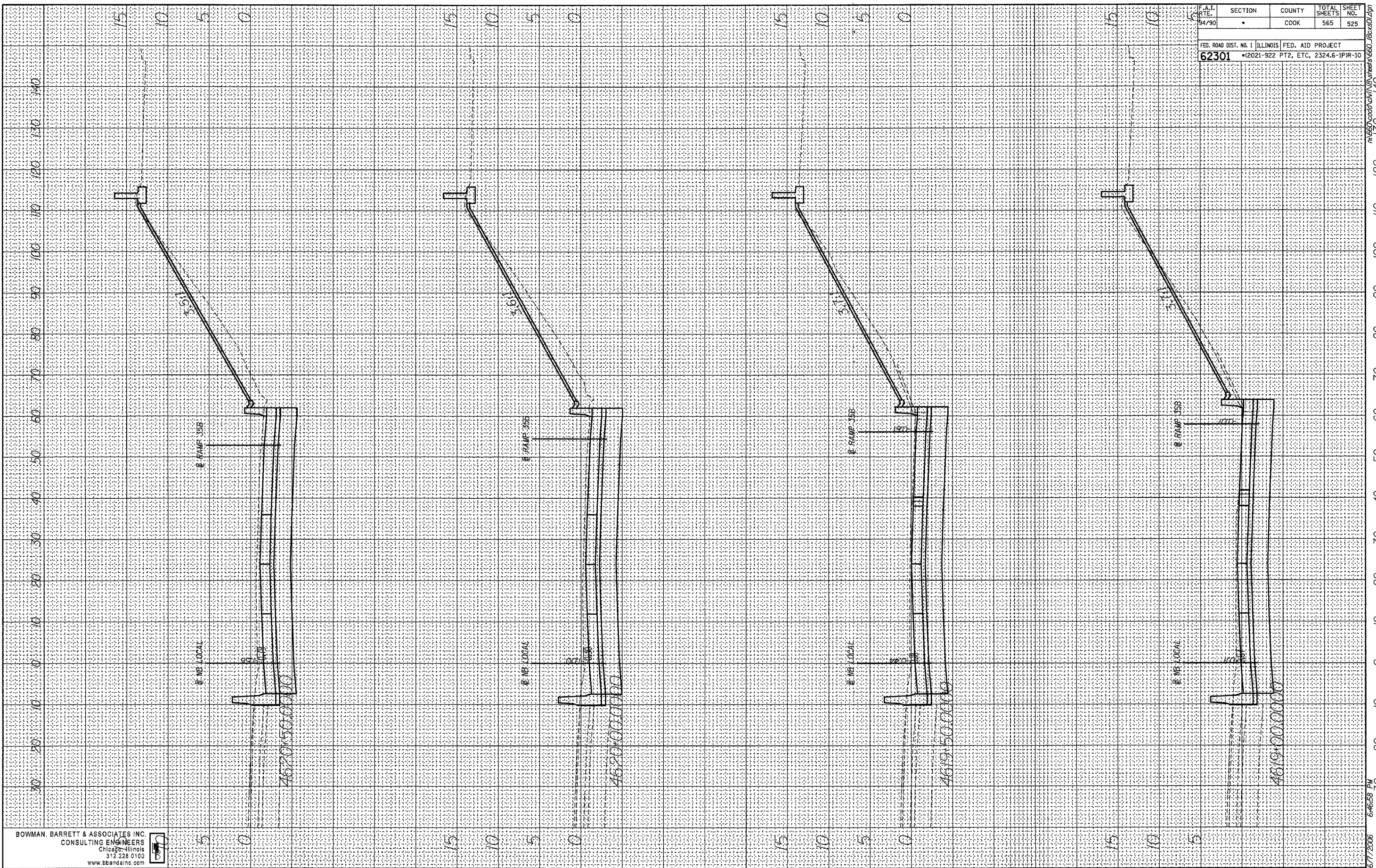

BOWMAN, BARRETT & ASSOCIATES INC.
 CONSULTING ENGINEERS
 Chicago, Illinois
 312.228.0100
 www.bbainc.com



6/7/2006 6:46:58 PM

FINAL SURVEY
 SURVEYED BY _____ DATE _____
 NOTE BOOK NO. _____
 TEMPLATE AREAS CHECKED _____

ORIGINAL SURVEY
 SURVEYED BY _____ DATE _____
 NOTE BOOK NO. _____
 TEMPLATE AREAS CHECKED _____

F.A.T. RTE. 94/90	SECTION 0	COUNTY COOK	TOTAL SHEETS 565	SHEET NO. 526
FED. ROAD DIST. NO. 1		ILLINOIS FED. AID PROJECT		
62301		*2021-922 PT2, ETC, 2324.6-1PIR-10		

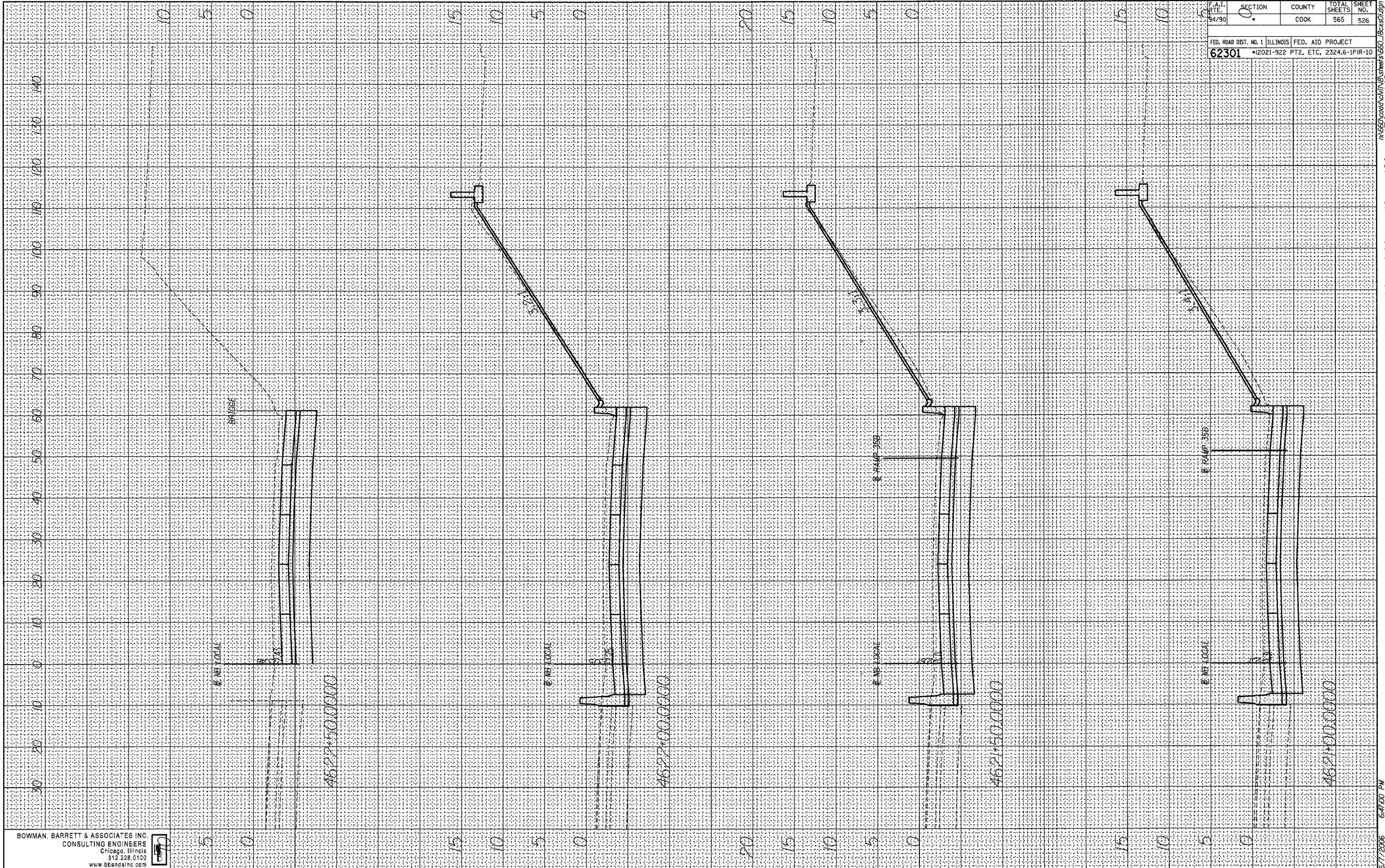

BOWMAN, BARRETT & ASSOCIATES INC.
 CONSULTING ENGINEERS
 Chicago, Illinois
 312.228.0100
 www.bbendinc.com



6/7/2006 6:47:00 PM
 n:\650\road\ch\1\18\sheet526.dwg

FINAL SURVEY BY DATE
 SURVEYED BY
 PLOTTED BY
 NOTE BOOK NO.
 DATE
 AREAS CHECKED

ORIGINAL SURVEY BY DATE
 SURVEYED BY
 PLOTTED BY
 NOTE BOOK NO.
 DATE
 AREAS CHECKED

F.A.I. RTE.	SECTION	COUNTY	TOTAL SHEETS	SHEET NO.
94/90	*	COOK	565	527

FED. ROAD DIST. NO. 1 ILLINOIS FED. AID PROJECT
62301 •(2021-922 PT2, ETC, 2324.6-IPR-10

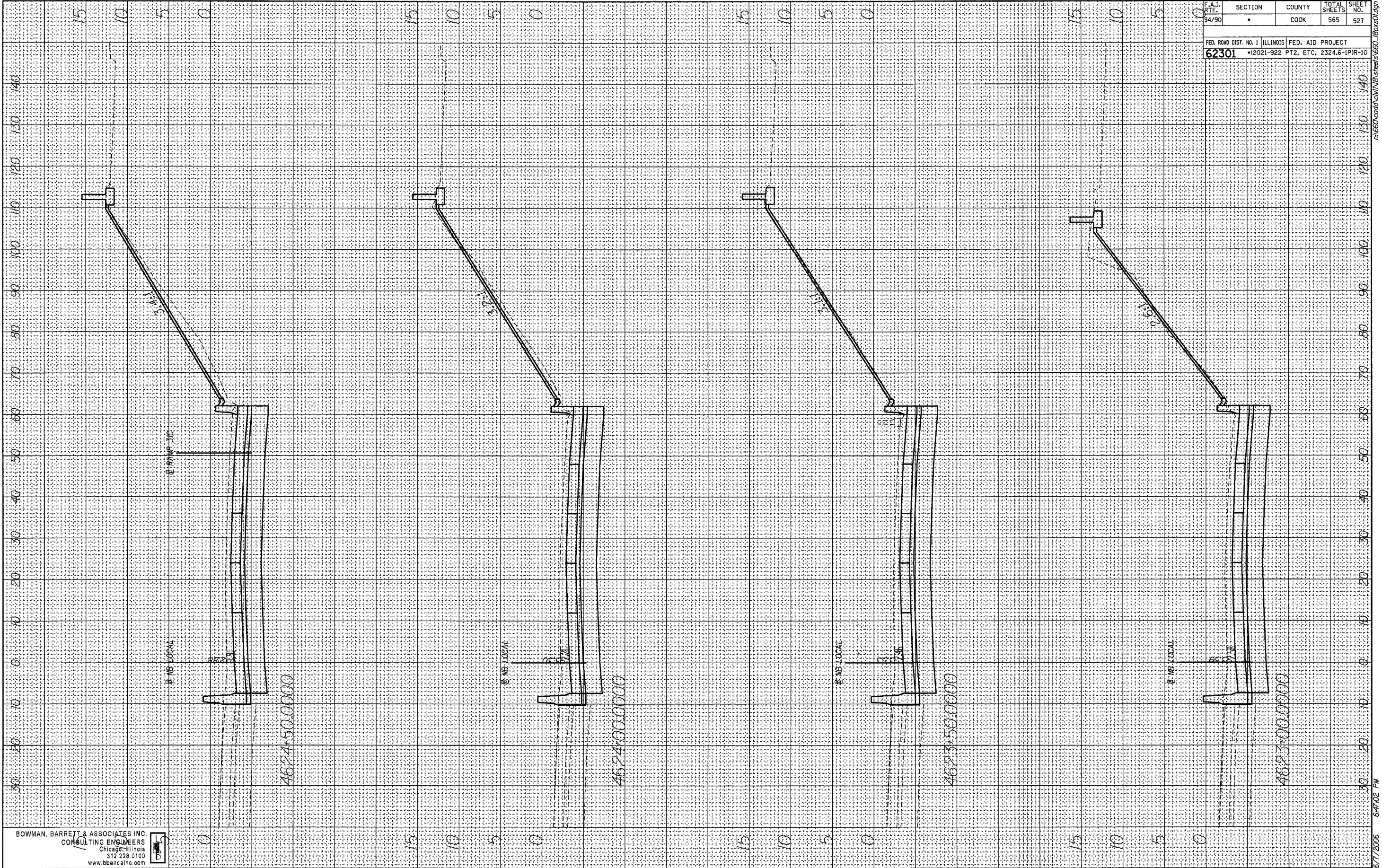

BOWMAN, BARRETT & ASSOCIATES INC.
 CONSULTING ENGINEERS
 Chicago, Illinois
 312.228.0100
 www.bbainc.com



6/7/2006 6:47:02 PM

FINAL SURVEY
 SURVEYED BY _____ DATE _____
 NOTE BOOK NO. _____
 TEMPLATE AREAS CHECKED _____

ORIGINAL SURVEY
 SURVEYED BY _____ DATE _____
 NOTE BOOK NO. _____
 TEMPLATE AREAS CHECKED _____

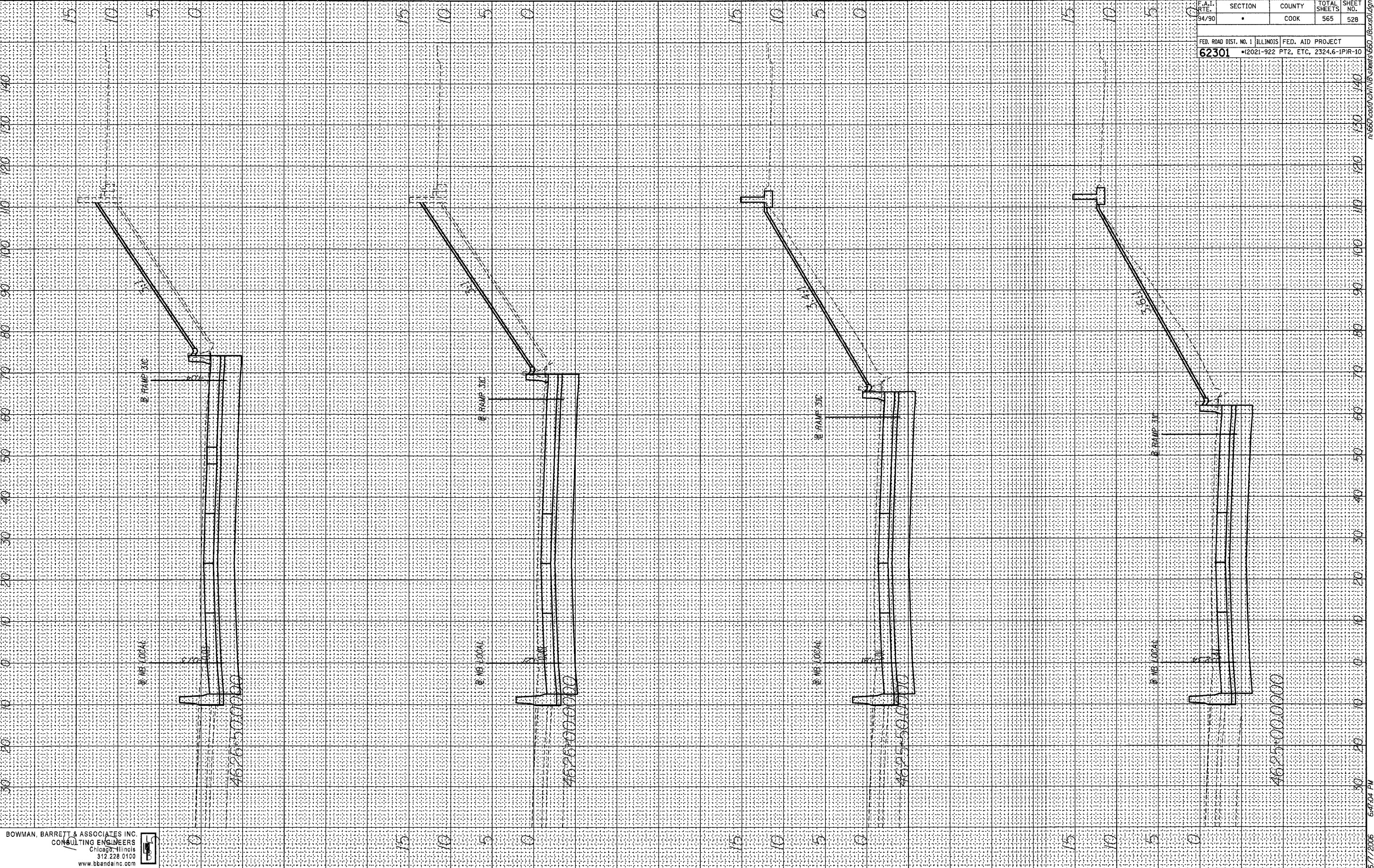

F.A.I. RTE.	SECTION	COUNTY	TOTAL SHEETS	SHEET NO.
94/90	•	COOK	565	528

FED. ROAD DIST. NO. 1 ILLINOIS FED. AID PROJECT
62301 •(2021-922 PT2, ETC, 2324.6-1PIR-10

BOWMAN, BARRETT & ASSOCIATES INC.
 CONSULTING ENGINEERS
 Chicago, Illinois
 312.228.0100
 www.bbenda.com



6/7/2006 6:47:34 PM

BY	DATE
ORIGINAL SURVEY PLOTTED NOTE BOOK AREAS CHECKED	
NO.	
FINAL SURVEY PLOTTED NOTE BOOK AREAS CHECKED	
NO.	

BY	DATE
ORIGINAL SURVEY PLOTTED NOTE BOOK AREAS CHECKED	
NO.	
FINAL SURVEY PLOTTED NOTE BOOK AREAS CHECKED	
NO.	

F.A.I. RTE. 94/90	SECTION 5	COUNTY COOK	TOTAL SHEETS 565	SHEET NO. 529
----------------------	--------------	----------------	---------------------	------------------

FED. ROAD DIST. NO. 1 ILLINOIS FED. AID PROJECT
62301 •(2021-922 PT2, ETC, 2324.6-1P)R-10

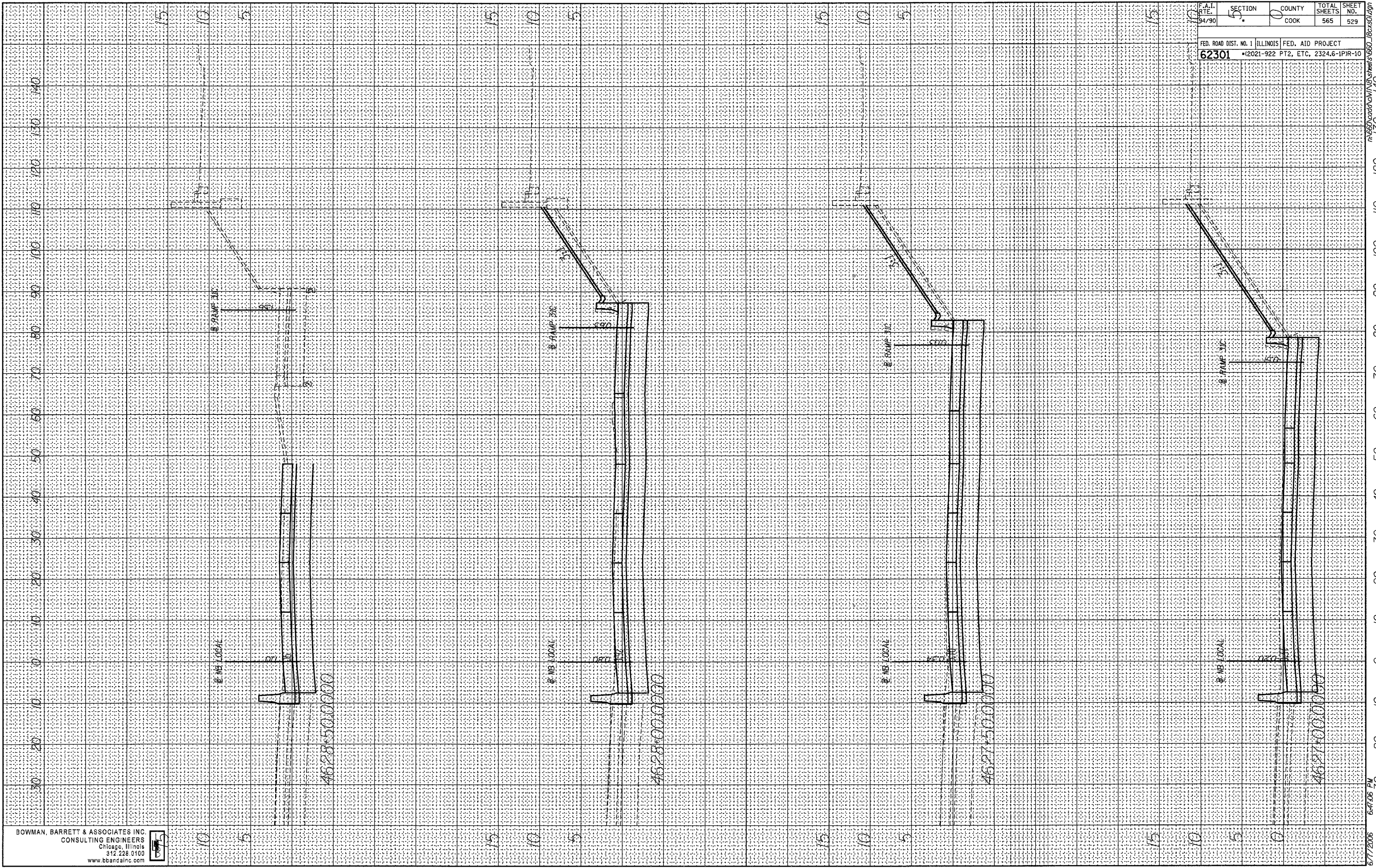

BOWMAN, BARRETT & ASSOCIATES INC.
CONSULTING ENGINEERS
Chicago, Illinois
312.228.0100
www.bbainc.com



8/7/2006 6:47:06 PM

n:\660\road\ch\10\10 sheets\660_10c2x60.dgn

ORIGINAL SURVEY	BY	DATE
PLOTTED		
NOTE BOOK NO.		
AREAS CHECKED		

FINAL SURVEY	BY	DATE
PLOTTED		
NOTE BOOK NO.		
AREAS CHECKED		

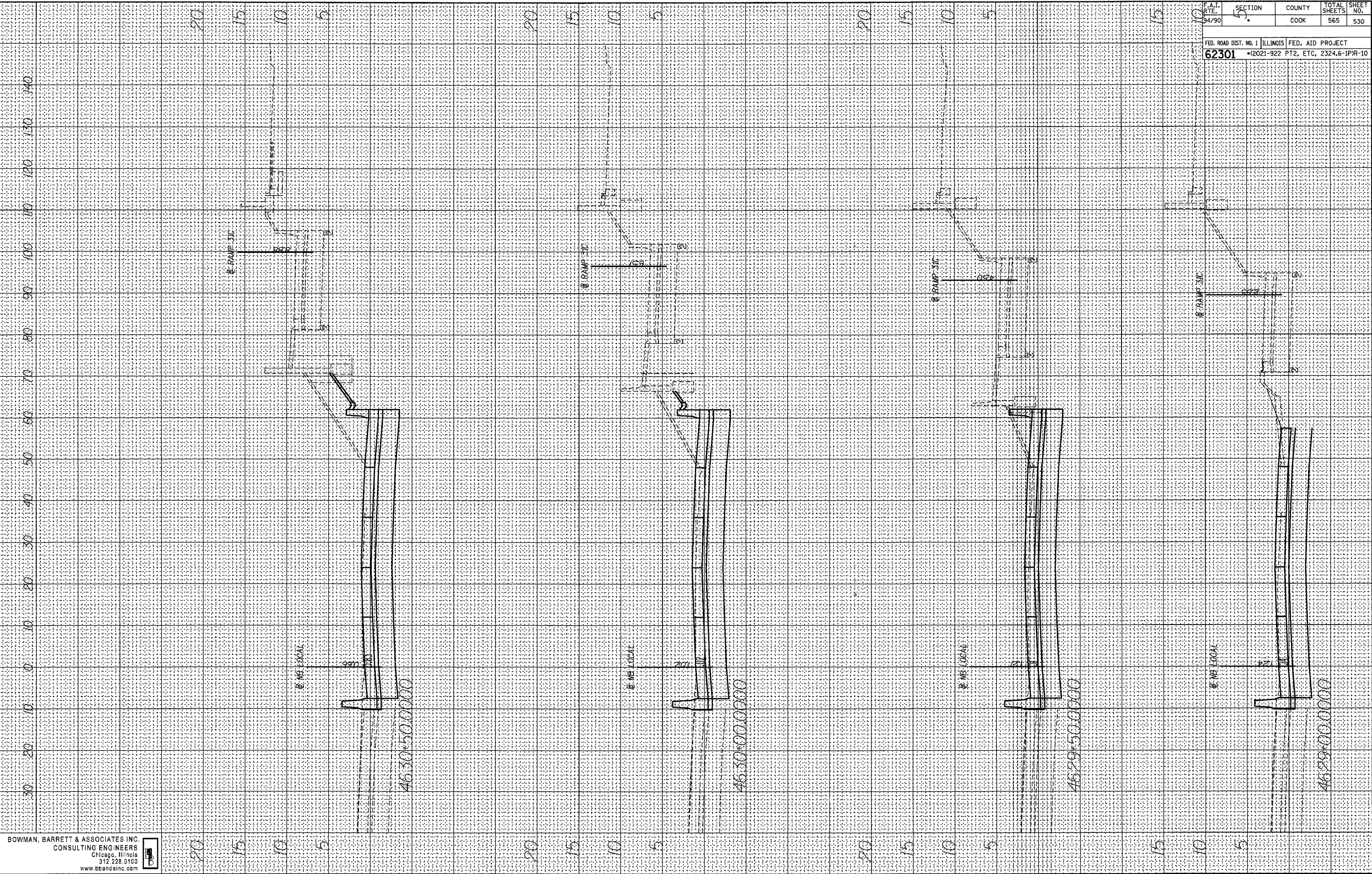

BOWMAN, BARRETT & ASSOCIATES INC.
CONSULTING ENGINEERS
Chicago, Illinois
312.228.0400
www.bbainc.com



F.A.T. RTE.	SECTION	COUNTY	TOTAL SHEETS	SHEET NO.
94/90	5	COOK	565	530
FED. ROAD DIST. NO. 1		ILLINOIS	FED. AID PROJECT	
62301			*(2021-922 PT2, ETC, 2324.6-1PR-10)	

6/7/2006 6:47:08 PM

FINAL SURVEY BY DATE
 SURVEYED BY
 PLOTTED BY
 NOTE BOOK NO.
 AREAS CHECKED

ORIGINAL SURVEY BY DATE
 SURVEYED BY
 PLOTTED BY
 NOTE BOOK NO.
 AREAS CHECKED

F.A.T. RTE. 94/90	SECTION •	COUNTY COOK	TOTAL SHEETS 565	SHEET NO. 531
FED. ROAD DIST. NO. 1 62301		ILLINOIS FED. AID PROJECT •(2021-922 PT2, ETC, 2324.6-1PR-10		

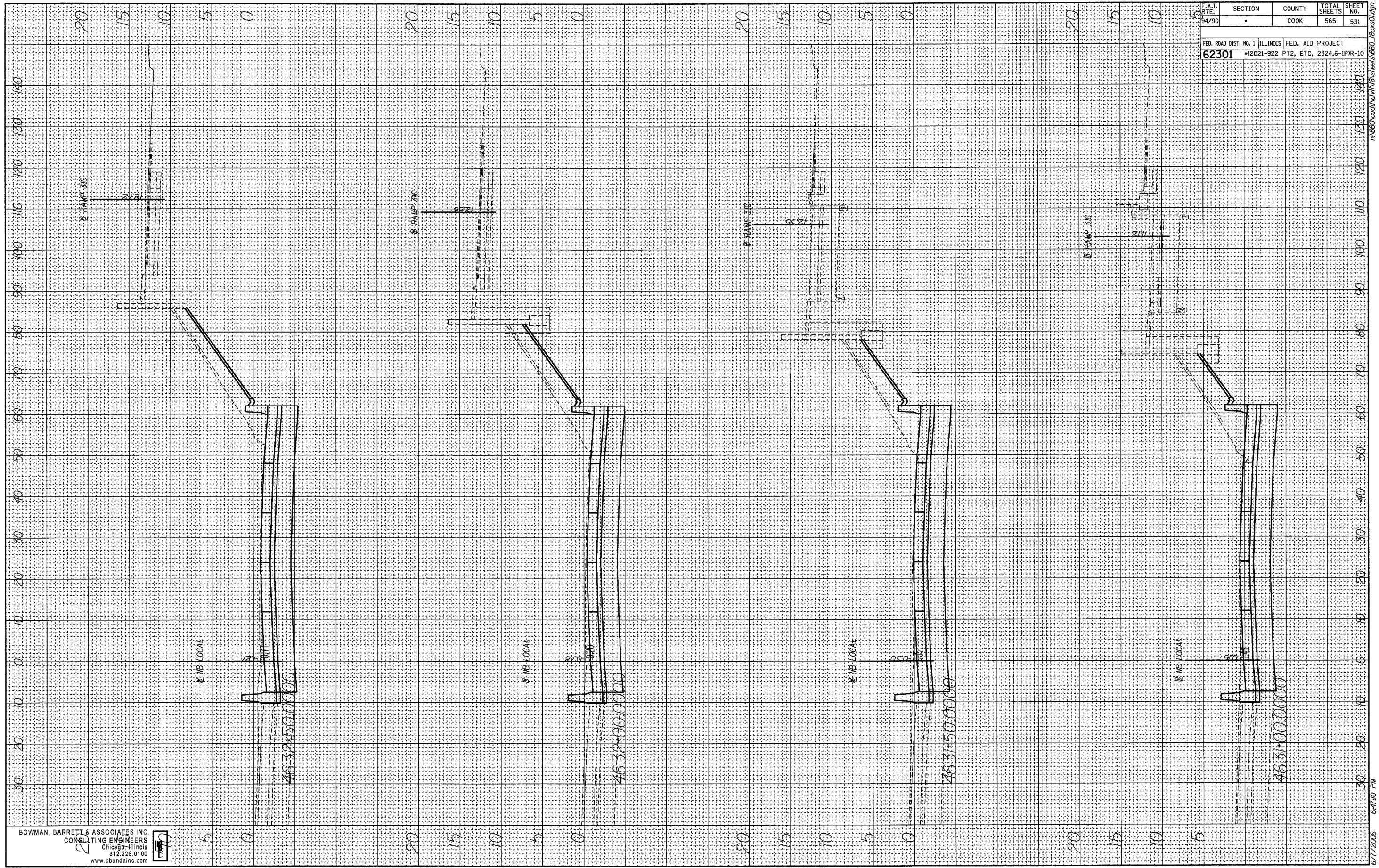

BOWMAN, BARRETT & ASSOCIATES INC
 CONSULTING ENGINEERS
 Chicago, Illinois
 312.228.0100
 www.bbainc.com



6/7/2006 6:47:10 PM

T:\660\card\cal\MB\Sheets\660_18cxs01.dgn

FINAL SURVEY
 SURVEYED BY
 NOTE BOOK NO.
 TEMPLATE AREAS CHECKED

ORIGINAL SURVEY
 SURVEYED BY
 NOTE BOOK NO.
 TEMPLATE AREAS CHECKED

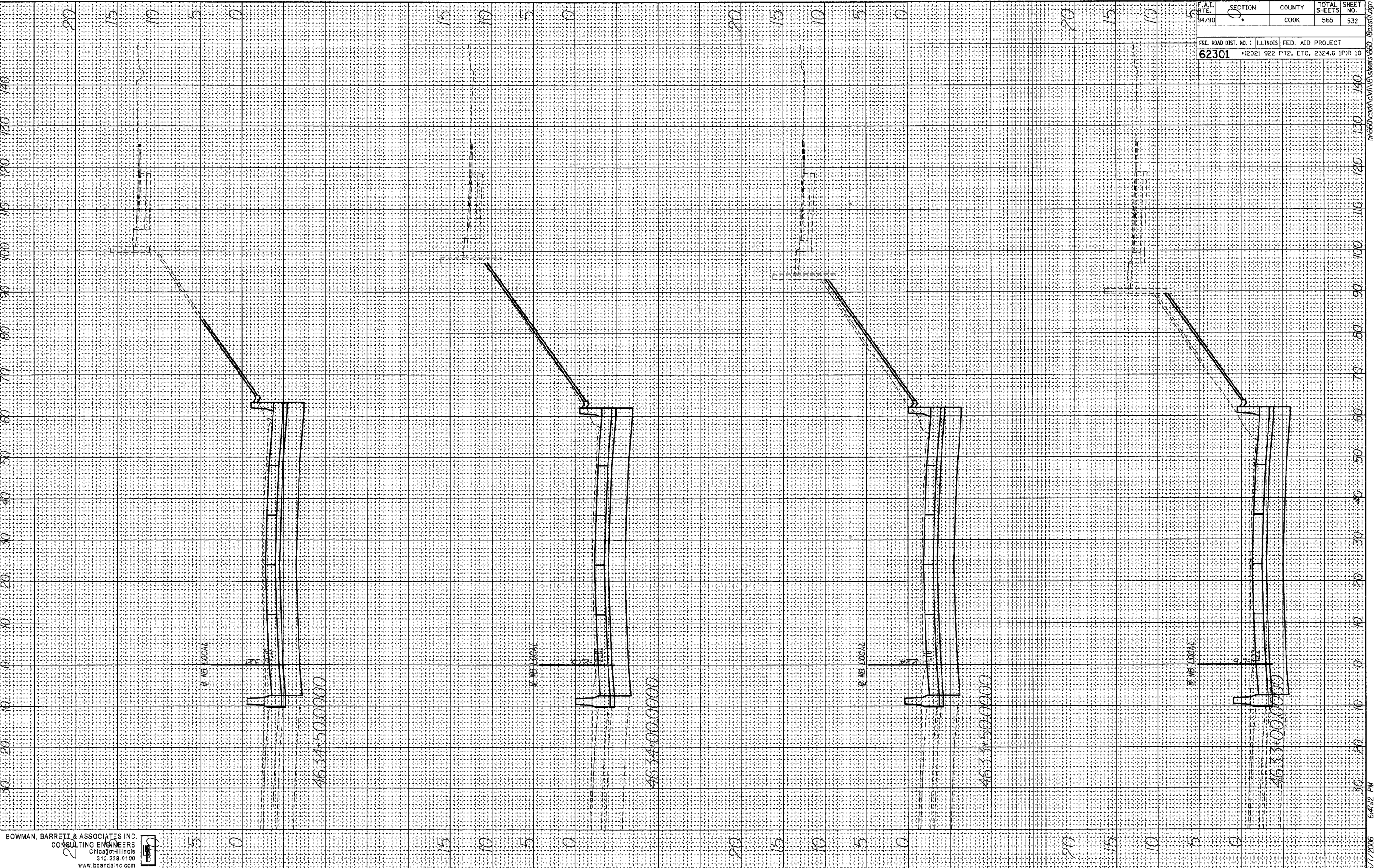

F.A.T. RTE.	SECTION	COUNTY	TOTAL SHEETS	SHEET NO.
94/90	0	COOK	565	532

FED. ROAD DIST. NO. 1 ILLINOIS FED. AID PROJECT
62301 •(2021-922 PT2, ETC, 2324.6-1PIR-10

BOWMAN, BARRETT & ASSOCIATES INC.
 CONSULTING ENGINEERS
 Chicago, Illinois
 312.228.0100
 www.bbandainc.com

6/7/2006 6:47:12 PM

FINAL SURVEY
 SURVEYED _____
 PLOTTED _____
 NOTE BOOK _____
 DATE _____
 AREAS CHECKED _____
 NO. _____

ORIGINAL SURVEY
 SURVEYED _____
 PLOTTED _____
 NOTE BOOK _____
 DATE _____
 AREAS CHECKED _____
 NO. _____

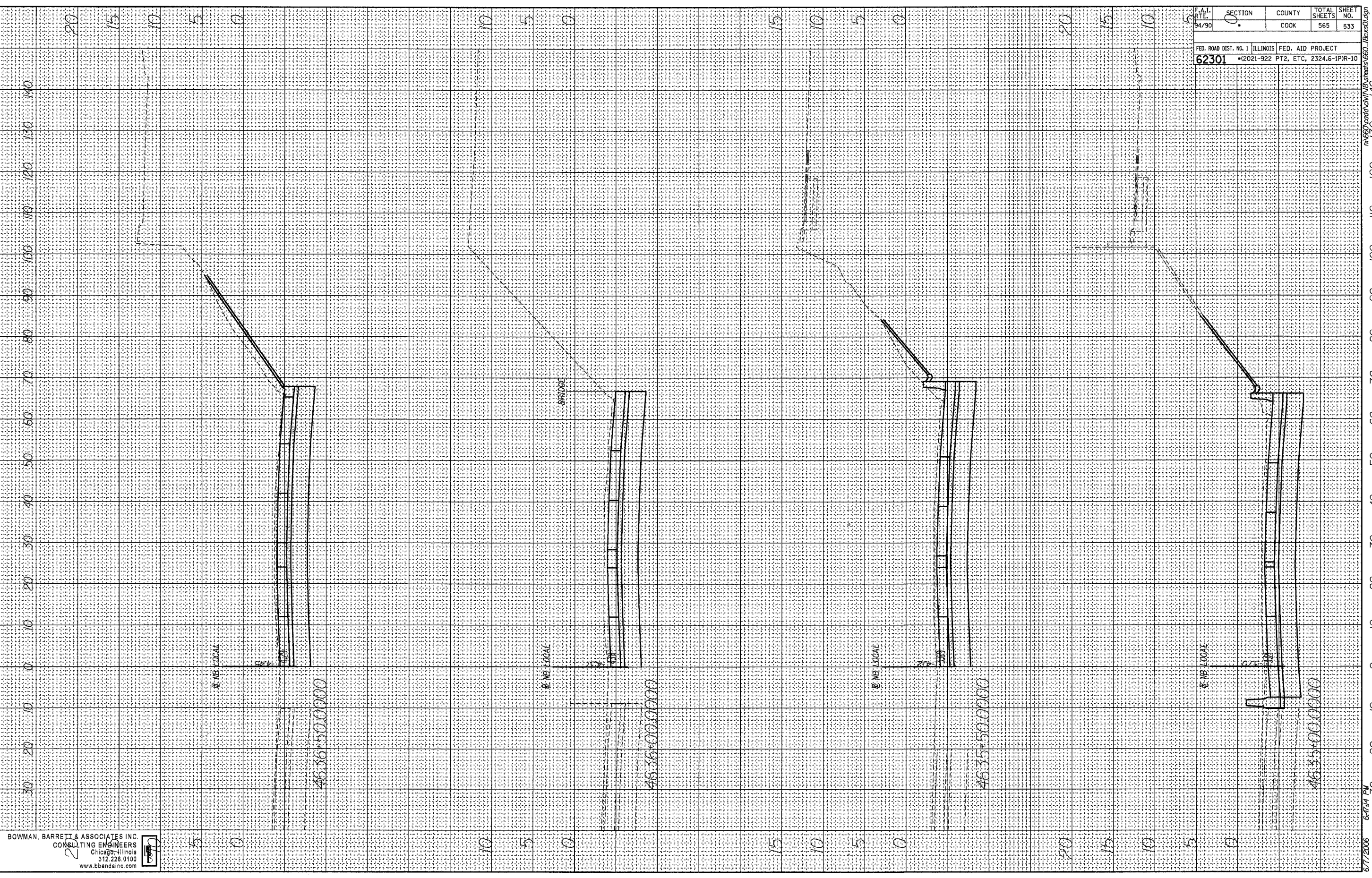

BOWMAN, BARRETT & ASSOCIATES INC.
 CONSULTING ENGINEERS
 Chicago, Illinois
 312.228.0100
 www.bbainc.com



F.A.I. R.T.E.	SECTION	COUNTY	TOTAL SHEETS	SHEET NO.
94/90	0	COOK	565	533
FED. ROAD DIST. NO. 1 ILLINOIS		FED. AID PROJECT		
62301		•(2021-922 PT2, ETC, 2324.6-1P1R-10		

6/7/2006 6:47:14 PM

ORIGINAL SURVEY
 SURVEYED _____
 PLOTTED _____
 NOTE BOOK _____
 NO. _____
 AREAS CHECKED _____

FINAL SURVEY
 SURVEYED _____
 PLOTTED _____
 NOTE BOOK _____
 NO. _____
 AREAS CHECKED _____

BY _____ DATE _____

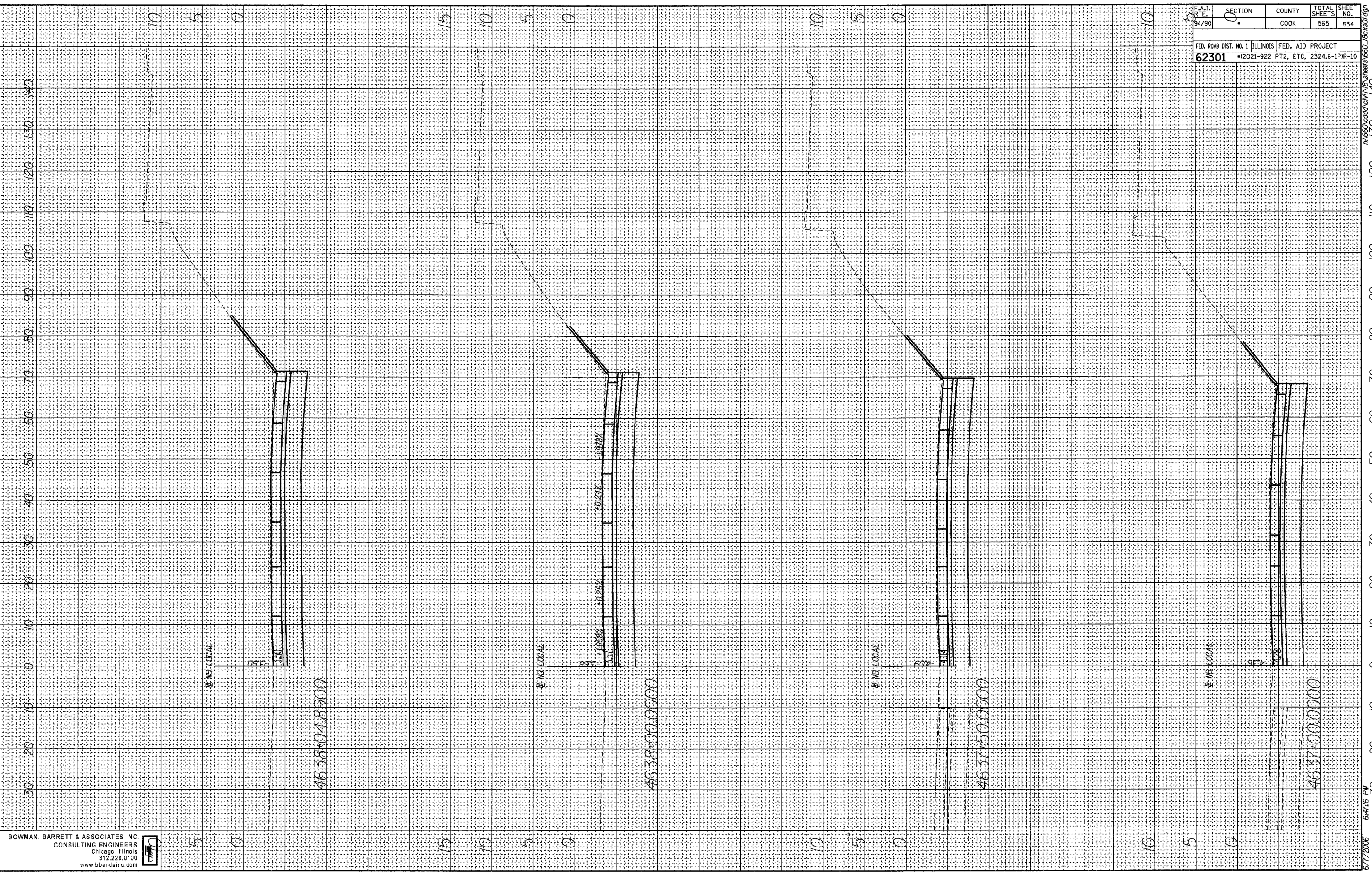

BOWMAN, BARRETT & ASSOCIATES INC.
 CONSULTING ENGINEERS
 Chicago, Illinois
 312.228.0100
 www.bbainc.com



F.A.I. RATE	SECTION	COUNTY	TOTAL SHEETS	SHEET NO.
34/90	0	COOK	565	534
FED. ROAD DIST. NO. 1 ILLINOIS FED. AID PROJECT				
62301 (2021-922 PT2, ETC, 2324.6-1PIR-10				

6/7/2006 6:47:16 PM
 m:\660\cadd\civil\en\sheet\660_18cvs01.dgn

FINAL SURVEY
 SURVEYED _____ BY _____ DATE _____
 PLOTTED _____
 NOTE BOOK _____
 AREAS CHECKED _____

ORIGINAL SURVEY
 SURVEYED _____ BY _____ DATE _____
 PLOTTED _____
 NOTE BOOK _____
 AREAS CHECKED _____

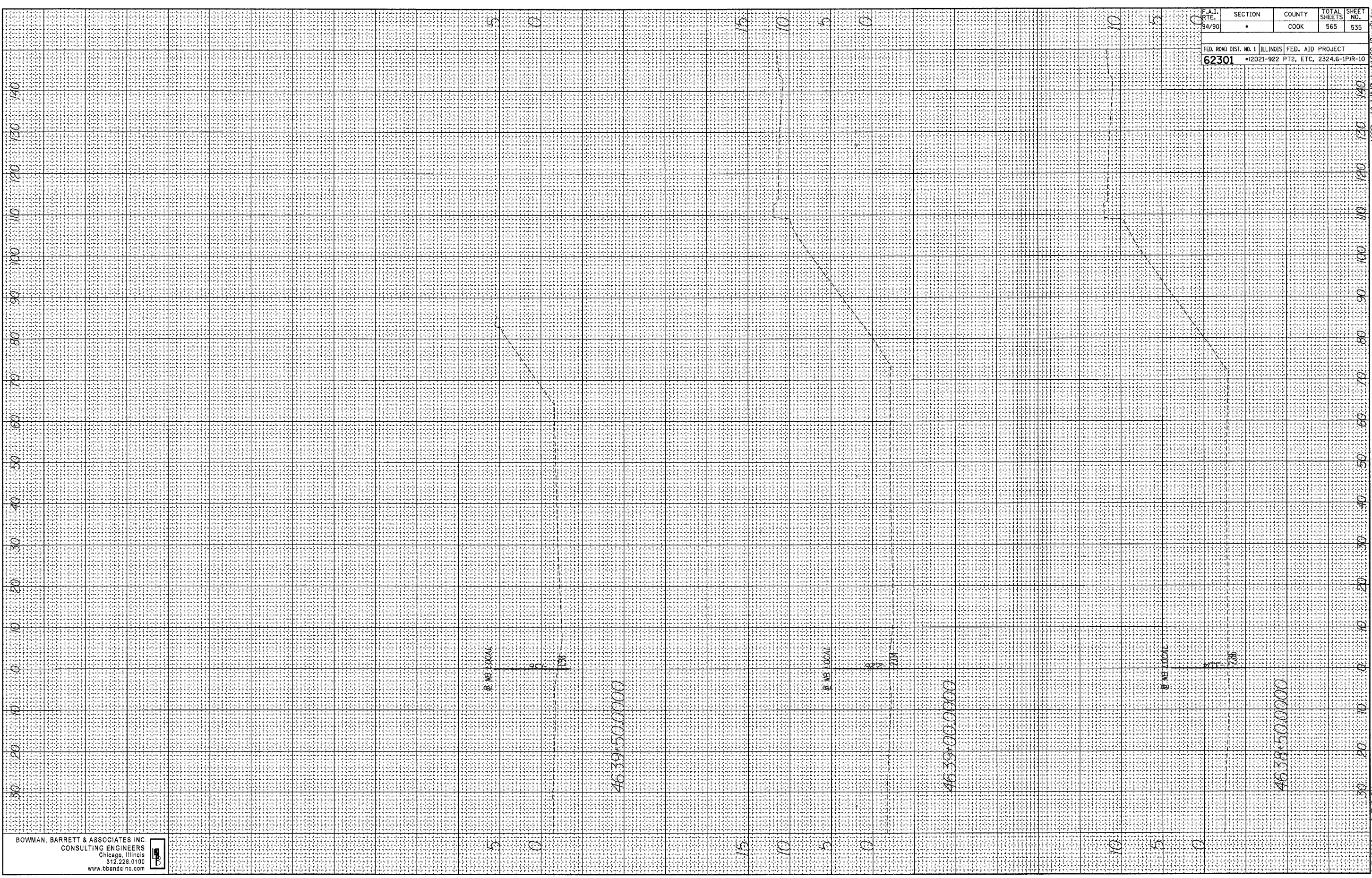

BOWMAN, BARRETT & ASSOCIATES INC
 CONSULTING ENGINEERS
 Chicago, Illinois
 312.228.0100
 www.bbainc.com



F.A.T. RTE. 94/90	SECTION •	COUNTY COOK	TOTAL SHEETS 565	SHEET NO. 535
FED. ROAD DIST. NO. 1 ILLINOIS FED. AID PROJECT				
62301 •(2021-922 PT2, ETC, 2324.6-1P1R-10				

In: 660\card\cal\WB\Sheets\660_18x30.dgn

6/7/2006 6:47:18 PM

F.A.I.	SECTION	COUNTY	TOTAL SHEETS	SHEET NO.
94/90	*	COOK	565	536
STA. 4530+00.00		TO STA. 4637+00.00		
FED. ROAD DIST. NO.		ILLINOIS	FED. AID PROJECT	

62301

PROFILE	SURVEYED	BY	DATE
NOTE BOOK NO.	PLOTTED		
NO.	REVISION		
	STRUCTURE NOTATIONS		
	CHFD		

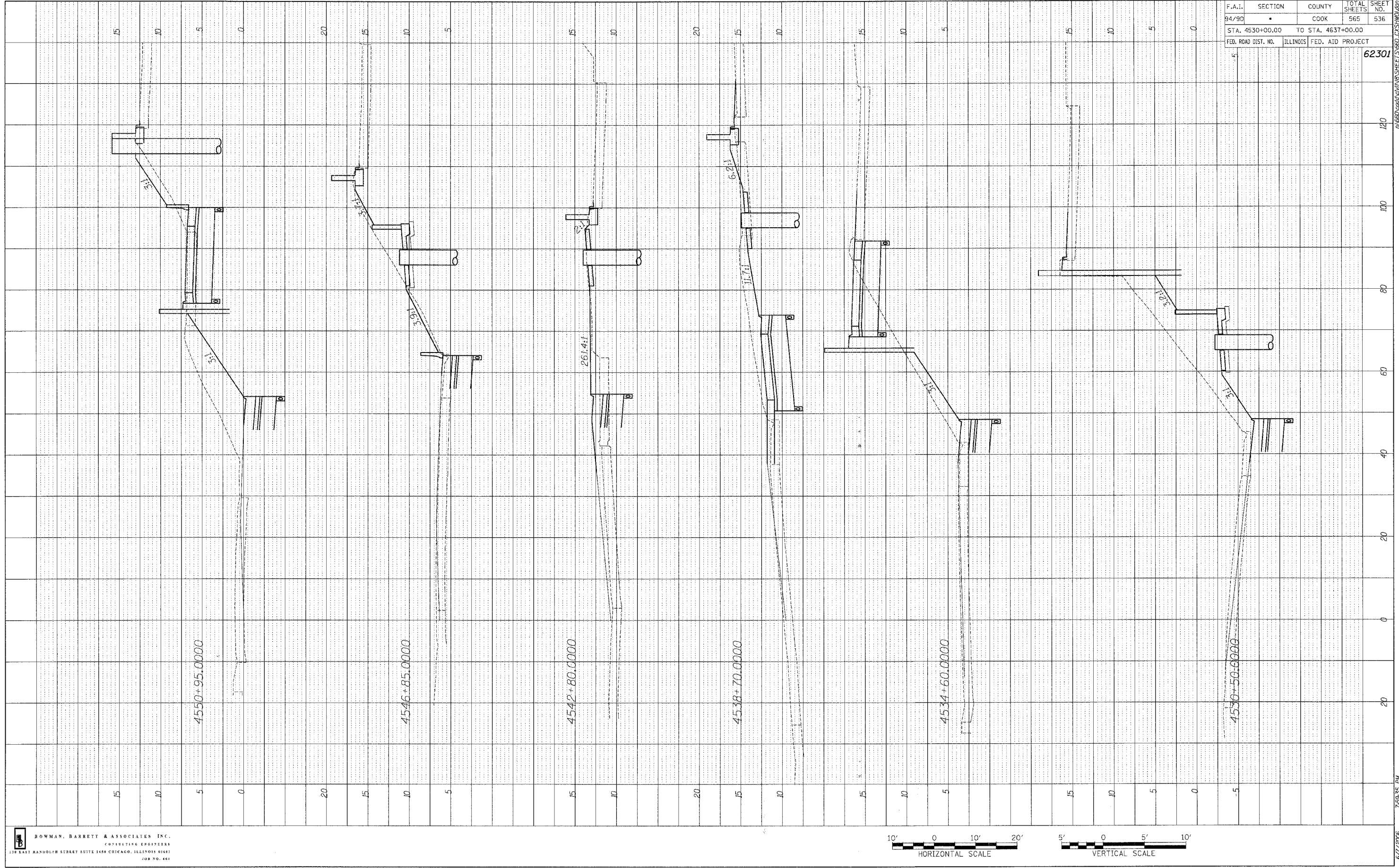

• (2021-922 PT2 ETC 2324.6-IPR-10				
F.A.I.	SECTION	COUNTY	TOTAL SHEETS	SHEET NO.
94/90		COOK	965	537
STA. 4530+00.00		TO STA. 4637+00.00		
FED. ROAD DIST. NO.	ILLINOIS	FED. AID PROJECT		

62301

PROFILE	SURVEYED	DATE
NOTE BOOK	PLOTTED	
NO.	BY	
	DATE	
	BY	
	DATE	

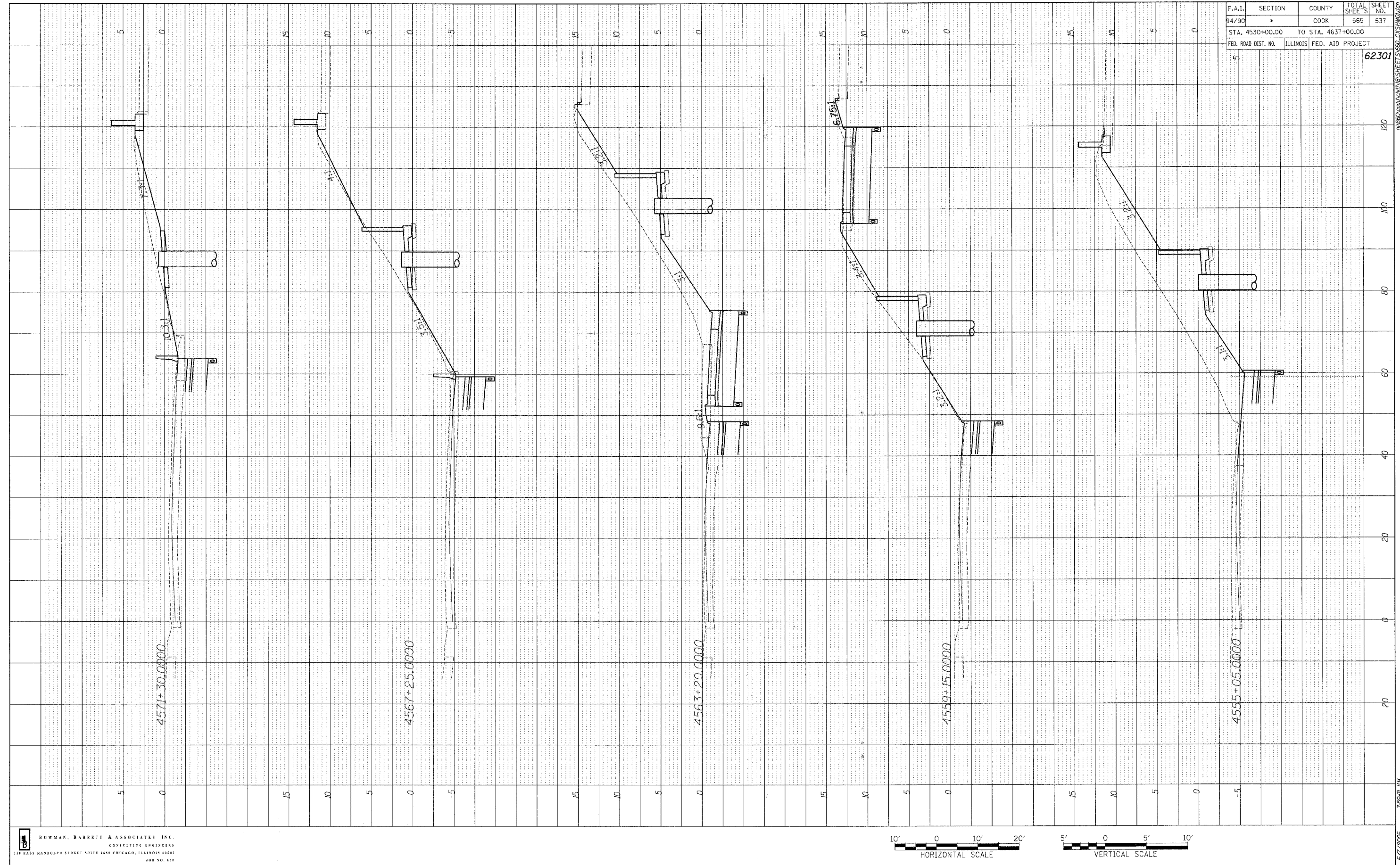

BOWMAN, BARRETT & ASSOCIATES INC.
 CONSULTING ENGINEERS
 131 EAST RANDOLPH STREET SUITE 2450 CHICAGO, ILLINOIS 60601
 312.467.4400

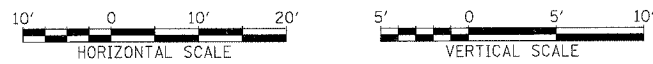

7/28/06 PM

F.A.I.	SECTION	COUNTY	TOTAL SHEETS	SHEET NO.
94/90	*	COOK	565	538
STA. 4530+00.00		TO STA. 4637+00.00		
FED. ROAD DIST. NO.	ILLINOIS	FED. AID PROJECT		

62301

PROFILE	DATE
SURVEYED	
PLOTTED	
CHECKED	
NOTE BOOK	
NO.	
STRUCTURE NOTATIONS	CHVD

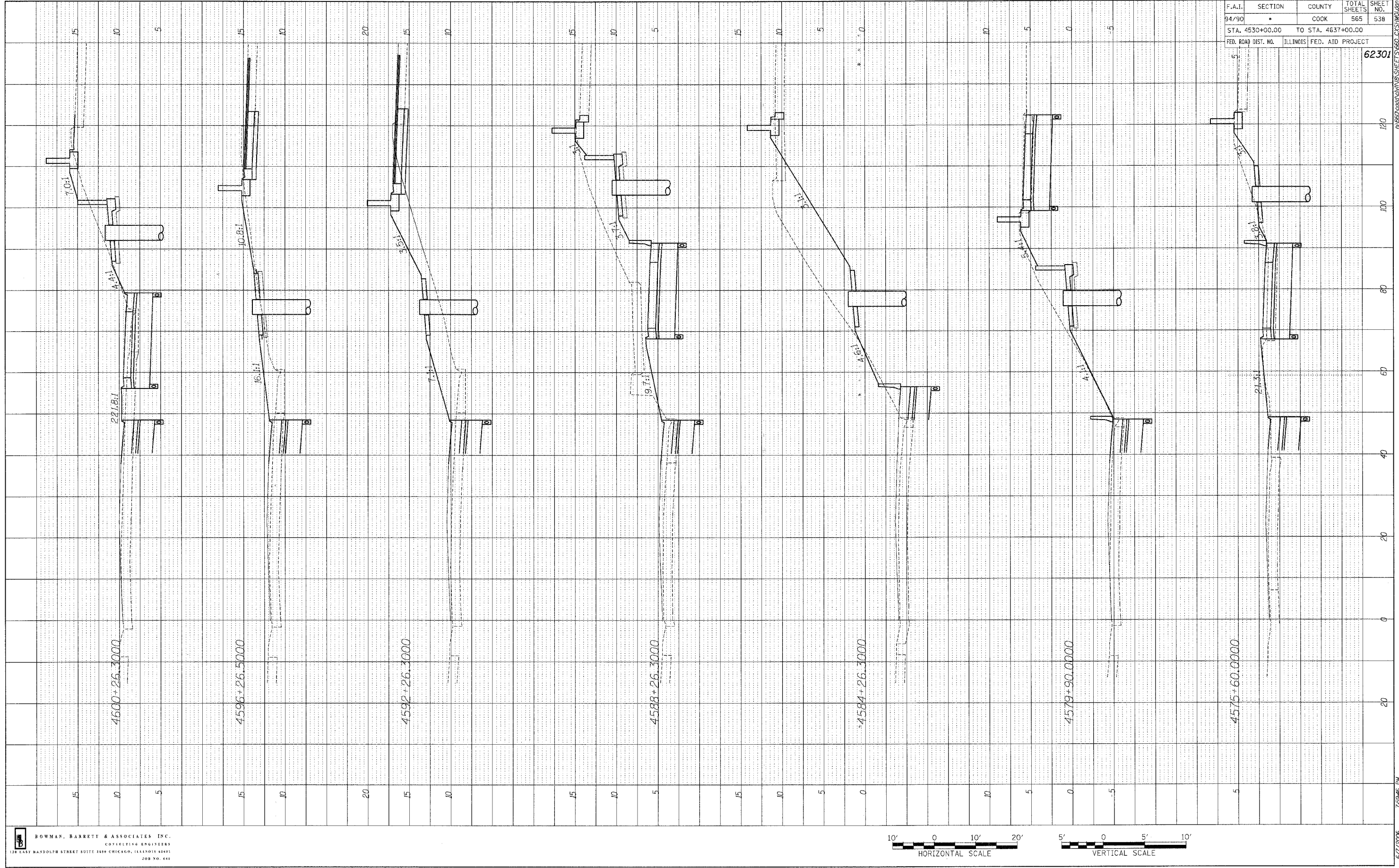

BOWMAN, BARRETT & ASSOCIATES INC.
 CONSULTING ENGINEERS
 138 EAST RANDOLPH STREET SUITE 3550 CHICAGO, ILLINOIS 60601
 708 NO. 440

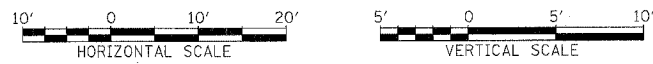

F.A.I.	SECTION	COUNTY	TOTAL SHEETS	SHEET NO.
94/90		COOK	565	539
STA. 4530+00.00		TO STA. 4637+00.00		
FED. ROAD DIST. NO.		ILLINOIS FED. AID PROJECT		

62301

PROFILE	SURVEYED	DATE
NO. _____	BY _____	_____
NOTE BOOK _____	DATE _____	_____
STRUCTURE NOTATION CHFD _____	DATE _____	_____

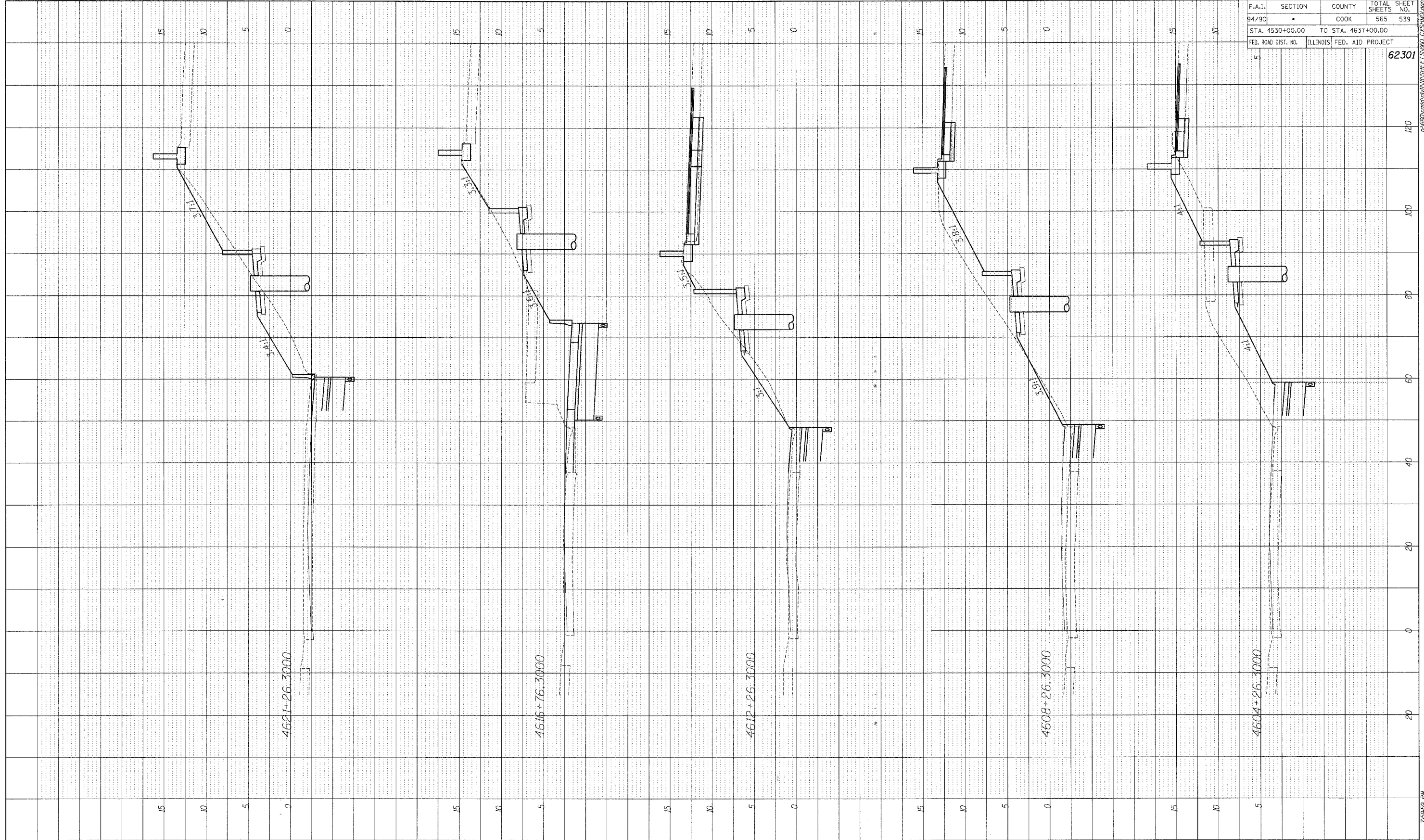

BOWMAN, BARRETT & ASSOCIATES INC.
 CONSULTING ENGINEERS
 138 EAST MADISON STREET SUITE 2400 CHICAGO, ILLINOIS 60601
 TEL: 312.467.4400

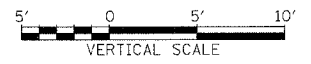

F.A.I.	SECTION	COUNTY	TOTAL SHEETS	SHEET NO.
94/90		COOK	565	540
STA. 4530+00.00		TO STA. 4637+00.00		
FED. ROAD DIST. NO.		ILLINOIS FED. AID PROJECT		

62301

PROFILE	SURVEYED	BY	DATE
NOTE BOOK	GRADES CHECKED		
NO.	BY		
	DATE		

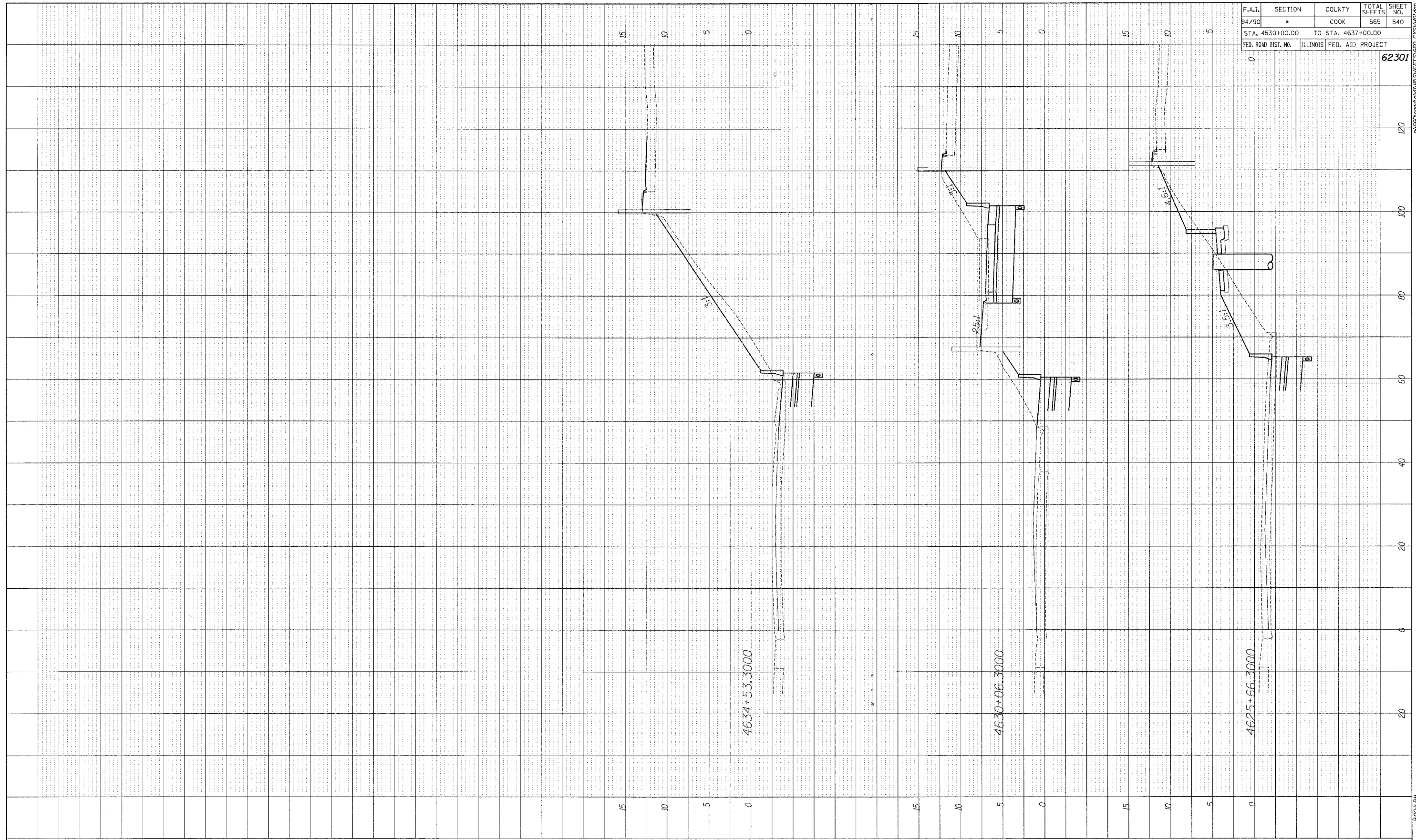

BOWMAN, BARRETT & ASSOCIATES INC.
 CONSULTING ENGINEERS
 225 EAST RANDOLPH STREET SUITE 2050 CHICAGO, ILLINOIS 60601
 JOB NO. 650

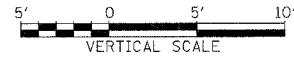

6/7/2006 9:00 AM

F.A.I. RTE.	SECTION	COUNTY	TOTAL SHEETS	SHEET NO.
90/94	*	COOK	565	541
FED. ROAD DIST. NO. 1 ILLINOIS FED. AID PROJECT				
62301 • (2021-922 PT2 ETC 2324.6-1P) R-10				

FINAL SURVEY	DATE
REVISIONS	
NO.	

ORIGINAL SURVEY	DATE
REVISIONS	
NO.	

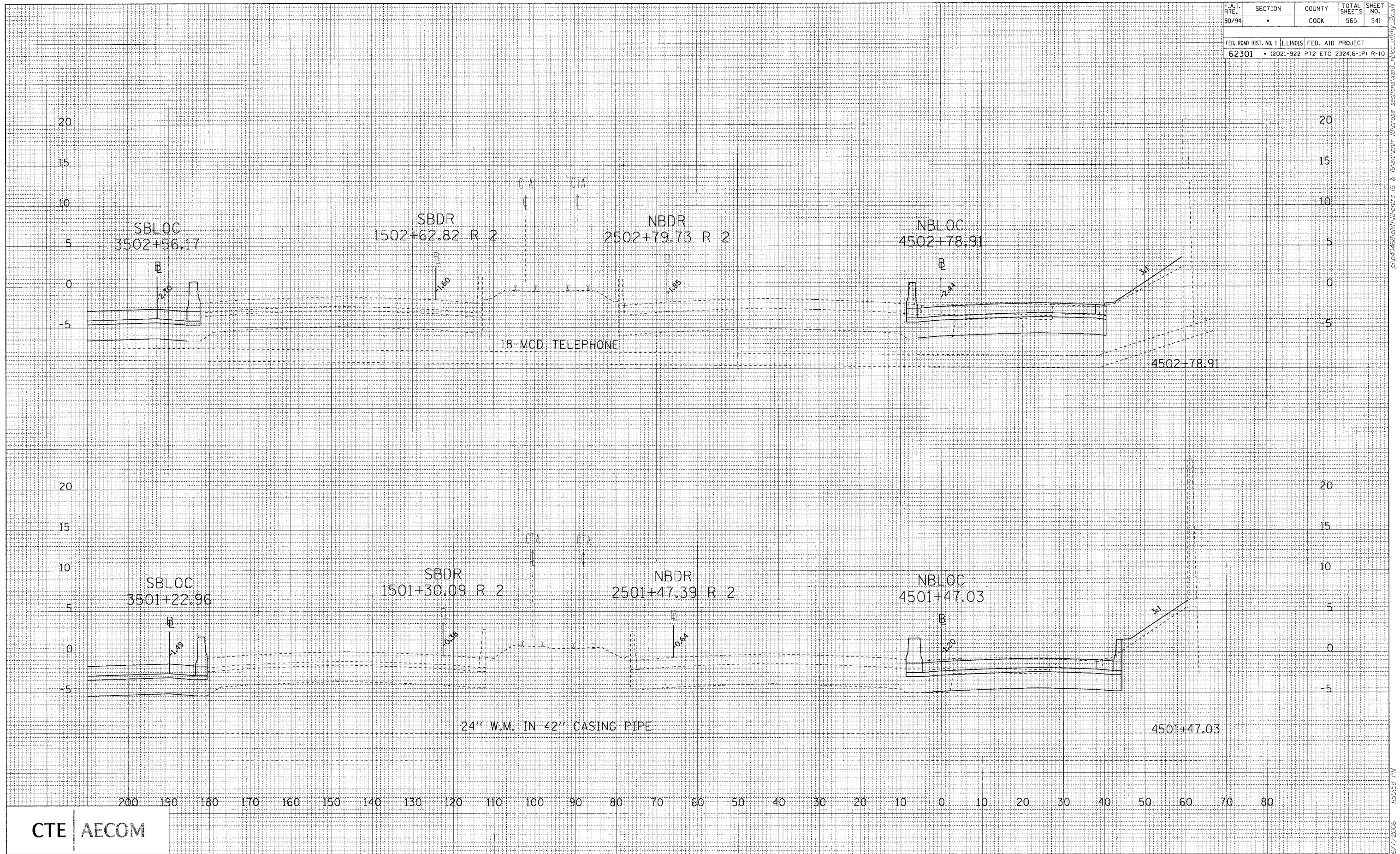

CTE | AECOM

P:\p\466\ch\NB-cmts 18 & 19\cvt\117\18cross sections\vis\B_nblloc_utility_2017.rvt

F.A.I. RTE.	SECTION	COUNTY	TOTAL SHEETS	SHEET NO.
90/94	*	COOK	565	542
FED. ROAD DIST. NO. 1 ILLINOIS FED. AID PROJECT				
62301 * (2021-922 PT2 ETC 2324.6-1P) R-10				

DATE	BY
DATE	BY
DATE	BY

DATE	BY
DATE	BY
DATE	BY

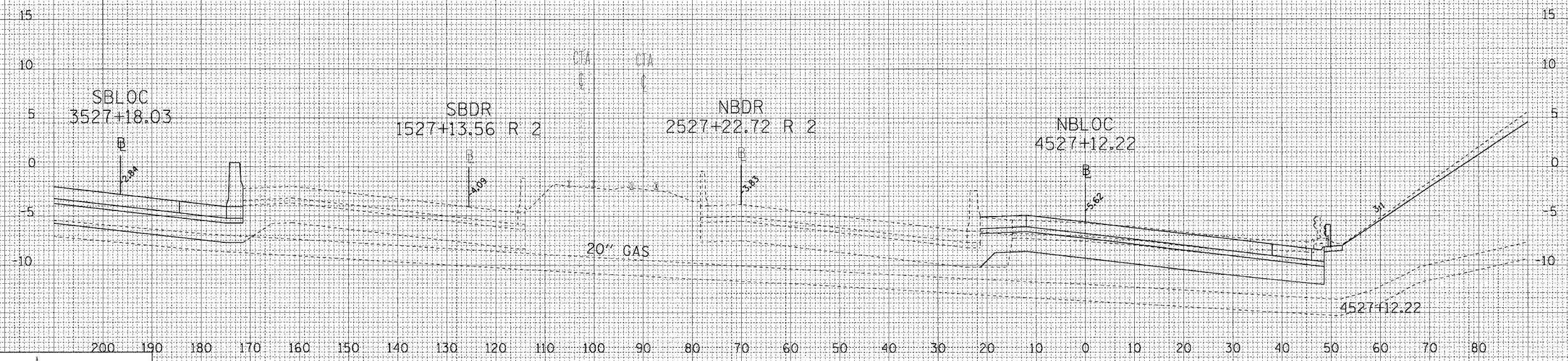

CTE | AECOM

6/7/2006 15:00 PM

F.A.T. RTE.	SECTION	COUNTY	TOTAL SHEETS	SHEET NO.
94/90	*	COOK	565	543
FED. ROAD DIST. NO. 1 ILLINOIS FED. AID PROJECT				
• (2021-922 PT2 ETC 2324.6-1P1R-10				

DATE	BY
SURVEYED	PLOTTED
NOTE BOOK	NO.
AREAS CHECKED	

DATE	BY
SURVEYED	PLOTTED
NOTE BOOK	NO.
AREAS CHECKED	

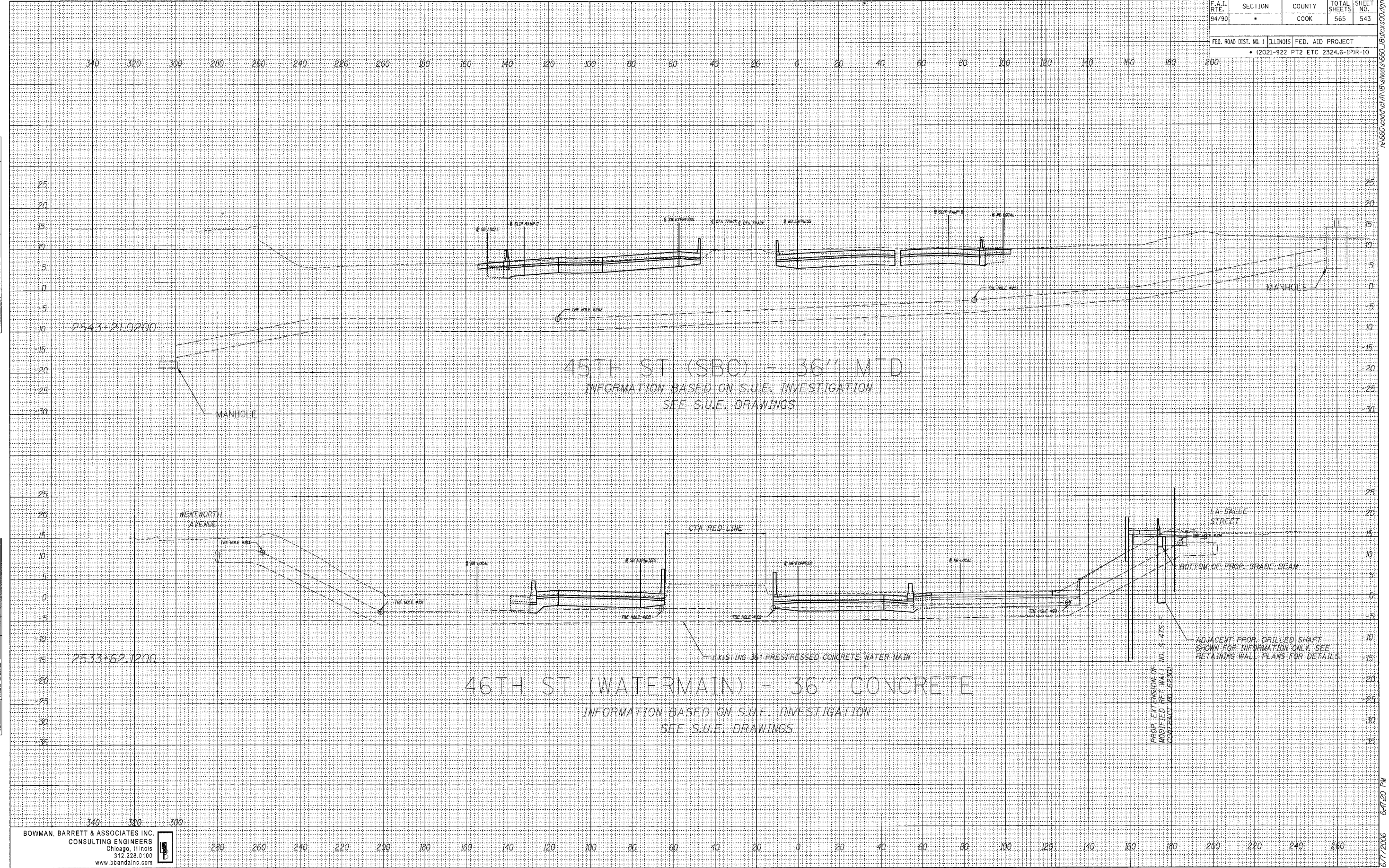

6-7-2006 6:47:20 PM

F.A.T. RTE.	SECTION	COUNTY	TOTAL SHEETS	SHEET NO.
94/90	*	COOK	565	544
FED. ROAD DIST. NO. 1		ILLINOIS	FED. AID PROJECT	
			• (2021-922 PT2 ETC 2324.6-1PR-10	

DATE	
BY	
FINAL SURVEY	
NOTE BOOK	
NO.	
SURVEYED	
TEMPLATE	
AREAS	
CHECKED	

DATE	
BY	
ORIGINAL SURVEY	
NOTE BOOK	
NO.	
SURVEYED	
TEMPLATE	
AREAS	
CHECKED	

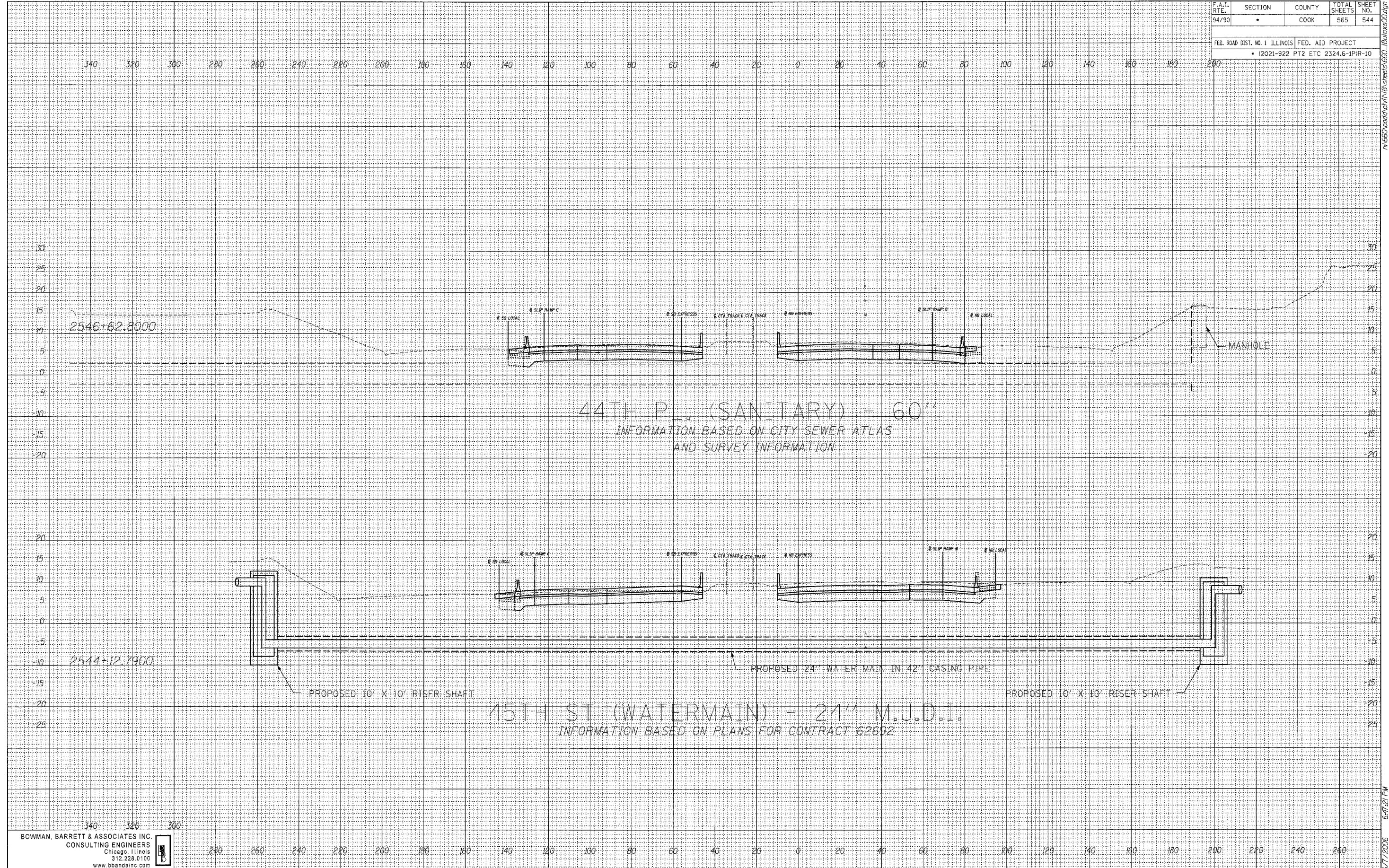

na560\cad\civil\IB\Sheets\660_18\18x560.dgn

6/7/2006 6:47:21 PM

62301

F.A.I. RTE.	SECTION	COUNTY	TOTAL SHEETS	SHEET NO.
94/90		COOK	565	545
FED. ROAD DIST. NO. 1 ILLINOIS FED. AID PROJECT				
• (2021-922 PT2 ETC 2324.6-IPR-10				

DATE	
BY	
FINAL SURVEY	
SURVEYED	
PLOTTED	
NOTE BOOK	
AREAS CHECKED	
NO.	

DATE	
BY	
ORIGINAL SURVEY	
SURVEYED	
PLOTTED	
NOTE BOOK	
AREAS CHECKED	
NO.	

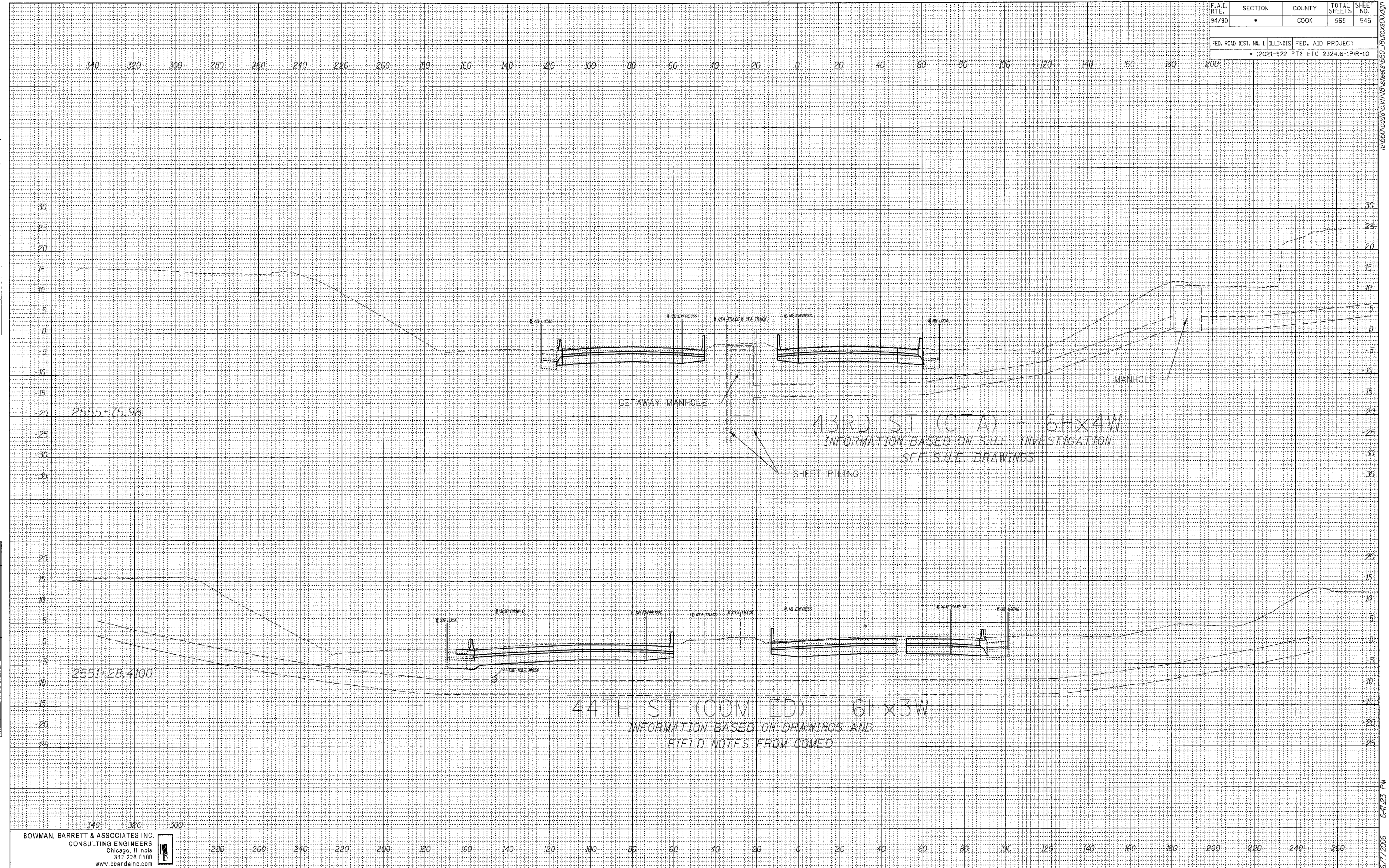

BOWMAN, BARRETT & ASSOCIATES INC.
CONSULTING ENGINEERS
Chicago, Illinois
312.228.0100
www.bbainc.com



n:\660\cadd\cvt\18\streets\660_18\cass00.dgn

6-7-23 PM
6/7/2005

F.A.I. RTE.	SECTION	COUNTY	TOTAL SHEETS	SHEET NO.
94/90	•	COOK	565	546
FED. ROAD DIST. NO. 1 ILLINOIS FED. AID PROJECT				
• (2021-922 PT2 ETC 2324.6-IPR-10				

BY		DATE
FINAL SURVEY	SURVEYED	
NOTE BOOK	PLOTTED	
NO.	AREAS CHECKED	

BY		DATE
ORIGINAL SURVEY	SURVEYED	
NOTE BOOK	PLOTTED	
NO.	AREAS CHECKED	

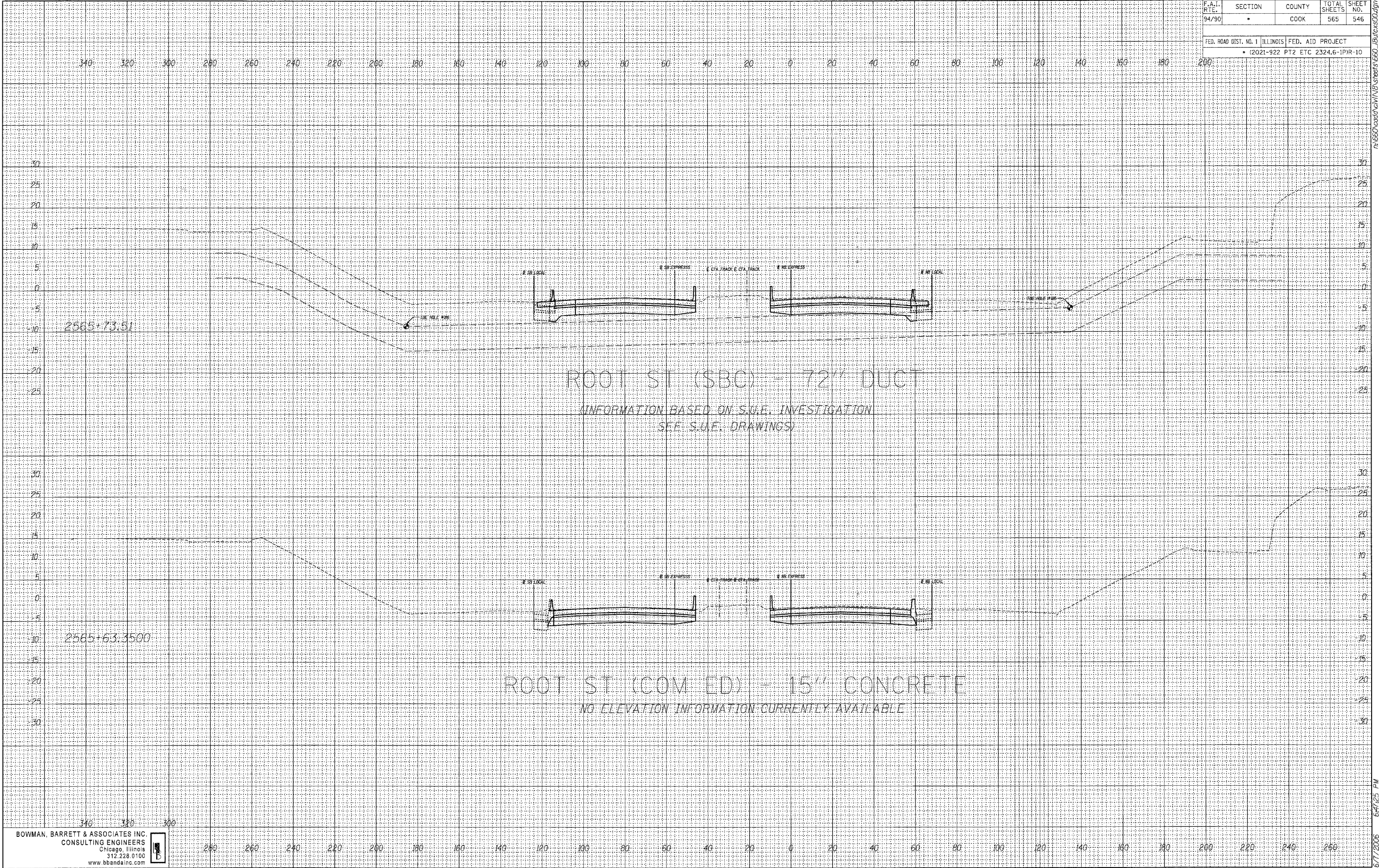

T:\660\cadd\civil\IB sheets\660_IB\62301.dgn

6/7/2006 6:47:25 PM

62301

F.A.T. RTE.	SECTION	COUNTY	TOTAL SHEETS	SHEET NO.
94/90	*	COOK	565	547
FED. ROAD DIST. NO. 1 ILLINOIS FED. AID PROJECT				
* (2021-922 PT2 ETC 2324.6-1PR-10				

DATE	
BY	
FINAL SURVEY	
PLOTTED	
NOTE BOOK	
AREAS CHECKED	
NO.	

DATE	
BY	
ORIGINAL SURVEY	
PLOTTED	
NOTE BOOK	
AREAS CHECKED	
NO.	

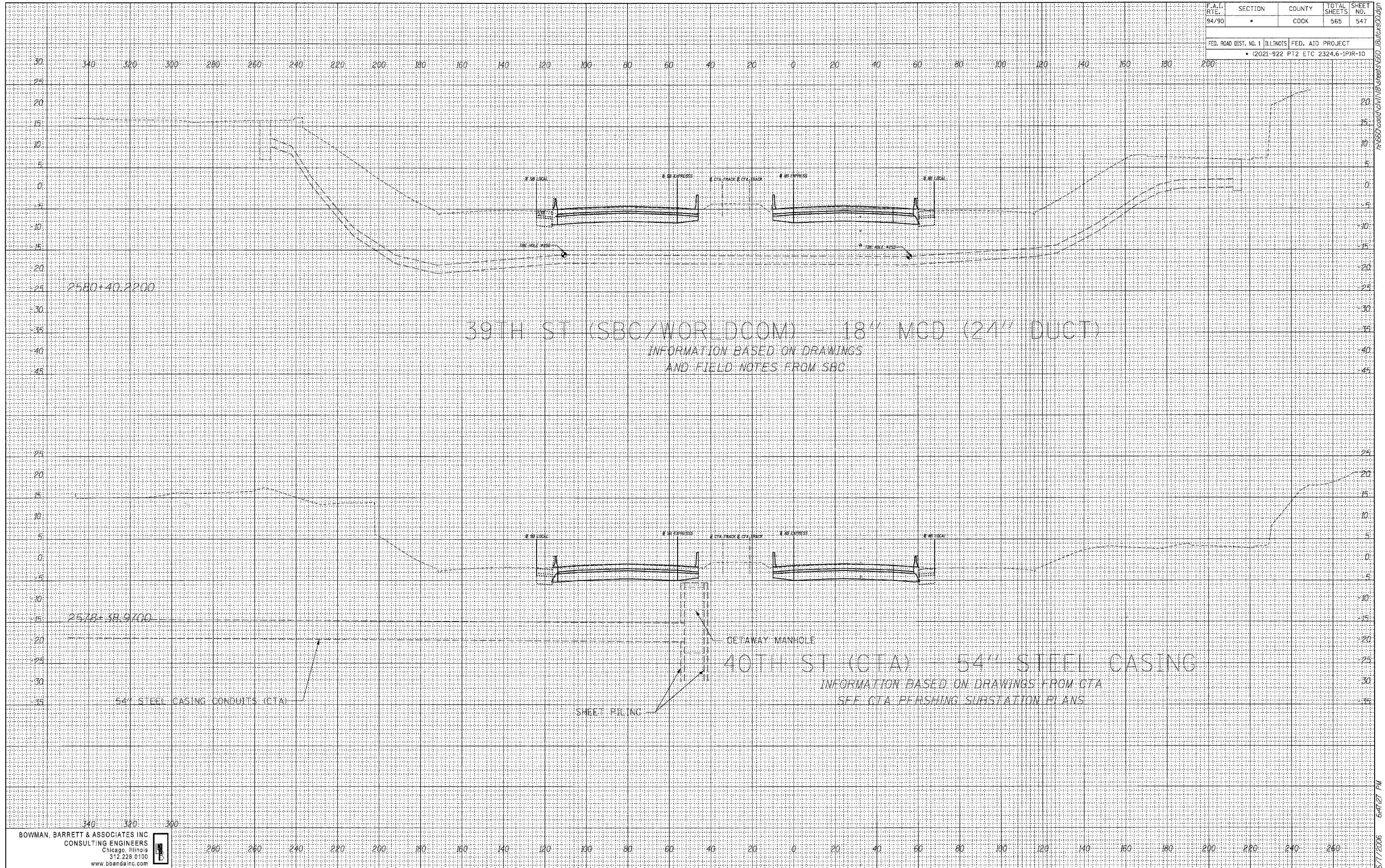

BOWMAN, BARRETT & ASSOCIATES INC
 CONSULTING ENGINEERS
 Chicago, Illinois
 312.228.0100
 www.bbainc.com



7:660:0000\c\m\18\streets\660_18\lts\500.dgn

6/7/2006 6:47:27 PM

F.A.T. RTE.	SECTION	COUNTY	TOTAL SHEETS	SHEET NO.
94/90		COOK	565	546
FED. ROAD DIST. NO. 1		ILLINOIS	FED. AID PROJECT	
			• (2021-922 PT2 ETC 2324.6-1PR-10)	

FINAL SURVEY	DATE
BY	
NO. _____	
NOTE BOOK	
NO. _____	
TEMPLATE	
AREAS CHECKED	

ORIGINAL SURVEY	DATE
BY	
NO. _____	
NOTE BOOK	
NO. _____	
TEMPLATE	
AREAS CHECKED	

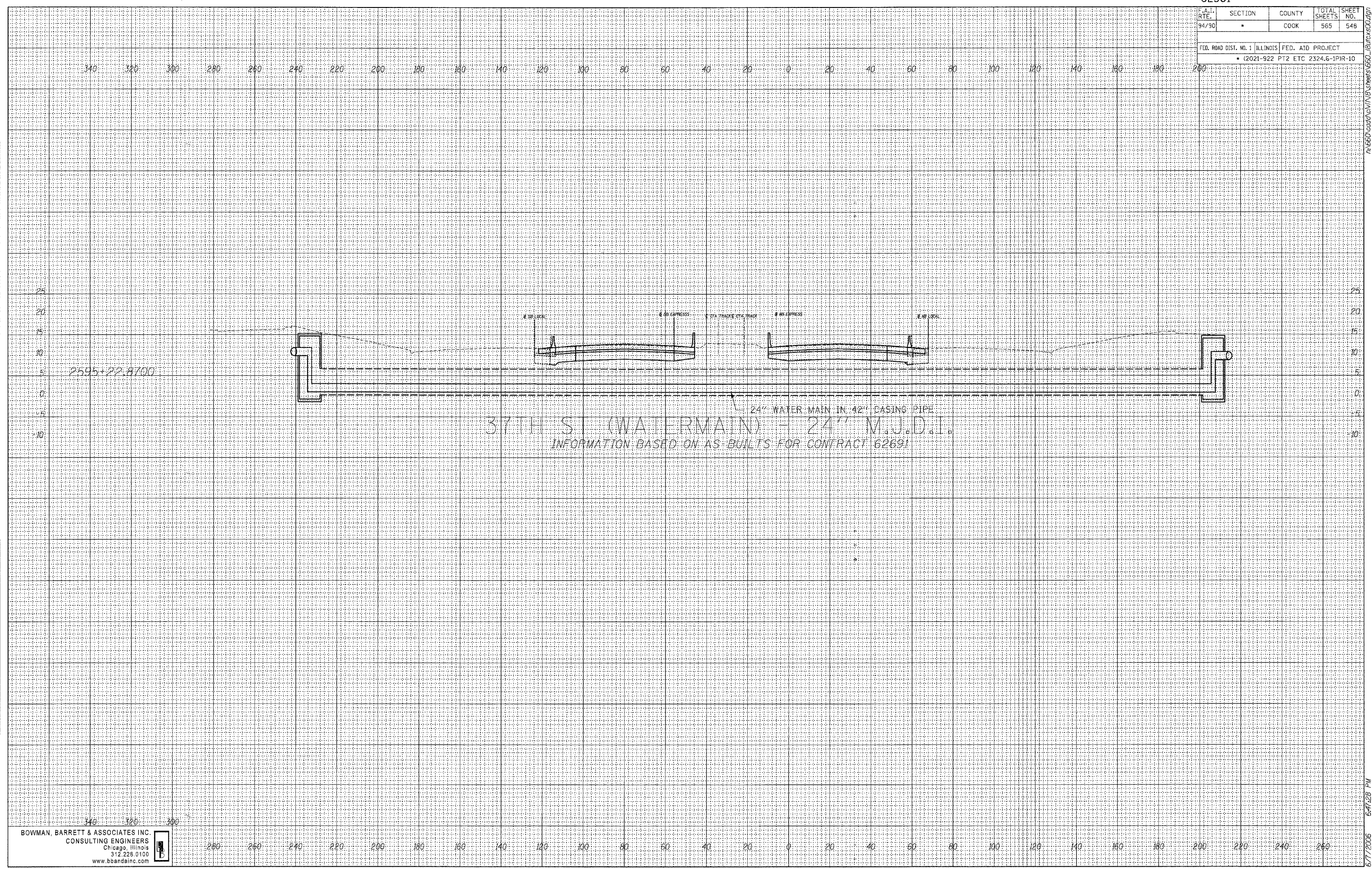

6/7/2006 5:47:28 PM

F.A.I. RTE.	SECTION	COUNTY	TOTAL SHEETS	SHEET NO.
94/90	*	COOK	565	549

FED. ROAD DIST. NO. 1	ILLINOIS	FED. AID PROJECT
(2021-922 PT2 ETC	2324.6-1PR-10	

DATE	
BY	
FINAL SURVEY	
PLOTTED	
NOTE BOOK	
AREAS CHECKED	

DATE	
BY	
ORIGINAL SURVEY	
PLOTTED	
NOTE BOOK	
AREAS CHECKED	

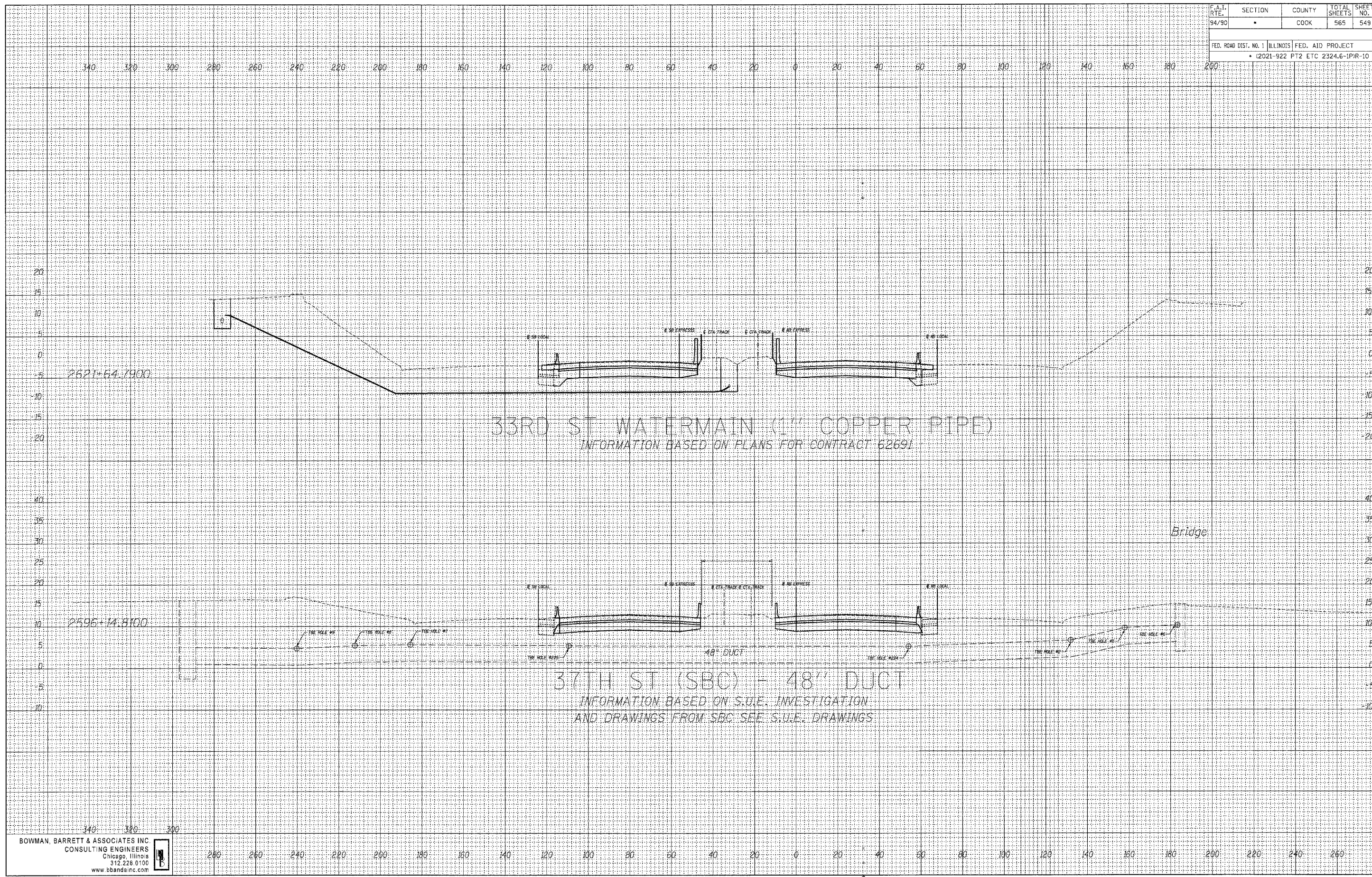

62301

F.A.I. RTE.	SECTION	COUNTY	TOTAL SHEETS	SHEET NO.
94/90	*	COOK	565	550
FED. ROAD DIST. NO. 1 ILLINOIS FED. AID PROJECT				
* (2021-922 PT2 ETC 2324.6-1PR-10				

BY	DATE
SURVEYED	
TEMPLATE	
AREAS	
CHECKED	
NO.	

BY	DATE
SURVEYED	
TEMPLATE	
AREAS	
CHECKED	
NO.	

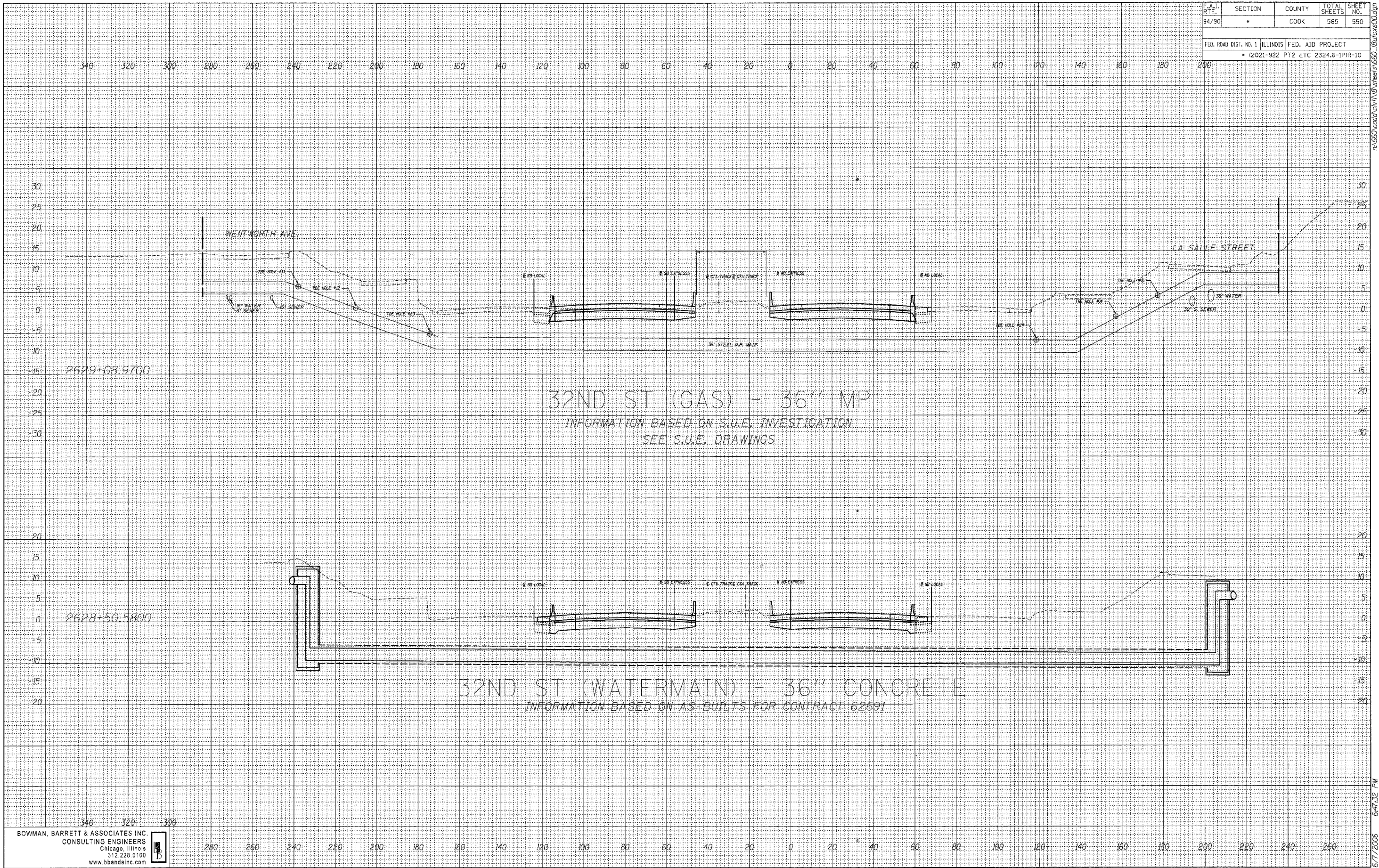

2629+08.5700

2628+50.5800

BOWMAN, BARRETT & ASSOCIATES INC.
 CONSULTING ENGINEERS
 Chicago, Illinois
 312.228.0100
 www.bbainc.com

6/7/2006 6:47:32 PM

62301

F.A.I. RTE.	SECTION	COUNTY	TOTAL SHEETS	SHEET NO.
94/90	*	COOK	565	551
FED. ROAD DIST. NO. 1		ILLINOIS		FED. AID PROJECT
		* (2021-922 PT2 ETC 2324.6-1P)R-11		

BY	DATE
SURVEYED	
PLOTTED	
NOTE BOOK	
AREAS	
CHECKED	

BY	DATE
SURVEYED	
PLOTTED	
NOTE BOOK	
AREAS	
CHECKED	

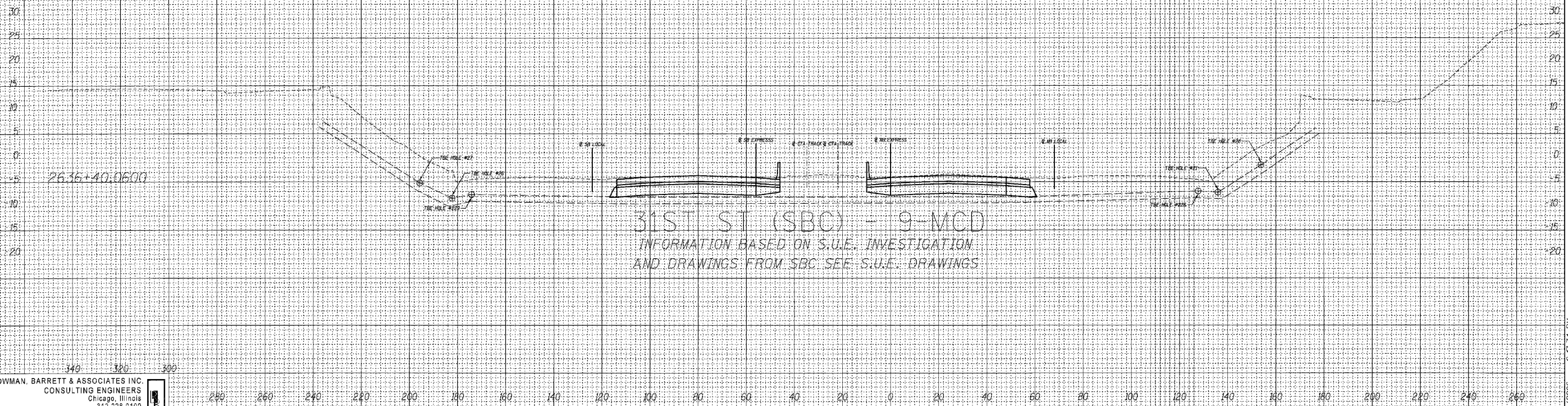

BOWMAN, BARRETT & ASSOCIATES INC.
CONSULTING ENGINEERS
Chicago, Illinois
312.238.0100
www.bbainc.com



6-7-2006 6:47:34 PM

F.A.J. RTE.	SECTION	COUNTY	TOTAL SHEETS	SHEET NO.
94		COOK	565	553
STA. TO STA.		ILLINOIS FED. AID PROJECT		
FED. ROAD DIST. NO.		* - PENDING I.D.O.T. PROGRAMMING		



PLAN	DATE
NO.	
NOTE BOOK	
REVISIONS	
BY	
DATE	

PROFILE	DATE
NO.	
NOTE BOOK	
REVISIONS	
BY	
DATE	

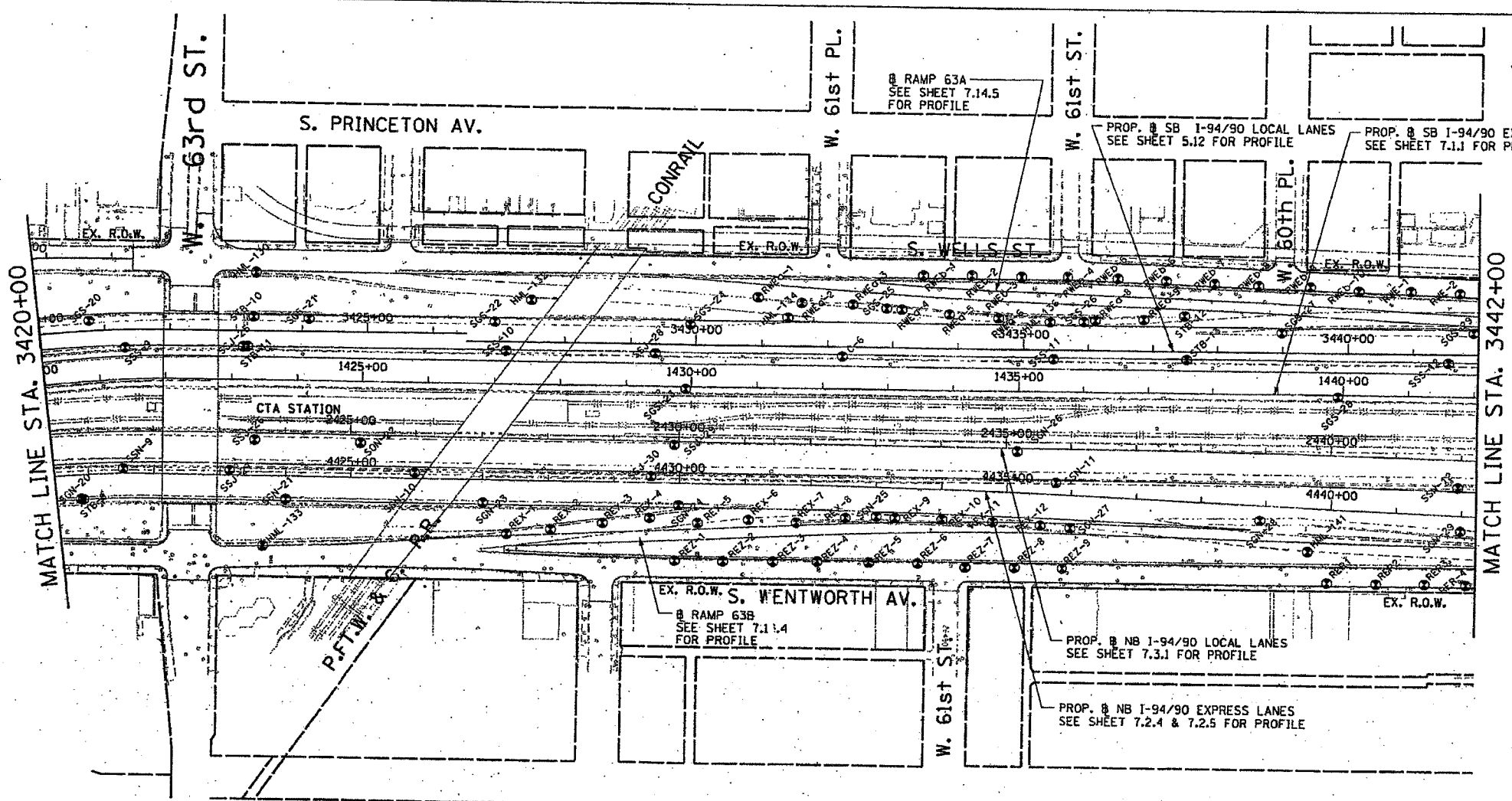

- LEGEND FOR BORINGS**
- ⊙ HML : HIGH MAST LIGHT POLE
 - ⊖ RED : RETAINING WALL, EAST SIDE, WALL-D
 - ⊖ RED : RETAINING WALL, EAST SIDE, WALL-W
 - ⊖ RWC : RETAINING WALL, WEST SIDE, WALL-C
 - ⊖ RWL : RETAINING WALL, WEST SIDE, WALL-L
 - ⊖ SIA : RETAINING WALL, INTERCHANGE, WALL IA
 - ⊖ SSN : STORM SEWER, NORTHBOUND
 - ⊖ SSS : STORM SEWER, SOUTHBOUND
 - ⊖ SSJ : STORM SEWER, JACKING
 - ⊖ STB : SIGN STRUCTURE
 - ⊖ SSB : BRIDGE
 - ⊖ SEW.SWW : BRIDGE
 - ⊖ SGN : SUBGRADE, NORTHBOUND
 - ⊖ SGS : SUBGRADE, SOUTHBOUND
 - ⊖ BRN : 47th ST. RAMP
 - C : CORING

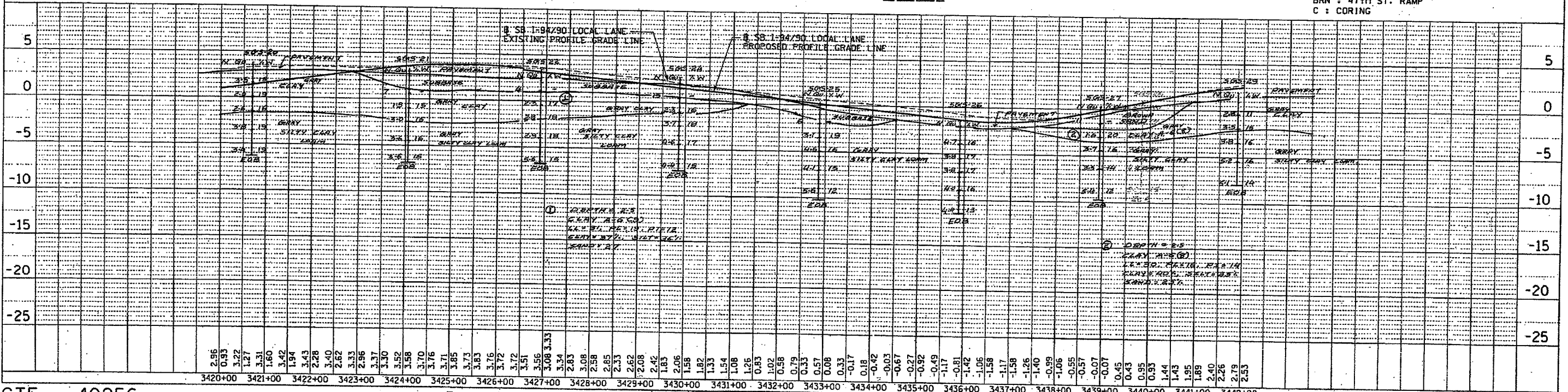

F.A.J. RITE.	SECTION	COUNTY	TOTAL SHEETS	SHEET NO.
94	*	COOK	565	554
STA.	TO STA.			
FED. ROAD DIST. NO.	ILLINOIS	FED. AID PROJECT		
* - PENDING I.D.O.T. PROGRAMMING				

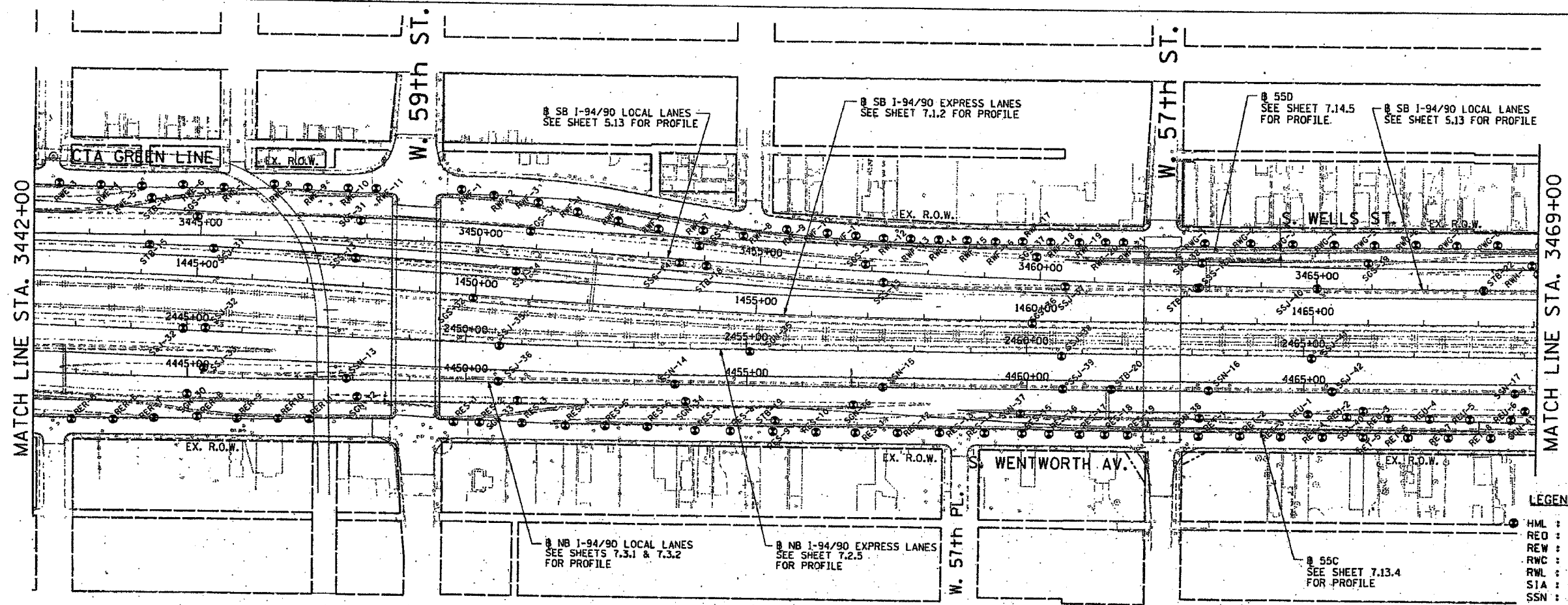

- LEGEND FOR BORINGS**
- HML : HIGH MAST LIGHT POLE
 - RED : RETAINING WALL, EAST SIDE, WALL-D
 - REW : RETAINING WALL, EAST SIDE, WALL-W
 - RWC : RETAINING WALL, WEST SIDE, WALL-C
 - RWL : RETAINING WALL, WEST SIDE, WALL-L
 - SIA : RETAINING WALL, INTERCHANGE, WALL IA
 - SSN : STORM SEWER, NORTHBOUND
 - SSS : STORM SEWER, SOUTHBOUND
 - SSJ : STORM SEWER, JACKING
 - STB : SIGN STRUCTURE
 - SSB : BRIDGE
 - SEW,SWW : BRIDGE
 - SGN : SUBGRADE, NORTHBOUND
 - SGS : SUBGRADE, SOUTHBOUND
 - BRN : 47th ST. RAMP
 - C : CORING

PLAN	DATE
BY	
CHECKED	
DATE	

PROFILE	DATE
BY	
CHECKED	
DATE	

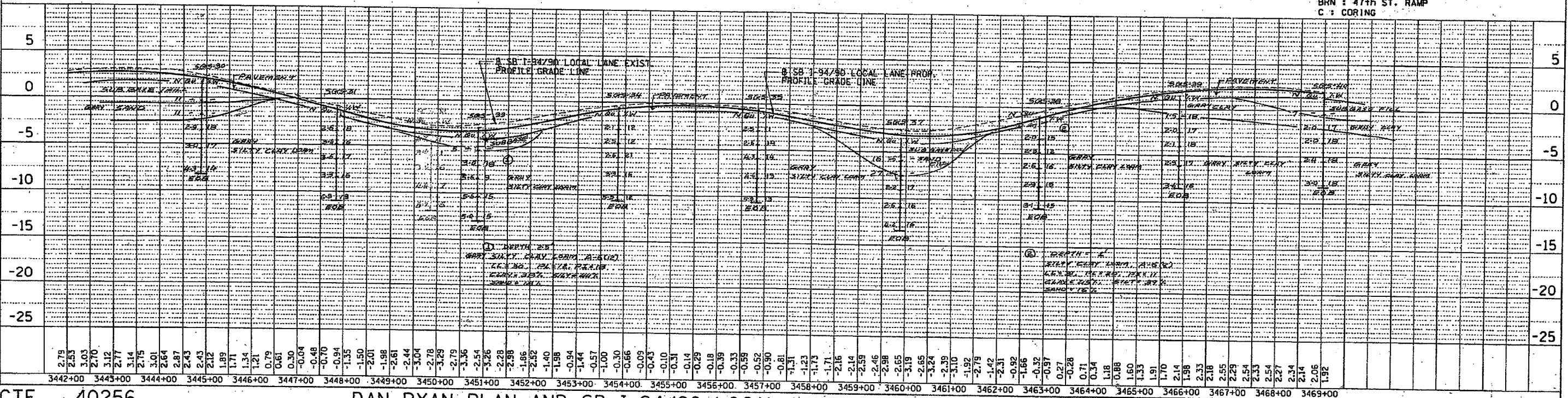

CTE 40256 DAN RYAN PLAN AND SB I-94/90 LOCAL LANES PROFILE SCALE: HORIZ. 1"=100' VERT. 1"=5' EXHIBIT NO. 5.13

R:\1940469\civ\1\02-co-art\soil\profile\468ex05.13.sht
 11/2/2003

F.A.J. RTE.	SECTION	COUNTY	TOTAL SHEETS	SHEET NO.
94	*	COOK	565	556
STA.	TO STA.			
FED. ROAD DIST. NO. ILLINOIS FED. AID PROJECT				
* - PENDING I.D.O.T. PROGRAMMING				

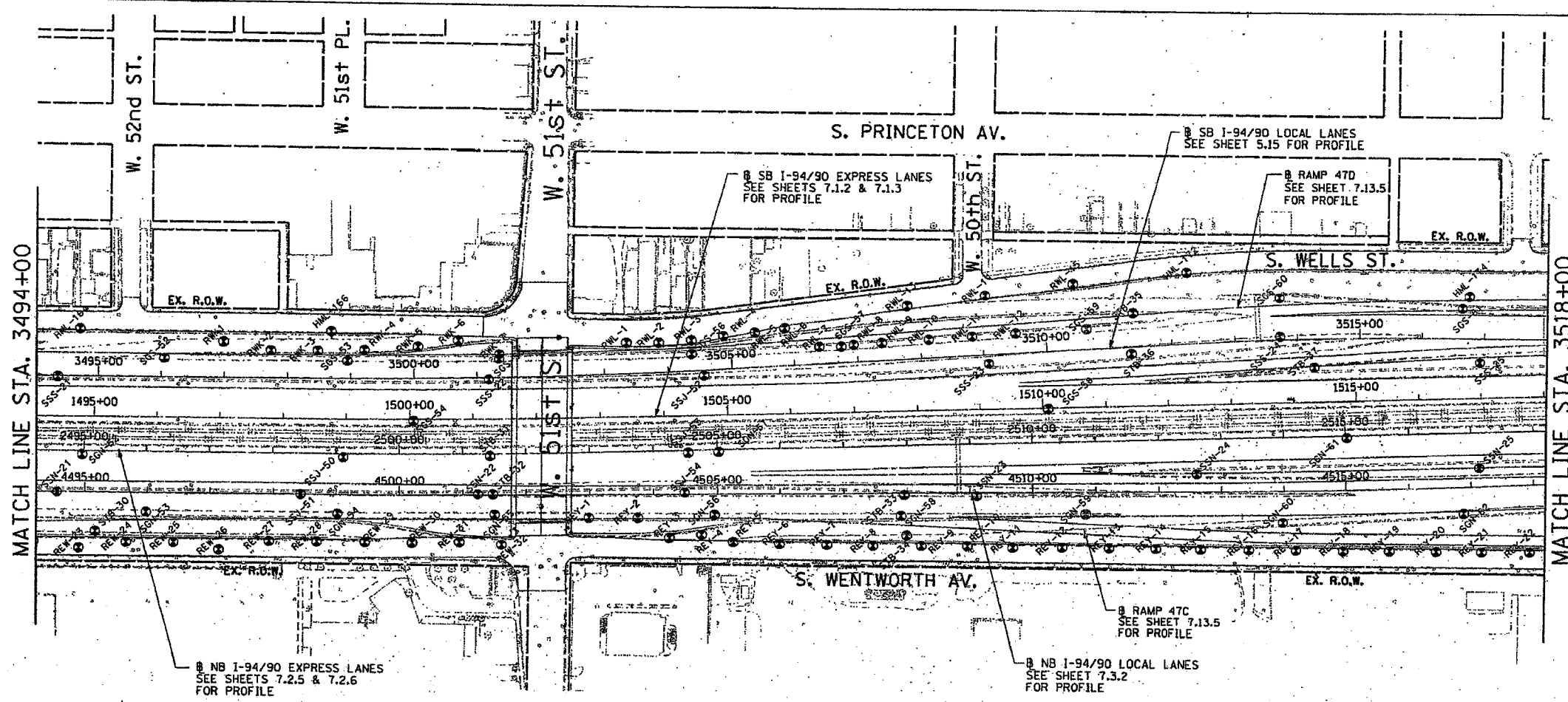

- LEGEND FOR BORINGS**
- ⊙ HML : HIGH MAST LIGHT POLE
 - REO : RETAINING WALL, EAST SIDE, WALL-D
 - REW : RETAINING WALL, EAST SIDE, WALL-W
 - RWC : RETAINING WALL, WEST SIDE, WALL-C
 - RWL : RETAINING WALL, WEST SIDE, WALL-L
 - SIA : RETAINING WALL, INTERCHANGE, WALL IA
 - SSN : STORM SEWER, NORTHBOUND
 - SSS : STORM SEWER, SOUTHBOUND
 - SSJ : STORM SEWER, JACKING
 - STB : SIGN STRUCTURE
 - SSB : BRIDGE
 - SEW.SWW : BRIDGE
 - SGN : SUBGRADE, NORTHBOUND
 - SGS : SUBGRADE, SOUTHBOUND
 - BRN : 47th ST. RAMP
 - C : CORING

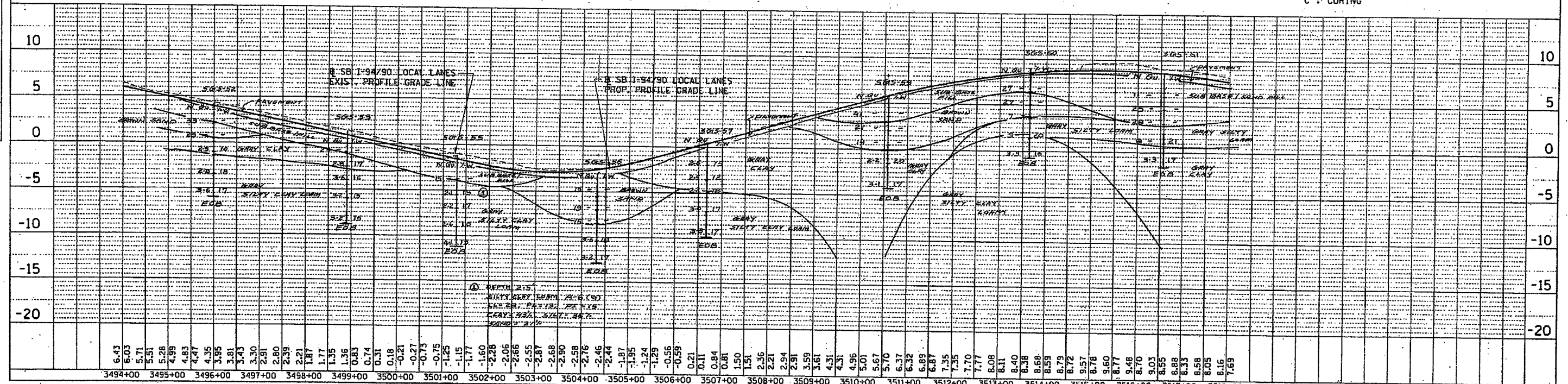

DATE	BY	CHKD

DATE	BY	CHKD

M:\p\0468\civil\02-dc\sh\soil\profile\468ex05.15.shp
 1/27/2005

F.A.J. RTE. 94	SECTION #	COUNTY COOK	TOTAL SHEETS NO. 565	SHEET NO. 557
STA. TO STA.		FED. ROAD DIST. NO. ILLINOIS FED. AID PROJECT		
* - PENDING I.D.O.T. PROGRAMMING				

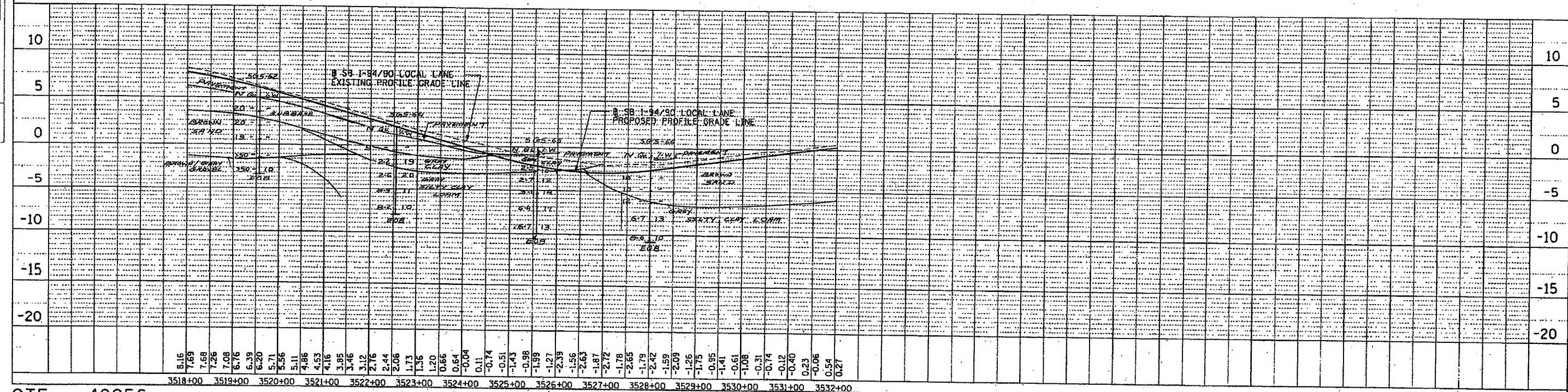
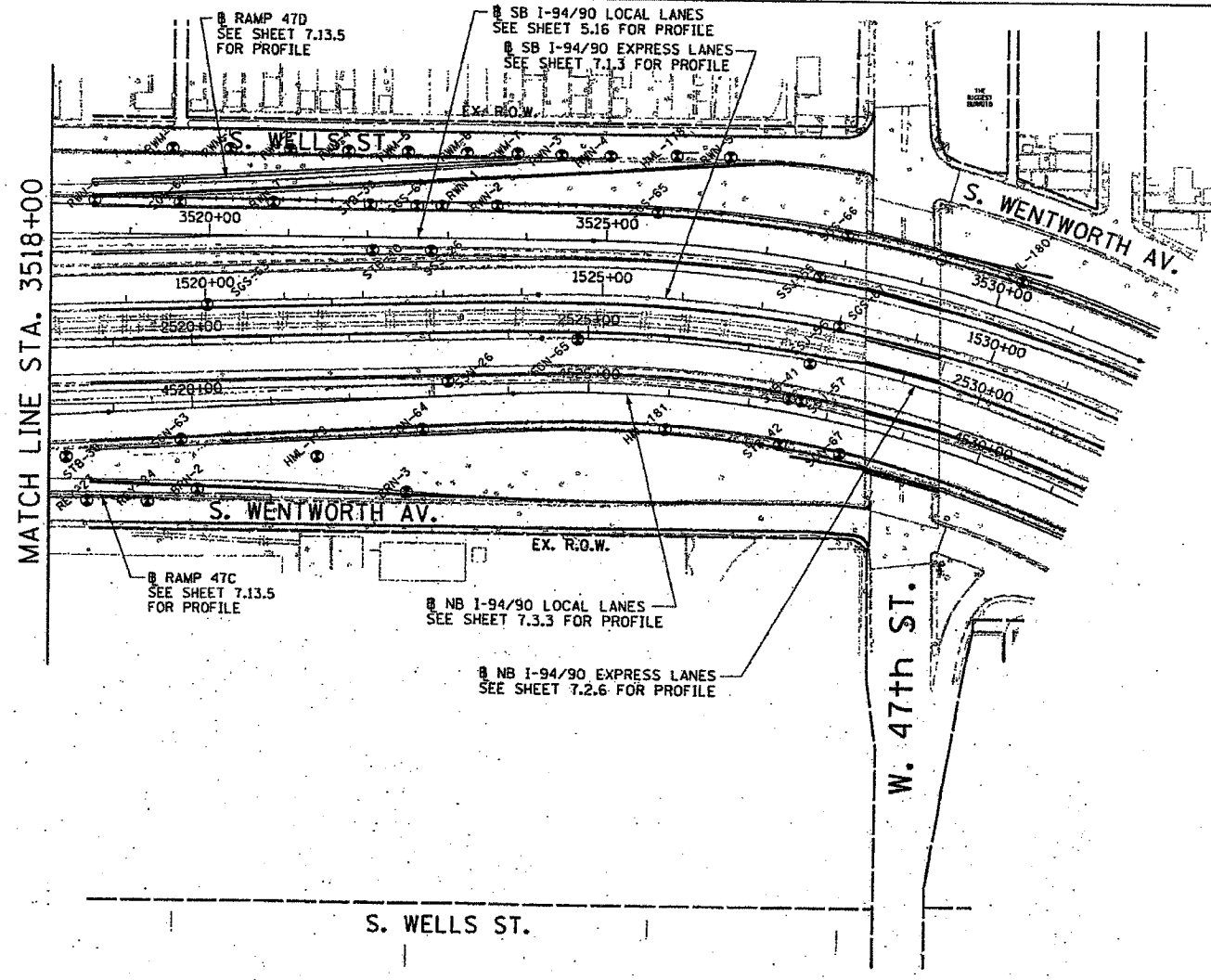

DATE	BY

PLAN

NOTE BOOK NO. 240 FILE NAME

DATE	BY

PROFILE

NOTE BOOK NO. 240 FILE NAME

m:\p\040468\civil\02-dc\sh1\soil profile\468ex05_16.shp 11/27/2003

CTE 40256

DAN RYAN PLAN AND SB I-94/90 LOCAL LANES PROFILE

SCALE: HORIZ. 1"=100' VERT. 1"=5'

EXHIBIT NO. 5.16

F.A. I. RTE.	SECTION	COUNTY	TOTAL SHEETS	SHEET NO.
94	*	COOK	565	558
STA.	TO STA.			
FED. ROAD DIST. NO.	ILLINOIS FED. AID PROJECT			
* - PENDING I.D.O.T. PROGRAMMING				

PLAN	DATE
BY	
REVISION	
NO.	
DATE	
BY	
REVISION	
NO.	
DATE	

PROFILE	DATE
BY	
REVISION	
NO.	
DATE	
BY	
REVISION	
NO.	
DATE	

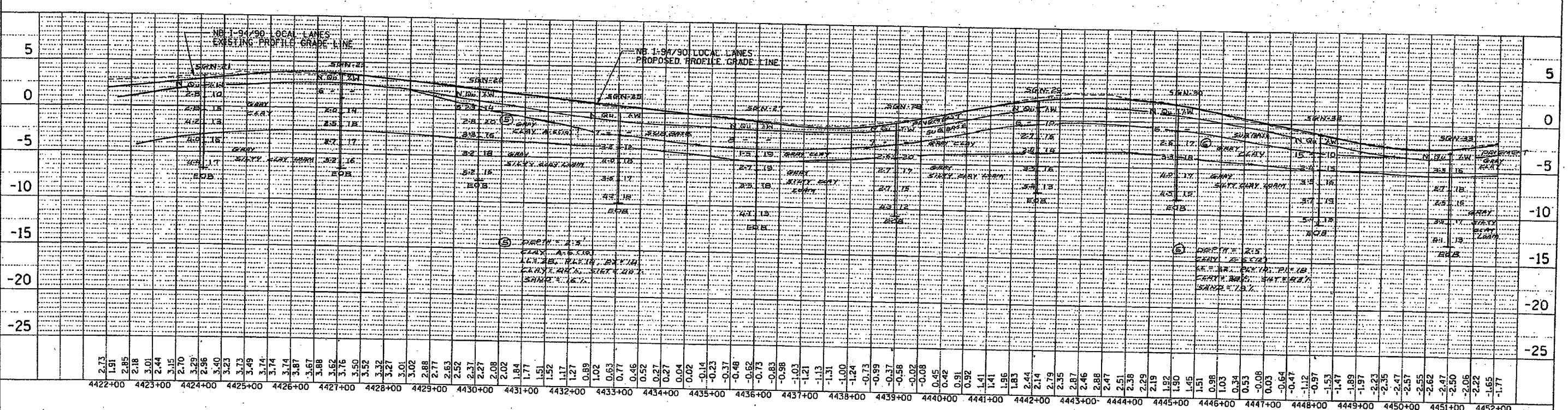
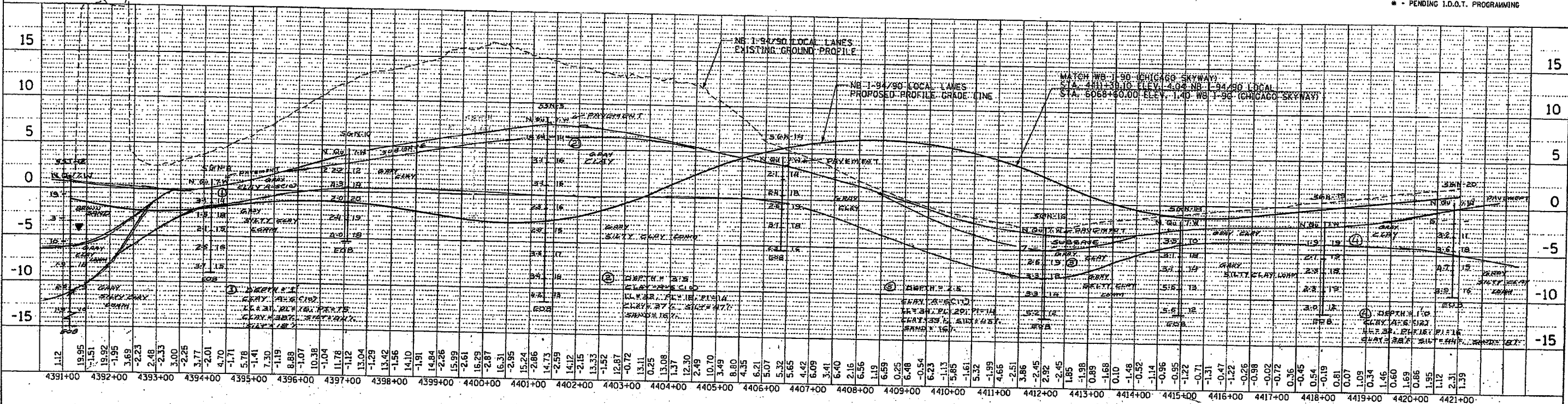

m:\p40468\civil\02-dc\sh\soil\profile\458\exh07_03_01.sht
11/2/2003

F.A.I. SECTION COUNTY TOTAL SHEET SHEET NO.	94 * COOK 565 559
STA. TO STA.	
FED. ROAD DIST. NO. ILLINOIS FED. AID PROJECT	
* - PENDING I.D.O.T. PROGRAMMING	

DATE	
BY	
REVISION	
APPROVED	
DATE	
BY	
REVISION	
APPROVED	
DATE	
BY	
REVISION	
APPROVED	

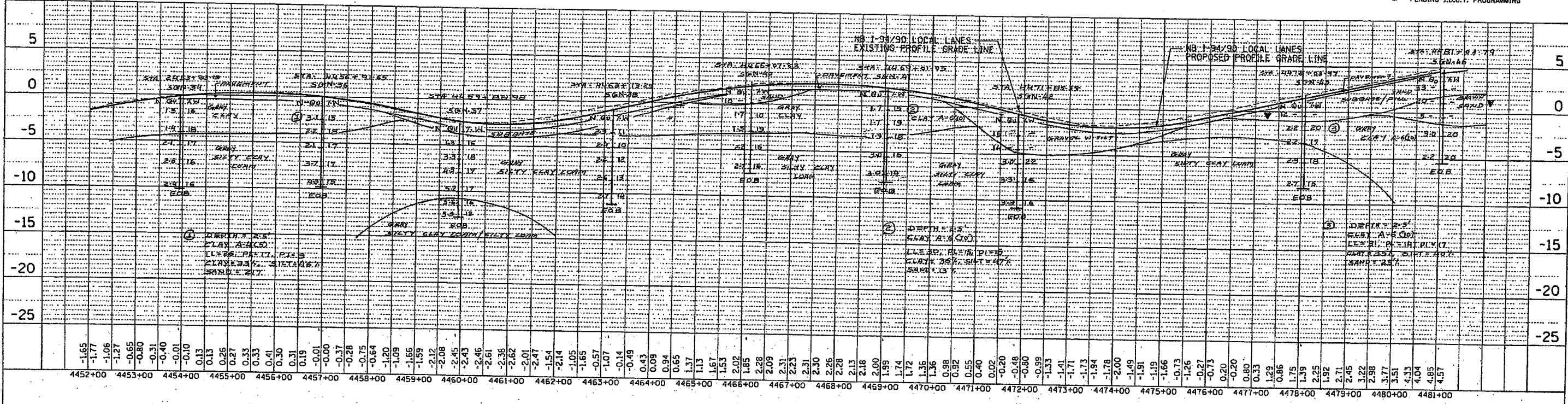

DATE	
BY	
REVISION	
APPROVED	
DATE	
BY	
REVISION	
APPROVED	
DATE	
BY	
REVISION	
APPROVED	

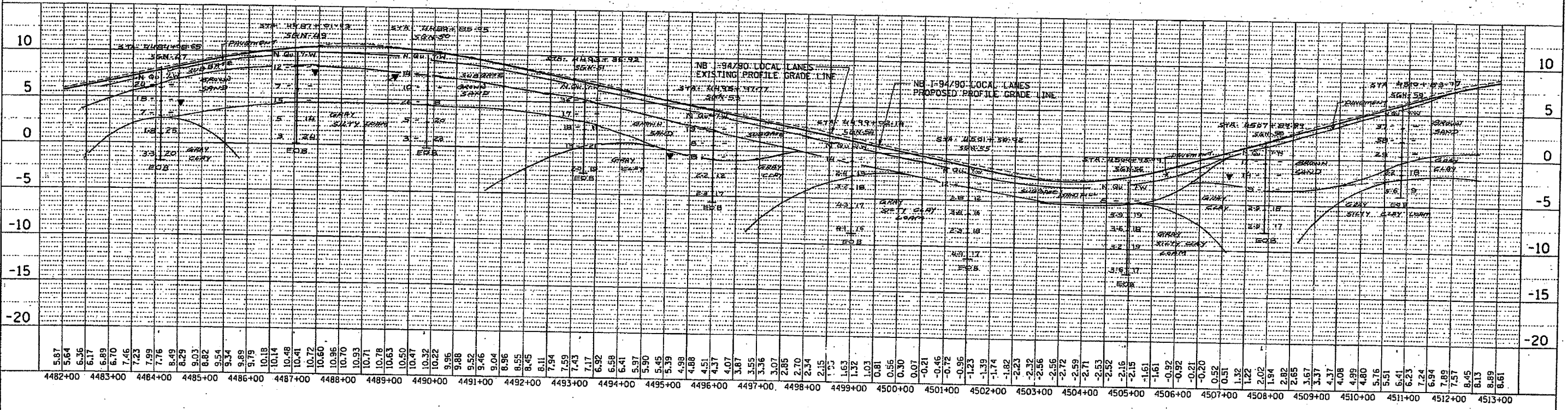

CTE 40256

NB I-94/90 LOCAL LANES PROFILE (STA. 4452+00 TO STA. 4512+00)

SCALE: HORIZ. 1"=100'
VERT. 1"=5'

EXHIBIT NO. 7.3.2

I:\2003\040468\civ\02-dc\sh\soil\pr\0\file\468ex07_03_02.sht
 1/12/2003

PLAN
 DATE
 BY
 CHECKED
 DATE
 BY
 REVISIONS
 NO. DATE DESCRIPTION

PROFILE
 DATE
 BY
 CHECKED
 DATE
 BY
 REVISIONS
 NO. DATE DESCRIPTION

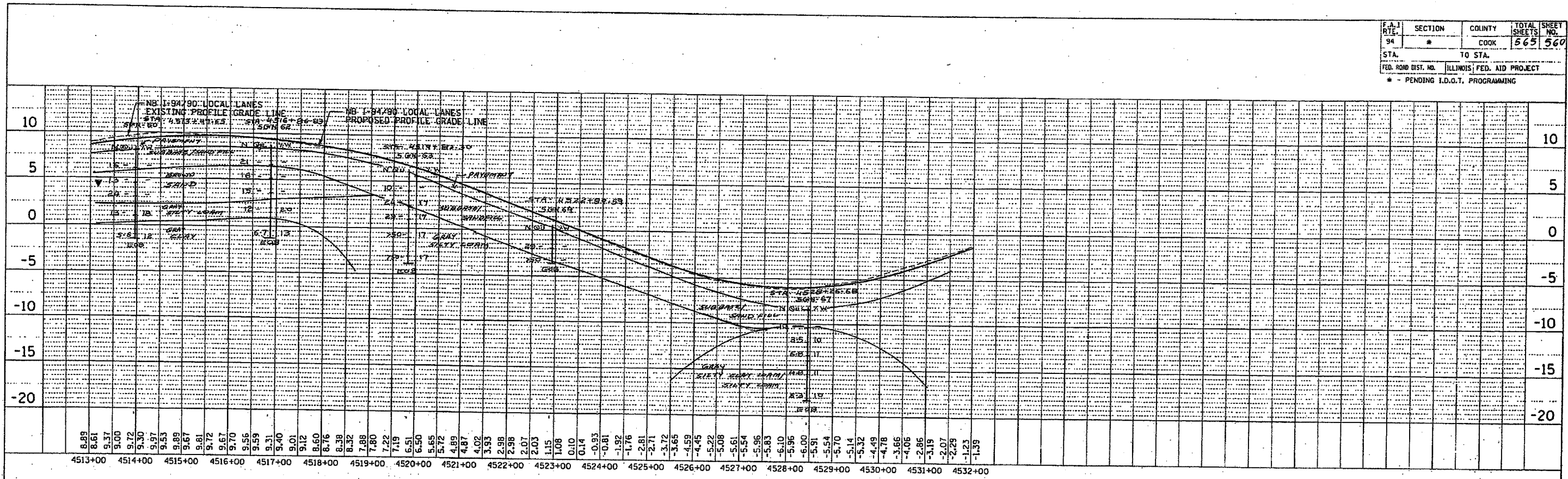

m:\p\0468\civil\02-dc\ent\soil\profile\468xh07_03_03.sht
 11/27/2003

F.A. RTE.	SECTION	COUNTY	TOTAL SHEETS	SHEET NO.
94	*	COOK	566	561
STA.		TO STA.		
FED. ROAD DIST. NO.		ILLINOIS FED. AID PROJECT		
* - PENDING I.D.O.T. PROGRAMMING				

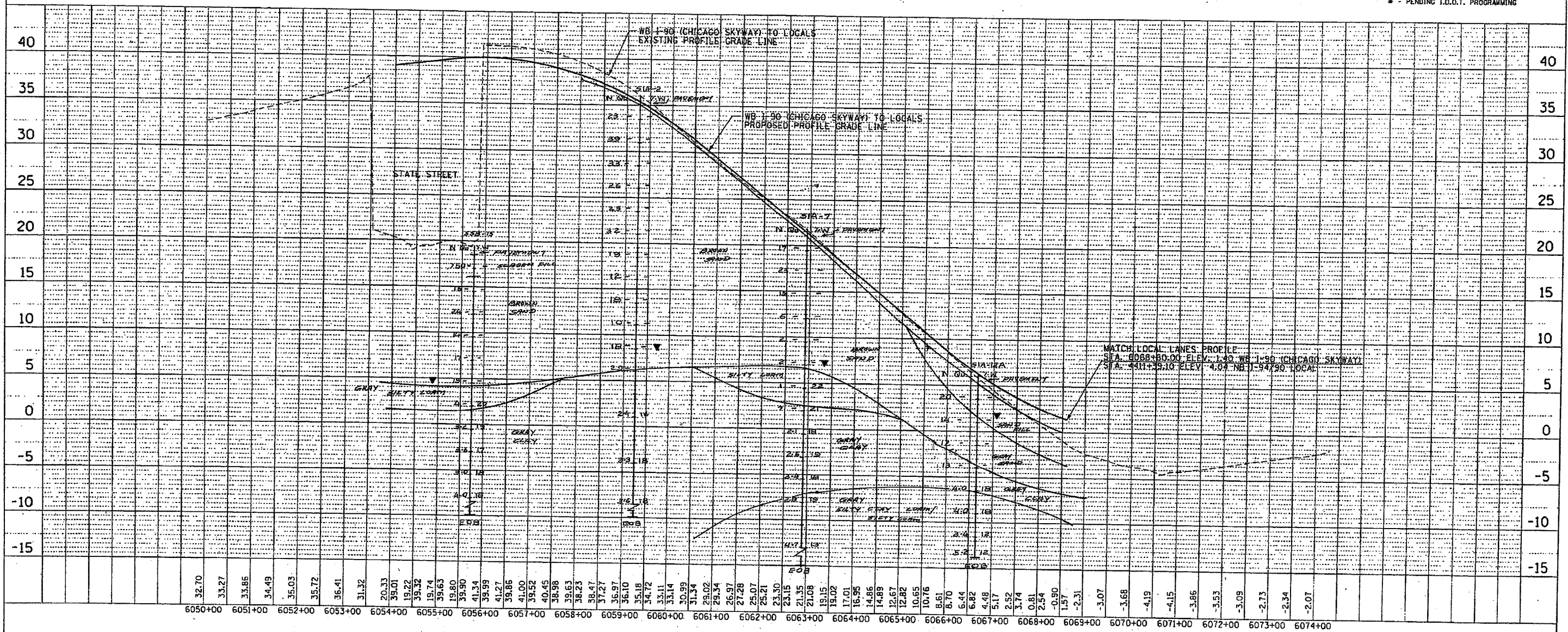

m:\p\40468\civil\02-dc\sh\asol\profile\4856xh07_id_01.sh

DATE	
BY	
PROJECT	
PLANNED	
ALIGNMENT	
PROPOSED	
ROAD FILE NAME	
PLAN	
NOTE BOOK	
NO.	

DATE	
BY	
PROFILE	
PLANNED	
GRADES	
STRUCTURE	
NOTES	
NO.	

CTE 40256

WB I-90 TO I-94/90 RAMP CONNECTION TO LOCAL LANES PROFILE

SCALE: HORIZ. 1"=100'
VERT. 1"=5'

EXHIBIT NO. 7.10.1

F.A. RTE.	SECTION	COUNTY	TOTAL SHEETS	SHEET NO.
94	*	COOK	565	562
STA.	TO STA.			
ILLINOIS FED. AID PROJECT				
* - PENDING I.D.O.T. PROGRAMMING				

DATE	
BY	
CHECKED	
DATE	
APPROVED	
DATE	

DATE	
BY	
CHECKED	
DATE	
APPROVED	
DATE	

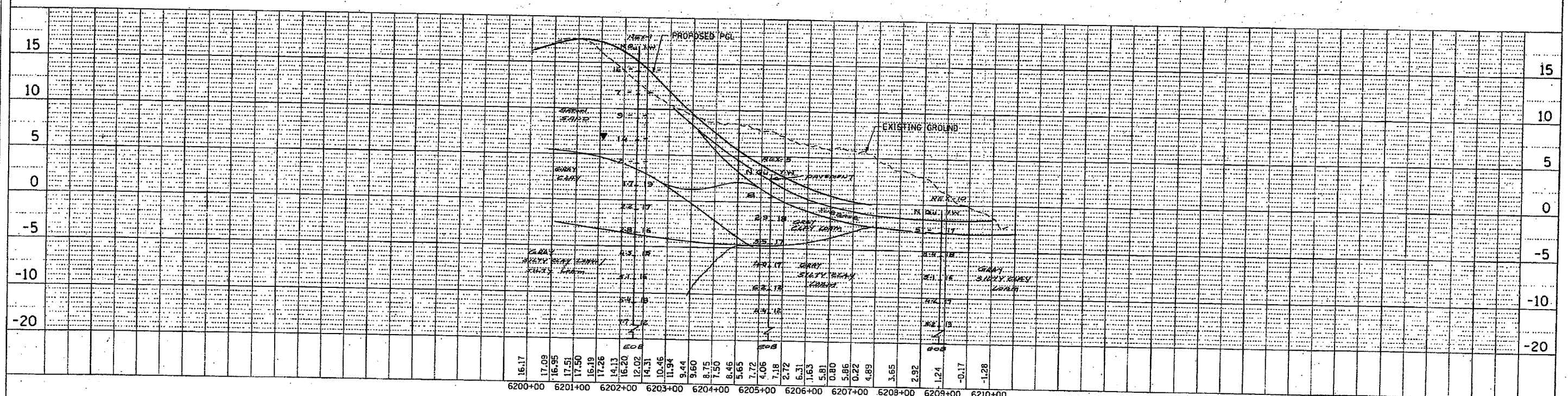
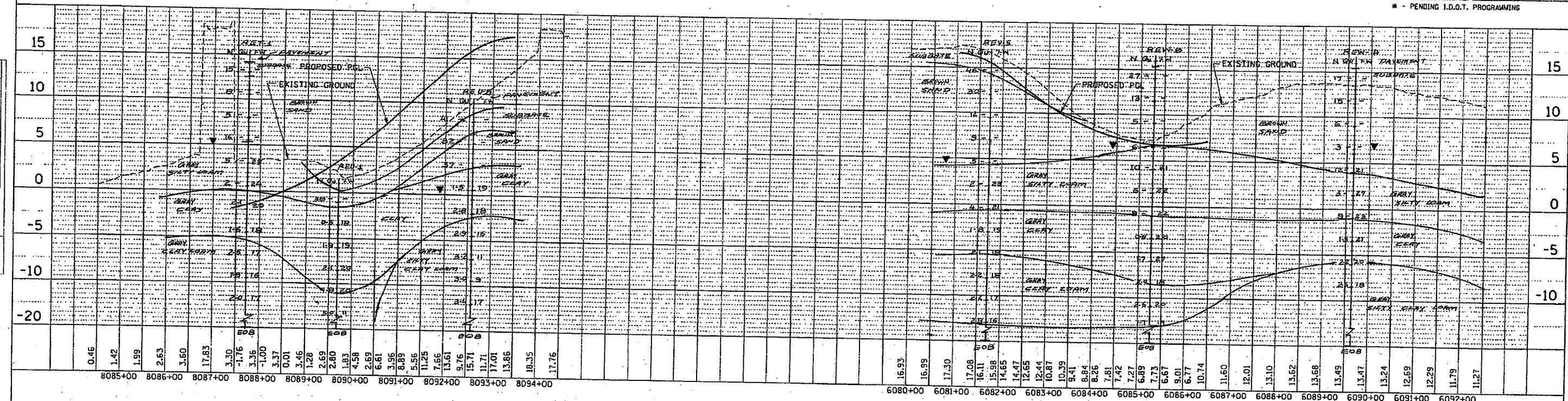

m:\p\40468\civil\02-dc\asht\soilprofile\468ext07_13_04.sht
11/2/2003

CTE 40256

NB RAMP PROFILES

SCALE: HORIZ. 1"=100'
VERT. 1"=5'
EXHIBIT NO. 7.13.4

F.A.J. DATE	SECTION	COUNTY	TOTAL SHEETS	SHEET NO.
94	*	COOK	565	563
STA.	TO STA.			
FED. ROAD DIST. NO.	ILLINOIS FED. AID PROJECT			
* - PENDING I.D.O.T. PROGRAMMING				

PLAN	DATE
PROJECT NO.	
DATE	
BY	
REVISION	
NO.	
DATE	
BY	
REVISION	
NO.	
DATE	

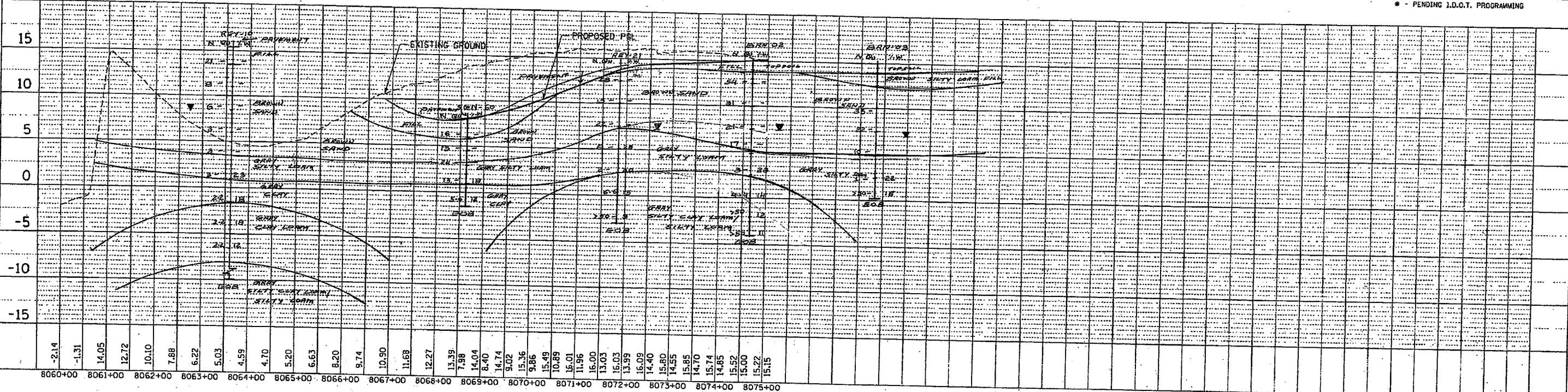

RAMP 47C - NB EXIT TO 47TH STREET

PROFILE	DATE
PROJECT NO.	
DATE	
BY	
REVISION	
NO.	
DATE	
BY	
REVISION	
NO.	
DATE	

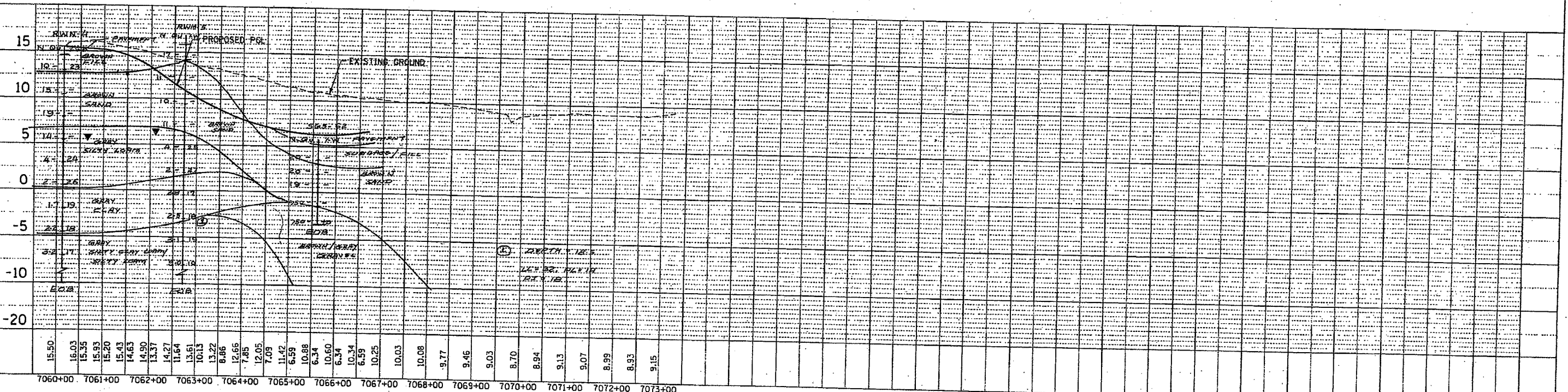

RAMP 47D - SB ENTRANCE RAMP FROM 47TH STREET

CTE 40256

NB AND SB RAMP PROFILES

SCALE: HORIZ. 1"=100'
VERT. 1"=5'
EXHIBIT NO. 7.13.5

m:\p\40466\civil\02-dc\sh\soil\profile\468exn07_13_05.shp
1/27/2003

F.A. DIST. NO.	SECTION	COUNTY	TOTAL SHEETS	SHEET NO.
94	*	COOK	565	564
STA.	TO STA.			
FED. ROAD DIST. NO.	ILLINOIS	FED. AID PROJECT		
* - PENDING I.D.O.T. PROGRAMMING				

DATE	BY
REVISION	NO.
1	
2	
3	
4	
5	
6	
7	
8	
9	
10	
11	
12	
13	
14	
15	
16	
17	
18	
19	
20	
21	
22	
23	
24	
25	
26	
27	
28	
29	
30	

DATE	BY
REVISION	NO.
1	
2	
3	
4	
5	
6	
7	
8	
9	
10	
11	
12	
13	
14	
15	
16	
17	
18	
19	
20	
21	
22	
23	
24	
25	
26	
27	
28	
29	
30	

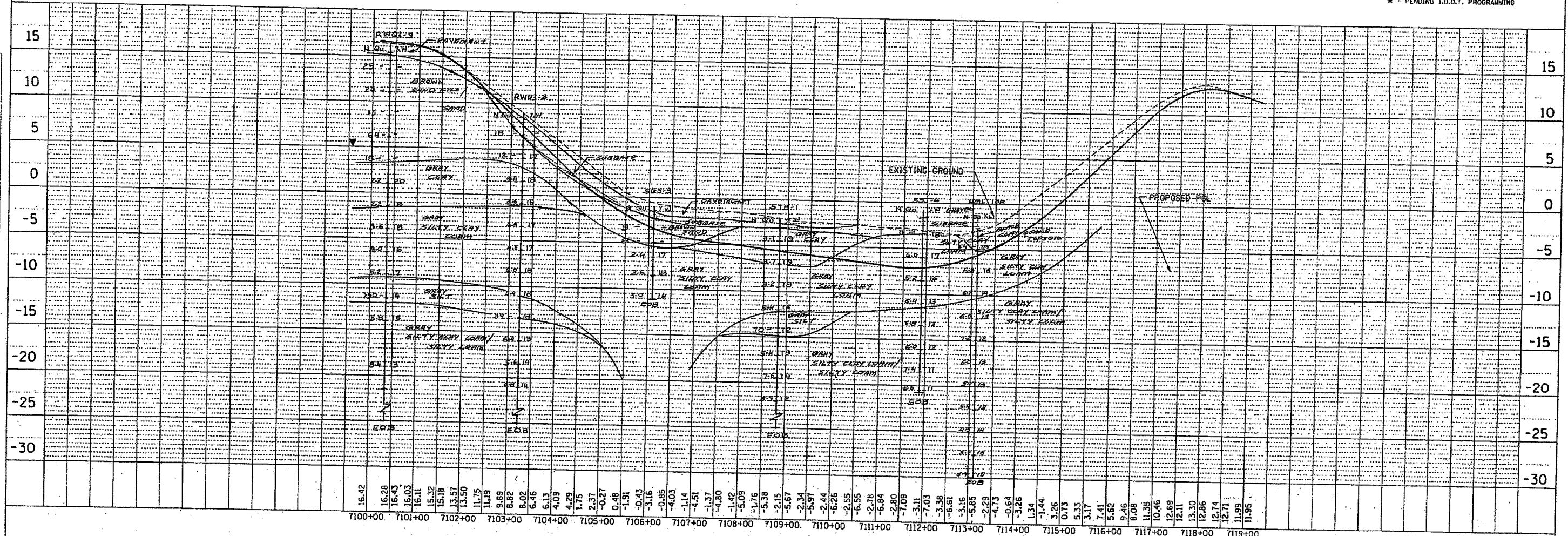

RAMP 67D71A - SB COLLECTOR - DISTRIBUTOR ROAD BETWEEN 71ST AND 67TH STREETS

M:\p0468\civil\02-dc\sh\1\profile\468exh07_14_04.sht 11/2/2003

CTE 40256

SB RAMP PROFILES

SCALE: HORIZ. 1"=100'
VERT. 1"=5' EXHIBIT NO. 7.14.4

P.A.I. SHEET NO.	SECTION	COUNTY	TOTAL SHEETS	SHEET NO.
94	*	COOK	565	565
STA.	TO STA.			
FED. ROAD DIST. NO. ILLINOIS FED. AID PROJECT				
* - PENDING I.D.O.T. PROGRAMMING				

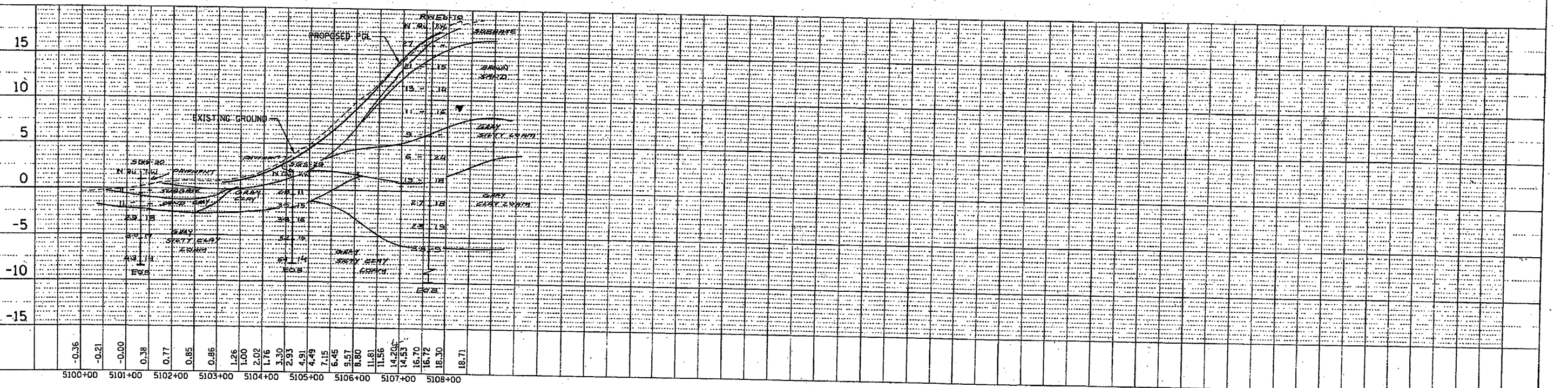
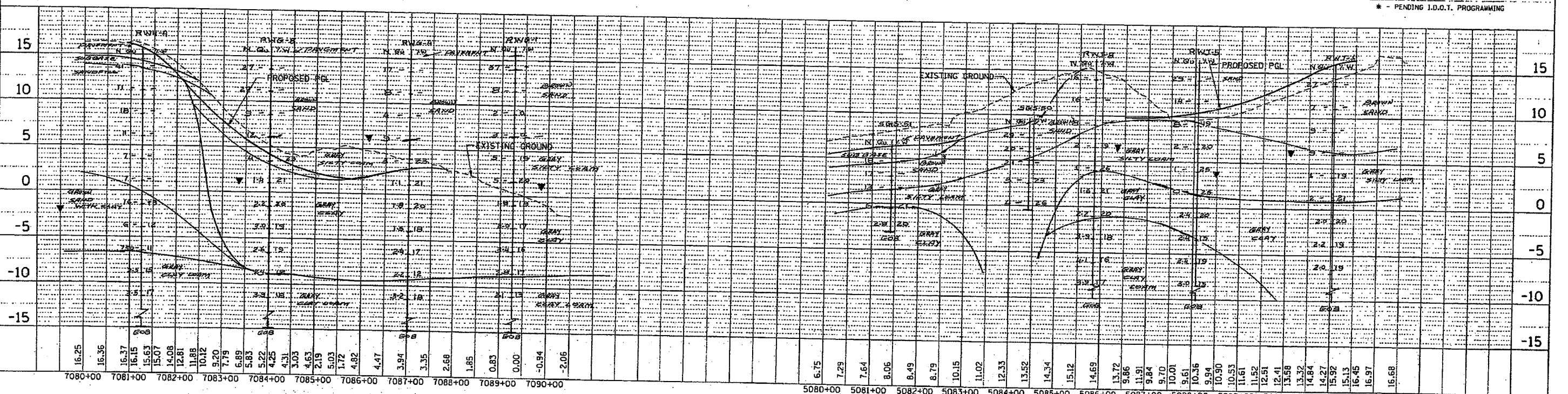

DATE	BY	REVISION

DATE	BY	REVISION

m:\p40468\civil\02-dc\shl\soil\profile\468xh07_14_05.sht
11/27/2003

CTE 40256

SB RAMP PROFILES

SCALE: HORIZ. 1"=100'
VERT. 1"=5'

EXHIBIT NO. 7.14.5