

F.A. RTE.	SECTION	COUNTY	TOTAL SHEETS	SHEET NO.
			588	501
STA.		TO STA.		
FED. ROAD DIST. NO.		ILLINOIS FED. AID PROJECT		

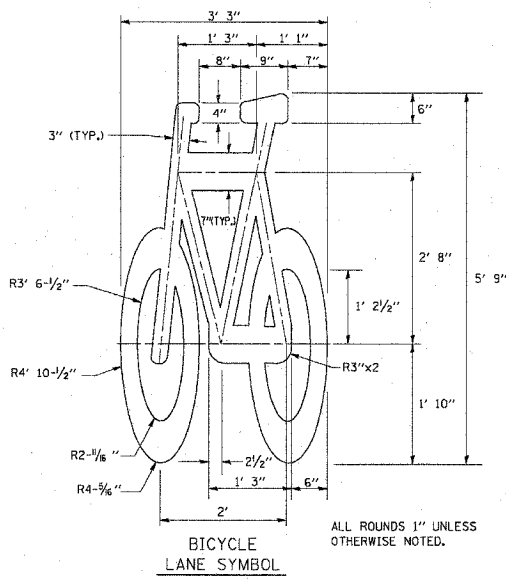
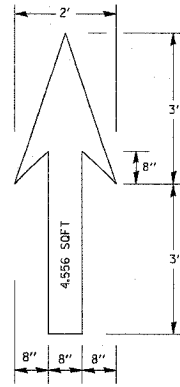

NOTE:
 1.) FOR BIKE LANE SYMBOLS ONLY, USE PRE-FORMED THERMOPLASTIC WITH A MINIMUM THICKNESS OF 90 MILS, MINIMUM SKID RESISTANCE VALUE OF 60 BPN, & A MINIMUM INDEX OF REFRACTION OF 1.50.
 2.) THE RESIDENT ENGINEER SHALL CONTACT MR. BEN COMBERG AT 312-744-8093 AT LEAST ONE CALENDAR WEEK PRIOR TO INSTALLING BIKE LANE SYMBOLS.

TYPICAL BIKE LANE SYMBOLS
DRAWING #28

DRAWING #29

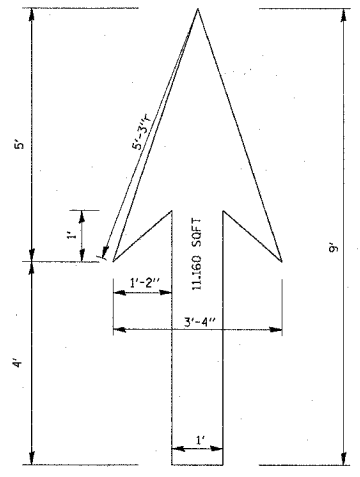

DRAWING #30

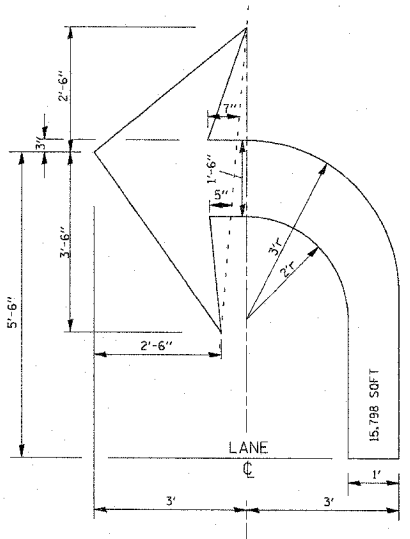

DRAWING #31

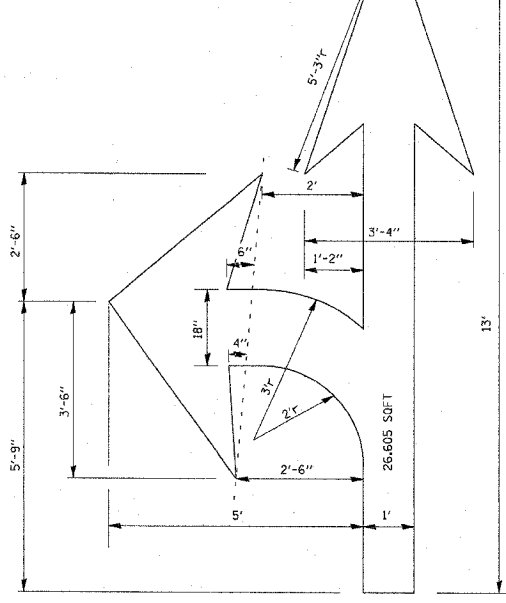

DRAWING #32

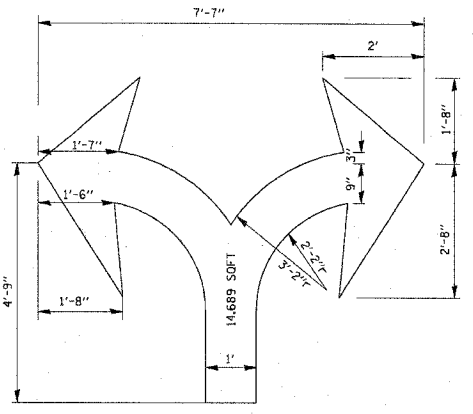

DRAWING #33

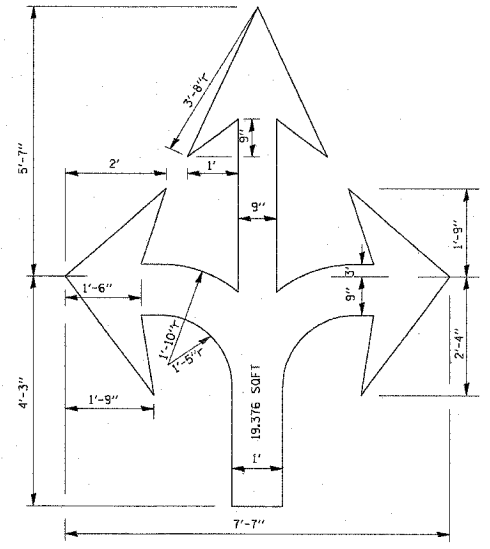

DRAWING #34

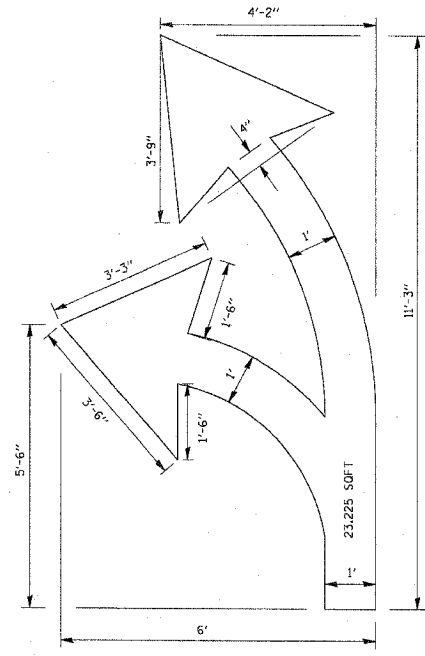

DRAWING #35

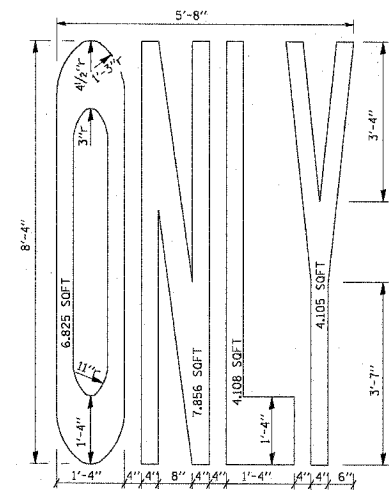

NOTE:
 ALL MARKINGS SHALL BE SOLID WHITE UNLESS OTHERWISE NOTED IN THE PLANS

REVISIONS	
NAME	DATE
T. RAMMACHER	12/07/00

ILLINOIS DEPARTMENT OF TRANSPORTATION
 CITY OF CHICAGO
 TYPICAL PAVEMENT MARKINGS.

SCALE: NONE
 DATE 03/09/2004
 DRAWN BY
 CHECKED BY
 TC-24

FINAL SURVEY	DATE
NO. _____	BY _____
PLOTTED	
TEMPLATE	
AREAS CHECKED	

ORIGINAL SURVEY	DATE
NO. _____	BY _____
PLOTTED	
TEMPLATE	
AREAS CHECKED	

CTE | AECOM

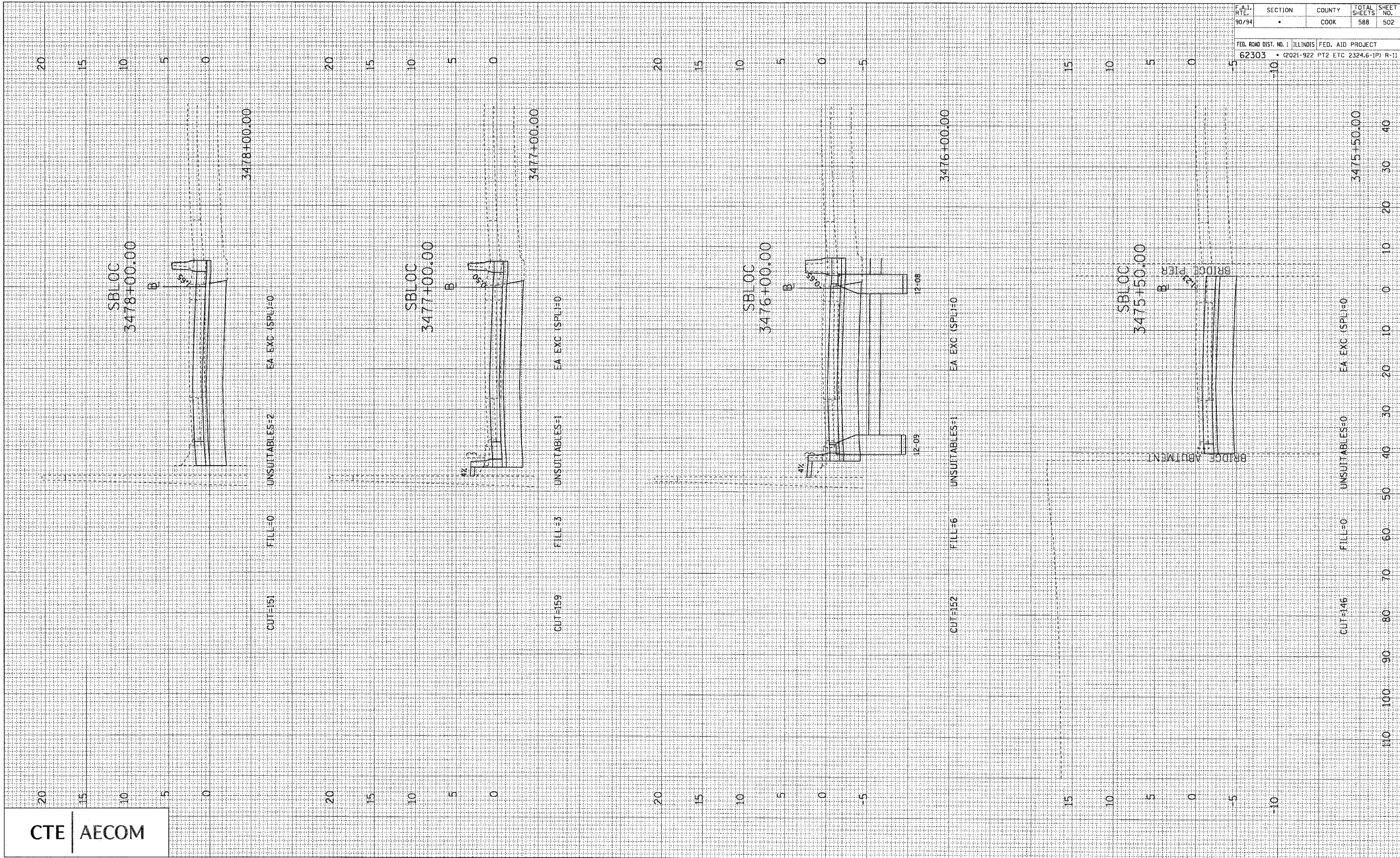

F.A.I. RITE	SECTION	COUNTY	TOTAL SHEETS	SHEET NO.
90/94	•	COOK	588	502
FED. ROAD DIST. NO. 1 ILLINOIS FED. AID PROJECT				
62303 • (2021-922 PT2 ETC 2324.6-1P) R-11				

6/7/2006 1:34:38 PM P:\P40462\CH\WB-Cross & @SMA\Ch\B\Cross Sections\X95_SBLOC_2.dwg

FINAL SURVEY	SUBMITTED	BY	DATE
NOTE BOOK	PLOTTED		
NO.	TEMPLATE		
	AREAS CHECKED		

ORIGINAL SURVEY	SUBMITTED	BY	DATE
NOTE BOOK	PLOTTED		
NO.	TEMPLATE		
	AREAS CHECKED		

CTE | AECOM

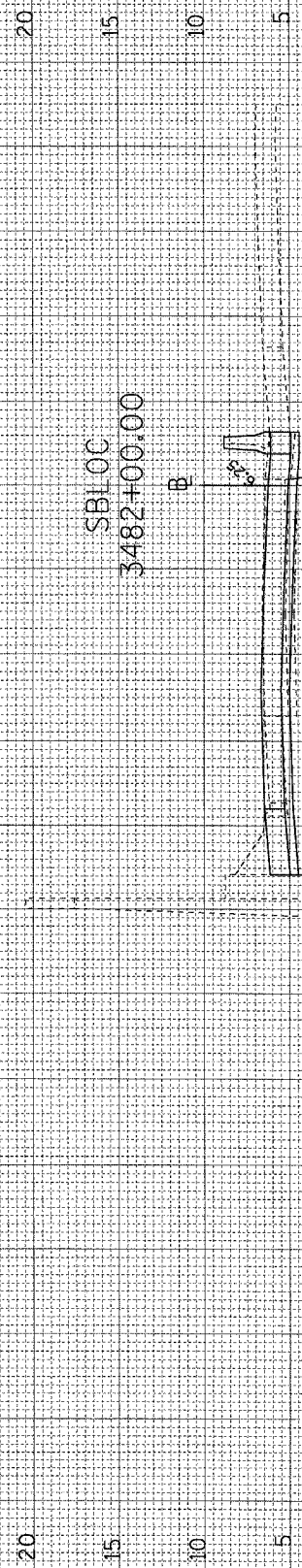

3482+00.00

EA EXC (SPL)=0

UNSUITABLES=3

FILL=0

CUT=135

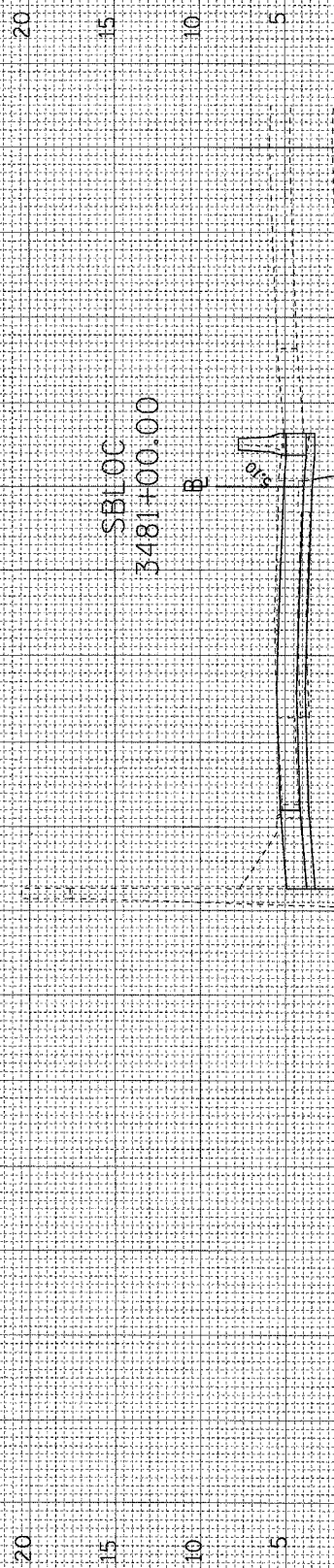

3481+00.00

EA EXC (SPL)=0

UNSUITABLES=4

FILL=0

CUT=152

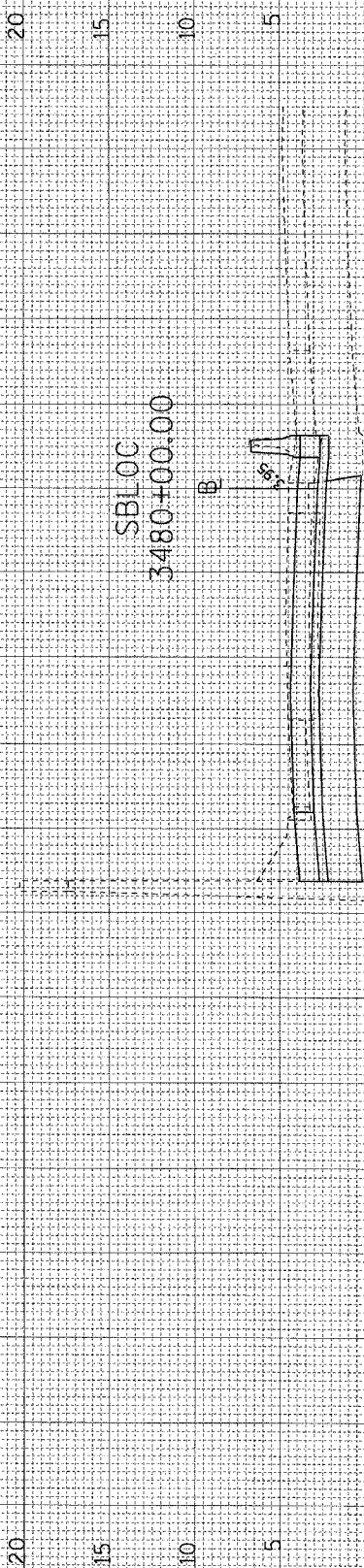

3480+00.00

EA EXC (SPL)=0

UNSUITABLES=4

FILL=0

CUT=155

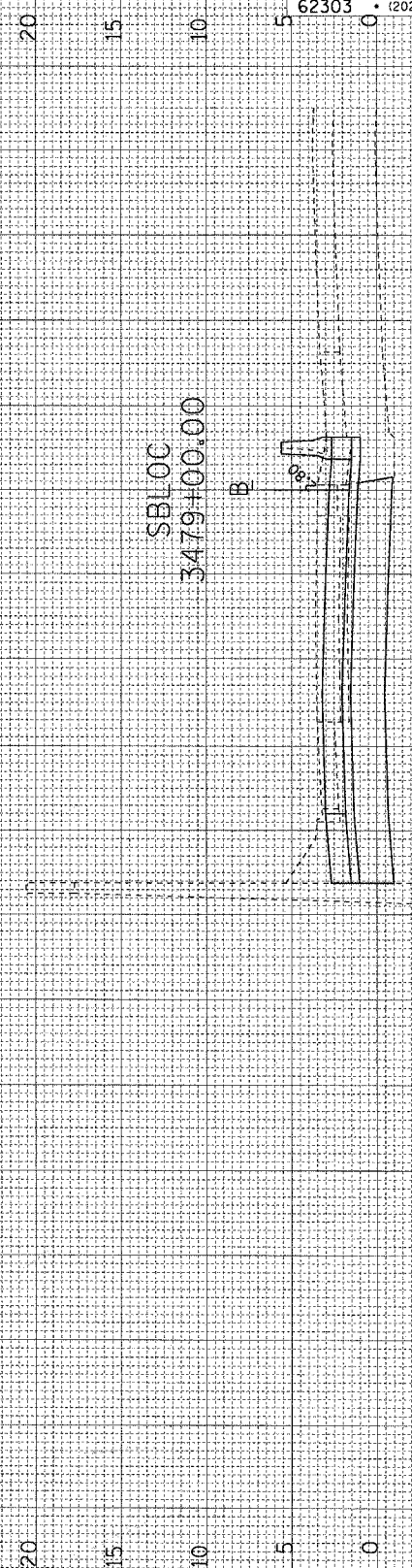

3479+00.00

EA EXC (SPL)=0

UNSUITABLES=4

FILL=0

CUT=162

F.A.I. RTE.	SECTION	COUNTY	TOTAL SHEETS	SHEET NO.
90/94	•	COOK	588	503
FED. ROAD DIST. NO. 1 ILLINOIS FED. AID PROJECT				
62303 • (2021-922 PT2 ETC 2324.6-1P) R-11				

P:\P40465\DWG\Cmts B & 15\SA\CMT 19\Cross Sections\19_SBloc_2021.rvt 6/7/2026 1:31:41 PM

ORIGINAL SURVEY PLOTTED TEMPLATE AREAS CHECKED
 BY: _____ DATE: _____
 NO. _____

FINAL SURVEY PLOTTED TEMPLATE AREAS CHECKED
 BY: _____ DATE: _____
 NO. _____

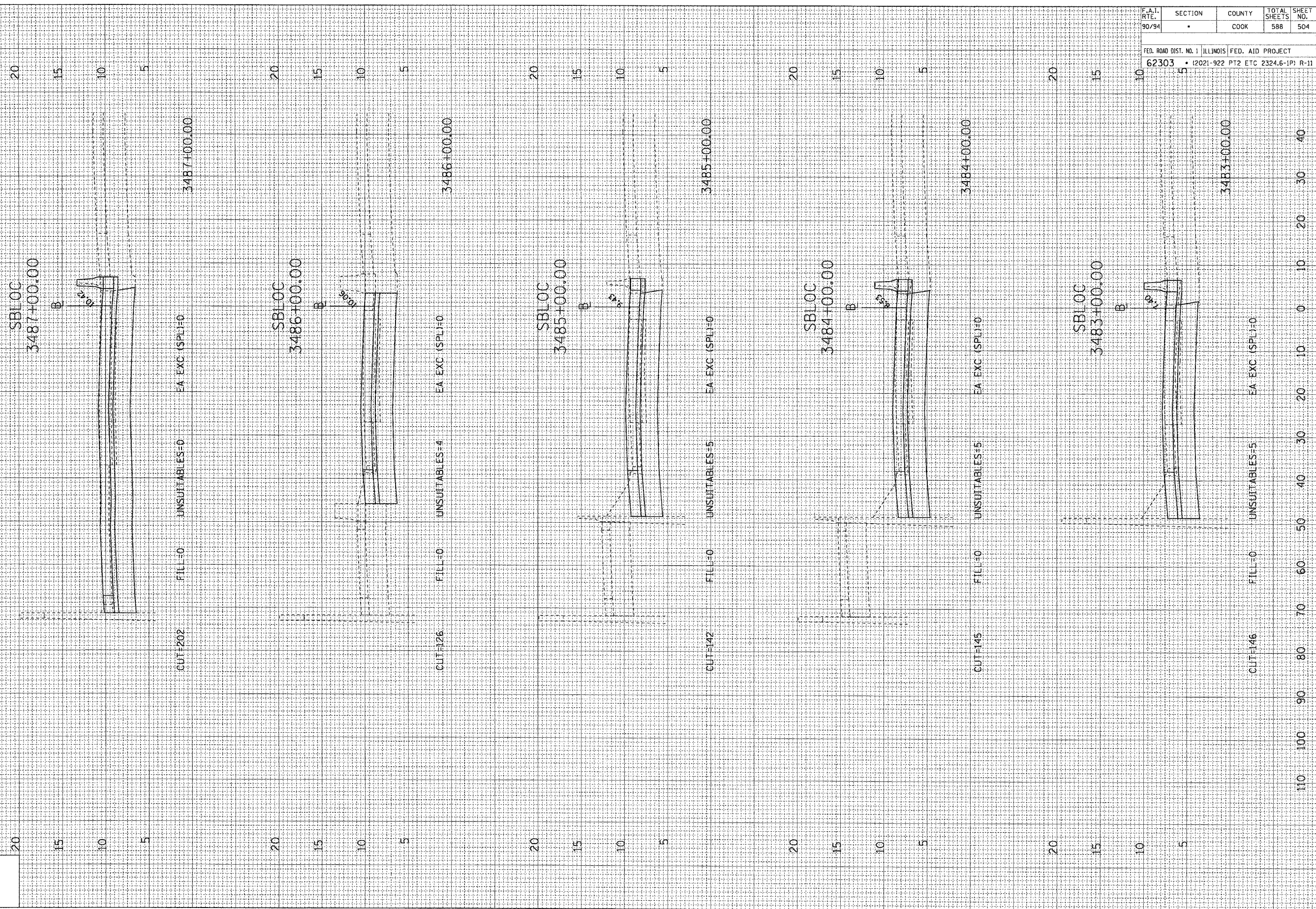

F.A.I. RT. 90/94	SECTION	COUNTY COOK	TOTAL SHEETS 588	SHEET NO. 504
FED. ROAD DIST. NO. 1 ILLINOIS FED. AID PROJECT 62303 (2021-922 PT2 ETC 2324.6-1P) R-11				

FINAL SURVEY	DATE
BY	
NO.	
APPROVED	DATE
BY	
NO.	
PLOTTED	DATE
BY	
NO.	
TEMPLATE	DATE
BY	
NO.	
AREAS	DATE
CHECKED	

ORIGINAL SURVEY	DATE
BY	
NO.	
APPROVED	DATE
BY	
NO.	
PLOTTED	DATE
BY	
NO.	
TEMPLATE	DATE
BY	
NO.	
AREAS	DATE
CHECKED	

F.A.I. RTE.	SECTION	COUNTY	TOTAL SHEETS	SHEET NO.
90/94		COOK	588	506
FED. ROAD DIST. NO. 1 ILLINOIS FED. AID PROJECT				
62303 • (2021-922 PT2 ETC 2324.6-1P) R-11				

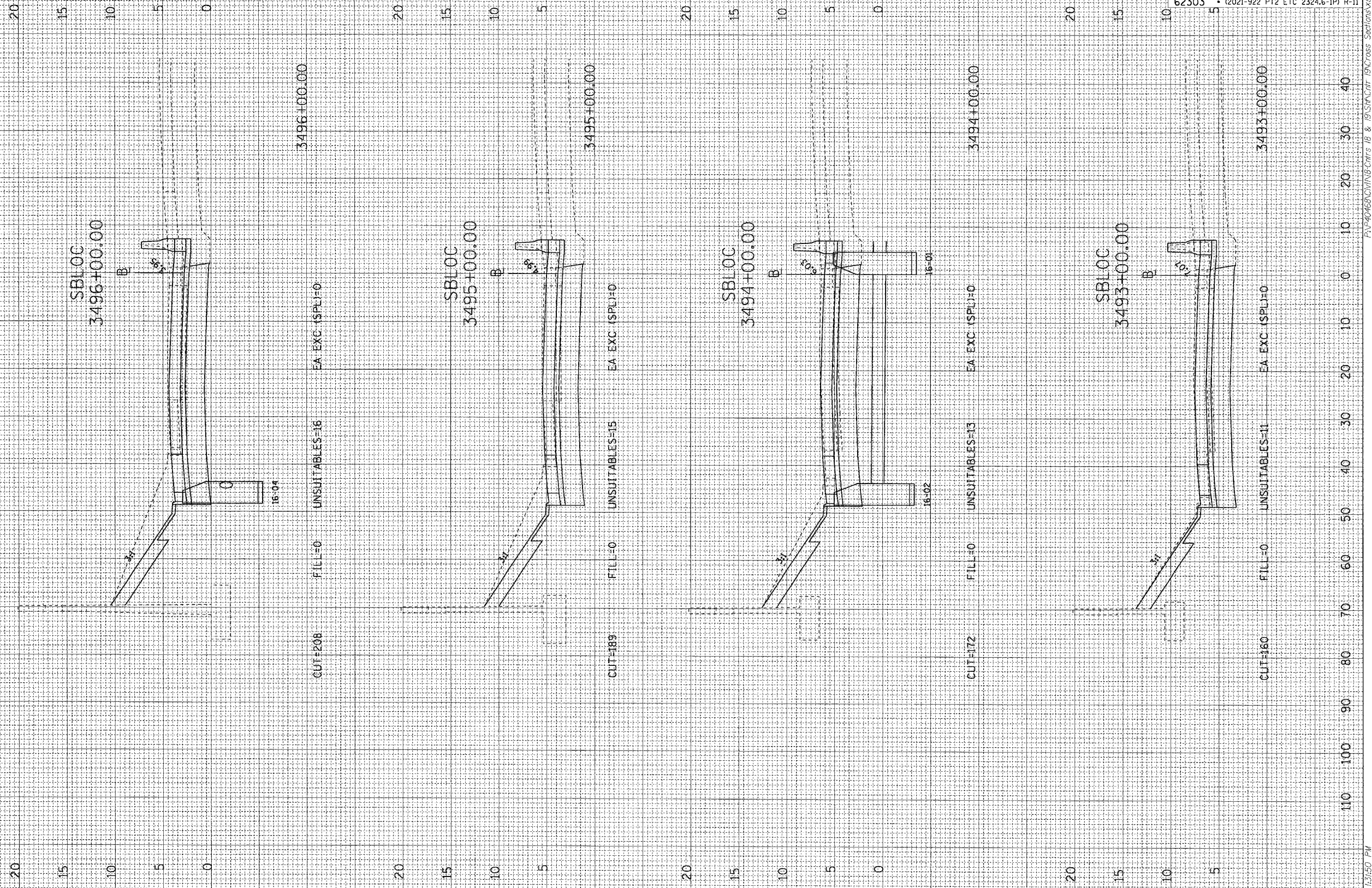

6/7/2005 1:50 PM
 PLAN=40468/CHINA-CARRS 16 & 19/ST/CRIT 19/Cross Sections/589_SMOG_2021.rvt

FINAL SURVEY	REVISED	DATE
NO. _____	BY _____	_____
PLANNING	DESIGNED	
ENGINEERING	CHECKED	
CONSTRUCTION	APPROVED	

ORIGINAL SURVEY	REVISED	DATE
NO. _____	BY _____	_____
PLANNING	DESIGNED	
ENGINEERING	CHECKED	
CONSTRUCTION	APPROVED	

CTE | AECOM

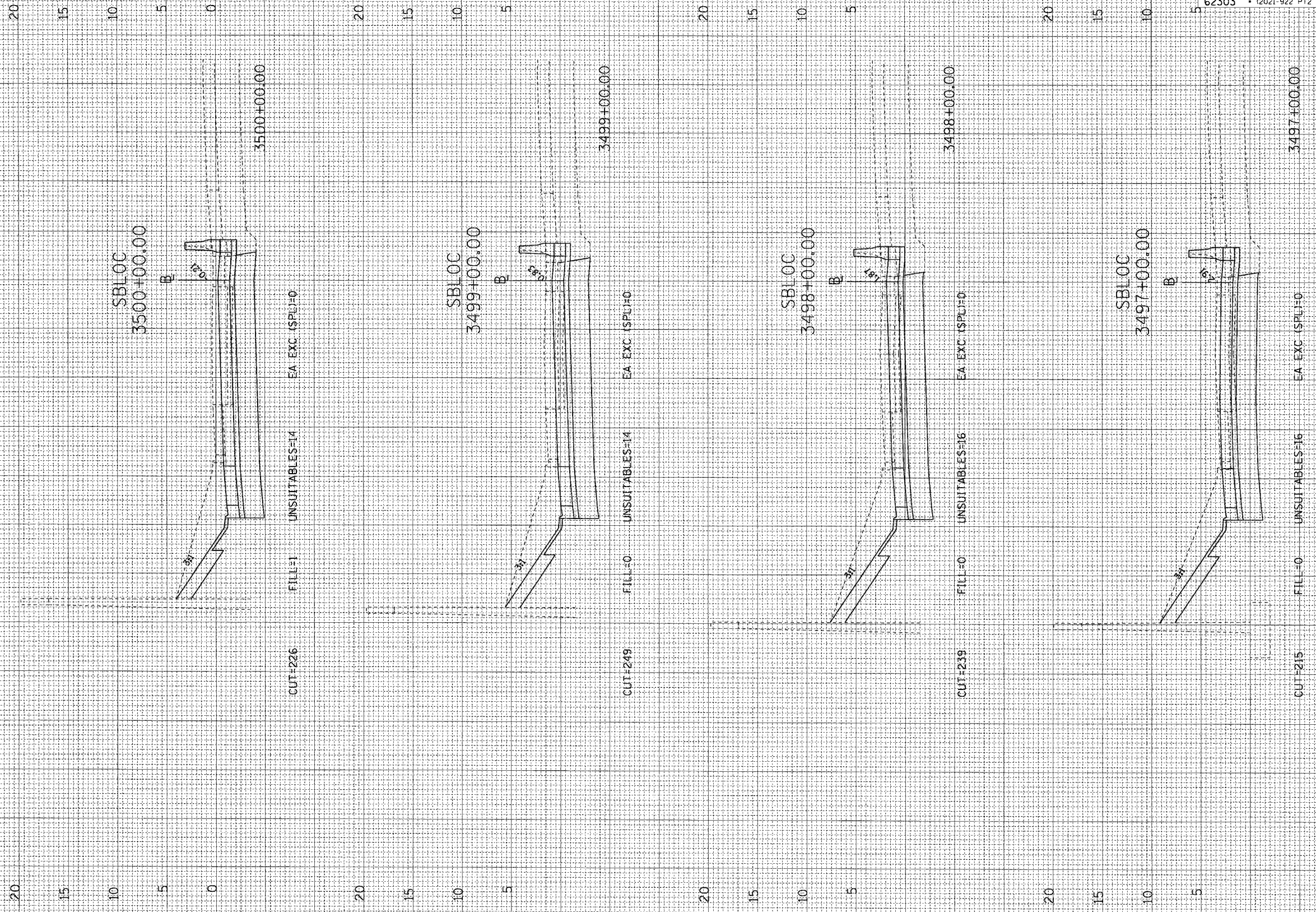

F.A.I. RTE.	SECTION	COUNTY	TOTAL SHEETS	SHEET NO.
90/94	•	COOK	588	507
FED. ROAD DIST. NO. 1 ILLINOIS FED. AID PROJECT				
62303 • (2021-922 PT2 ETC 2324.6-1P) R-11				

6/7/2006 13:52 PM F:\P\068\GWIN\B-Cars 18 & 19\SMC\19\Cross Sections\519_sblloc_2a.dwg

CTE | AECOM

FINAL SURVEY NO.	SURVEY PLOTTED	DATE
NOTE BOOK NO.	TEMPLATE AREAS CHECKED	

ORIGINAL SURVEY NO.	SURVEY PLOTTED	DATE
NOTE BOOK NO.	TEMPLATE AREAS CHECKED	

F.A.I. RTE.	SECTION	COUNTY	TOTAL SHEETS	SHEET NO.
90/94		COOK	588	508
FED. ROAD DIST. NO. 1 ILLINOIS FED. AID PROJECT				
62303 • (2021-922 PT2 ETC 2324.6-1P) R-11				

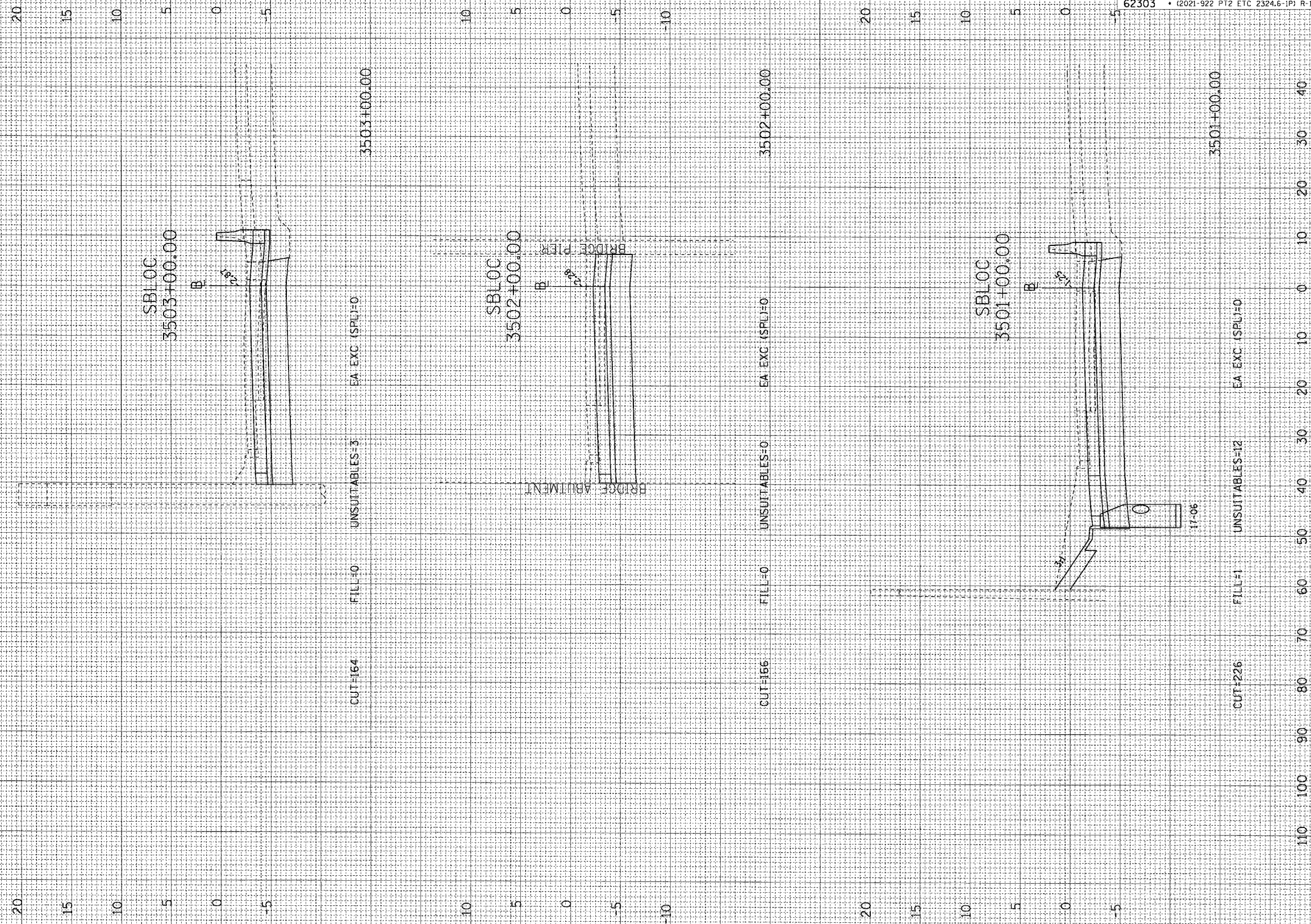

6/7/2006 13:55 PM P:\40465\G1718-Ctrls B & 15\SM\CTR 15\Cross Sections\619_SBOC_21.DWG

FINAL SURVEY	FORWARDED	DATE
NOTE BOOK	PLOTTED	BY
NO.	TEMPLATE	
	AREAS	
	CHECKED	

ORIGINAL SURVEY	FORWARDED	DATE
NOTE BOOK	PLOTTED	BY
NO.	TEMPLATE	
	AREAS	
	CHECKED	

CTE | AECOM

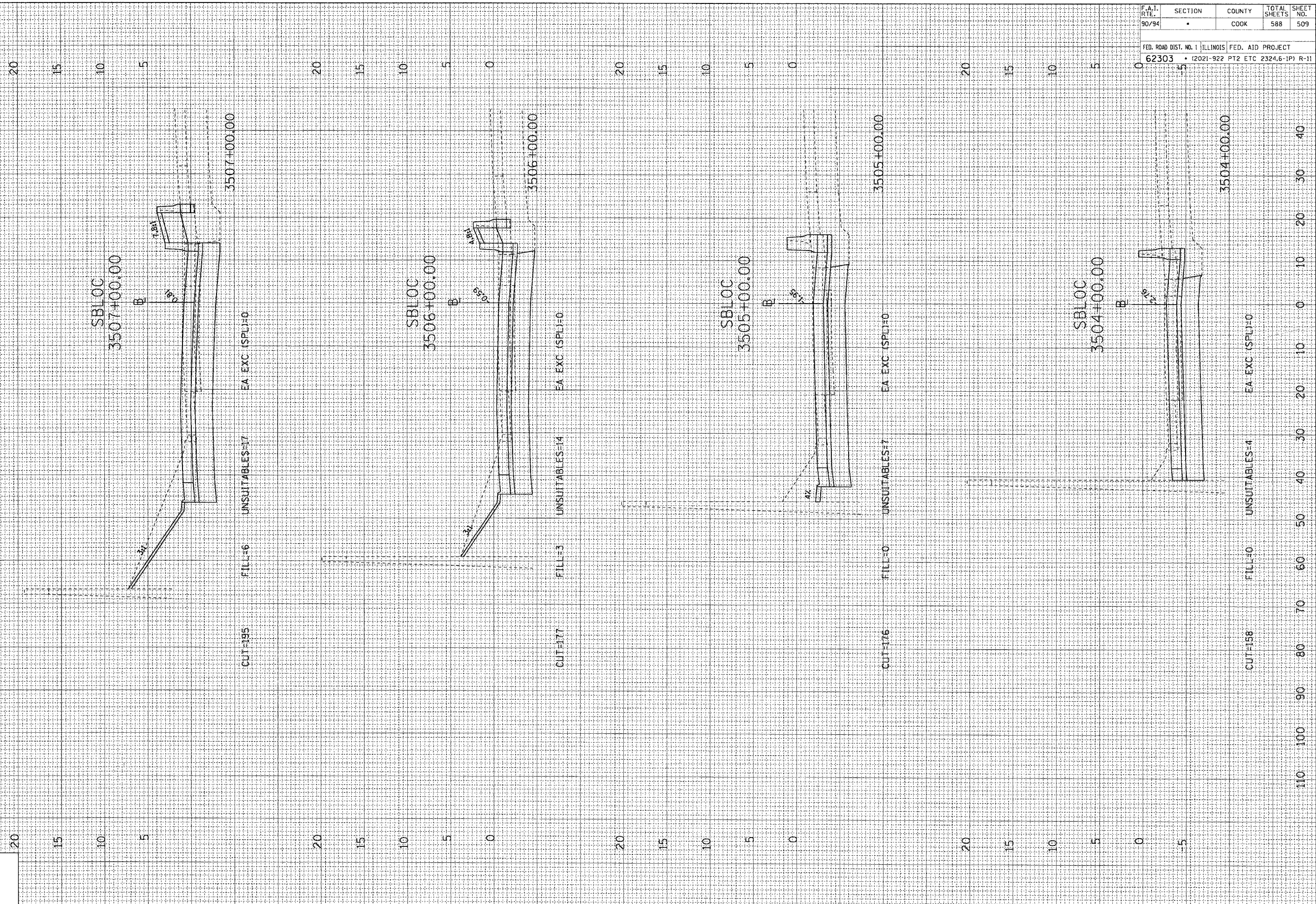

F.A.I. RTE.	SECTION	COUNTY	TOTAL SHEETS	SHEET NO.
90/94		COOK	588	509
FED. ROAD DIST. NO. 1 ILLINOIS FED. AID PROJECT				
62303 • (2021-922 PT2 ETC 2324.6-1P) R-11				

6/7/2006 1:558 PM P:\40468\Garfield-Centrs 18 & 19\31stCntr 19\Cross Sections\69_SbLoc_2a.dwg

FINAL SURVEY CONVERSIONS
 SURVEY PLOTTED BY DATE
 NOTE BOOK TEMPLATE AREAS CHECKED
 NO. AREAS CHECKED

ORIGINAL SURVEY CONVERSIONS
 SURVEY PLOTTED BY DATE
 NOTE BOOK TEMPLATE AREAS CHECKED
 NO. AREAS CHECKED

CTE | AECOM

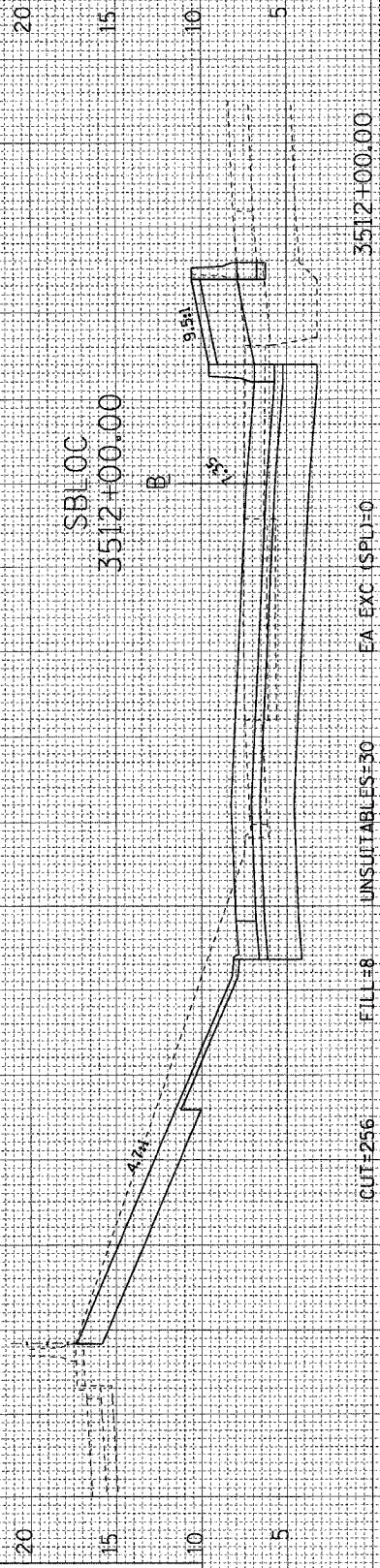

CUT=256 FILL=8 UNSUITABLES=30 EA_EXC (SPL)=0 3512+00.00

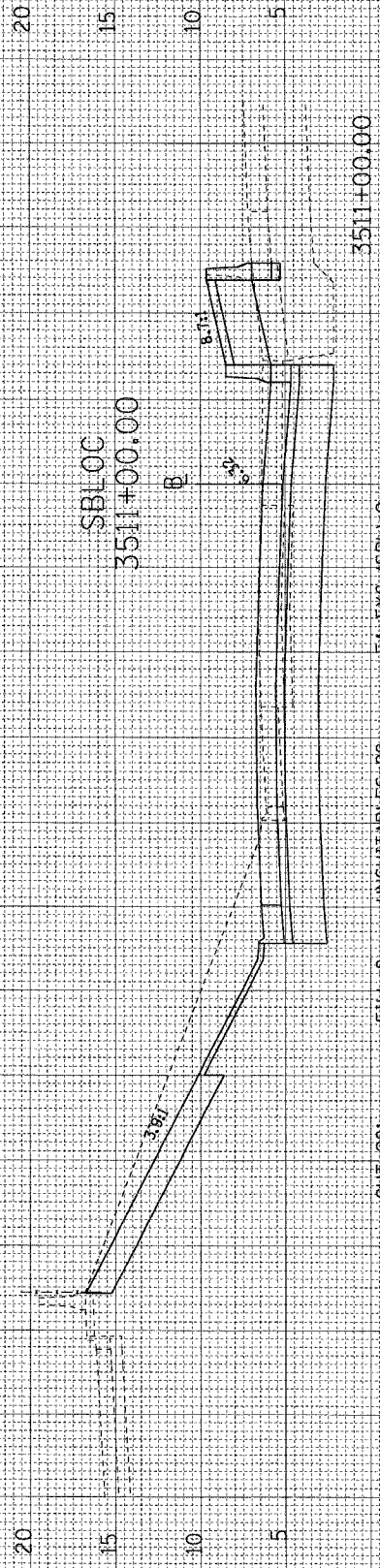

CUT=28 FILL=8 UNSUITABLES=28 EA_EXC (SPL)=0 3511+00.00

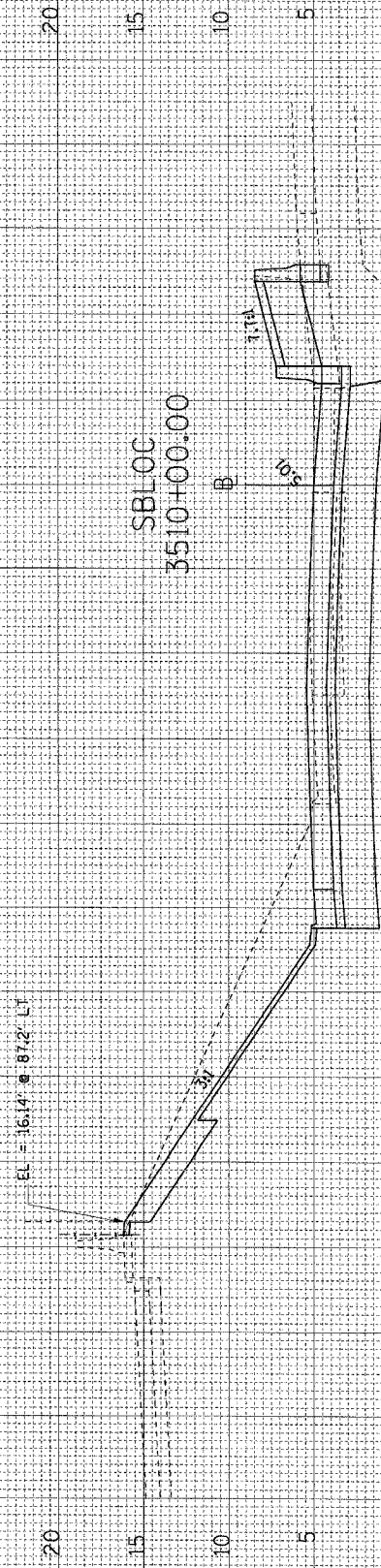

CUT=266 FILL=8 UNSUITABLES=26 EA_EXC (SPL)=0 3510+00.00

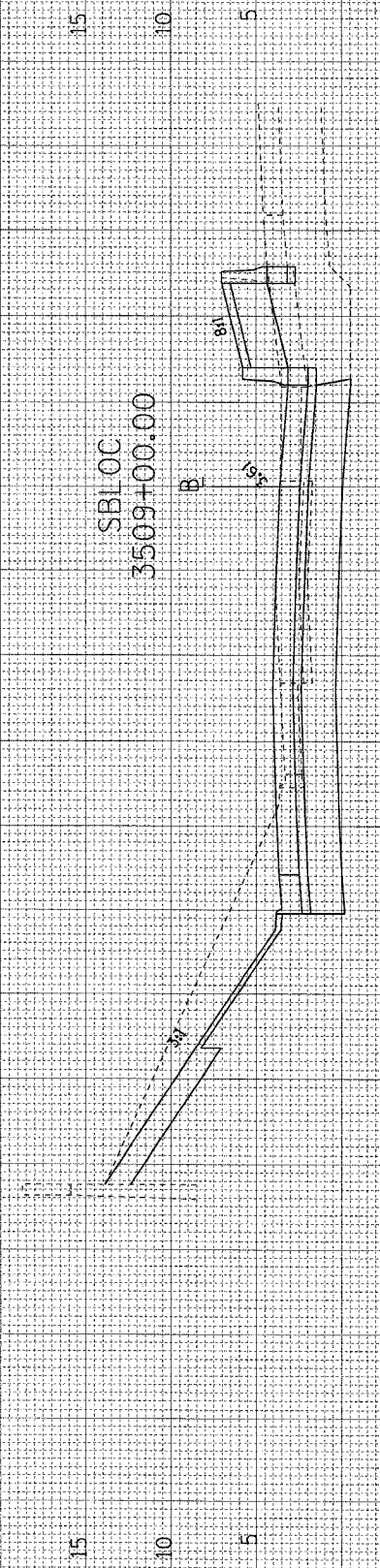

CUT=255 FILL=8 UNSUITABLES=23 EA_EXC (SPL)=0 3509+00.00

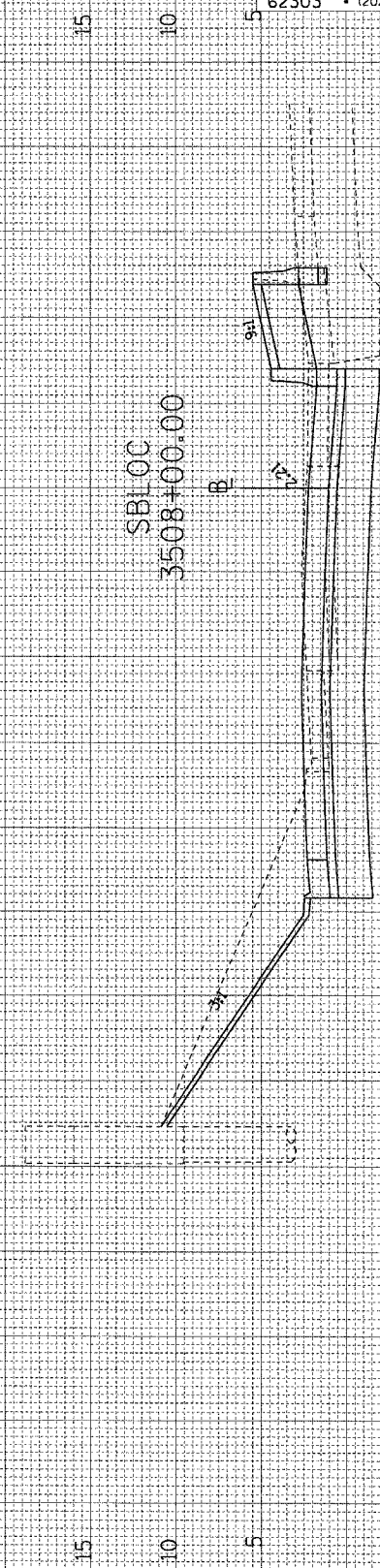

CUT=245 FILL=8 UNSUITABLES=21 EA_EXC (SPL)=0 3508+00.00

F.A.I. RTE.	SECTION	COUNTY	TOTAL SHEETS	SHEET NO.
90/94		COOK	588	510

FED. ROAD DIST. NO. 1	ILLINOIS	FED. AID PROJECT
62303		(2021-922 PT2 ETC 2324.6-1P) R-11

6/7/2006 6:32:00 PM P:\P40468\CONTR-Cross 18 & 19\STATION 19\Cross sections\18_SBLoc_21.dwg

FINAL SURVEY COMMENTED PLOTTED DATE
 NO. SURVEY BOOK TEMPLATE AREAS CHECKED

ORIGINAL SURVEY COMMENTED PLOTTED DATE
 NO. SURVEY BOOK TEMPLATE AREAS CHECKED

CTE | AECOM

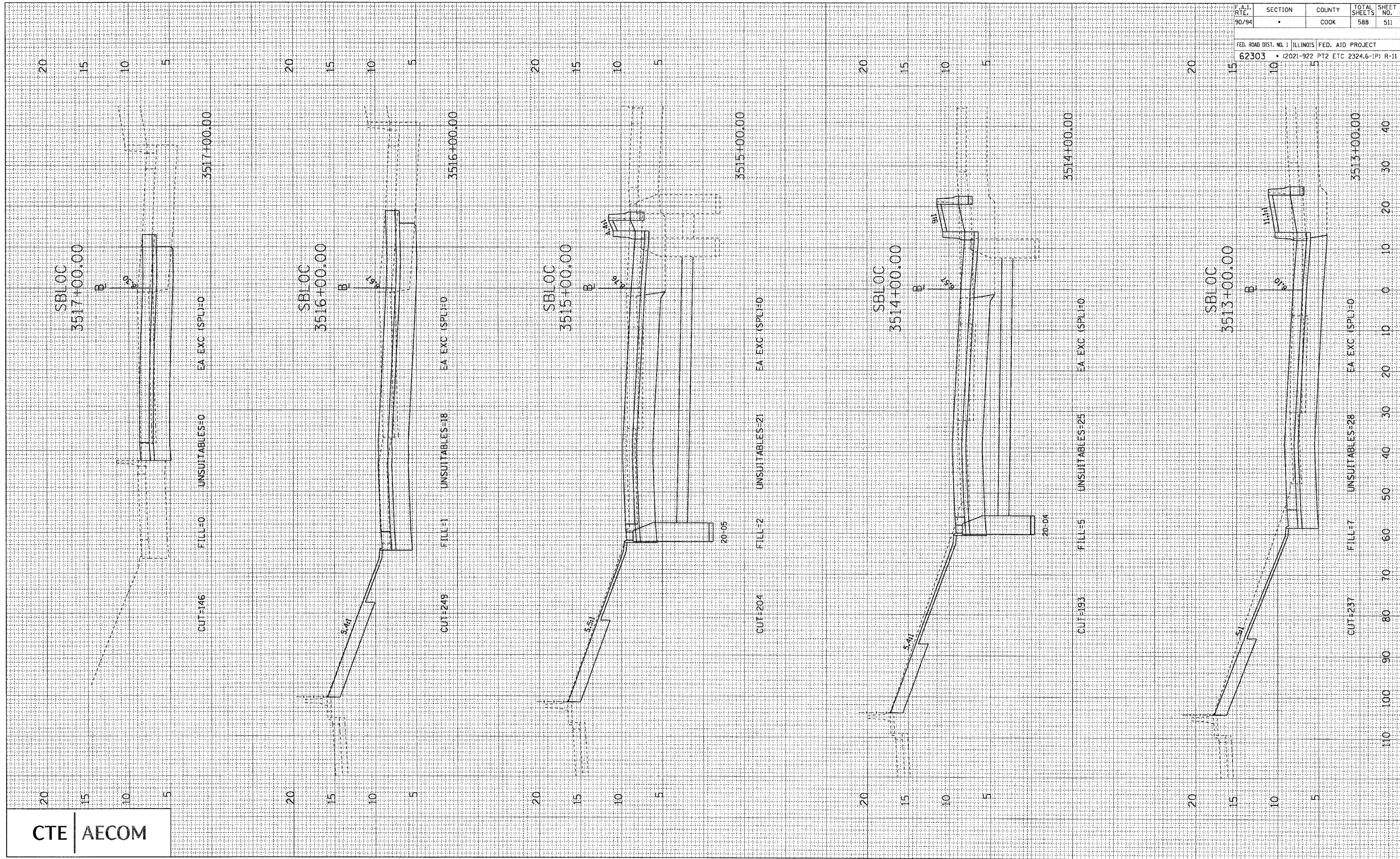

F.A.I. RT. 90/94	SECTION	COUNTY	TOTAL SHEETS	SHEET NO.
	•	COOK	588	511
FED. ROAD DIST. NO. 1 ILLINOIS FED. AID PROJECT				
62303 • (2021-922 PT2 ETC 2324.6-1P) R-11				

6/7/2006 1:32:03 PM P:\P40466\A\1\8 Cross 1B & 1B\SM\Cart 19\Cross Sections\1519_sloc_2021

ORIGINAL SURVEY	REVISIONS	BY	DATE
NOTE BOOK	PLOTTED		
NO.	TEMPLATE		
	AREAS CHECKED		
	AREAS CHECKED		

FINAL SURVEY	REVISIONS	BY	DATE
NOTE BOOK	PLOTTED		
NO.	TEMPLATE		
	AREAS CHECKED		
	AREAS CHECKED		

CTE | AECOM

15
10
5

SBLOC
3522+00.00

15
10
5



CUT=214 FILL=5 UNSUITABLES=7 EA EXC (SPL)=0 3522+00.00

15
10
5

SBLOC
3521+00.00

15
10
5



CUT=210 FILL=7 UNSUITABLES=3 EA EXC (SPL)=0 3521+00.00

15
10
5

SBLOC
3520+00.00

15
10
5

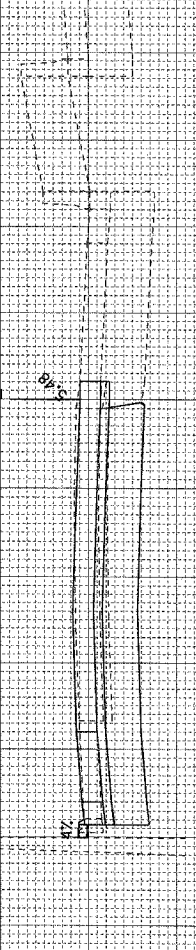

CUT=225 FILL=1 UNSUITABLES=0 EA EXC (SPL)=0 3520+00.00

20
15
10
5
0

SBLOC
3519+00.00

20
15
10
5
0

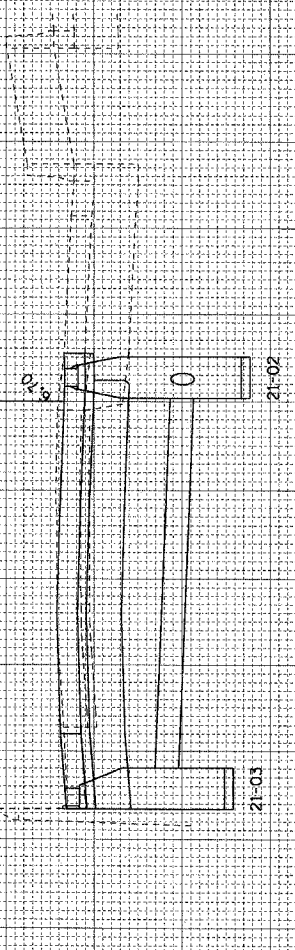

CUT=134 FILL=0 UNSUITABLES=0 EA EXC (SPL)=0 3519+00.00

20
15
10
5

SBLOC
3518+00.00

20
15
10
5

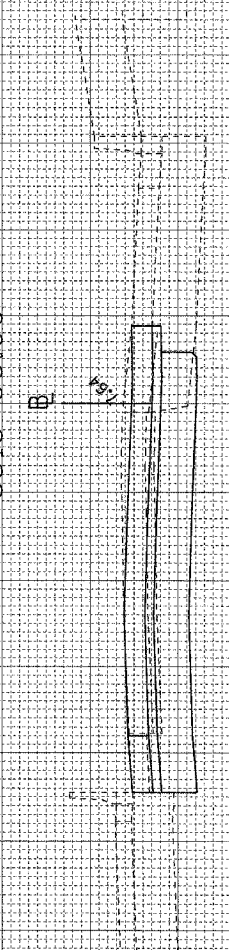

CUT=140 FILL=0 UNSUITABLES=0 EA EXC (SPL)=0 3518+00.00

F.A.T. RT.	SECTION	COUNTY	TOTAL SHEETS	SHEET NO.
90/94		COOK	588	512
FED. ROAD DIST. NO. 1 ILLINOIS FED. AID PROJECT				
62303 • (2021-922 PT2 ETC 2324.6-1P) R-11				

6/7/2006 1:32:06 PM P:\P40468\CH\WB-Ctrc B & 19-SP\Cont 19-Cross Sections\19_Sbloc_2.dwg

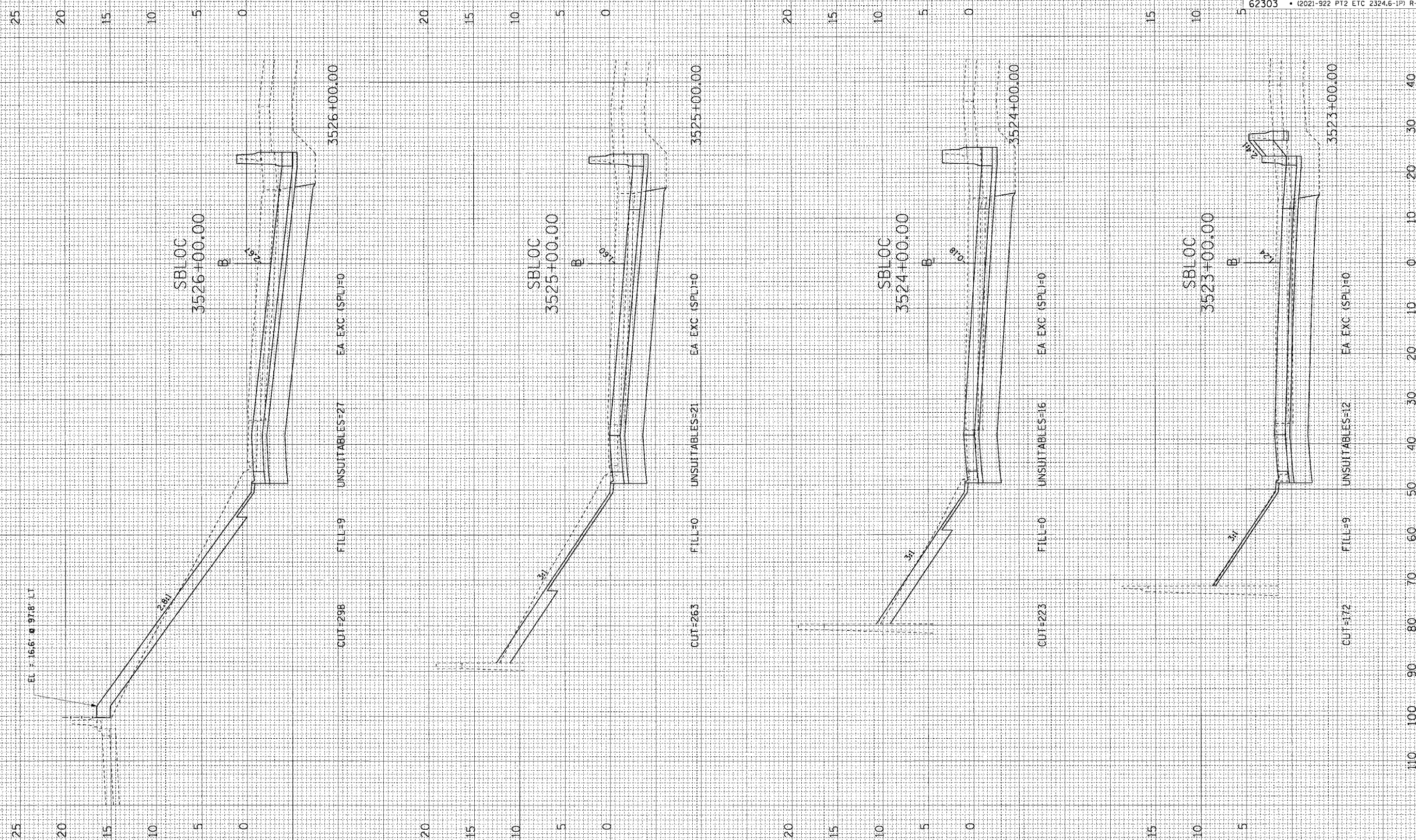

ORIGINAL SURVEY	SURVEYED	BY	DATE
PLOTTED	DATE		
NOTE BOOK	AREAS CHECKED		
NO.			

ORIGINAL SURVEY	SURVEYED	BY	DATE
PLOTTED	DATE		
NOTE BOOK	AREAS CHECKED		
NO.			

F.A.I. RTE.	SECTION	COUNTY	TOTAL SHEETS	SHEET NO.
90/94		COOK	588	513
FED. ROAD DIST. NO. 1 ILLINOIS FED. AID PROJECT				
62303 • (2021-922 PT2 ETC 2324.6-1P) R-11				

FINAL SURVEY	DATE
REVISIONS	BY
NO.	

ORIGINAL SURVEY	DATE
REVISIONS	BY
NO.	

CTE | AECOM

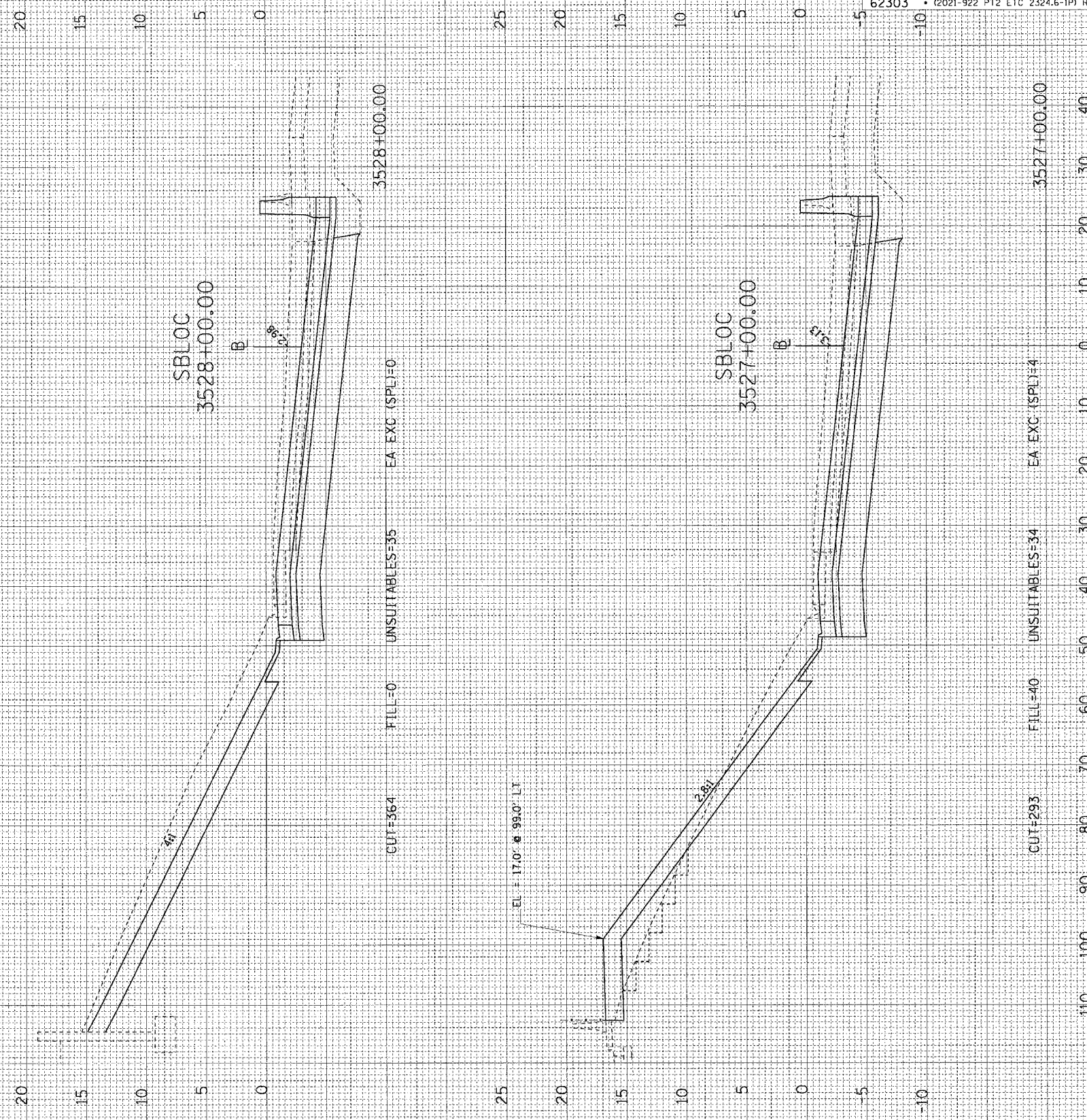

F.A.I. RTE.	SECTION	COUNTY	TOTAL SHEETS	SHEET NO.
90/94		COOK	588	514
FED. ROAD DIST. NO. 1 ILLINOIS FED. AID PROJECT				
62303 • (2021-922 PT2 ETC 2324.6-1P) R-11				

6/23/2006 9:55:10 AM F:\P\0466\CV\18-Cntrs\18 & 19\S\PC\18 15Cross Sections\18_SbLoc_2.dwg

FINAL SURVEY SURVEYED, PLOTTED, NOTE BOOK, TEMPLATE, AREAS CHECKED, BY, DATE

ORIGINAL SURVEY SURVEYED, PLOTTED, NOTE BOOK, TEMPLATE, AREAS CHECKED, BY, DATE

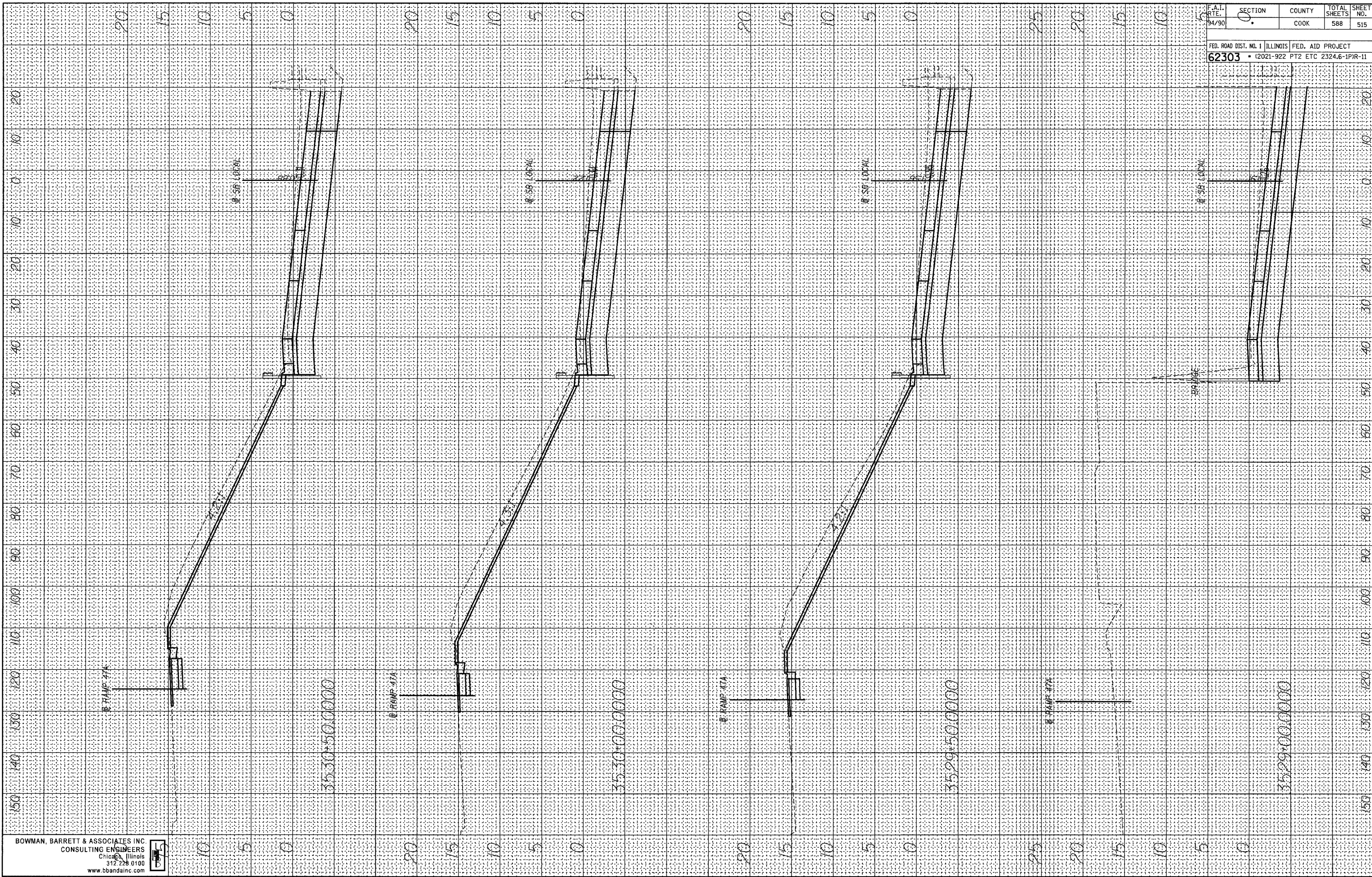

BOWMAN, BARRETT & ASSOCIATES INC.
CONSULTING ENGINEERS
Chicago, Illinois
312.228.0100
www.bbainc.com



F.A.I. RTE. 94/90	SECTION 0	COUNTY COOK	TOTAL SHEETS 588	SHEET NO. 515
FED. ROAD DIST. NO. 1 ILLINOIS FED. AID PROJECT				
62303 • (2021-922 PT2 ETC 2324.6-1)PR-11				

6/8/2006 2:44:06 PM n:\660\card\civil\19\shred\660_9cxs01.dgn

FINAL SURVEY SURVEYED PLOTTED DATE
 NOTE BOOK TEMPLATE BY
 AREAS CHECKED

ORIGINAL SURVEY SURVEYED PLOTTED DATE
 NOTE BOOK TEMPLATE BY
 AREAS CHECKED

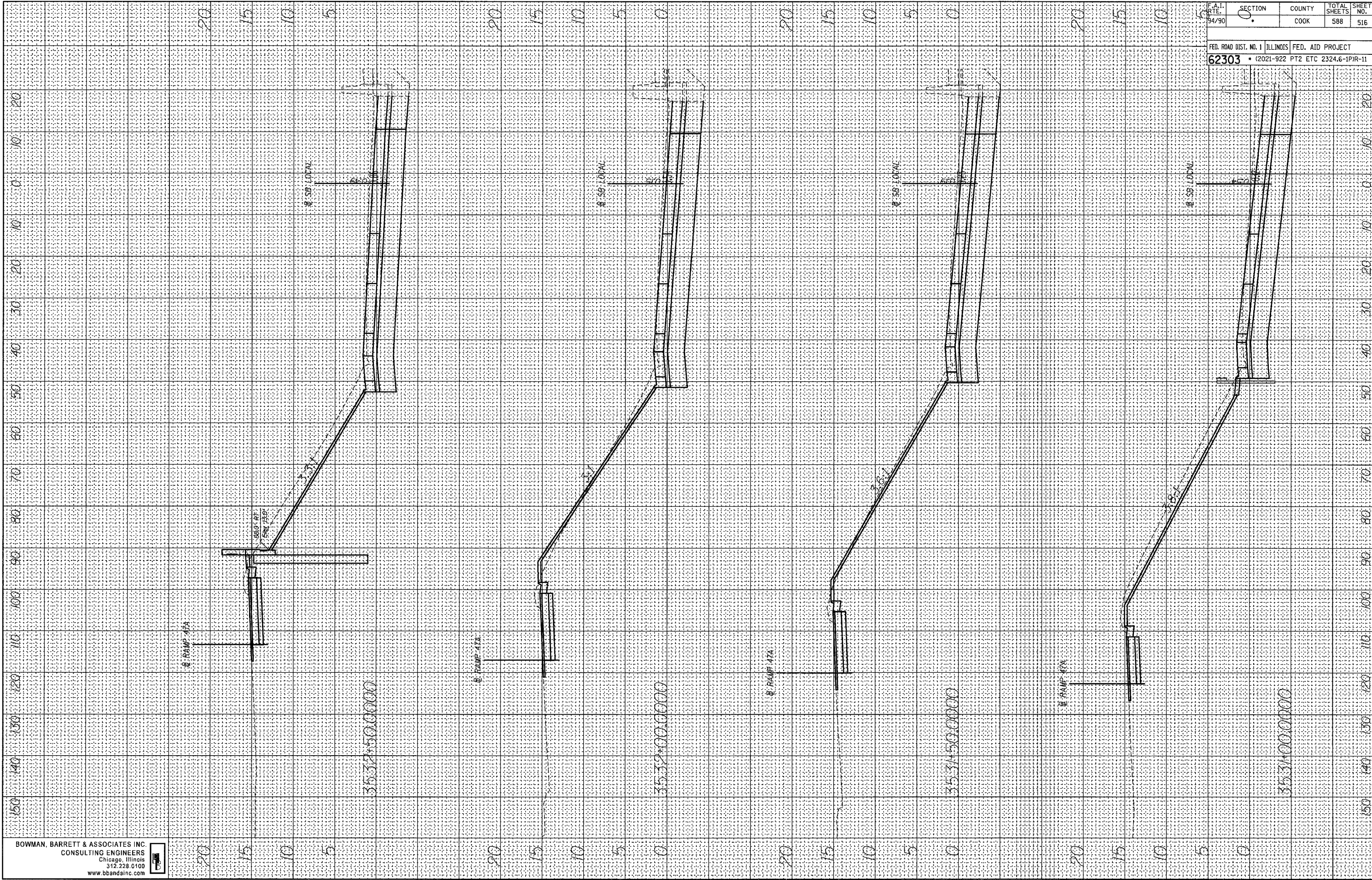

F.A.I. RITE. 94/90	SECTION 0	COUNTY COOK	TOTAL SHEETS 588	SHEET NO. 516
FED. ROAD DIST. NO. 1		ILLINOIS		FED. AID PROJECT
62303		(2021-922 PT2 ETC		2324.6-1PR-11

BOWMAN, BARRETT & ASSOCIATES INC.
 CONSULTING ENGINEERS
 Chicago, Illinois
 312.228.6100
 www.bbadainc.com

6/8/2006 2:44:07 PM n:\660\card\CATV\DW\Sheet 516.dwg

FINAL SURVEY SURVEYED BY DATE
 PLOTTED TEMPLATE
 NOTE BOOK NO.
 AREAS CHECKED

ORIGINAL SURVEY SURVEYED BY DATE
 PLOTTED TEMPLATE
 NOTE BOOK NO.
 AREAS CHECKED

F.A.I. RTE. 94/90	SECTION 0	COUNTY COOK	TOTAL SHEETS 588	SHEET NO. 517
FED. ROAD DIST. NO. 1 ILLINOIS		FED. AID PROJECT		
62303		(2021-922 PT2 ETC 2324.6-1PIR-11		

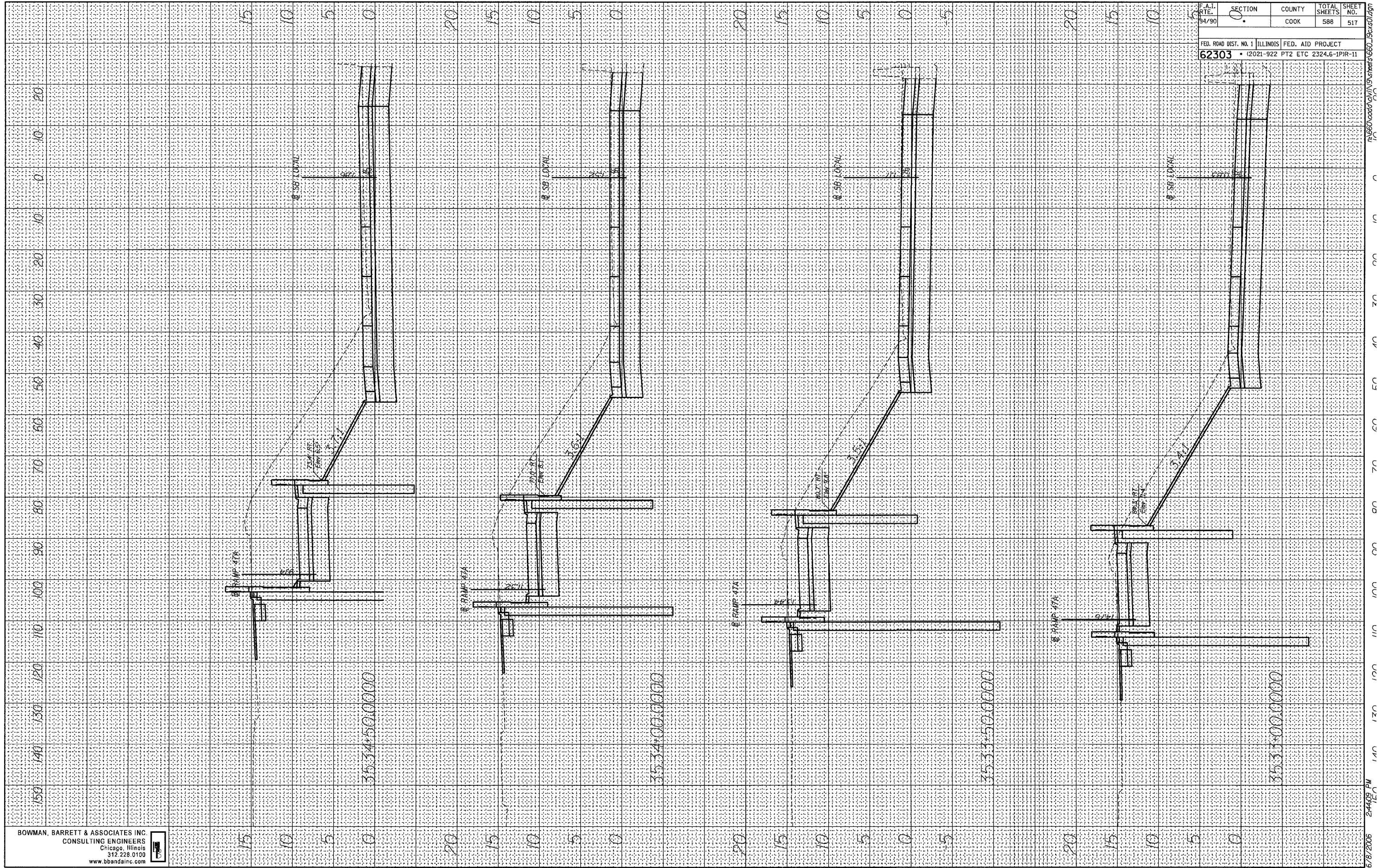

BOWMAN, BARRETT & ASSOCIATES INC.
 CONSULTING ENGINEERS
 Chicago, Illinois
 312-228-0100
 www.bbainc.com

6/8/2006 2:44:09 PM
 17:\650\ccdd\civ\1\9\stree5\660_9c\st01.dgn

FINAL SURVEY BY DATE
 SURVEYED BY
 NOTE BOOK NO.
 TEMPLATES AREAS CHECKED

ORIGINAL SURVEY BY DATE
 SURVEYED BY
 NOTE BOOK NO.
 TEMPLATES AREAS CHECKED

F.A.I. RTE. 34/90	SECTION 0	COUNTY COOK	TOTAL SHEETS 588	SHEET NO. 518
FED. ROAD DIST. NO. 1 ILLINOIS FED. AID PROJECT				
62303 • (2021-922 PT2 ETC 2324.6-1PIR-11				

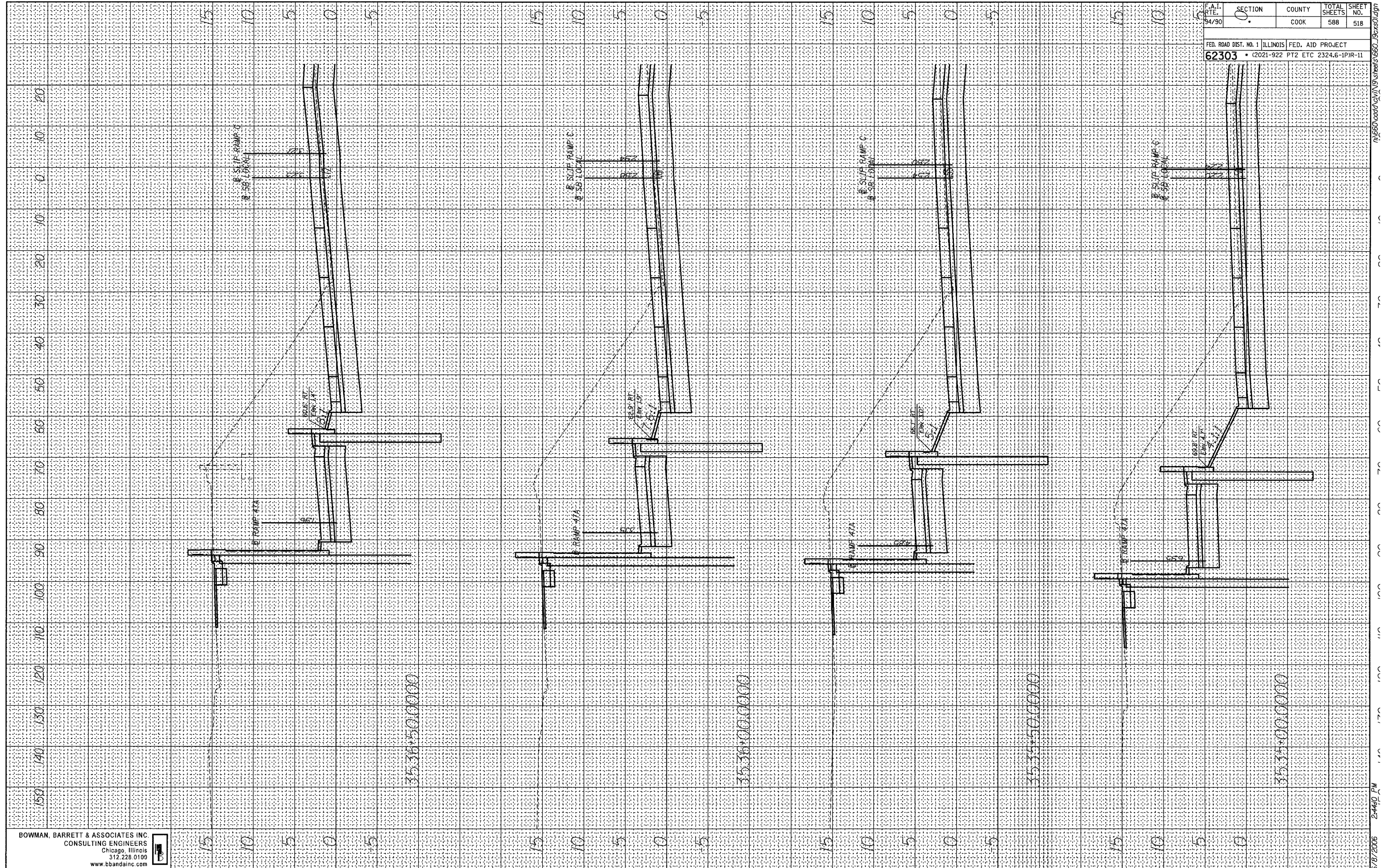

BOWMAN, BARRETT & ASSOCIATES INC
 CONSULTING ENGINEERS
 Chicago, Illinois
 312.228.0100
 www.bbainc.com



6/8/2008 2:44:00 PM

FINAL SURVEY NO. _____
 SUBMITTED _____
 PLOTTED _____
 TEMPLATE _____
 NOTE BOOK _____
 AREAS CHECKED _____
 BY _____ DATE _____

ORIGINAL SURVEY NO. _____
 SUBMITTED _____
 PLOTTED _____
 TEMPLATE _____
 NOTE BOOK _____
 AREAS CHECKED _____
 BY _____ DATE _____

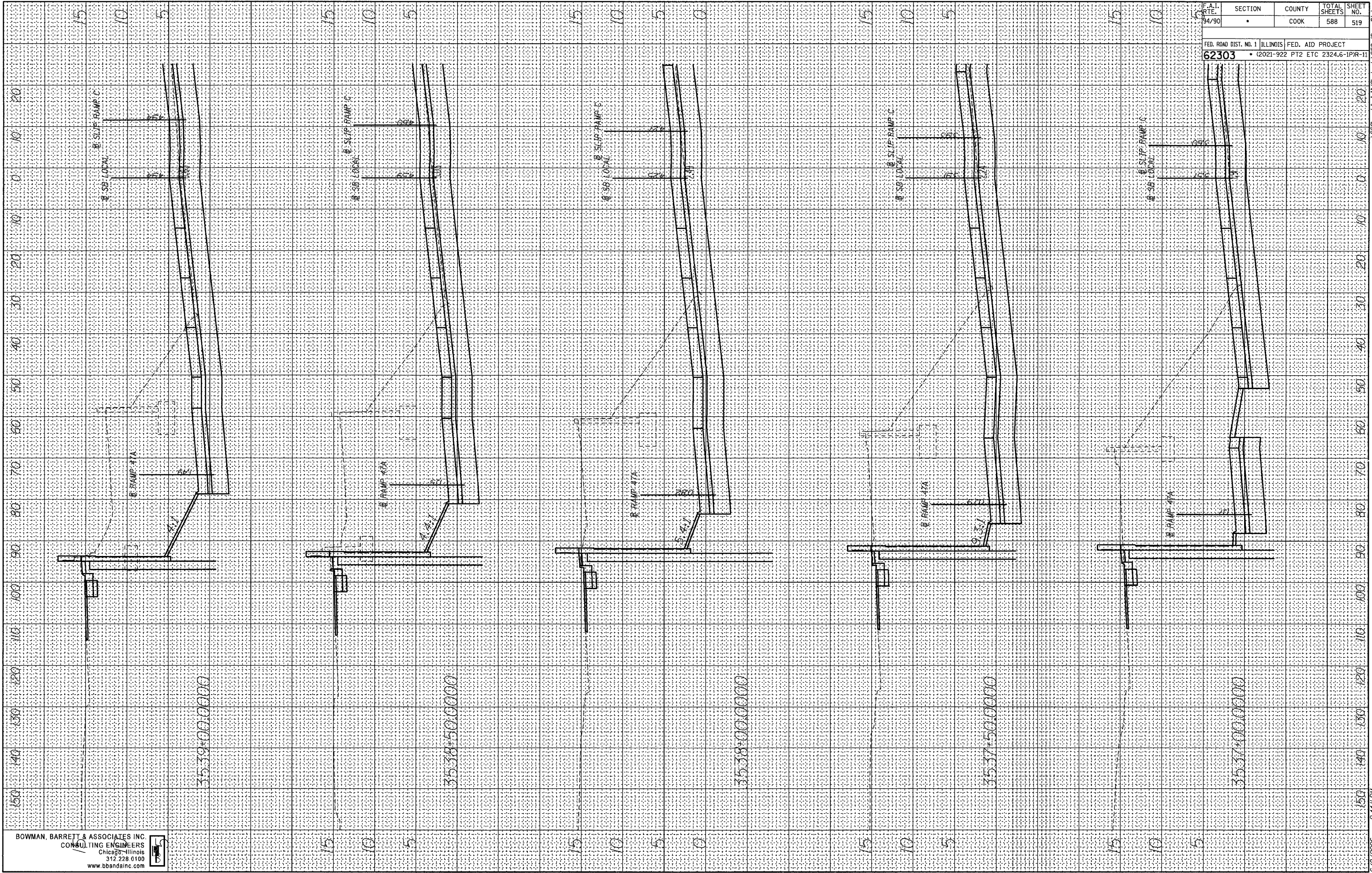

F.A.I. RTE. 94/90	SECTION *	COUNTY COOK	TOTAL SHEETS 588	SHEET NO. 519
FED. ROAD DIST. NO. 1		ILLINOIS	FED. AID PROJECT	
62303		* (2021-922 PT2 ETC 2324.6-1PR-11)		



FINAL SURVEY SURVEYED PLOTTED DATE
 NOTE BOOK TEMPLATE BY
 NO. AREAS CHECKED

ORIGINAL SURVEY SURVEYED PLOTTED DATE
 NOTE BOOK TEMPLATE BY
 NO. AREAS CHECKED

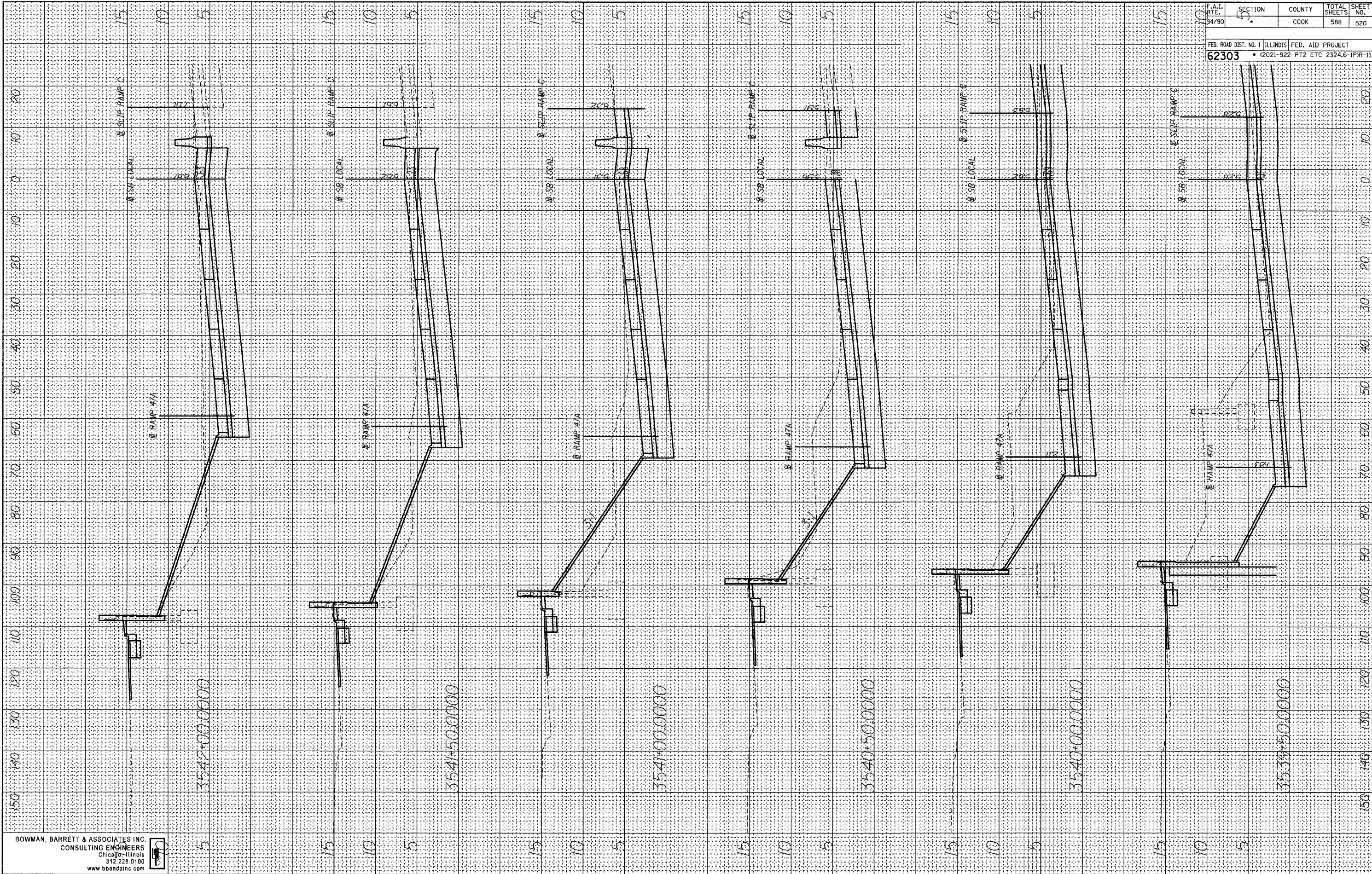

BOWMAN, BARRETT & ASSOCIATES INC.
 CONSULTING ENGINEERS
 CHICAGO, ILLINOIS
 312.228.0100
 www.bbandainc.com



F.A.T. RTE. 94/90	SECTION 4	COUNTY COOK	TOTAL SHEETS 588	SHEET NO. 520
FED. ROAD DIST. NO. 1 ILLINOIS FED. AID PROJECT				
62303 (2021-922 PT2 ETC 2324.6-IPR-11)				

6/8/2006 2:44:22 PM n:\660\ccard\CH\IN\Streets\660_94x501.dgn

FINAL SURVEY
 SURVEYED
 PLOTTED
 NOTE BOOK
 TEMPLATE
 AREAS CHECKED
 NO.

ORIGINAL SURVEY
 SURVEYED
 PLOTTED
 NOTE BOOK
 TEMPLATE
 AREAS CHECKED
 NO.

BY _____ DATE _____

BY _____ DATE _____

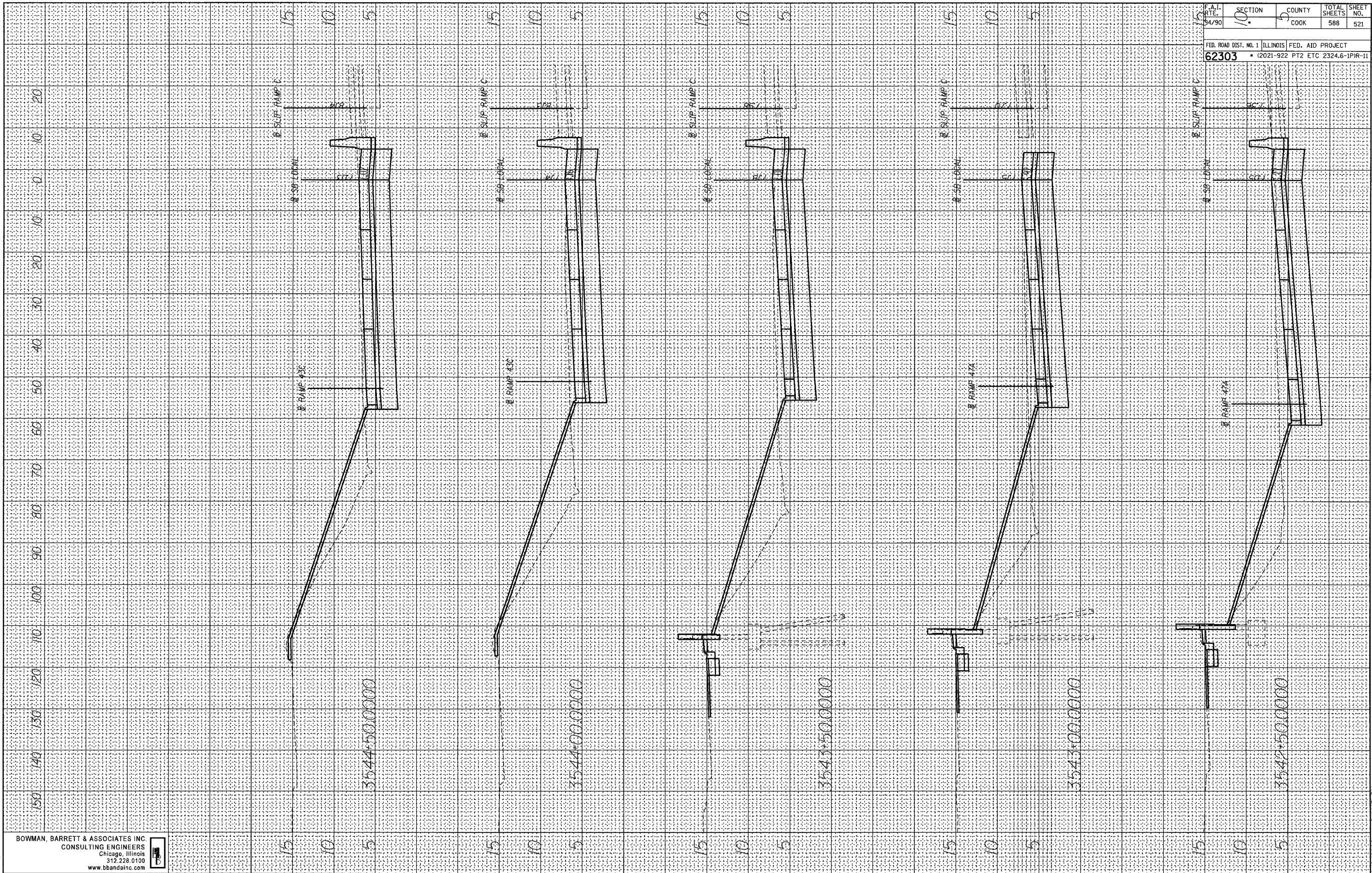

BOWMAN, BARRETT & ASSOCIATES INC.
 CONSULTING ENGINEERS
 Chicago Illinois
 312.228.0100
 www.bbainc.com



F.A.I. RTE. 94/90	SECTION 10	COUNTY COOK	TOTAL SHEETS 588	SHEET NO. 521
FED. ROAD DIST. NO. 1 ILLINOIS		FED. AID PROJECT		
62303		(2021-922 PT2 ETC 2324.6-1PIR-11)		

6/8/2006 2:44:13 PM 7:\660\ccard\cay\219\chairs\6602_19cxs01.dgn

FINAL SURVEY PLOTTED
 NOTE BOOK NO. _____
 BY _____ DATE _____
 SURVEYED _____
 PLOTTED _____
 TEMPLATE AREAS CHECKED _____

ORIGINAL SURVEY PLOTTED
 NOTE BOOK NO. _____
 BY _____ DATE _____
 SURVEYED _____
 PLOTTED _____
 TEMPLATE AREAS CHECKED _____

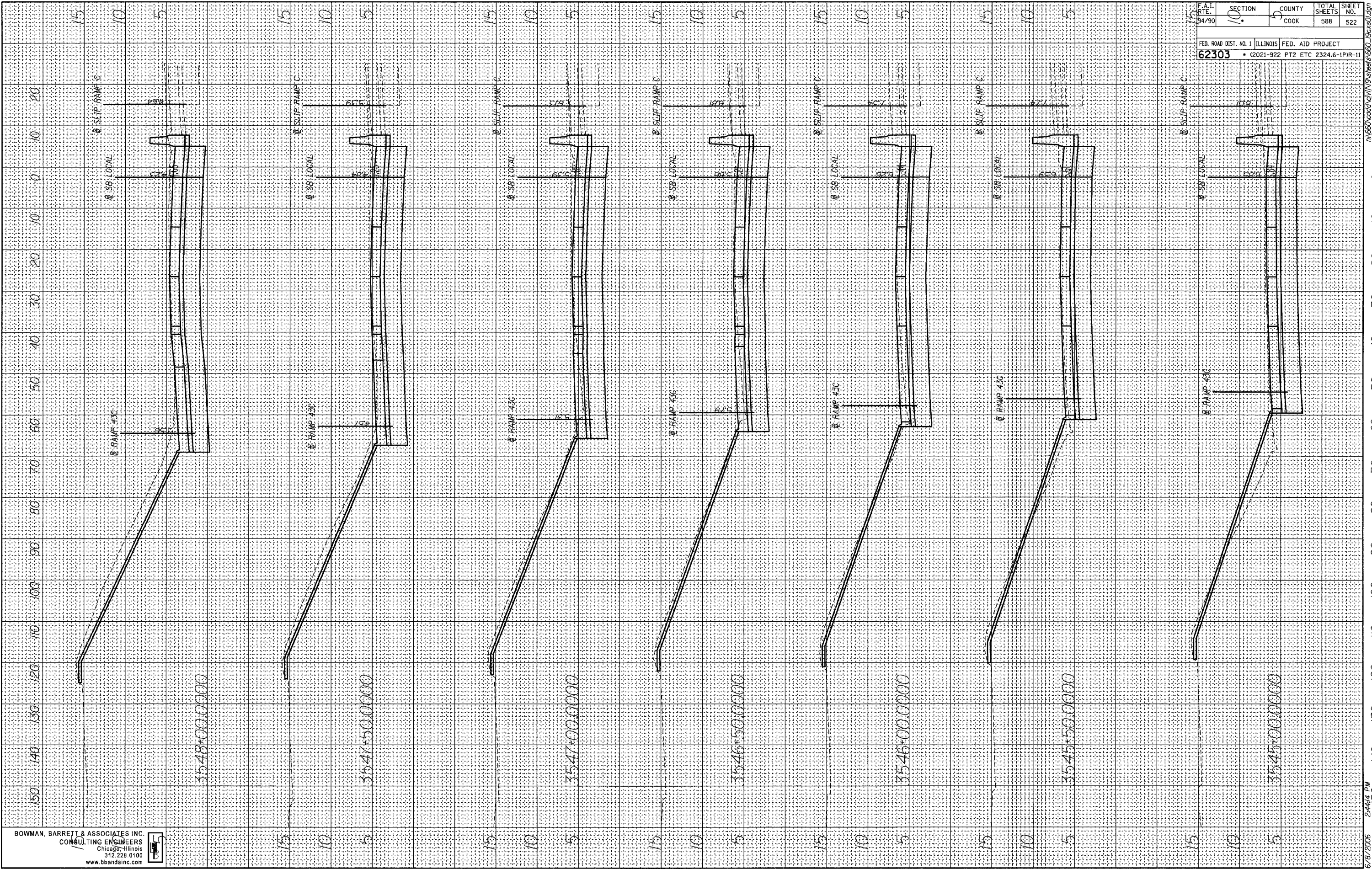

BOWMAN, BARRETT & ASSOCIATES INC
 CONSULTING ENGINEERS
 Chicago - Illinois
 312.228.0100
 www.bbandainc.com



F.A.I. RATE 04/90	SECTION 10	COUNTY COOK	TOTAL SHEETS 588	SHEET NO. 522
FED. ROAD DIST. NO. 1 62303		ILLINOIS FED. AID PROJECT PT2 ETC 2324.6-1PIR-11		

6/8/2006 2:44:44 PM 150 140 130 120 110 100 90 80 70 60 50 40 30 20 10 0 15 10 5

FINAL SURVEY SURVEYED BY DATE
 PLOTTED TEMPLATE
 NOTE BOOK NO. AREAS CHECKED

ORIGINAL SURVEY SURVEYED BY DATE
 PLOTTED TEMPLATE
 NOTE BOOK NO. AREAS CHECKED

BOWMAN, BARRETT & ASSOCIATES INC.
 CONSULTING ENGINEERS
 Chicago, Illinois
 312.228.0100
 www.bbandainc.com

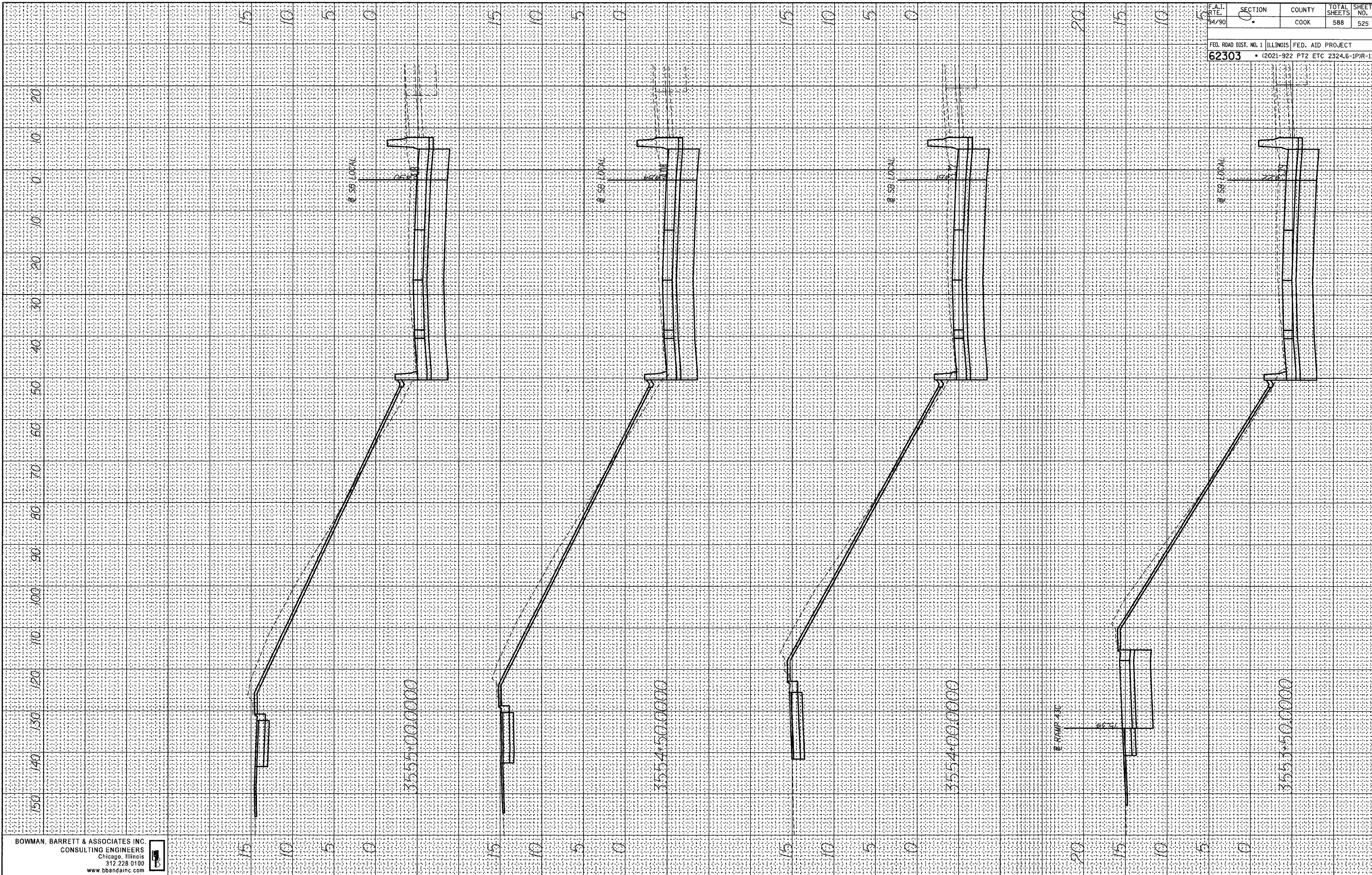

F.A.I. RTE. 94/90	SECTION 0	COUNTY COOK	TOTAL SHEETS 588	SHEET NO. 525
FED. ROAD DIST. NO. 1		ILLINOIS	FED. AID PROJECT	
62303		• (2021-922 PT2 ETC 2324.6-1PIR-11		

6/8/2006 2:44:08 PM 150 120 110 100 90 80 70 60 50 40 30 20 10 0 10 20 30 40 50 60 70 80 90 100 110 120 130 140 150

FINAL SURVEY
 SURVEYED BY _____ DATE _____
 PLOTTED BY _____
 NOTE BOOK NO. _____
 AREAS CHECKED _____

ORIGINAL SURVEY
 SURVEYED BY _____ DATE _____
 PLOTTED BY _____
 NOTE BOOK NO. _____
 AREAS CHECKED _____

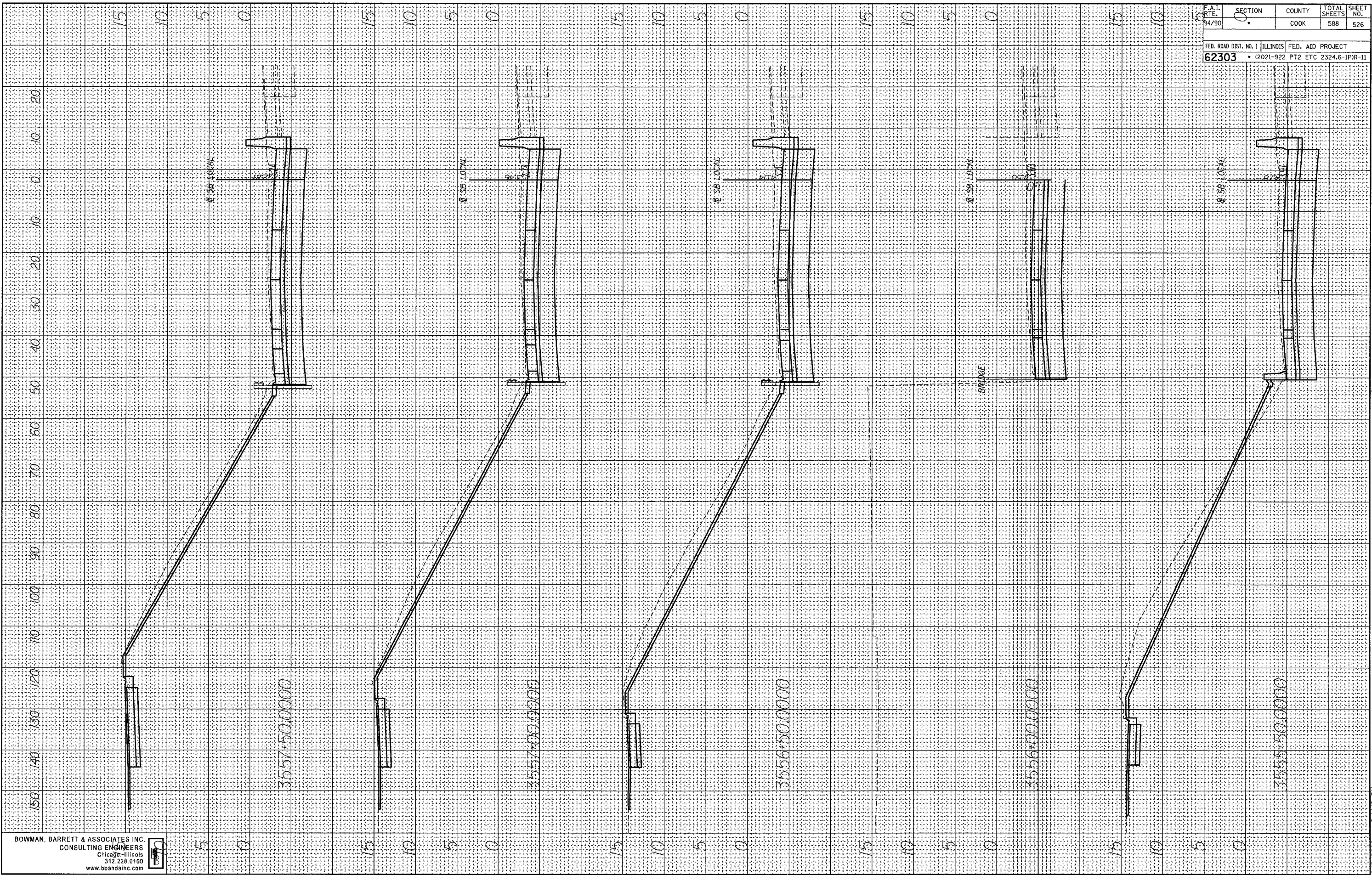

BOWMAN, BARRETT & ASSOCIATES INC
 CONSULTING ENGINEERS
 Chicago - Illinois
 312.228.0100
 www.bbainc.com



F.A.I. R.T.E. 84/90	SECTION 0	COUNTY COOK	TOTAL SHEETS 588	SHEET NO. 526
FED. ROAD DIST. NO. 1		ILLINOIS		FED. AID PROJECT
62303		(2021-922 PT2 ETC		2324.6-1P1R-11

6/8/2006 2:44:19 PM

FINAL SURVEY NO.	SURVEYED	BY	DATE
NOTE BOOK NO.	PLOTTED		
AREAS CHECKED	TEMPLATE		

ORIGINAL SURVEY NO.	SURVEYED	BY	DATE
NOTE BOOK NO.	PLOTTED		
AREAS CHECKED	TEMPLATE		

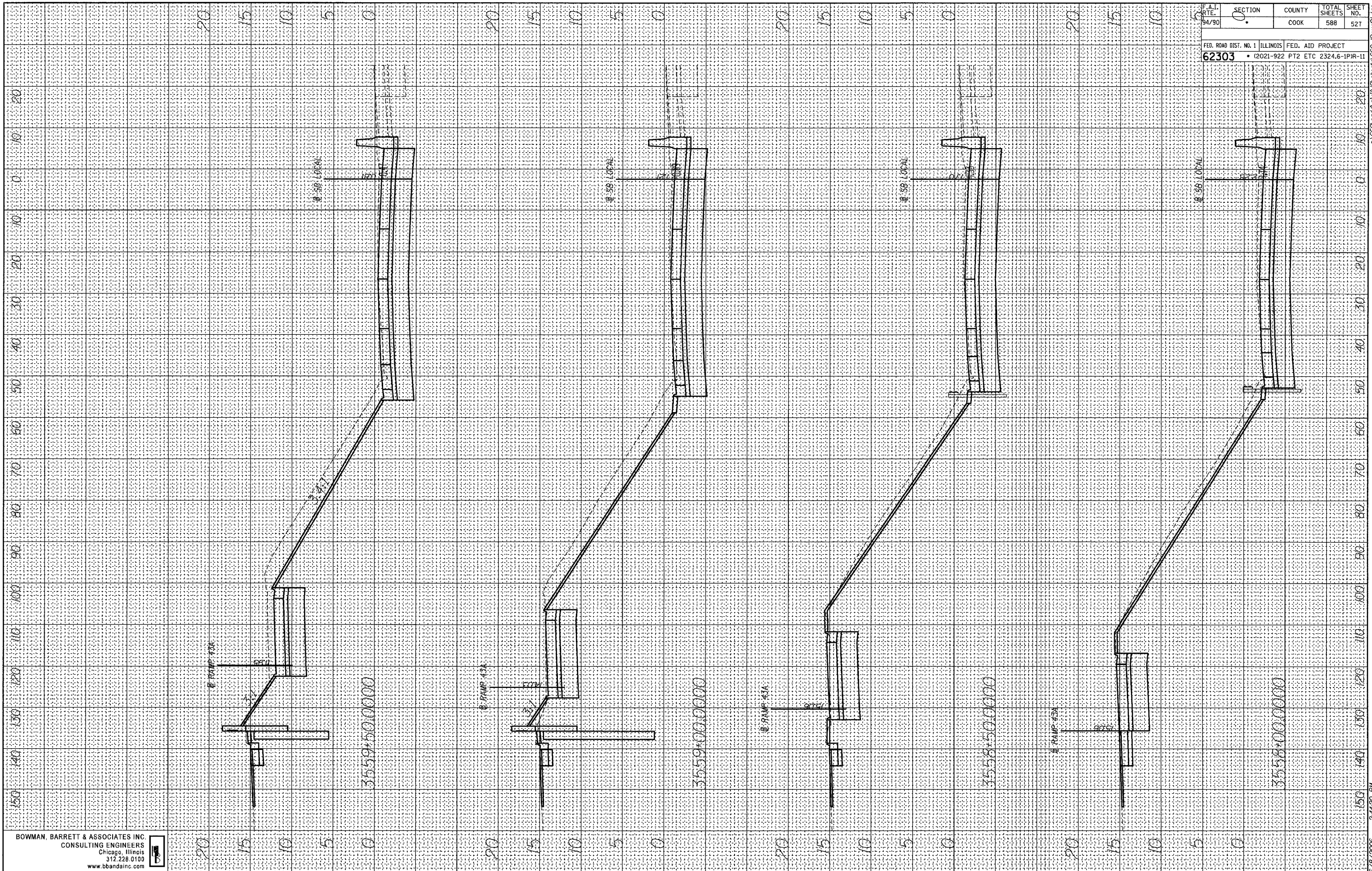

BOWMAN, BARRETT & ASSOCIATES INC.
CONSULTING ENGINEERS
Chicago, Illinois
312.228.0100
www.bbandainc.com

F.A.I. DIST. NO. 1	SECTION	COUNTY	TOTAL SHEETS	SHEET NO.
62303	0	COOK	588	527
FED. ROAD DIST. NO. 1 ILLINOIS		FED. AID PROJECT		
62303		2021-922 PT2 ETC 2324.6-IPR-11		

FINAL SURVEY DATE
 SURVEY PLOTTED BY
 NOTE BOOK NO. DATE
 AREAS CHECKED

ORIGINAL SURVEY DATE
 SURVEY PLOTTED BY
 NOTE BOOK NO. DATE
 AREAS CHECKED

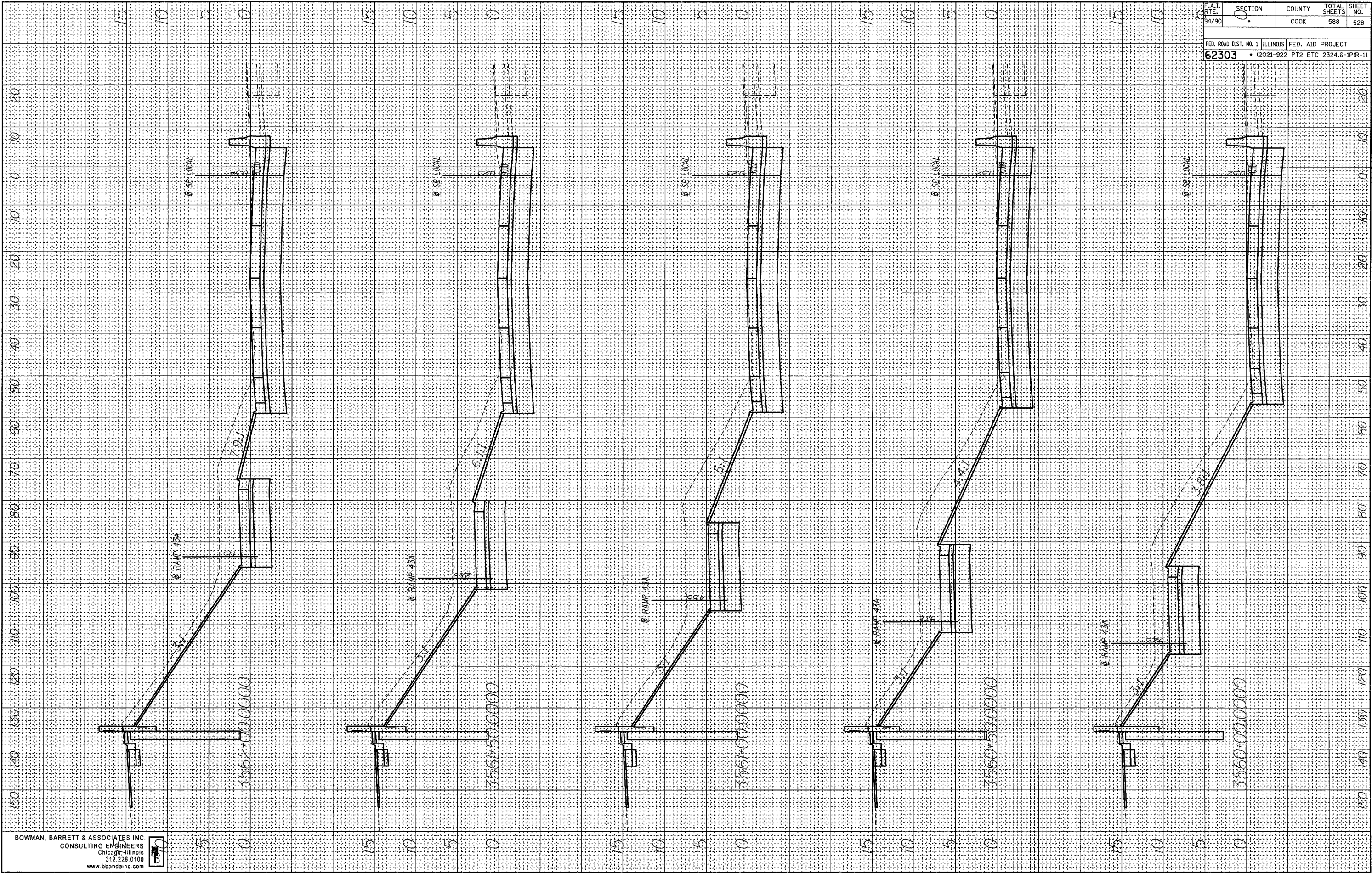

BOWMAN, BARRETT & ASSOCIATES INC.
 CONSULTING ENGINEERS
 Chicago - Illinois
 312.238.0100
 www.bbandainc.com

F.A.I. R.T.E.	SECTION	COUNTY	TOTAL SHEETS	SHEET NO.
64/90	0	COOK	588	528
FED. ROAD DIST. NO. 1 ILLINOIS		FED. AID PROJECT		
62303		PT2 ETC 2324.6-1PR-11		

6/8/2006 2:44:21 PM T:\660\cadd\CIVIL\Sheet5\660_19cxs01.dgn

FINAL SURVEY BY DATE
 SURVEYED BY
 PLOTTED BY
 NOTE BOOK NO.
 DATE
 AREAS CHECKED

ORIGINAL SURVEY BY DATE
 SURVEYED BY
 PLOTTED BY
 NOTE BOOK NO.
 DATE
 AREAS CHECKED

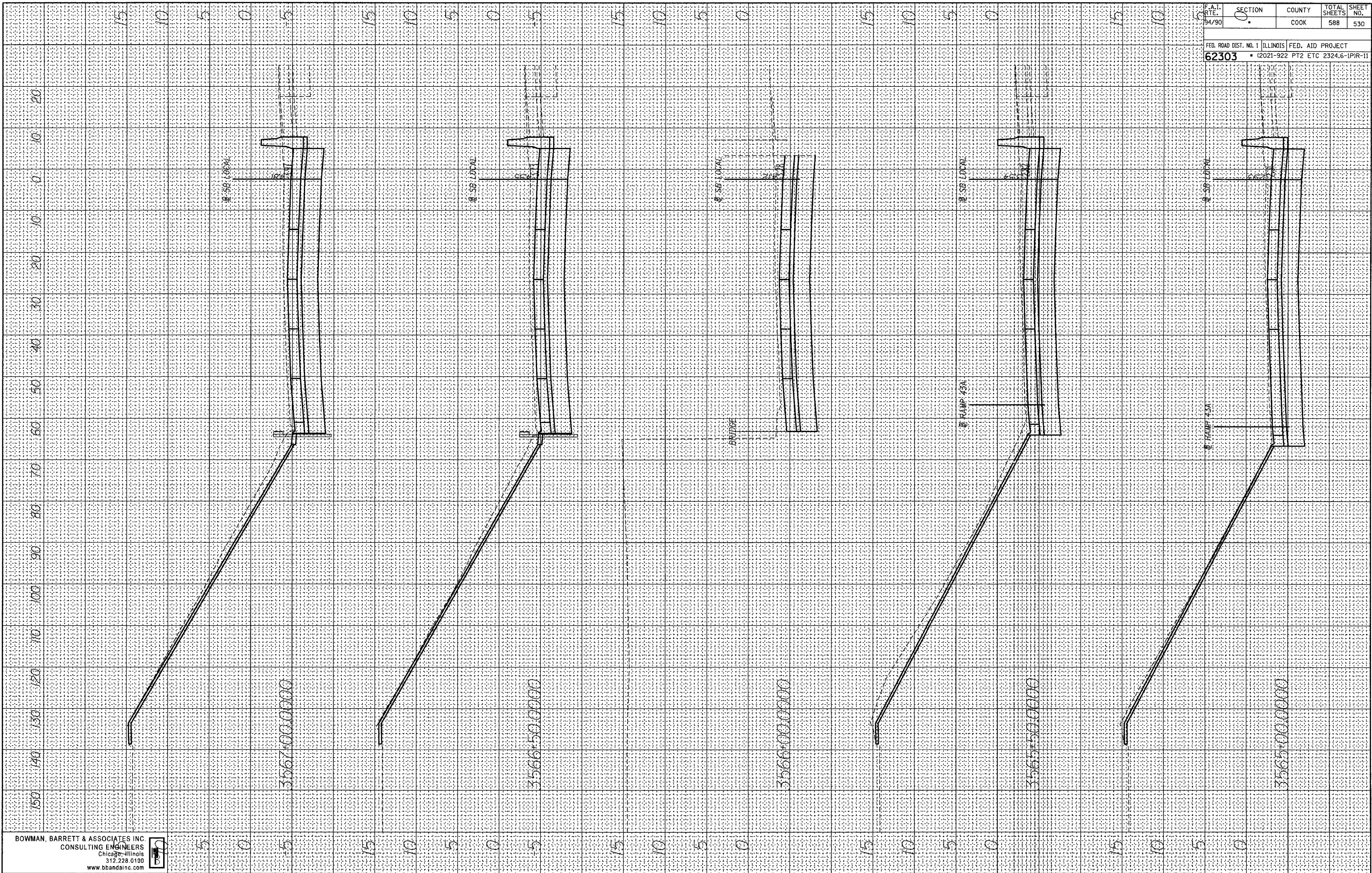

BOWMAN, BARRETT & ASSOCIATES INC.
 CONSULTING ENGINEERS
 Chicago - Illinois
 312.238.6100
 www.bbandainc.com

F.A.I. RTE. 94/90	SECTION 0	COUNTY COOK	TOTAL SHEETS 588	SHEET NO. 530
FED. ROAD DIST. NO. 1 ILLINOIS FED. AID PROJECT				
62303 • (2021-922 PT2 ETC 2324.6-IPR-11)				

6/8/2006 2:44:23 PM 150

FINAL SURVEY	SURVEYED	BY	DATE
NOTE BOOK NO.	PLOTTED		
	DATE		
	AREAS CHECKED		

ORIGINAL SURVEY	SURVEYED	BY	DATE
NOTE BOOK NO.	PLOTTED		
	DATE		
	AREAS CHECKED		

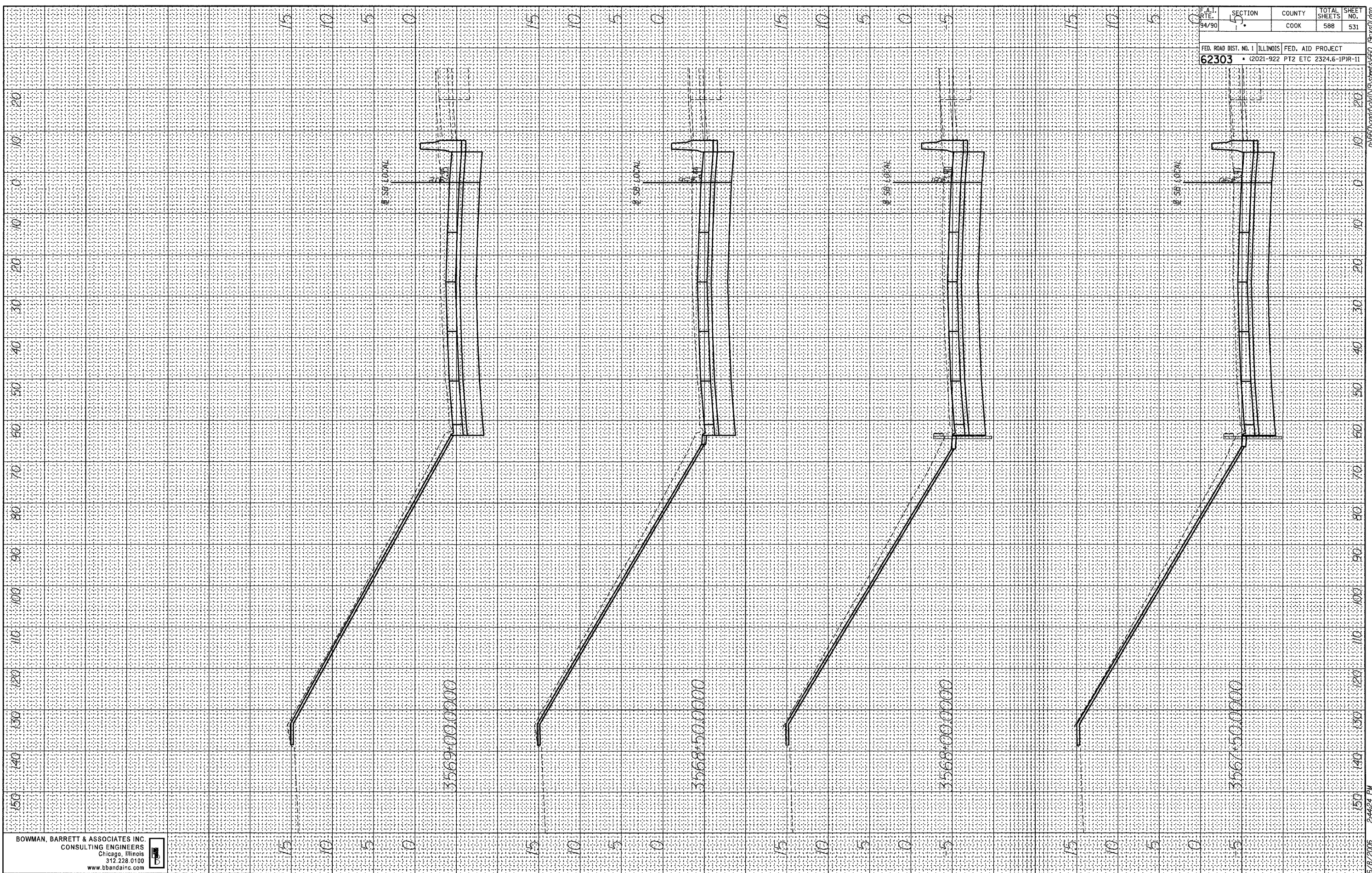

BOWMAN, BARRETT & ASSOCIATES INC.
 CONSULTING ENGINEERS
 Chicago, Illinois
 312.228.0100
 www.bbandainc.com

F.A.I. RTE. 94/90	SECTION 5	COUNTY COOK	TOTAL SHEETS 588	SHEET NO. 531
FED. ROAD DIST. NO. 1		ILLINOIS		FED. AID PROJECT
62303		2021-922		PT2 ETC 2324.6-1PR-11

6/8/2006 2:44:24 PM

FINAL SURVEY	SURVEYED	BY	DATE
NOTE BOOK NO.	PLOTTED		
	TEMPLATE		
	AREAS CHECKED		

ORIGINAL SURVEY	SURVEYED	BY	DATE
NOTE BOOK NO.	PLOTTED		
	TEMPLATE		
	AREAS CHECKED		

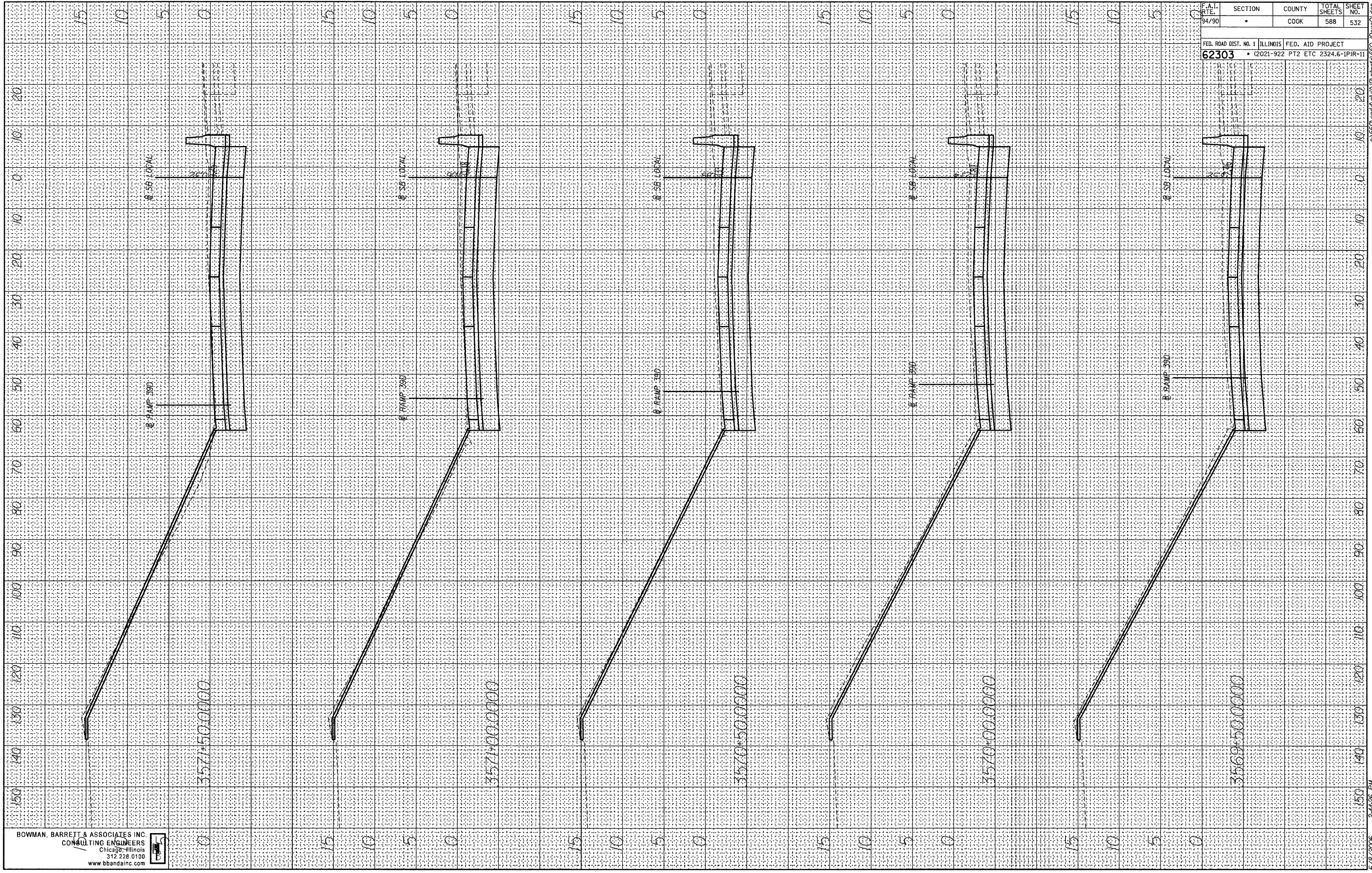

BOWMAN, BARRETT & ASSOCIATES INC.
CONSULTING ENGINEERS
Chicago, Illinois
312.228.0100
www.bbainc.com



F.A.I. RITE.	SECTION	COUNTY	TOTAL SHEETS	SHEET NO.
94/90	.	COOK	588	532
FED. ROAD DIST. NO. 1		ILLINOIS	FED. AID PROJECT	
62303		(2021-922 PT2 ETC	2324.6-IPR-11	

6/8/2006 2:44:26 PM r:\660\road\civ\19\chefs\660_09\as01.dgn

FINAL SURVEY
 SURVEYED _____
 PLOTTED _____
 NOTE BOOK NO. _____
 DATE _____
 AREAS CHECKED _____

ORIGINAL SURVEY
 SURVEYED _____
 PLOTTED _____
 NOTE BOOK NO. _____
 DATE _____
 AREAS CHECKED _____

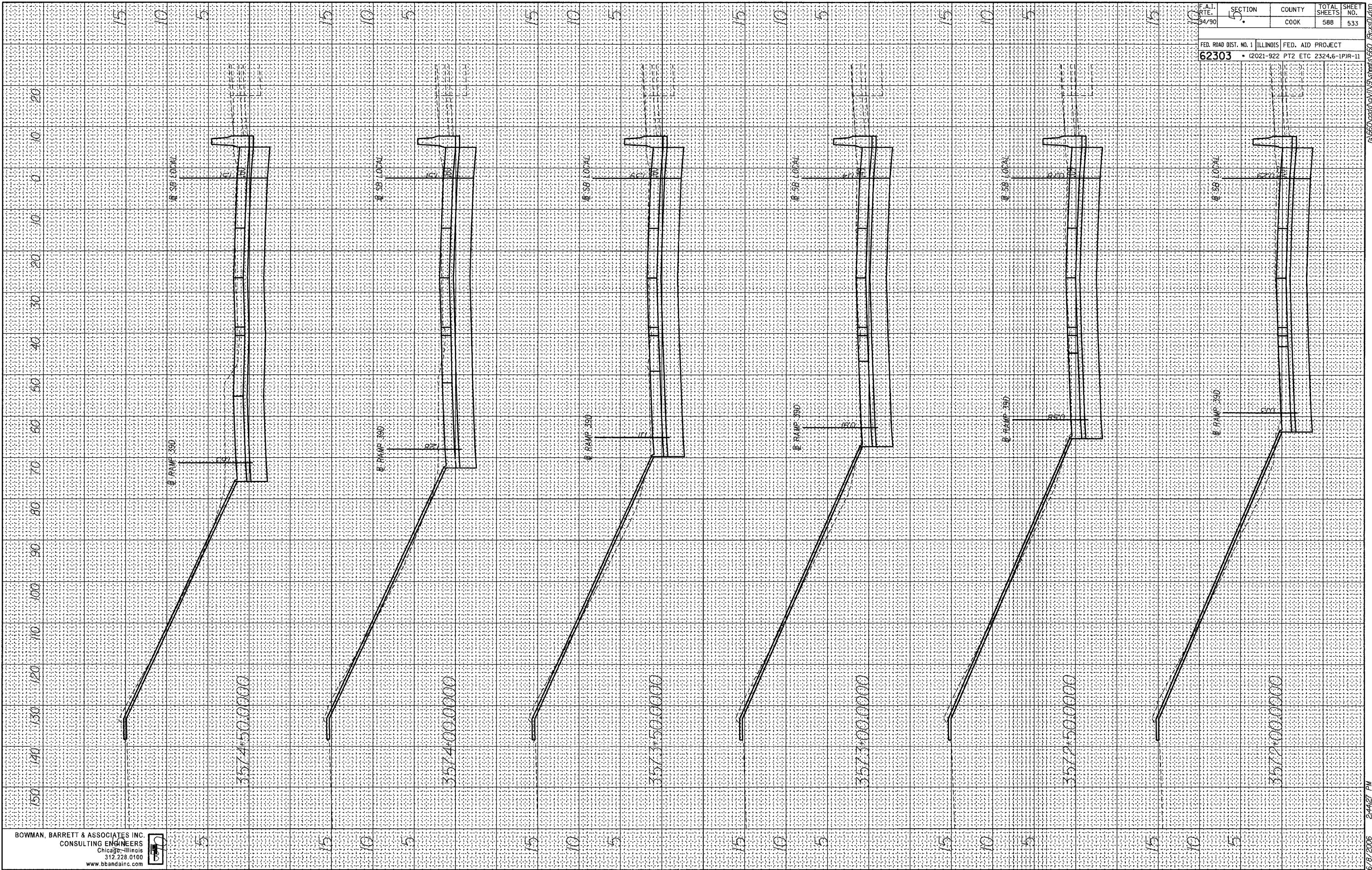

BOWMAN, BARRETT & ASSOCIATES INC.
 CONSULTING ENGINEERS
 Chicago - Illinois
 312.238.0100
 www.bbandainc.com



F.A.I. R.T.E.	SECTION	COUNTY	TOTAL SHEETS	SHEET NO.
94/90	5	COOK	588	533
FED. ROAD DIST. NO. 1		ILLINOIS		FED. AID PROJECT
62303		(2021-922 PT2 ETC 2324.6-1PIR-11		

6/8/2006 2:44:27 PM 150 140 130 120 110 100 90 80 70 60 50 40 30 20 10 0 5 10 15

FINAL SURVEY BY DATE
 SURVEYED PLOTTED
 NOTE BOOK NO. DATE
 AREAS CHECKED

ORIGINAL SURVEY BY DATE
 SURVEYED PLOTTED
 NOTE BOOK NO. DATE
 AREAS CHECKED

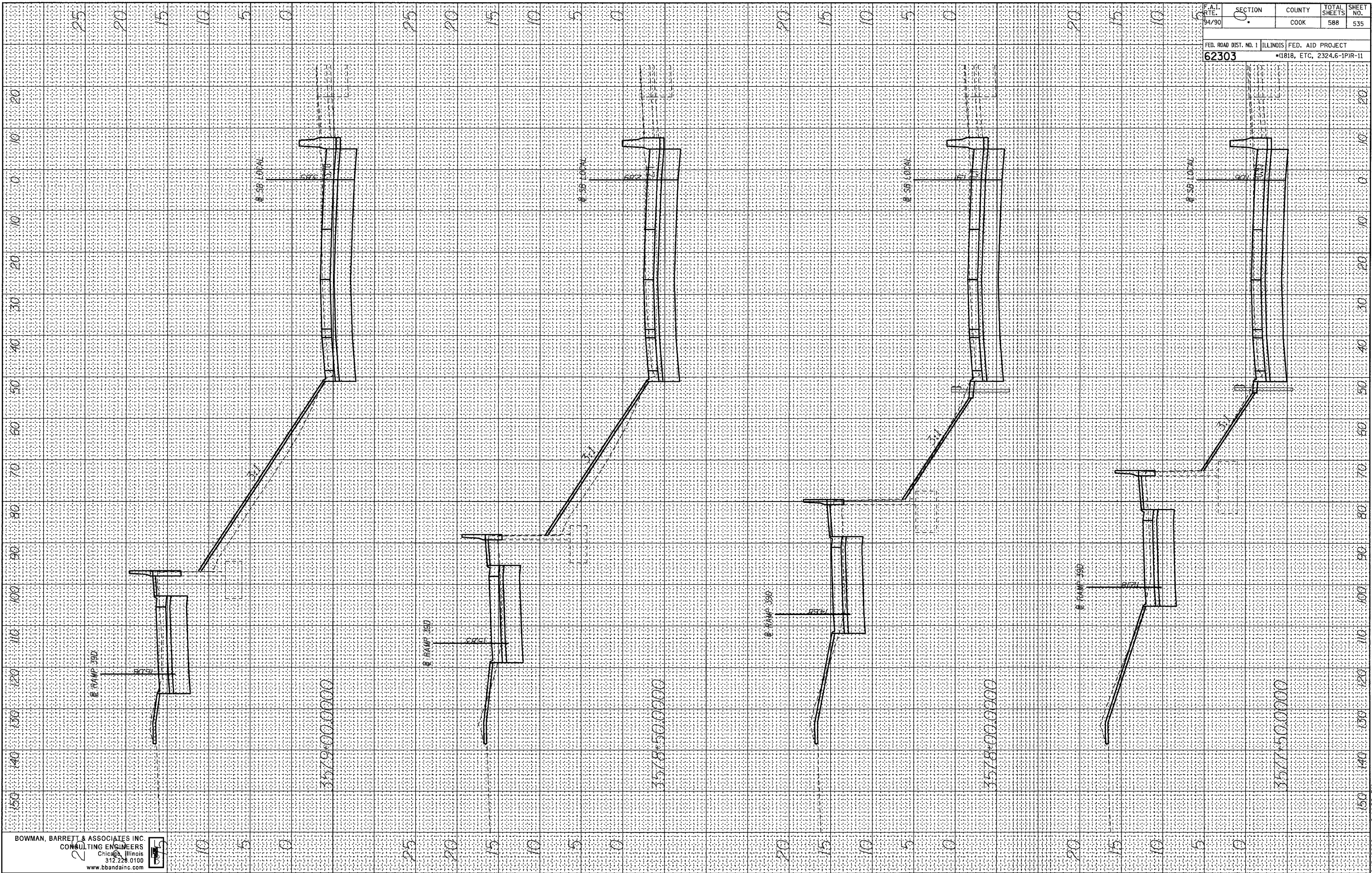

BOWMAN, BARRETT & ASSOCIATES INC.
 CONSULTING ENGINEERS
 CHICAGO, ILLINOIS
 312.228.0100
 www.bbandainc.com



F.A.I. R.T.E. 94/90	SECTION 0	COUNTY COOK	TOTAL SHEETS 588	SHEET NO. 535
FED. ROAD DIST. NO. 1		ILLINOIS FED. AID PROJECT		
62303		*1818, ETC, 2324.6-1P/R-11		

6/8/2006 2:44:29 PM
 R:\660\acad\CIVIL\9\Sheet's\660_19x3501.dgn

FINAL SURVEY SURVEYED SURVEYED SURVEYED SURVEYED
 NO. BOOK PLOTTED PLOTTED PLOTTED PLOTTED
 NO. AREAS CHECKED AREAS CHECKED AREAS CHECKED AREAS CHECKED
 BY DATE

ORIGINAL SURVEY SURVEYED SURVEYED SURVEYED SURVEYED
 NO. BOOK PLOTTED PLOTTED PLOTTED PLOTTED
 NO. AREAS CHECKED AREAS CHECKED AREAS CHECKED AREAS CHECKED
 BY DATE

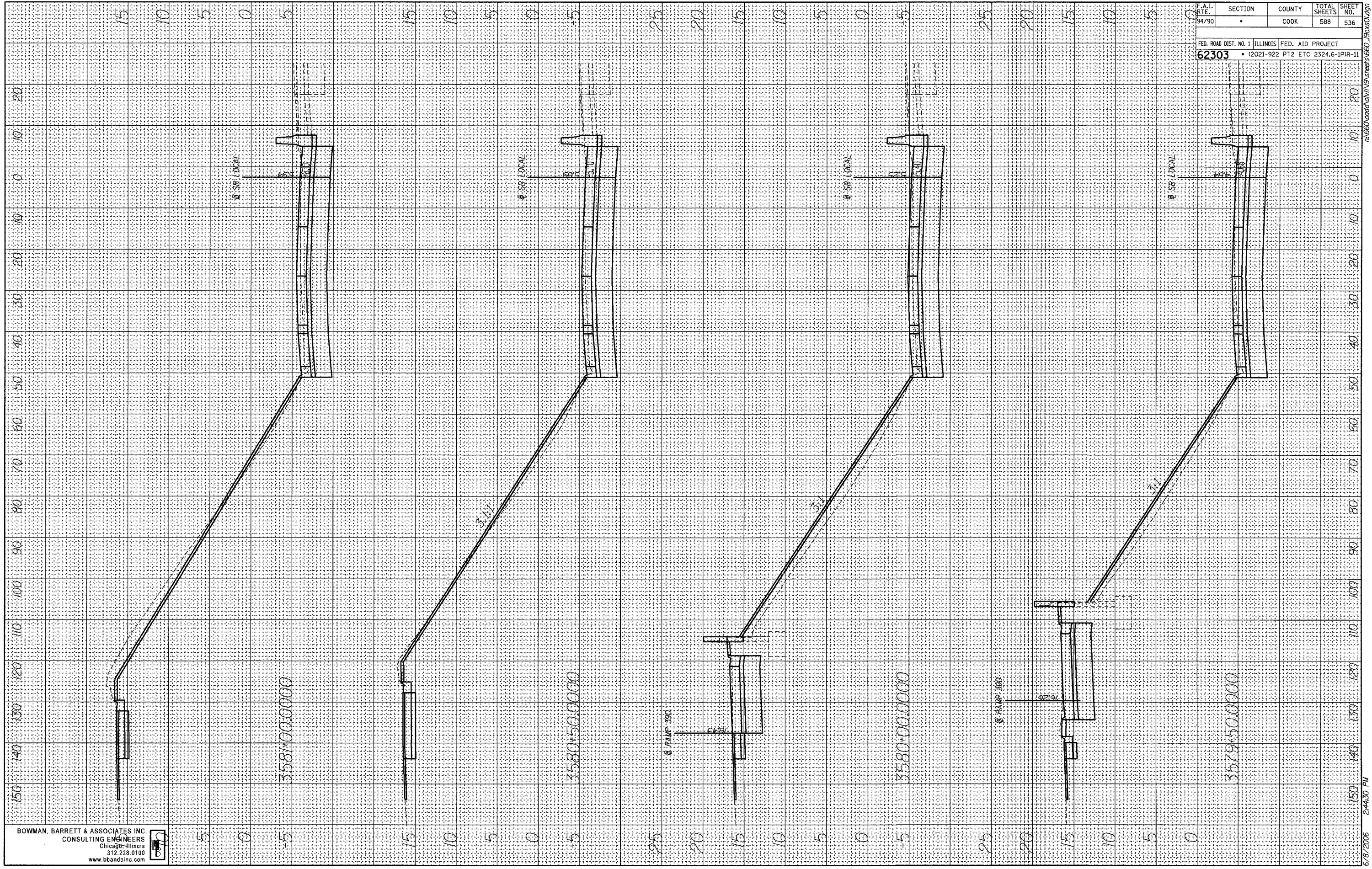

BOWMAN, BARRETT & ASSOCIATES INC.
 CONSULTING ENGINEERS
 Chicago, Illinois
 312.228.0100
 www.bbainc.com

F.A.I. R.T.E. 94/90	SECTION	COUNTY	TOTAL SHEETS	SHEET NO.
		COOK	588	536
FED. ROAD DIST. NO. 1		ILLINOIS		FED. AID PROJECT
62303		(2021-922 PT2 ETC		2324.6-1PIR-11

6/8/2006 2:44:30 PM

ORIGINAL SURVEY SURVEYED BY DATE
 SURVEY PLOTTED
 NOTE BOOK NO.
 DATE
 AREAS CHECKED

ORIGINAL SURVEY SURVEYED BY DATE
 SURVEY PLOTTED
 NOTE BOOK NO.
 DATE
 AREAS CHECKED

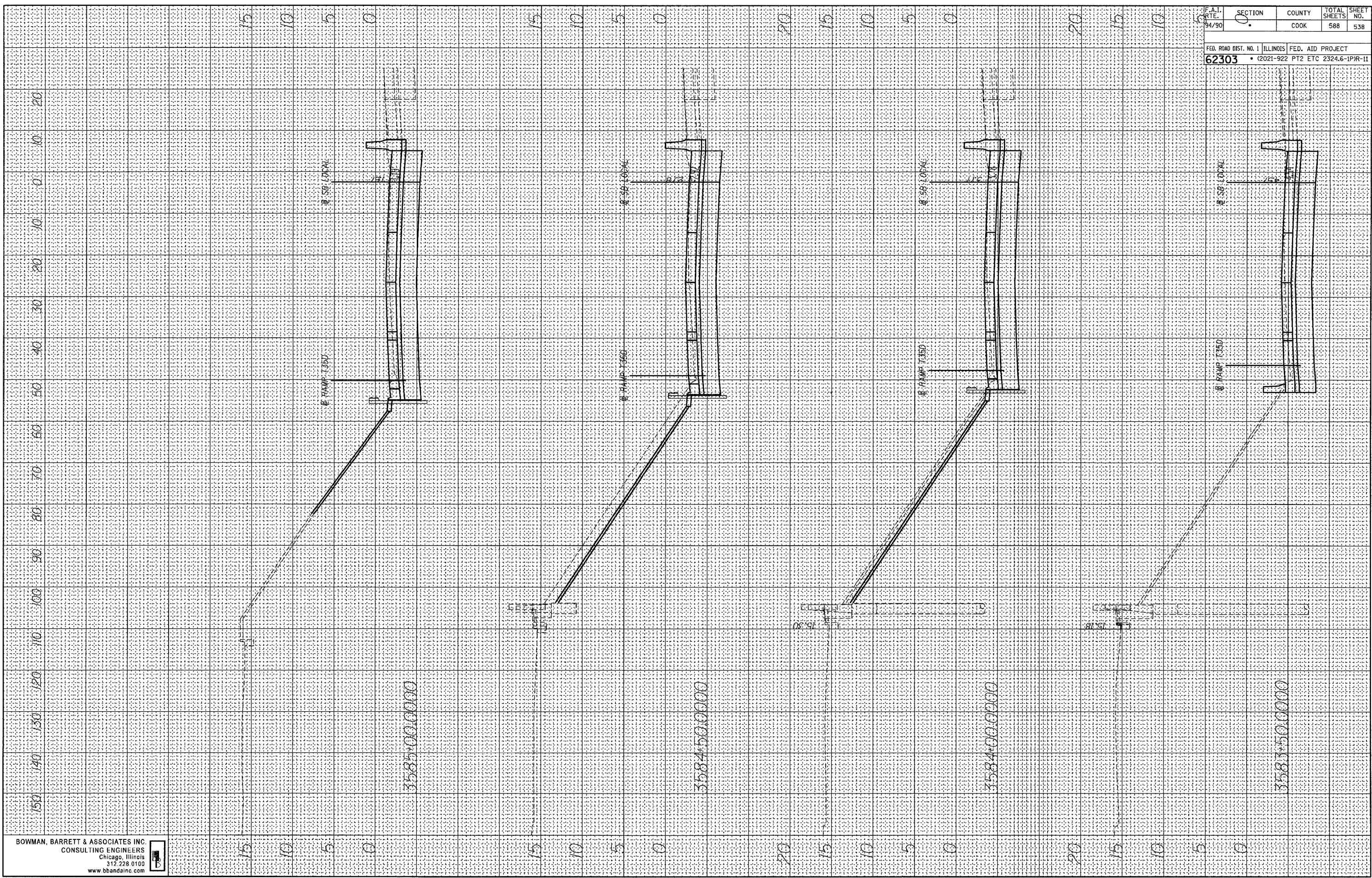

BOWMAN, BARRETT & ASSOCIATES INC.
 CONSULTING ENGINEERS
 Chicago, Illinois
 312.228.0100
 www.bbandainc.com



F.A.I. R.T.E. 94/90	SECTION 0	COUNTY COOK	TOTAL SHEETS 588	SHEET NO. 538
FED. ROAD DIST. NO. 1		ILLINOIS		FED. AID PROJECT
62303		• (2021-922 PT2 ETC 2324.6-1PR-11		

6/8/2006 2:44:32 PM 150

FINAL SURVEY SURVEYED PLOTTED NOTE BOOK NO. BY DATE

ORIGINAL SURVEY SURVEYED PLOTTED NOTE BOOK NO. BY DATE

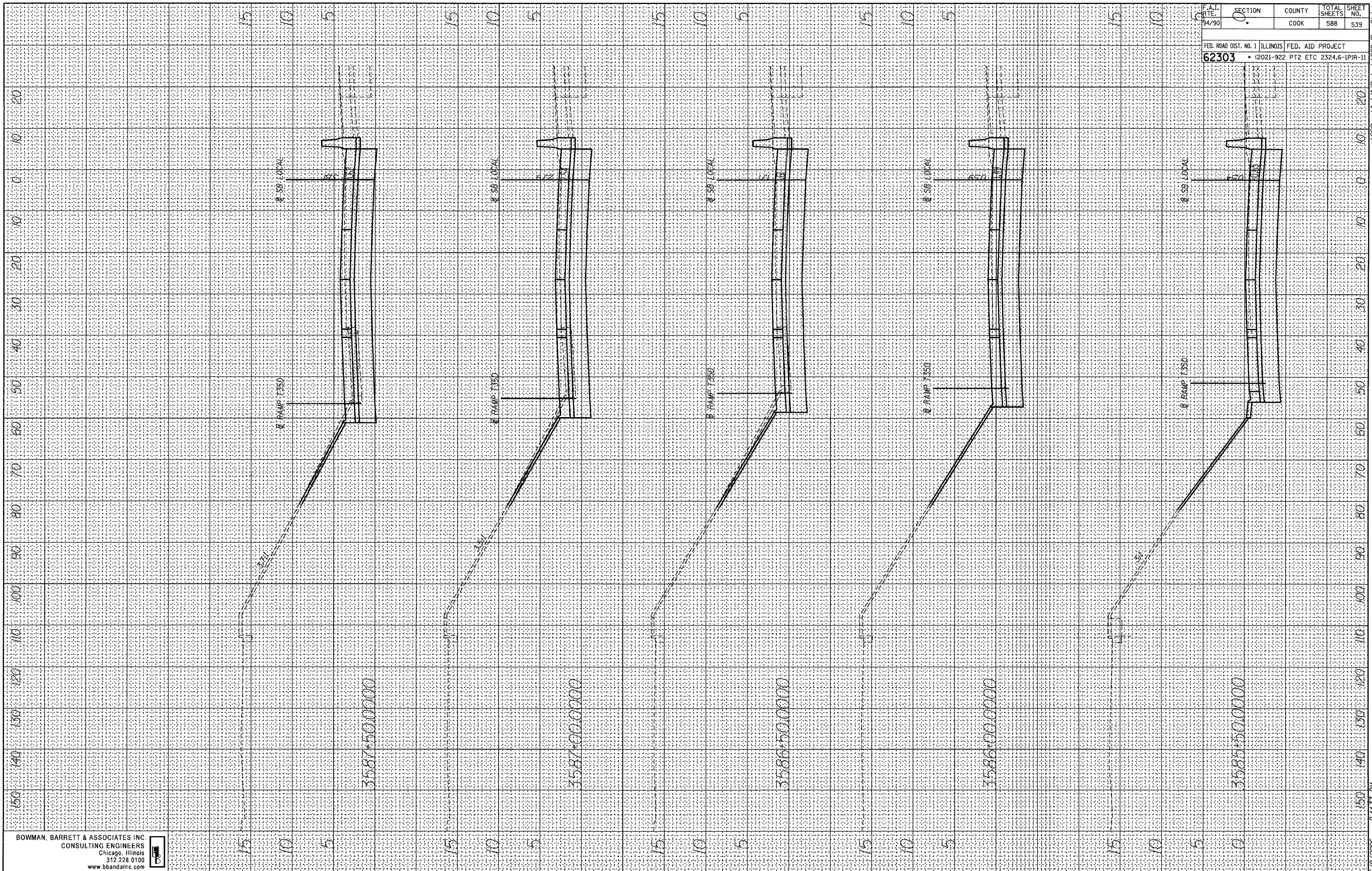

BOWMAN, BARRETT & ASSOCIATES INC.
CONSULTING ENGINEERS
Chicago, Illinois
312.228.0100
www.bbainc.com



F.A.I. RT. 94/90	SECTION 0	COUNTY COOK	TOTAL SHEETS 588	SHEET NO. 539
FED. ROAD DIST. NO. 1		ILLINOIS	FED. AID PROJECT	
62303		(2021-922 PT2 ETC	2324.6-IPR-11	

6/8/2006 2:44:33 PM T:\660\road\CHIN\9\street\660_9cxs01.dgn

FINAL SURVEY SURVEYED PLOTTED NOTE BOOK NO. BY DATE

ORIGINAL SURVEY SURVEYED PLOTTED NOTE BOOK NO. BY DATE

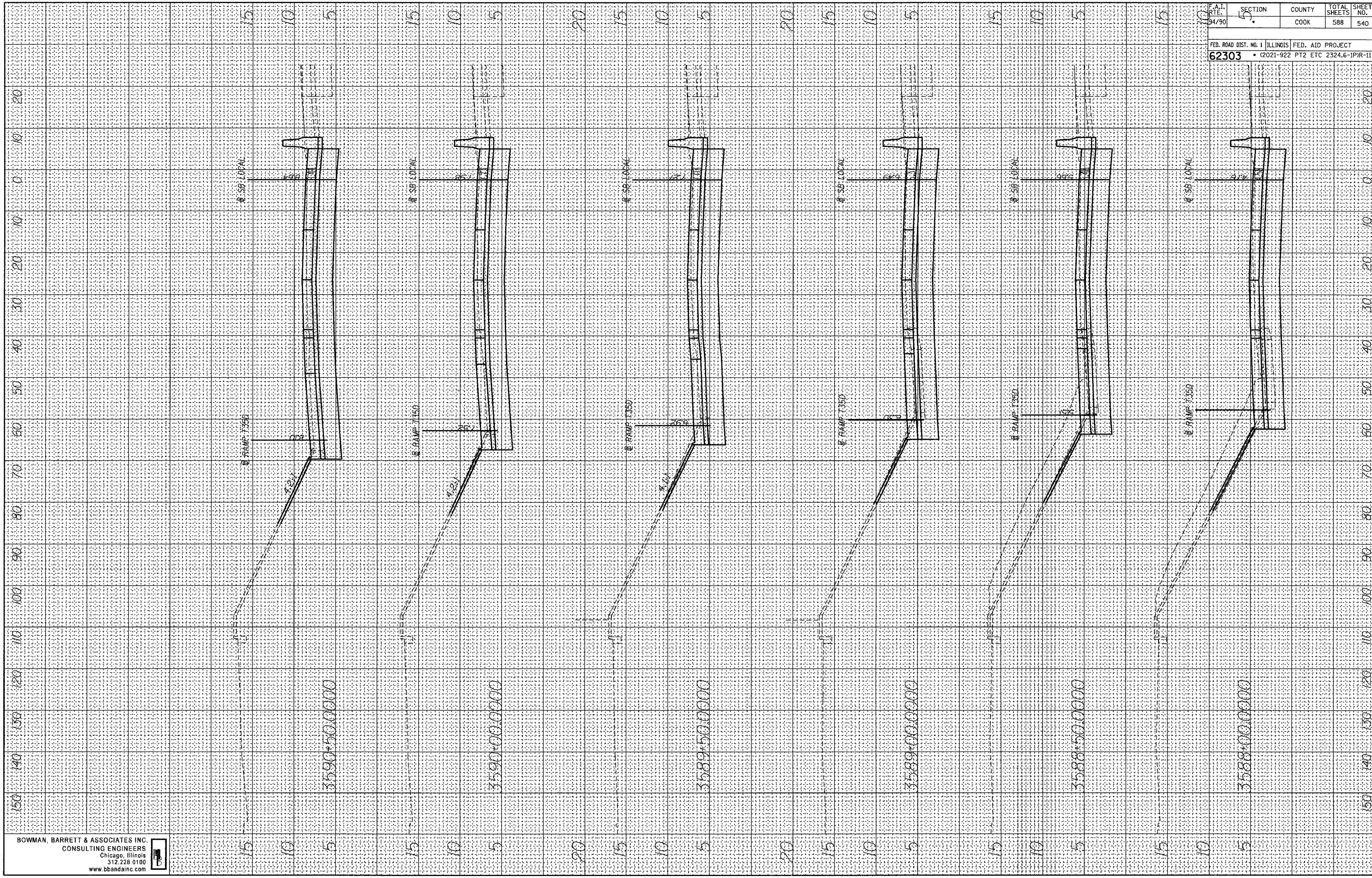

BOWMAN, BARRETT & ASSOCIATES INC.
CONSULTING ENGINEERS
Chicago, Illinois
312.228.0100
www.bbandainc.com

F.A.I. RTE. 94/90	SECTION 5	COUNTY COOK	TOTAL SHEETS 588	SHEET NO. 540
FED. ROAD DIST. NO. 1 ILLINOIS		FED. AID PROJECT		
62303		(2021-922 PT2 ETC 2324.6-IPR-II)		

6/8/2006 2:44:34 PM n:\660\road\civil\13\sheet\540.dgn

DATE _____ BY _____
 ORIGINAL SURVEY SURVEYED SURVEYED
 NOTE BOOK PLOTTED PLOTTED
 NO. TEMPLATE TEMPLATE
 AREAS CHECKED AREAS CHECKED

DATE _____ BY _____
 ORIGINAL SURVEY SURVEYED SURVEYED
 NOTE BOOK PLOTTED PLOTTED
 NO. TEMPLATE TEMPLATE
 AREAS CHECKED AREAS CHECKED

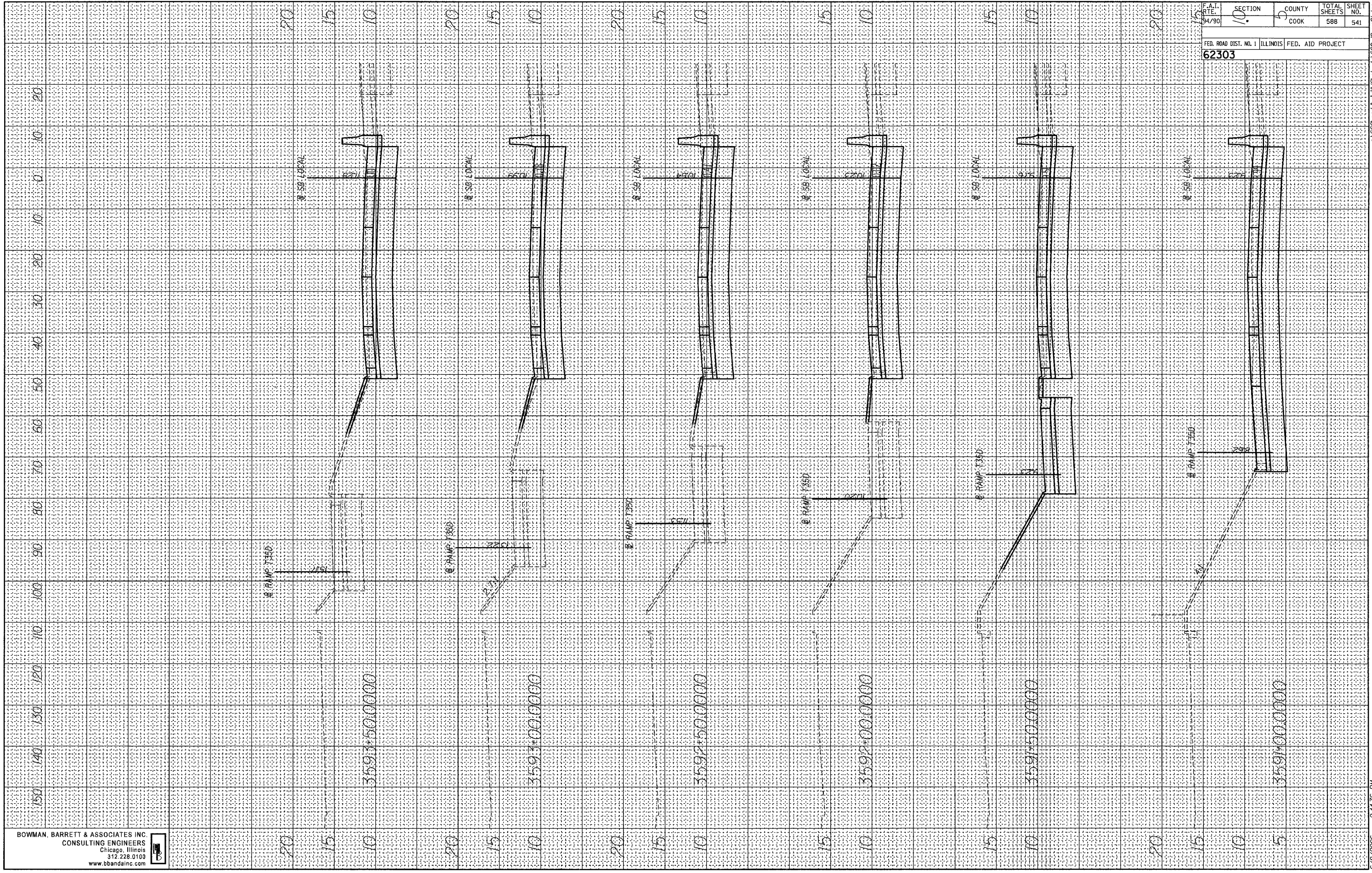

BOWMAN, BARRETT & ASSOCIATES INC.
 CONSULTING ENGINEERS
 Chicago, Illinois
 312.228.0100
 www.bbandainc.com

F.A.I. R.T.E. 94/90	SECTION 10	COUNTY COOK	TOTAL SHEETS 588	SHEET NO. 541
FED. ROAD DIST. NO. 1 ILLINOIS FED. AID PROJECT				
62303				

6/8/2006 2:44:36 PM 15.7

FINAL SURVEY SURVEYED BY DATE
 PLOTTED PLOTTED BY DATE
 NOTE BOOK NO. DATE
 AREAS CHECKED

ORIGINAL SURVEY SURVEYED BY DATE
 PLOTTED PLOTTED BY DATE
 NOTE BOOK NO. DATE
 AREAS CHECKED

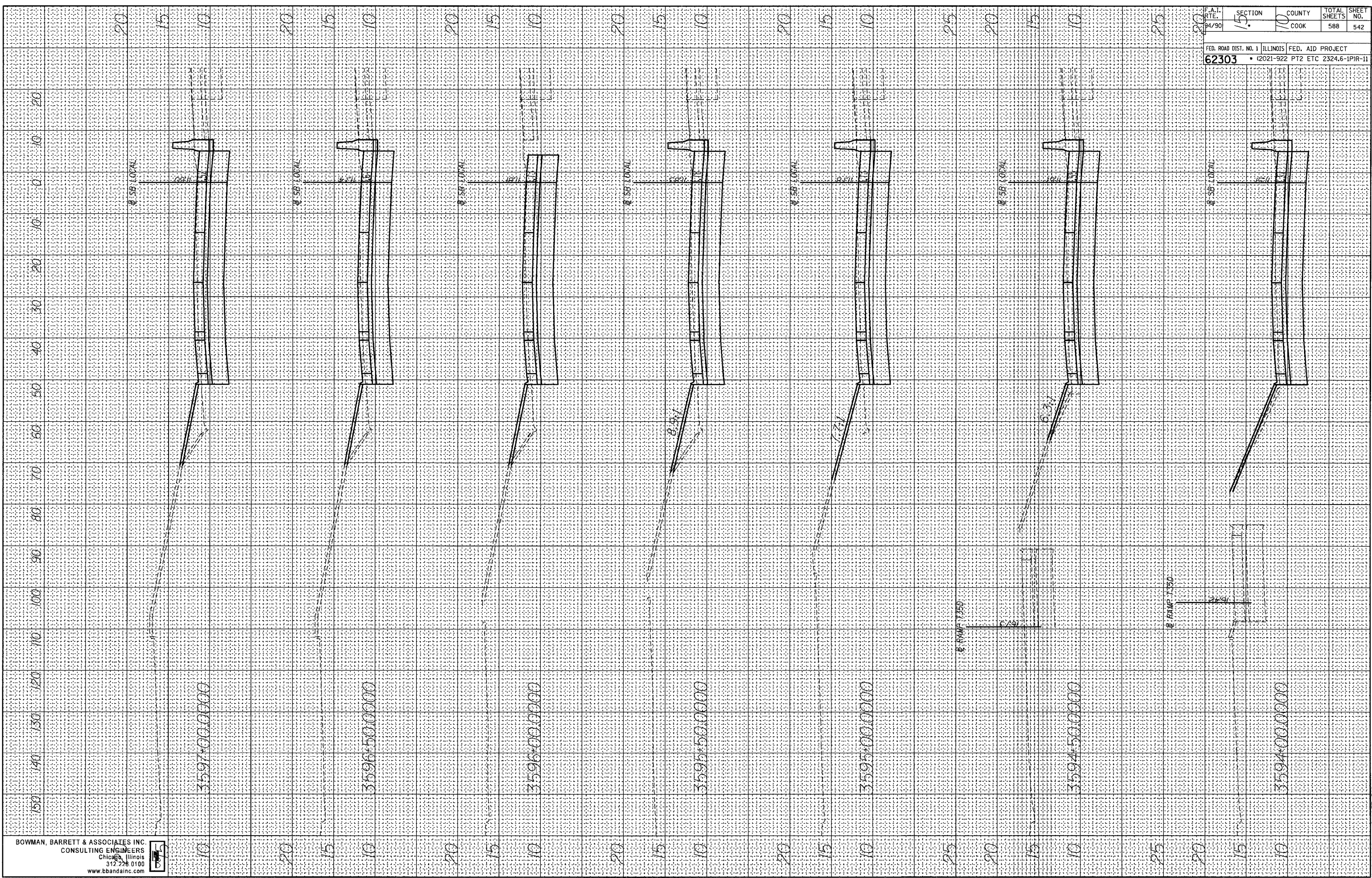

BOWMAN, BARRETT & ASSOCIATES INC.
 CONSULTING ENGINEERS
 CHICAGO, ILLINOIS
 312.278.0100
 www.bbandainc.com

F.A.I. DATE: 04/30	SECTION: 15	COUNTY: COOK	TOTAL SHEETS: 588	SHEET NO.: 542
FED. ROAD DIST. NO. 1 ILLINOIS		FED. AID PROJECT		
62303		• (2021-922 PT2 ETC 2324.6-1P1R-11		

6/8/2006 2:44:37 PM 150

FINAL SURVEY BY DATE
 SURVEYED PLOTTED
 NOTE BOOK NO. DATE
 AREAS CHECKED

ORIGINAL SURVEY BY DATE
 SURVEYED PLOTTED
 NOTE BOOK NO. DATE
 AREAS CHECKED

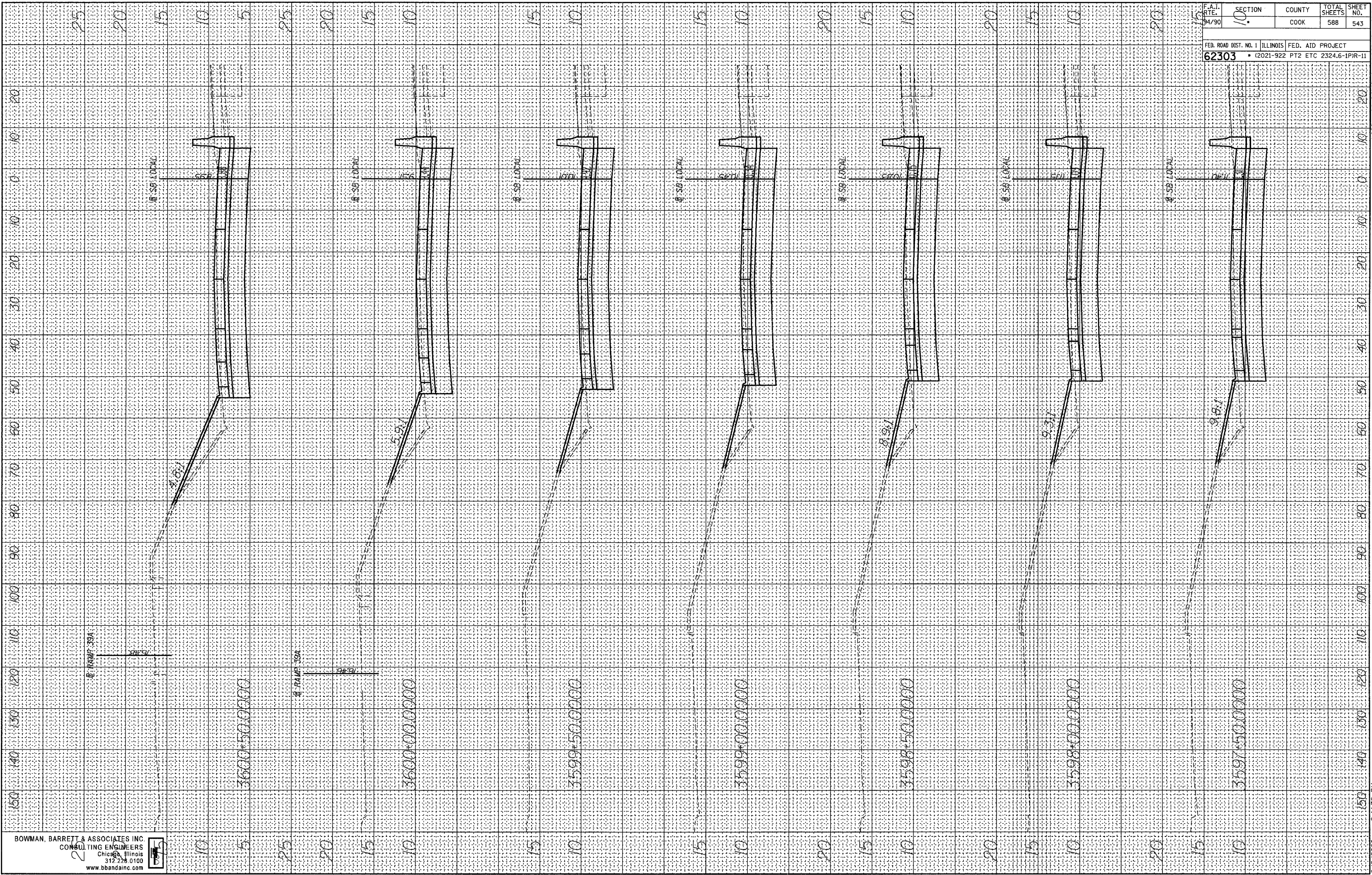

BOWMAN, BARRETT & ASSOCIATES INC
 CONSULTING ENGINEERS
 CHICAGO, ILLINOIS
 312.228.0100
 www.bbainc.com

F.A.I. RTE. 94/90	SECTION 10	COUNTY COOK	TOTAL SHEETS 588	SHEET NO. 543
FED. ROAD DIST. NO. 1		ILLINOIS FED. AID PROJECT		
62303		(2021-922 PT2 ETC 2324.6-1PIR-11		

6/8/2006 2:44:38 PM n:\680\road\civil\9 sheets\660_19x501.dgn

FINAL SURVEY SURVEYED BY DATE
 SURVEY PLOTTED BY DATE
 NOTE BOOK NO. DATE
 AREAS CHECKED

ORIGINAL SURVEY SURVEYED BY DATE
 SURVEY PLOTTED BY DATE
 NOTE BOOK NO. DATE
 AREAS CHECKED

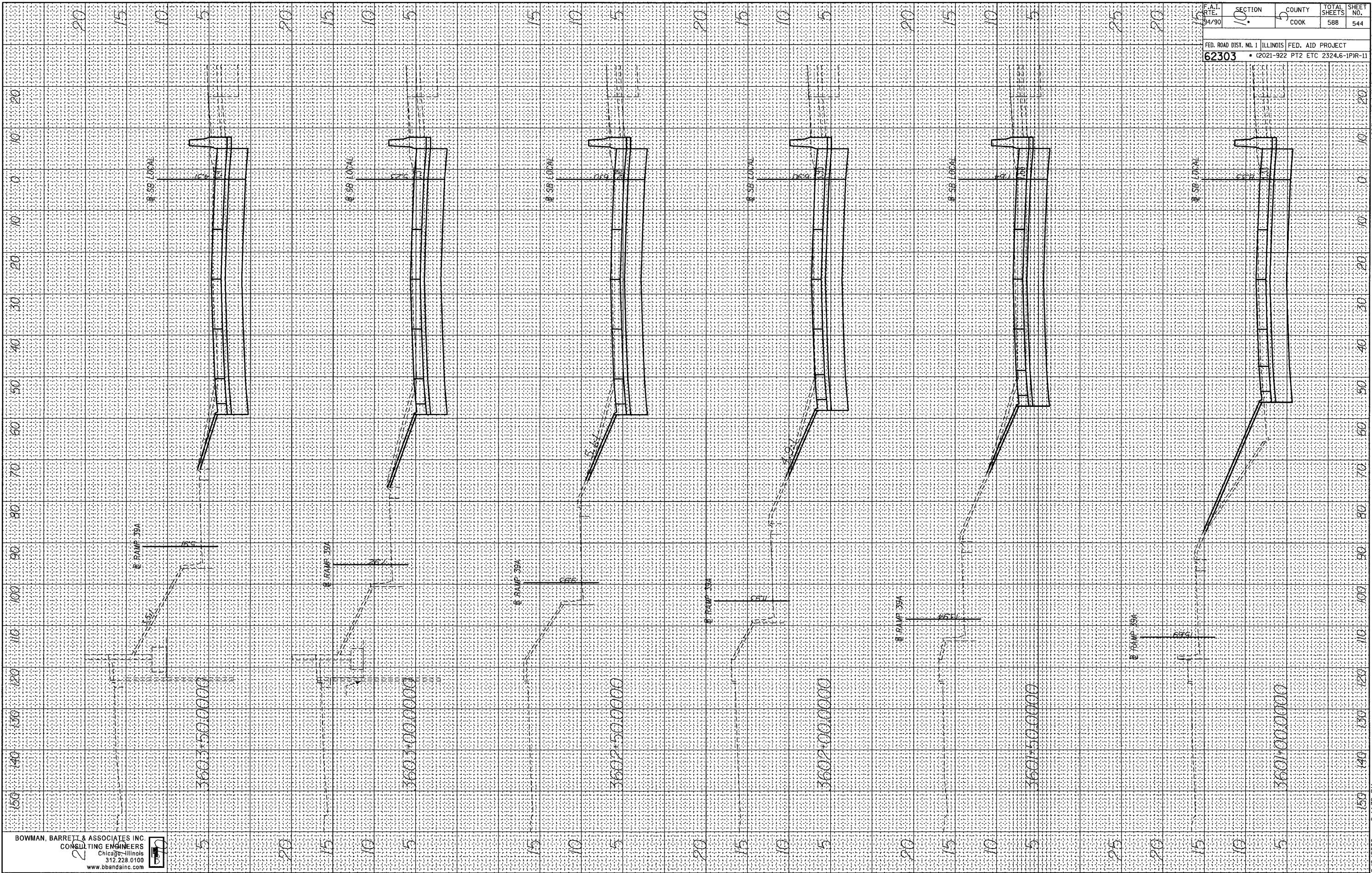

BOWMAN, BARRETT & ASSOCIATES INC.
 CONSULTING ENGINEERS
 Chicago, Illinois
 312.228.0100
 www.bbandainc.com



F.A.I. DIST. NO. 1	SECTION 10	COUNTY COOK	TOTAL SHEETS 588	SHEET NO. 544
FED. ROAD DIST. NO. 1 ILLINOIS FED. AID PROJECT				
62303 • (2021-922 PT2 ETC 2324.6-1)PR-11				

6/8/2006 2:44:39 PM n:\660\cadd\CIVIL\9 sheets\660_19a.scd.dgn

FINAL SURVEY SURVEYED PLOTTED DATE
 NOTE BOOK TEMPLATE BY
 NO. AREAS CHECKED

ORIGINAL SURVEY SURVEYED PLOTTED DATE
 NOTE BOOK TEMPLATE BY
 NO. AREAS CHECKED

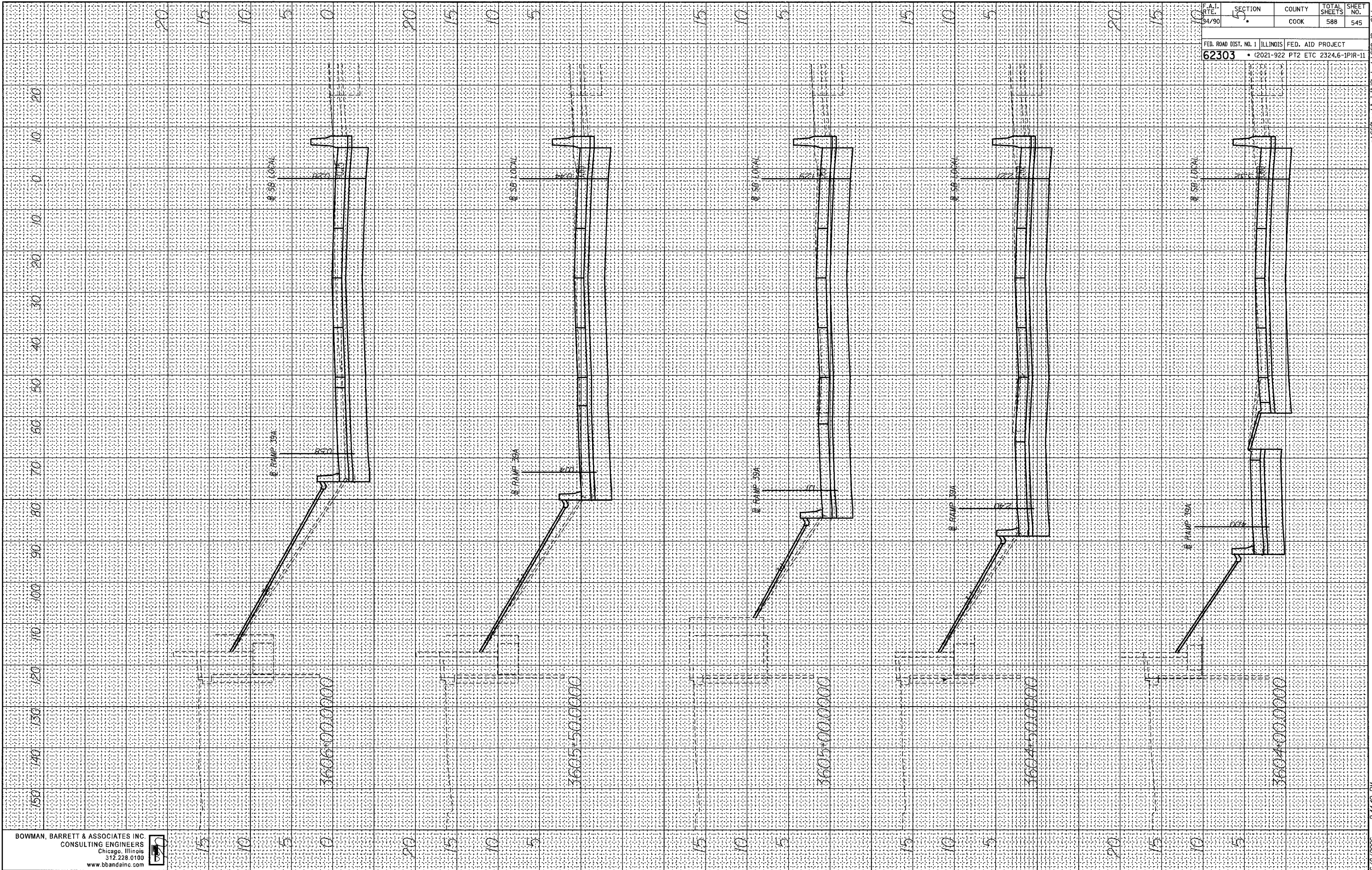

BOWMAN, BARRETT & ASSOCIATES INC.
 CONSULTING ENGINEERS
 Chicago, Illinois
 312.228.0100
 www.bbainc.com

F.A.I. R.T.E. 94/90	SECTION 5	COUNTY COOK	TOTAL SHEETS 588	SHEET NO. 545
FED. ROAD DIST. NO. 1 ILLINOIS		FED. AID PROJECT		
62303		• (2021-922 PT2 ETC 2324.6-1PIR-11		

6/8/2006 2:44:40 PM 15.7

FINAL SURVEY SURVEYED SURVEYED BY DATE
 NOTE BOOK PLOTTED PLOTTED
 NO. TEMPLATE TEMPLATE
 AREAS CHECKED AREAS CHECKED

ORIGINAL SURVEY SURVEYED SURVEYED BY DATE
 NOTE BOOK PLOTTED PLOTTED
 NO. TEMPLATE TEMPLATE
 AREAS CHECKED AREAS CHECKED

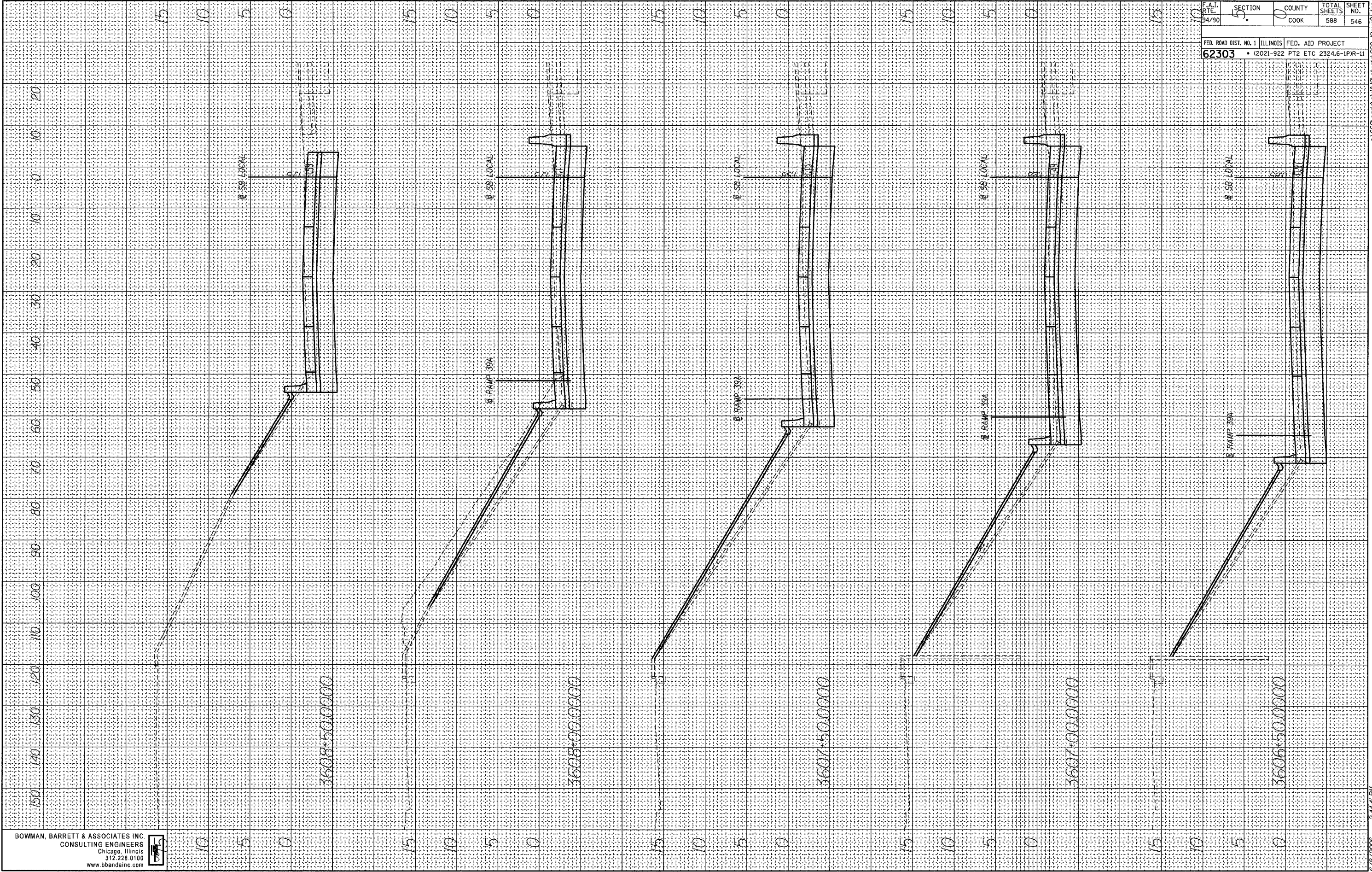

BOWMAN, BARRETT & ASSOCIATES INC.
 CONSULTING ENGINEERS
 Chicago, Illinois
 312.228.0100
 www.bbandainc.com

F.A.I. SECTION COUNTY TOTAL SHEET SHEET
 RTE. 5 0 COOK 588 546
 54/90
 FED. ROAD DIST. NO. 1 ILLINOIS FED. AID PROJECT
 62303 • (2021-922 PT2 ETC 2324.6-1PIR-11)

6/8/2006 2:44:17 PM
 150
 140
 130
 120
 110
 100
 90
 80
 70
 60
 50
 40
 30
 20
 10
 0

FINAL SURVEY SURVEYED PLOTTED NOTE BOOK AREAS CHECKED

ORIGINAL SURVEY SURVEYED PLOTTED NOTE BOOK AREAS CHECKED

BY _____ DATE _____

BY _____ DATE _____

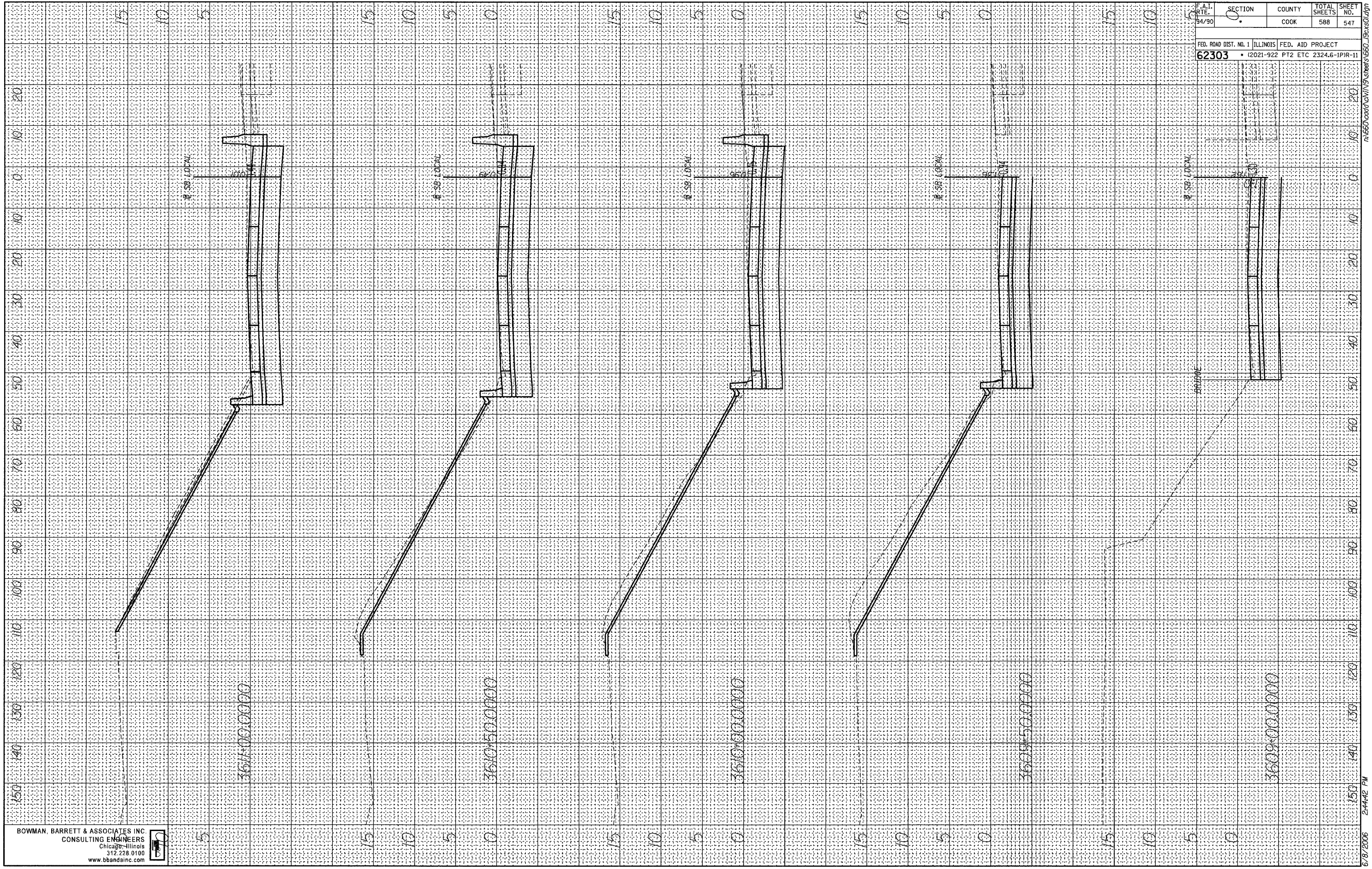

BOWMAN, BARRETT & ASSOCIATES INC
CONSULTING ENGINEERS
Chicago, Illinois
312.228.0100
www.bbainc.com



F.A.I. RT. 0	SECTION 0	COUNTY COOK	TOTAL SHEETS 588	SHEET NO. 547
FED. ROAD DIST. NO. 1 ILLINOIS		FED. AID PROJECT		
62303		PT2 ETC 2324.6-1PIR-11		

6/8/2006 2:44:42 PM

FINAL SURVEY SURVEYED BY DATE
 PLOTTED PLOTTED BY DATE
 NOTE BOOK NO. DATE
 AREAS CHECKED

ORIGINAL SURVEY SURVEYED BY DATE
 PLOTTED PLOTTED BY DATE
 NOTE BOOK NO. DATE
 AREAS CHECKED

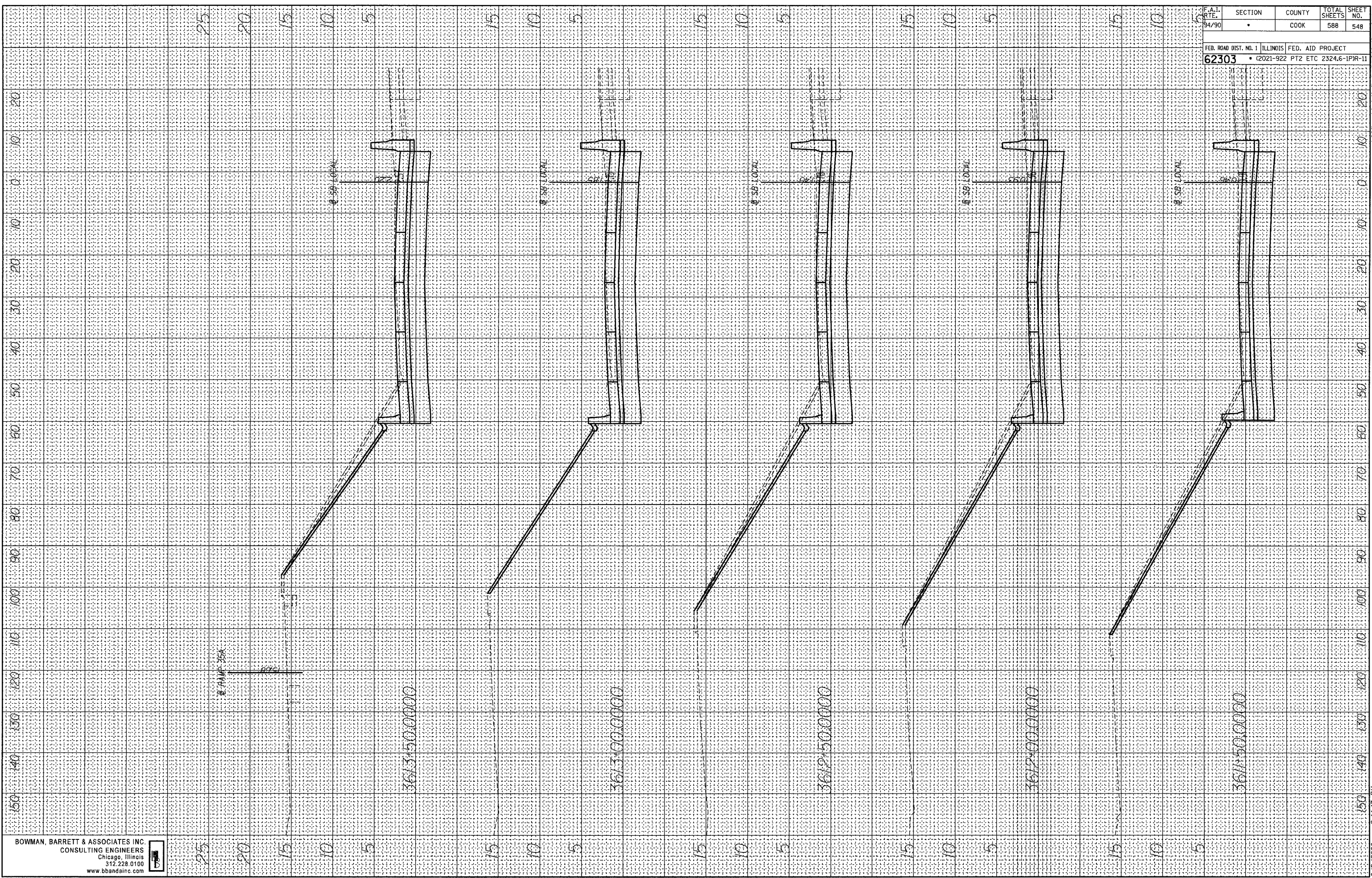

BOWMAN, BARRETT & ASSOCIATES INC.
 CONSULTING ENGINEERS
 Chicago, Illinois
 312.228.0100
 www.bbandainc.com



F.A.I. RTE. 94/90	SECTION *	COUNTY COOK	TOTAL SHEETS 588	SHEET NO. 548
FED. ROAD DIST. NO. 1 ILLINOIS FED. AID PROJECT 62303 • (2021-922 PT2 ETC 2324.6-1)PR-11				

6/8/2006 2:44:43 PM n:\660\cadd\CIVIL\9\Sheet 548.dwg

FINAL SURVEY SURVEYED BY DATE
 SURVEY PLOTTED BY DATE
 NOTE BOOK NO. DATE
 AREAS CHECKED

ORIGINAL SURVEY SURVEYED BY DATE
 SURVEY PLOTTED BY DATE
 NOTE BOOK NO. DATE
 AREAS CHECKED

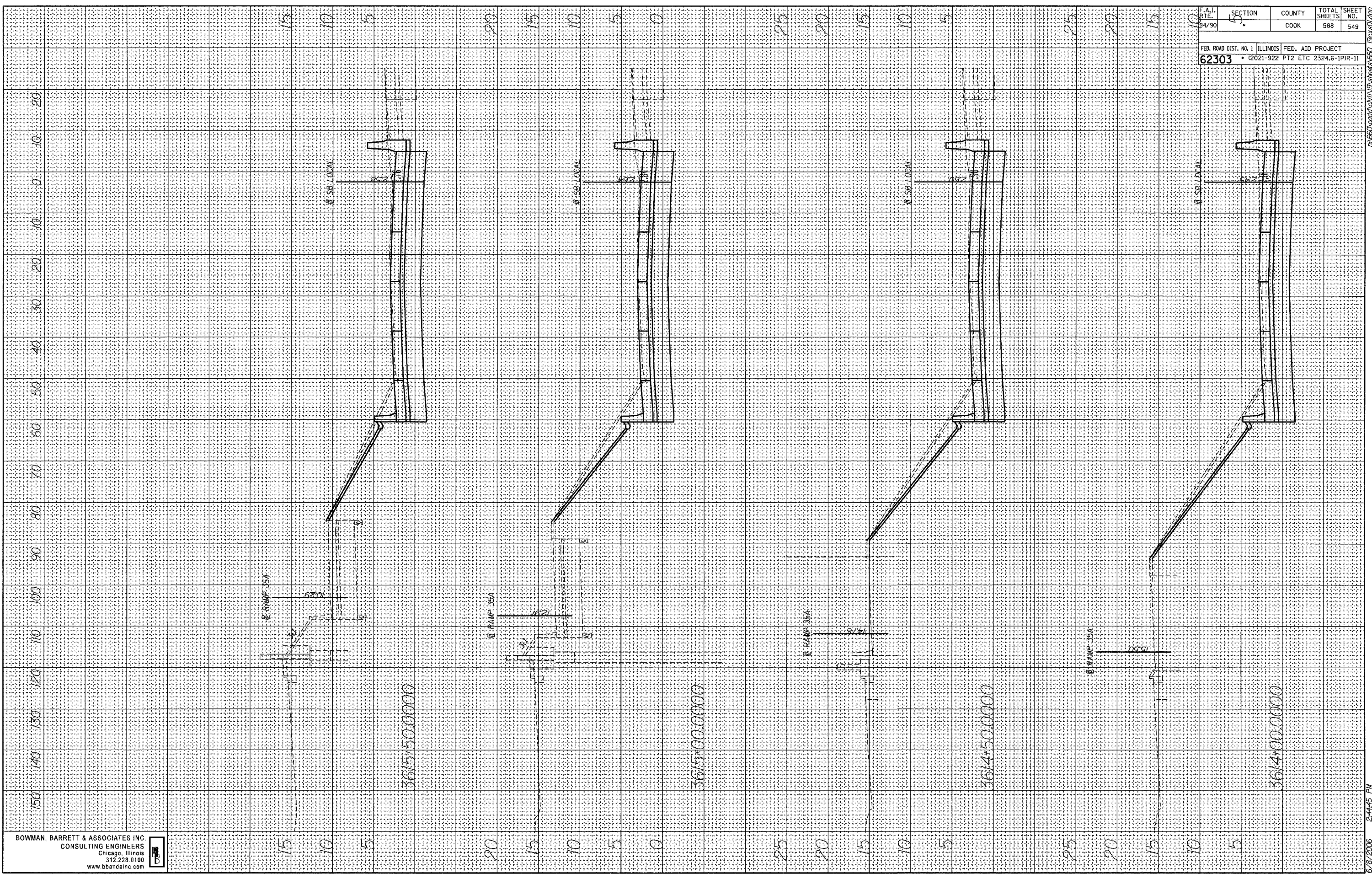

BOWMAN, BARRETT & ASSOCIATES INC.
 CONSULTING ENGINEERS
 Chicago, Illinois
 312.228.0100
 www.bbainc.com

F.A.I. DATE 9/4/90	SECTION 5	COUNTY COOK	TOTAL SHEETS 588	SHEET NO. 549
FED. ROAD DIST. NO. 1 62303		ILLINOIS	FED. AID PROJECT 2324.6-1P1R-11	

6/8/2006 2:44:45 PM

FINAL SURVEY BY DATE
 SURVEYED PLOTTED
 NOTE BOOK DATE
 NO. AREAS CHECKED

ORIGINAL SURVEY BY DATE
 SURVEYED PLOTTED
 NOTE BOOK DATE
 NO. AREAS CHECKED

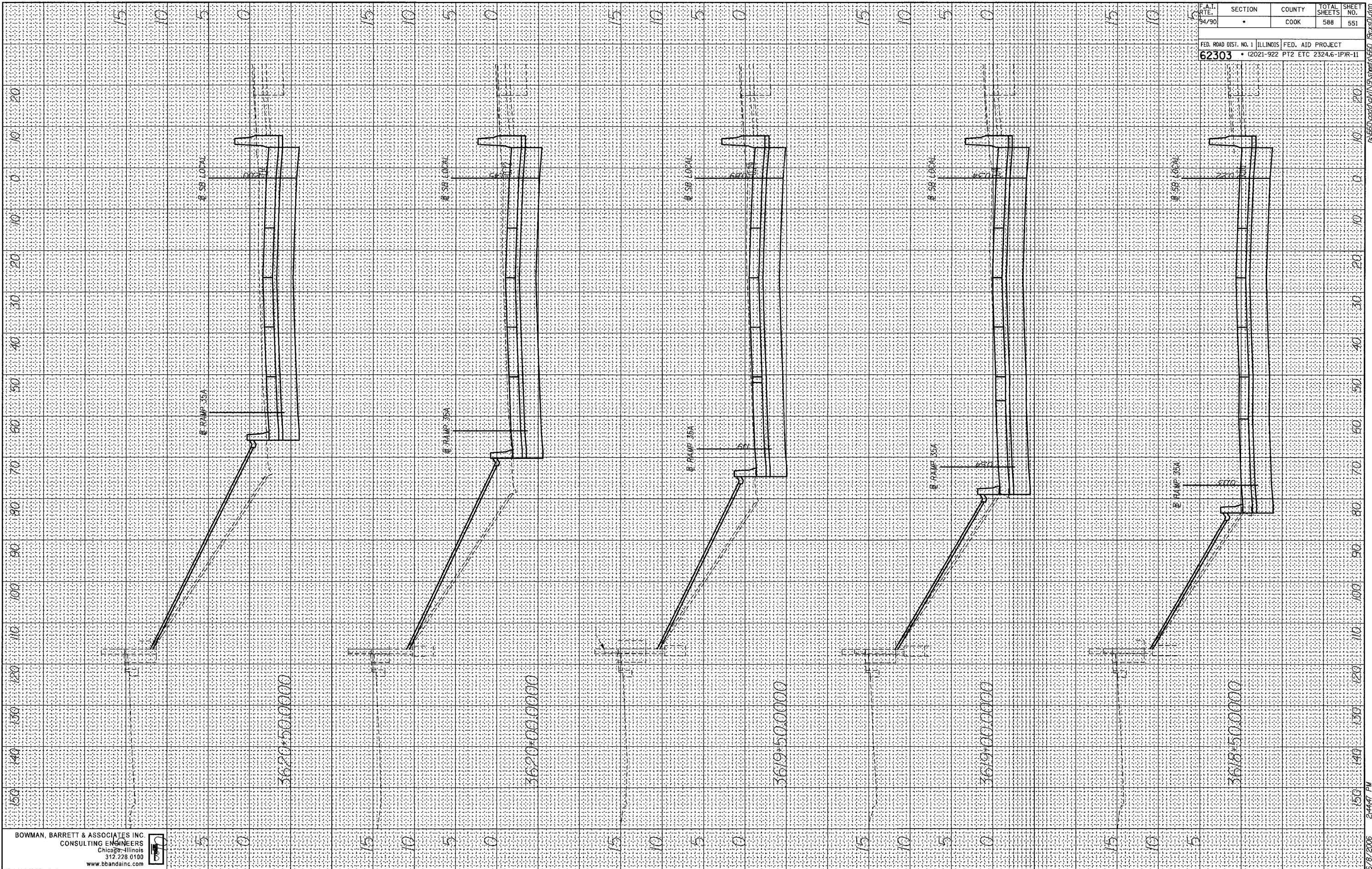

BOWMAN, BARRETT & ASSOCIATES INC.
 CONSULTING ENGINEERS
 Chicago - Illinois
 312.228.0100
 www.bbandainc.com

F.A.I. RTE.	SECTION	COUNTY	TOTAL SHEETS	SHEET NO.
94/90	*	COOK	588	551

FED. ROAD DIST. NO. 1 ILLINOIS FED. AID PROJECT
62303 • (2021-922 PT2 ETC 2324.6-IPR-11)

6/8/2006 2:44:47 PM

FINAL SURVEY
 SURVEYED _____
 PLOTTED _____
 NOTE BOOK _____
 AREAS CHECKED _____
 NO. _____

ORIGINAL SURVEY
 SURVEYED _____
 PLOTTED _____
 NOTE BOOK _____
 AREAS CHECKED _____
 NO. _____

BOWMAN, BARRETT & ASSOCIATES INC
 CONSULTING ENGINEERS
 Chicago, Illinois
 312.228.0100
 www.bbainc.com

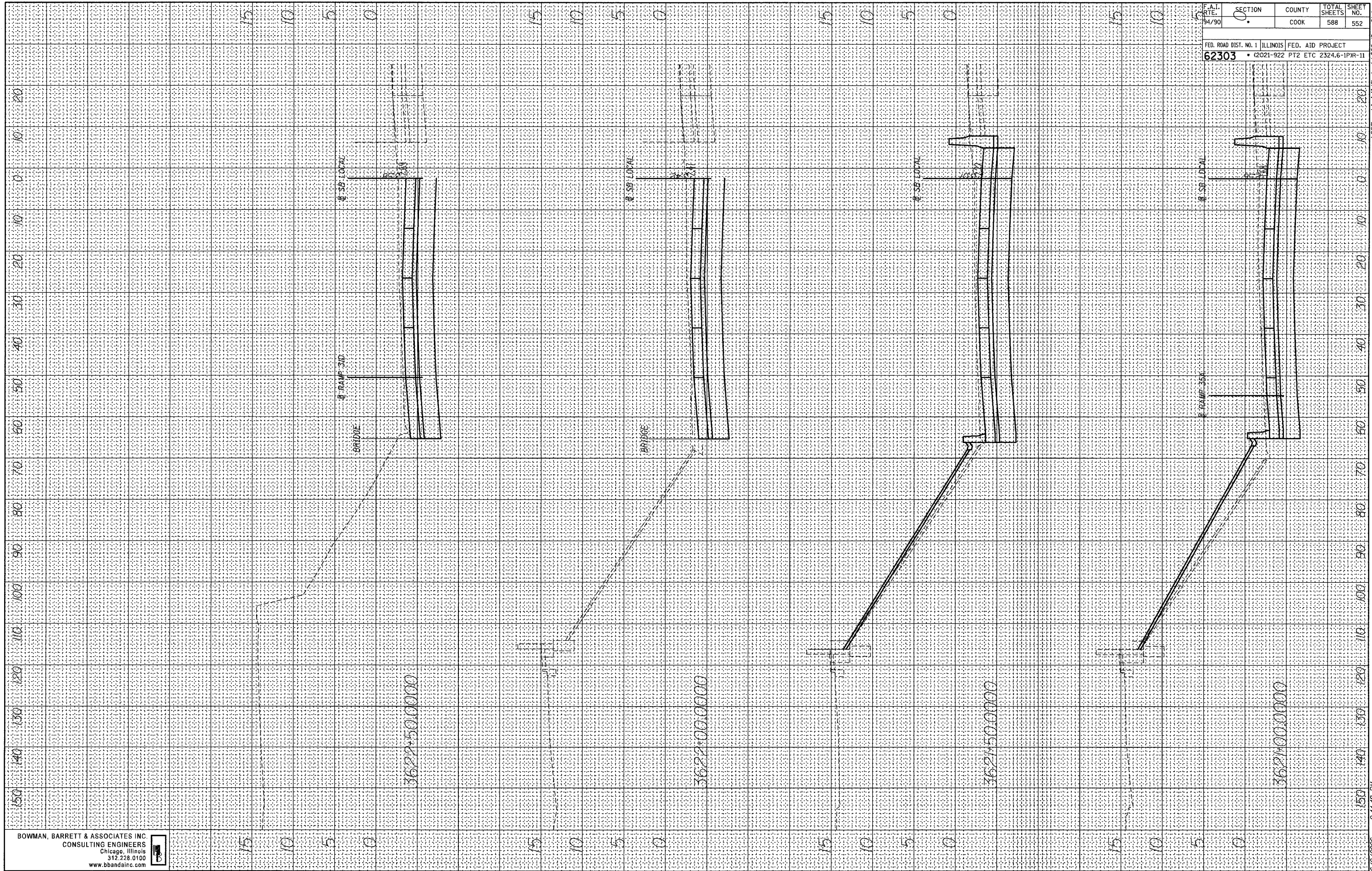

F.A.I. RT# 94/90	SECTION 0	COUNTY COOK	TOTAL SHEETS 588	SHEET NO. 552
FED. ROAD DIST. NO. 1		ILLINOIS		FED. AID PROJECT
62303		PT2 ETC		2324.6-1PR-11

6/8/2006 2:44:48 PM n:\660\cadd\civil\119\sheet\660_552.dgn

FINAL SURVEY DATE
 SURVEYED BY
 PLOTTED DATE
 NOTE BOOK NO.
 AREAS CHECKED

ORIGINAL SURVEY DATE
 SURVEYED BY
 PLOTTED DATE
 NOTE BOOK NO.
 AREAS CHECKED

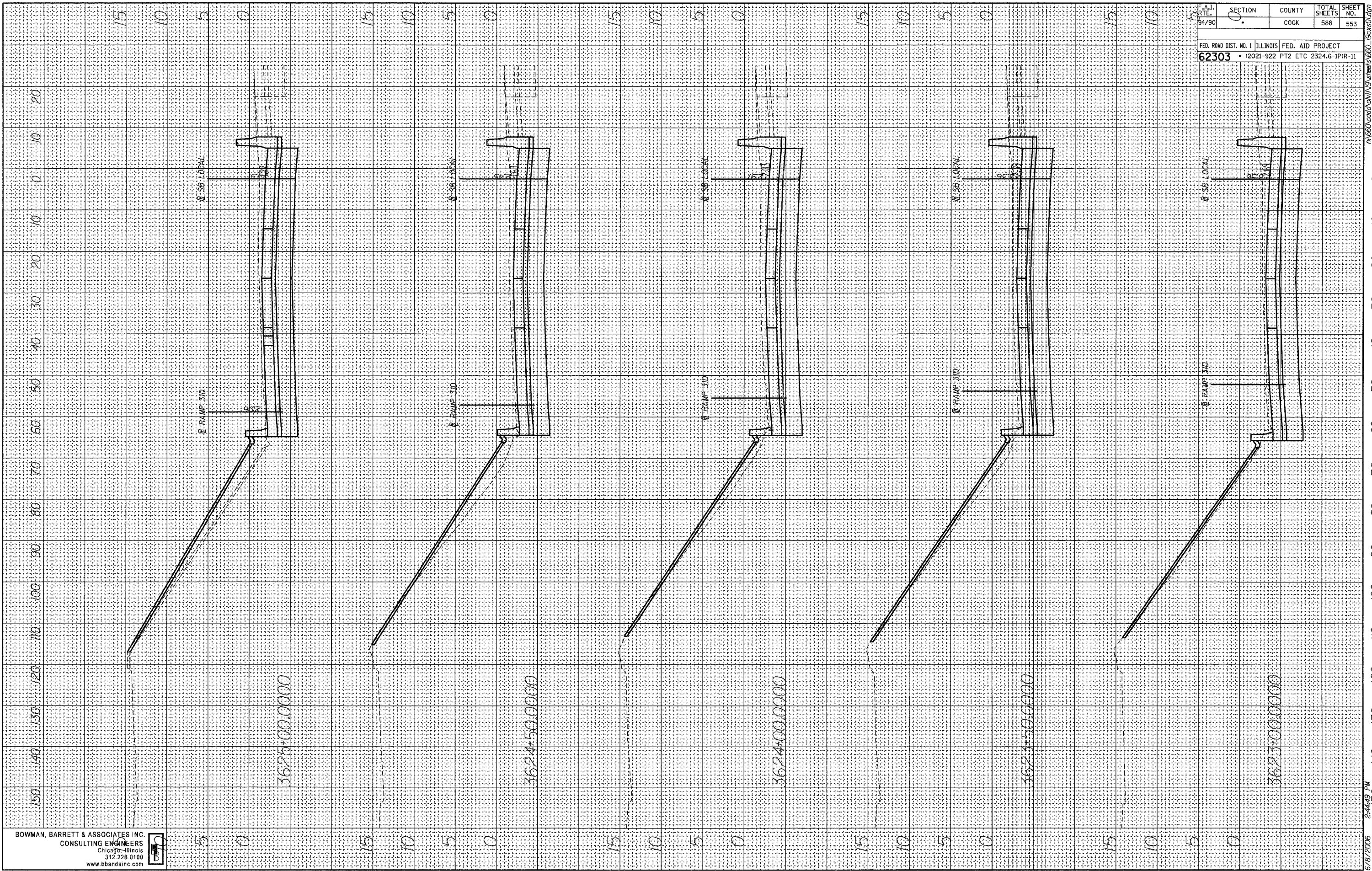

BOWMAN, BARRETT & ASSOCIATES INC.
 CONSULTING ENGINEERS
 Chicago - Illinois
 312.228.0100
 www.bbandainc.com



F.A.I. R.T.E.	SECTION	COUNTY	TOTAL SHEETS	SHEET NO.
04/90	0	COOK	588	553
FED. ROAD DIST. NO. 1		ILLINOIS FED. AID PROJECT		
62303		(2021-922 PT2 ETC 2324.6-1P)R-11		

6/8/2006 2:44:49 PM 150

FINAL SURVEY	SURVEYED	BY	DATE
SHEET	PLOTTED		
NOTE BOOK	TEMPLATE		
NO.	AREAS CHECKED		

ORIGINAL SURVEY	SURVEYED	BY	DATE
NOTE BOOK	PLOTTED		
NO.	TEMPLATE		
	AREAS CHECKED		

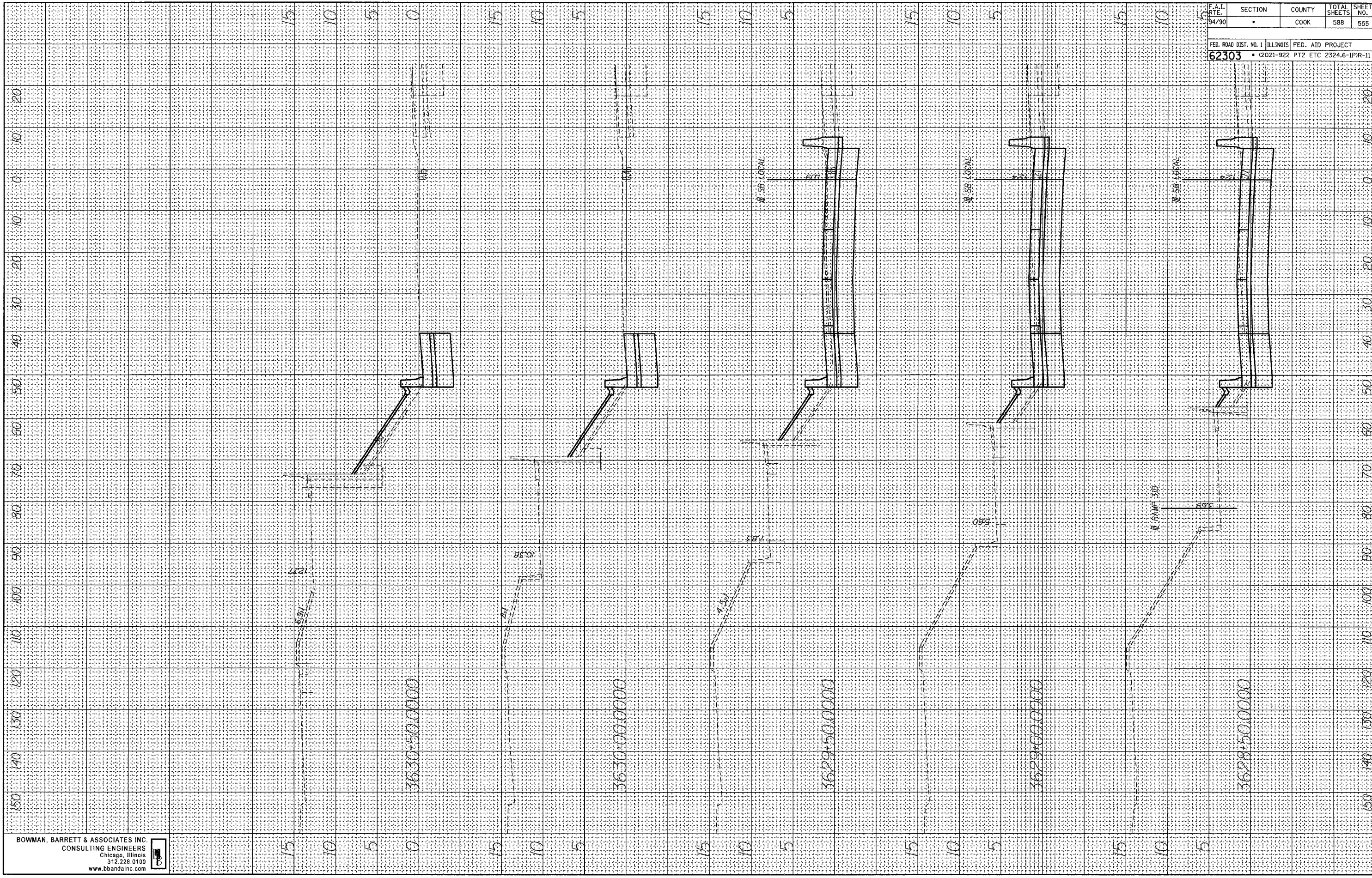

BOWMAN, BARRETT & ASSOCIATES INC.
CONSULTING ENGINEERS
Chicago, Illinois
312.228.0100
www.bbandainc.com

F.A.I. RTE.	SECTION	COUNTY	TOTAL SHEETS	SHEET NO.
94/90		COOK	588	555
FED. ROAD DIST. NO. 1		ILLINOIS	FED. AID PROJECT	
62303			2021-922 PT2 ETC 2324.6-1P1R-11	

6/8/2006 2:44:51 PM n:\660\card\c\WIN\Drawings\660_9c\ss01.dgn

FINAL SURVEY NO.	
SURVEYED PLOTTED	
NOTE BOOK TEMPLATE	
AREAS CHECKED	
BY	
DATE	

ORIGINAL SURVEY NO.	
SURVEYED PLOTTED	
NOTE BOOK TEMPLATE	
AREAS CHECKED	
BY	
DATE	

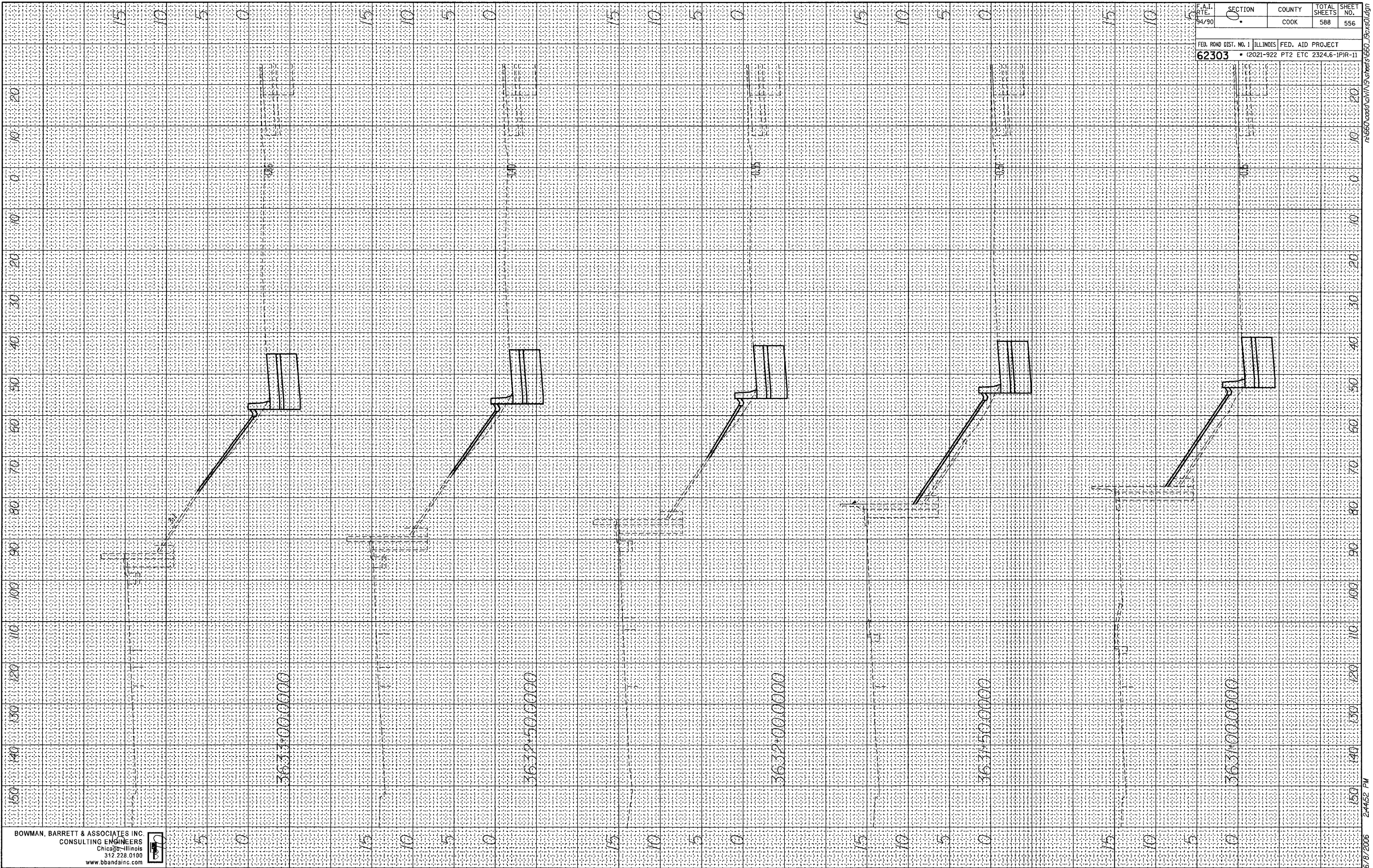

BOWMAN, BARRETT & ASSOCIATES INC.
CONSULTING ENGINEERS
Chicago, Illinois
312.228.0100
www.bbainc.com



F.A.I. RTE. 94/90	SECTION 1	COUNTY COOK	TOTAL SHEETS 588	SHEET NO. 556
FED. ROAD DIST. NO. 1		ILLINOIS	FED. AID PROJECT	
62303		(2021-922	PT2 ETC 2324.6-1P)R-11	

6/8/2006 2:44:52 PM r:\660\card\dwg\9\shere's\660_9cxs21.dgn

FINAL SURVEY
 DRAWING NO. _____
 DATE _____
 BY _____
 CHECKED BY _____
 DATE _____
 BY _____

ORIGINAL SURVEY
 DRAWING NO. _____
 DATE _____
 BY _____
 CHECKED BY _____
 DATE _____
 BY _____

F.A.I. DIST. NO.	SECTION	COUNTY	TOTAL SHEETS	SHEET NO.
62303	0	COOK	588	557
FED. ROAD DIST. NO. 1		ILLINOIS		FED. AID PROJECT
62303		(2021-222 PT2 ETC		2324.6-1PR-11

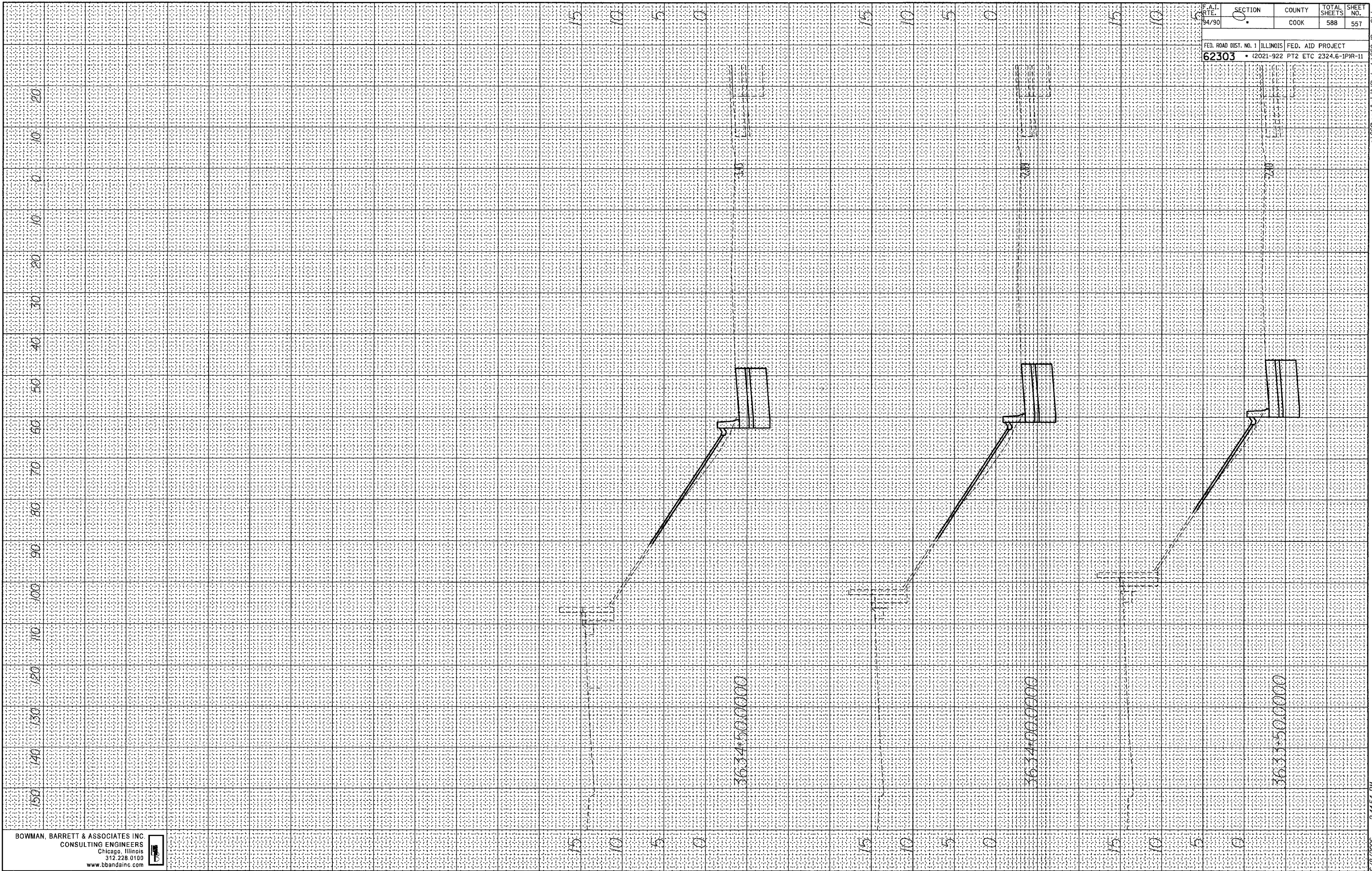

BOWMAN, BARRETT & ASSOCIATES INC
 CONSULTING ENGINEERS
 Chicago, Illinois
 312.228.0100
 www.bbandainc.com



6/8/2006 2:44:54 PM 150

F.A.I.	SECTION	COUNTY	TOTAL SHEETS	SHEET NO.
94/90	*	COOK	588	558
STA. 3530+00.00		TO STA. 3637+00.00		
FED. ROAD DIST. NO.	ILLINOIS	FED. AID PROJECT		

62303

PROFILE	REVIEWED	BY	DATE
NOTE BOOK	DESIGNED		
NO.	CHECKED		
	REV. NOTED		
	STRUCTURE NOTATING		
	CRD		

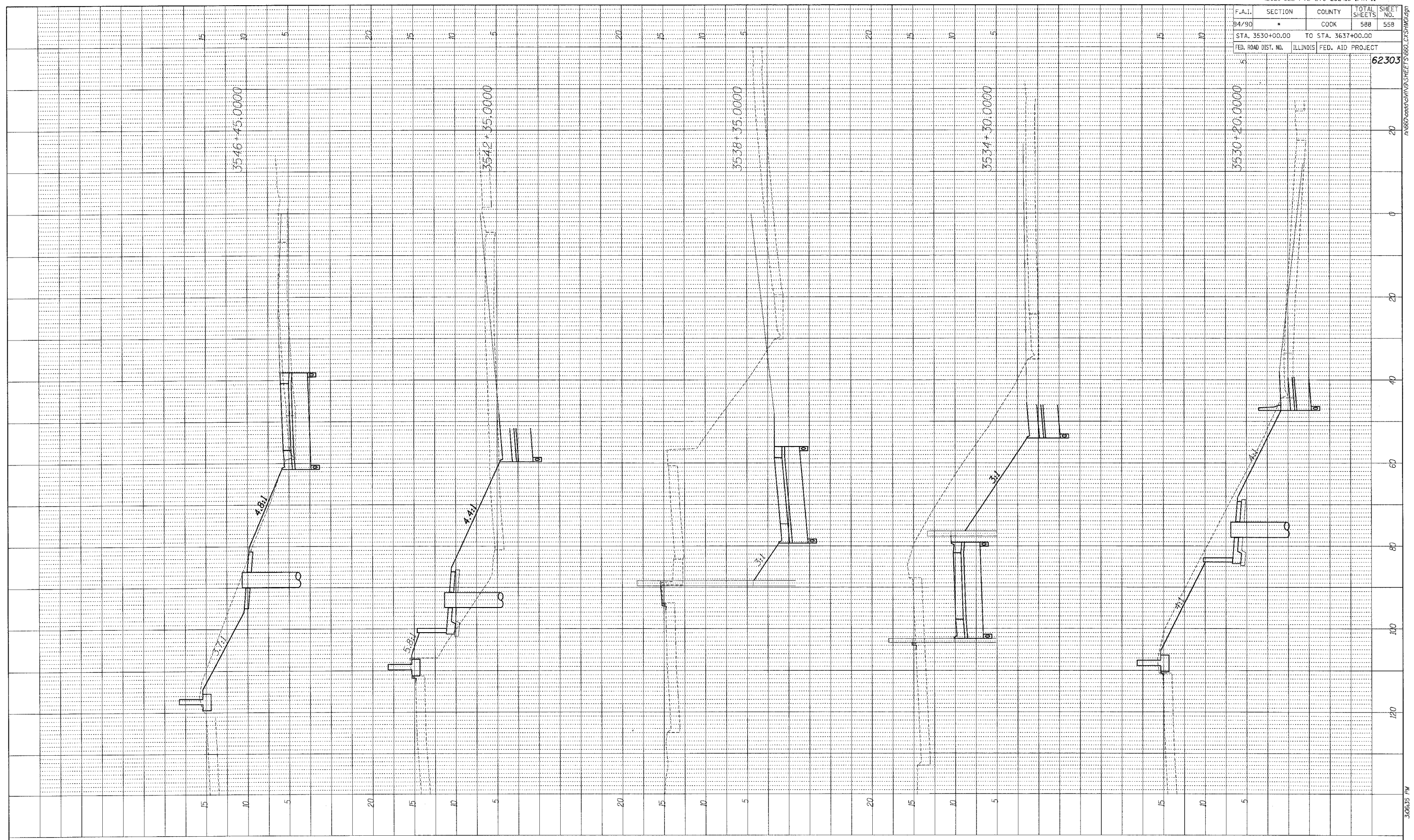

BOWMAN, BARRETT & ASSOCIATES INC.
 CONSULTING ENGINEERS
 Chicago, Illinois
 312.228.0100
 www.bbainc.com

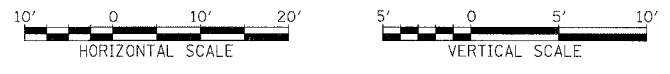

F.A.I.	SECTION	COUNTY	TOTAL SHEETS	SHEET NO.
94/90	*	COOK	588	559
STA. 3530+00.00		TO STA. 3637+00.00		
FED. ROAD DIST. NO.	ILLINOIS FED. AID PROJECT		62303	

PROFILE	SURVEYED	BY	DATE
NOTE BOOK	PROFILES CHECKED		
NO.	BY, NOTED		
	STRUCTURE NOTATIONS CHRD.		

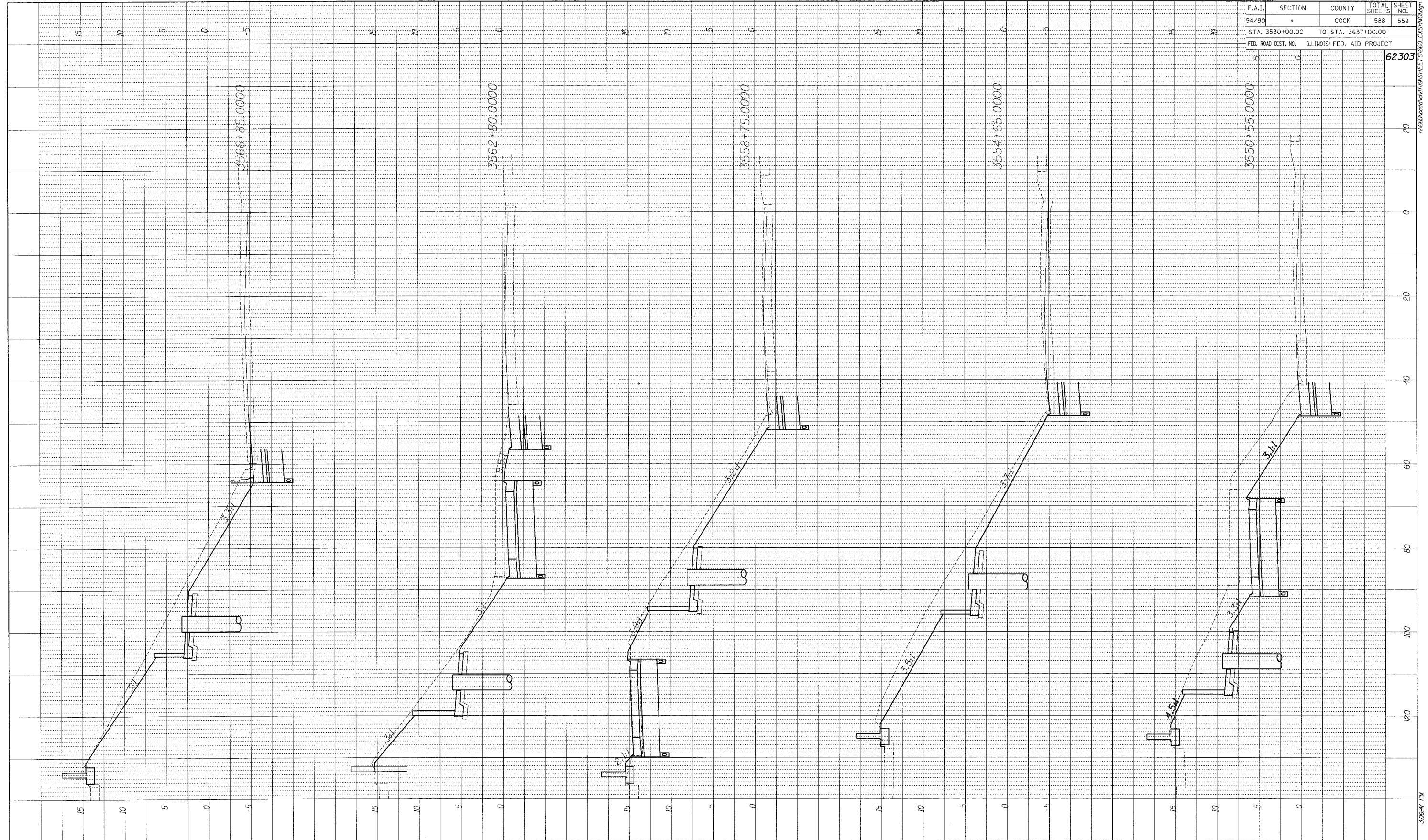

BOWMAN, BARRETT & ASSOCIATES INC
 CONSULTING ENGINEERS
 Chicago, Illinois
 312.228.0100
 www.bbainc.com

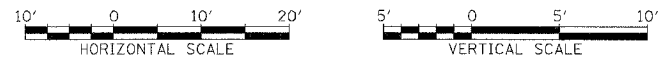

6/8/2006 3:06:47 PM

F.A.I.	SECTION	COUNTY	TOTAL SHEETS	SHEET NO.
94/90	*	COOK	588	560
STA. 3530+00.00		TO STA. 3637+00.00		
FED. ROAD DIST. NO.		ILLINOIS FED. AID PROJECT		

62303

PROFILE	SURVEYED	BY	DATE
PLOTTED	CHECKED		
NOTE BOOK	BLANK NOTED		
NO.	STRUCTURE NOTATING OFFNO		

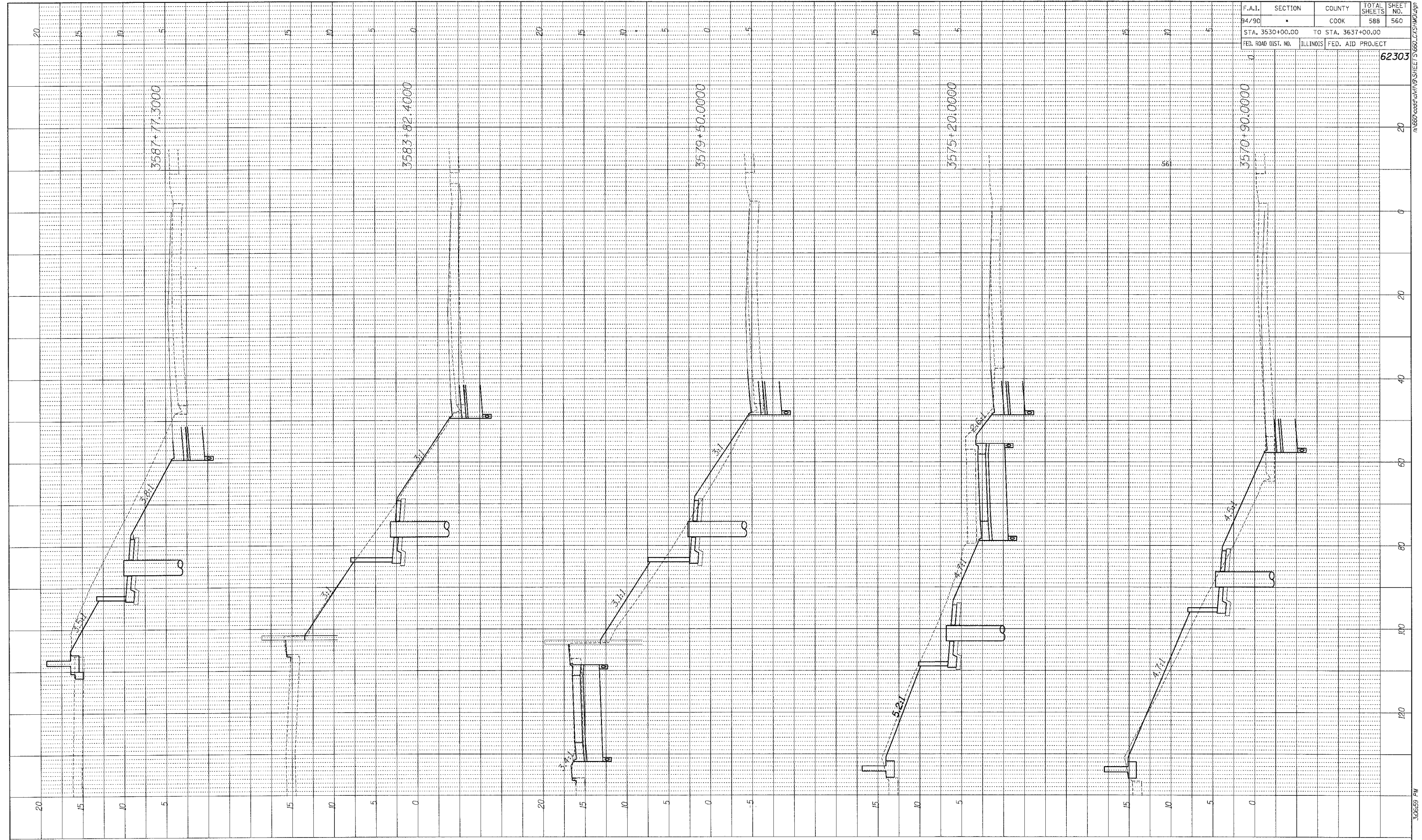

BOWMAN, BARRETT & ASSOCIATES INC.
 CONSULTING ENGINEERS
 Chicago, Illinois
 312.228.0100
 www.bbainc.com



F.A.I.	SECTION	COUNTY	TOTAL SHEETS	SHEET NO.
94/90	*	COOK	588	561
STA. 3530+00.00		TO STA. 3637+00.00		
FED. ROAD DIST. NO.	ILLINOIS	FED. AID PROJECT		
				62303

PROFILE
 SURVEYED BY _____ DATE _____
 PLOTTED BY _____
 NOTE BOOK NO. _____
 DRAWING NO. _____
 STRUCTURE NOTATIONS CHRD

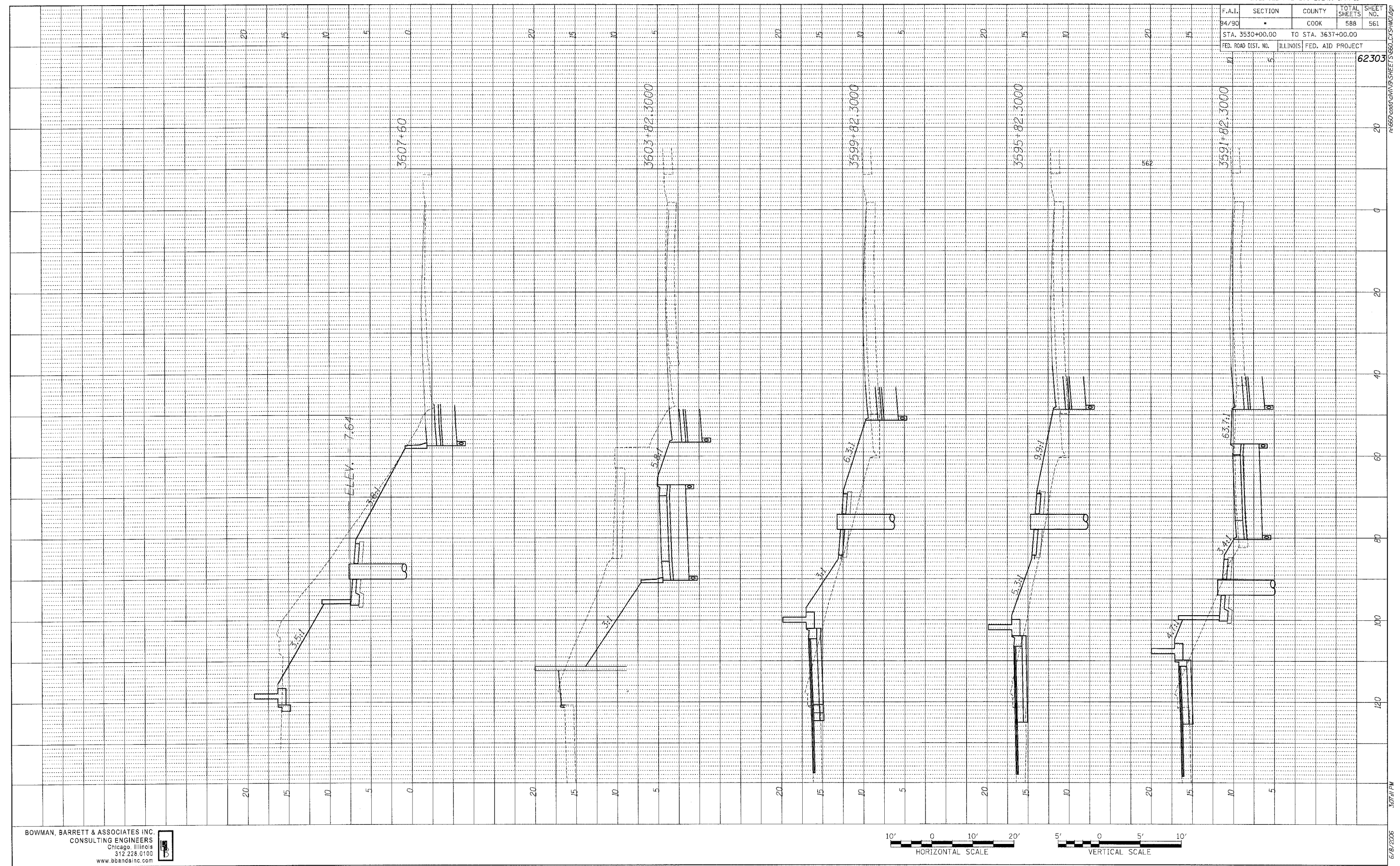

BOWMAN, BARRETT & ASSOCIATES INC.
 CONSULTING ENGINEERS
 Chicago, Illinois
 312.228.0100
 www.bbainc.com



F.A.I.	SECTION	COUNTY	TOTAL SHEETS	SHEET NO.
94/90	*	COOK	588	562
STA. 3530+00.00		TO STA. 3637+00.00		
FED. ROAD DIST. NO.	ILLINOIS FED. AID PROJECT		62303	

PROFILE	DESIGNED	BY	DATE
NOTE BOOK	PLOTTED		
NO.	CHECKED		
	STRUCTURE NOTATION CRND		

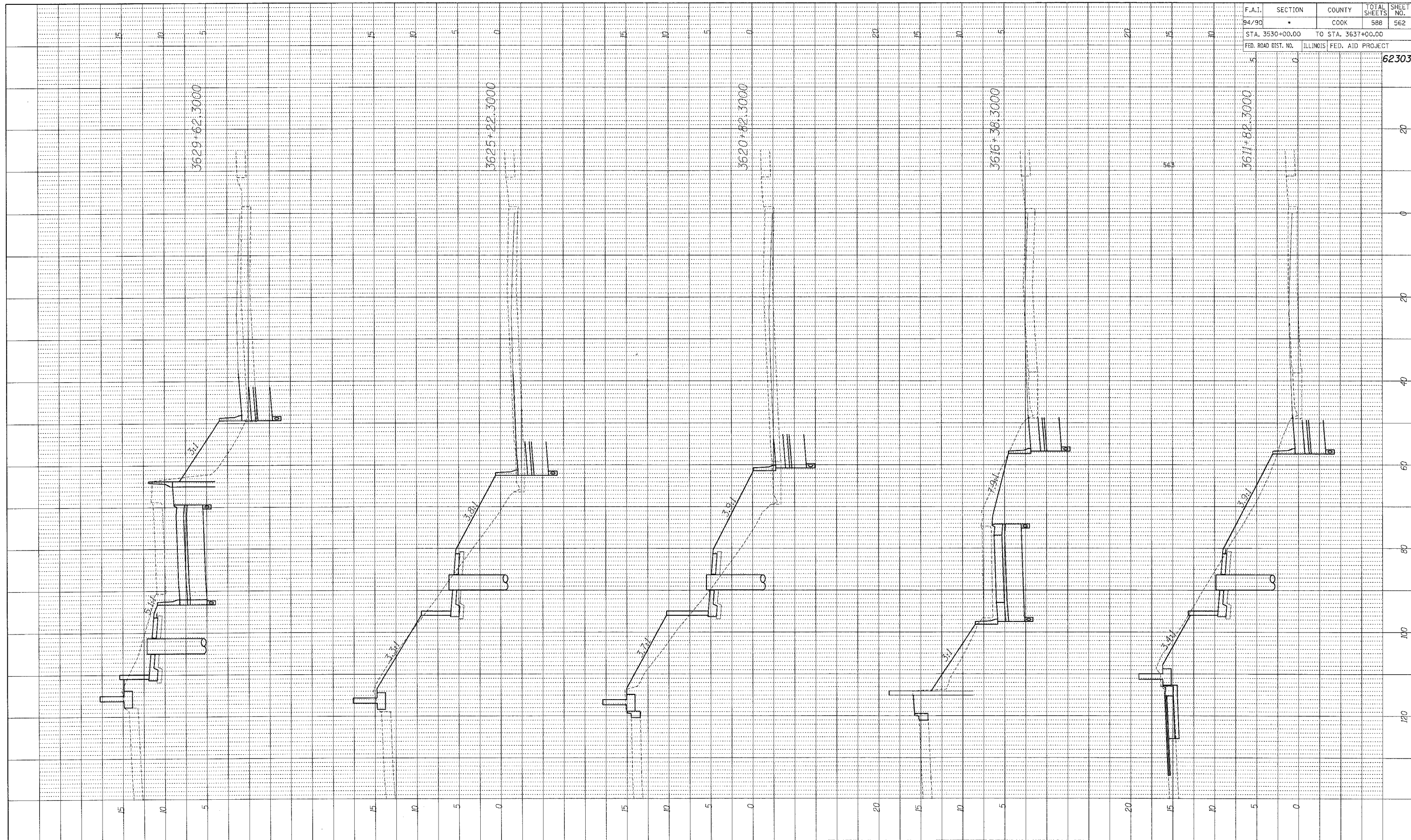

BOWMAN, BARRETT & ASSOCIATES INC
 CONSULTING ENGINEERS
 Chicago, Illinois
 312.228.0100
 www.bbandainc.com



F.A.I.	SECTION	COUNTY	TOTAL SHEETS	SHEET NO.
94/90	•	COOK	588	563
STA. 3530+00.00		TO STA. 3637+00.00		
FED. ROAD DIST. NO.	ILLINOIS	FED. AID PROJECT		
5	5	62303		

PROFILE	SURVEYED	BY	DATE
PLOTTED	CHECKED		
NOTE BOOK	NO.		
	STRUCTURE	NOTATIONS	CHORD

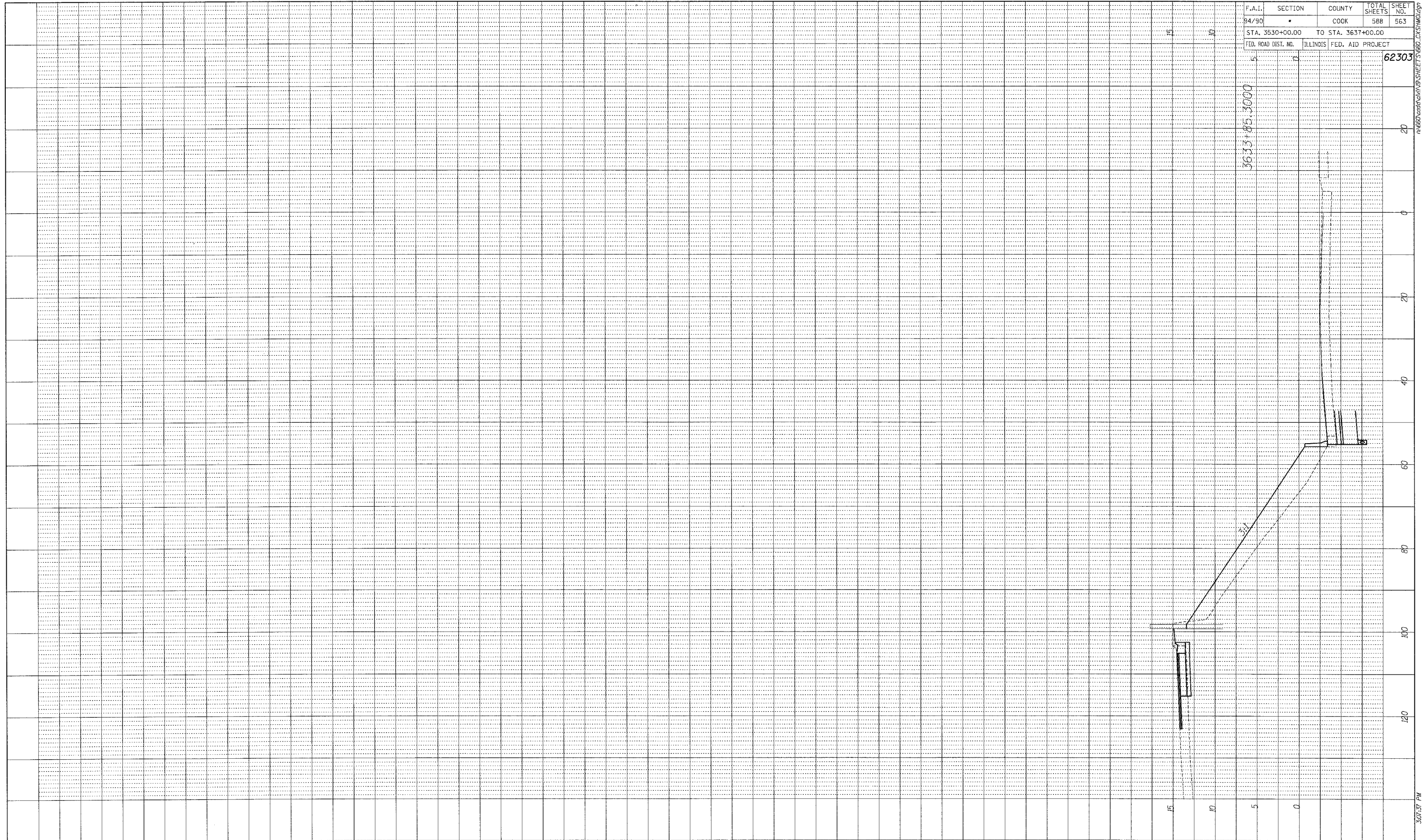

BOWMAN, BARRETT & ASSOCIATES INC
 CONSULTING ENGINEERS
 Chicago, Illinois
 312.228.0100
 www.bbainc.com

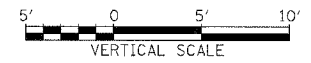

F.A.I. RTE.	SECTION	COUNTY	TOTAL SHEETS	SHEET NO.
90/94		COOK	588	565
FED. ROAD DIST. NO. 1 ILLINOIS FED. AID PROJECT				
62303 • (2021-922 PT2 ETC 2324.6-1P) R-10				

FINAL SURVEY	DATE
NO. _____	BY _____
DATE _____	BY _____
NO. _____	BY _____
DATE _____	BY _____
NO. _____	BY _____

ORIGINAL SURVEY	DATE
NO. _____	BY _____
DATE _____	BY _____
NO. _____	BY _____
DATE _____	BY _____
NO. _____	BY _____

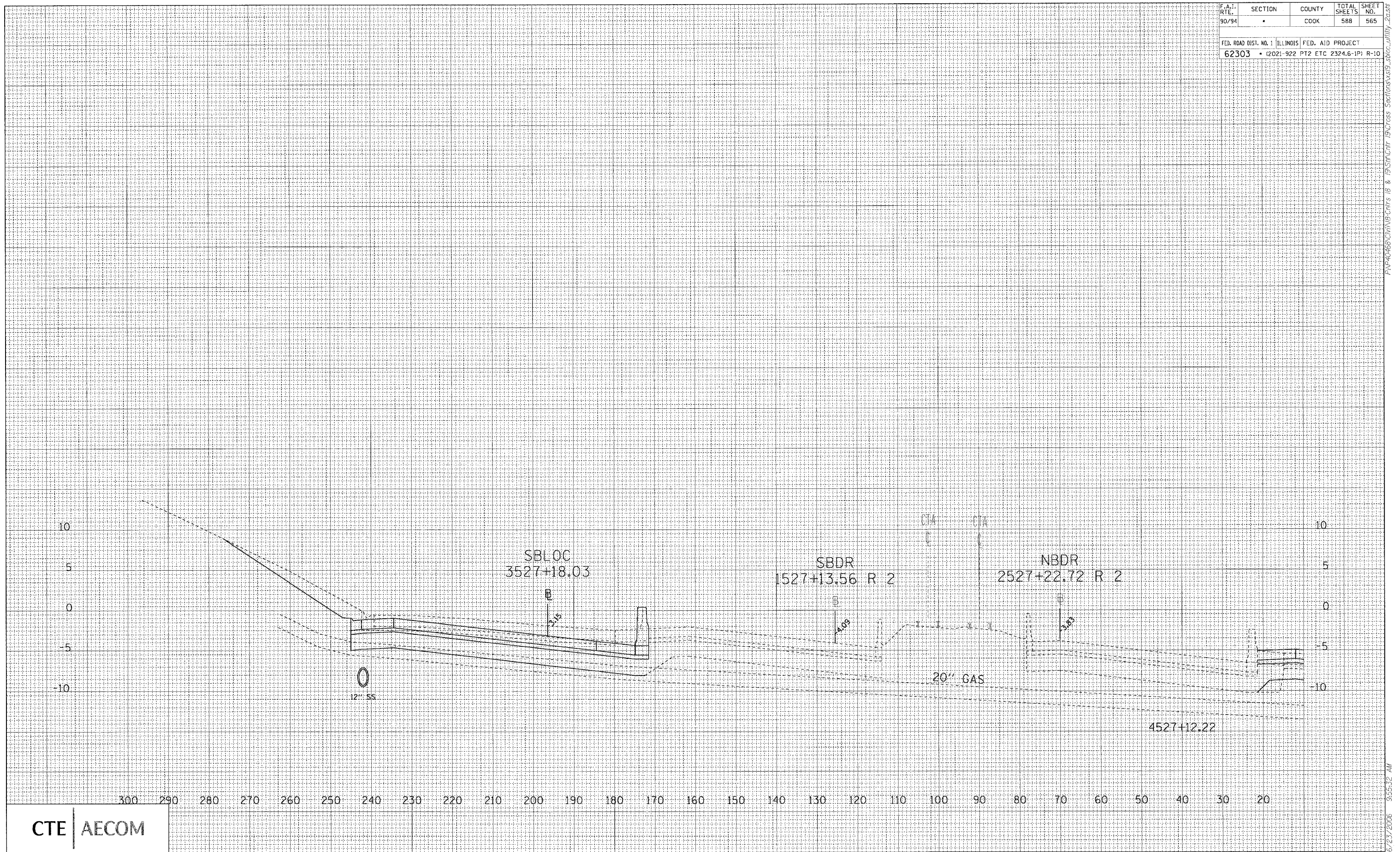

CTE | AECOM

FN-40166-Civil-IB & 1935M-Cat-19-Cross-Sections-v819-Subc-Utility-24.st 9:55:32 AM 6/27/2006

F.A.I. RITE	SECTION	COUNTY	TOTAL SHEETS	SHEET NO.
94/90		COOK	588	568

FED. ROAD DIST. NO. 1 ILLINOIS FED. AID PROJECT
 • (2021-922 PT2 ETC 2324.6-1P)R-11

DATE	BY

FINAL SURVEY SURVEYED
 PLOTTED
 NOTE BOOK
 NO. AREAS CHECKED

DATE	BY

ORIGINAL SURVEY SURVEYED
 PLOTTED
 NOTE BOOK
 NO. AREAS CHECKED

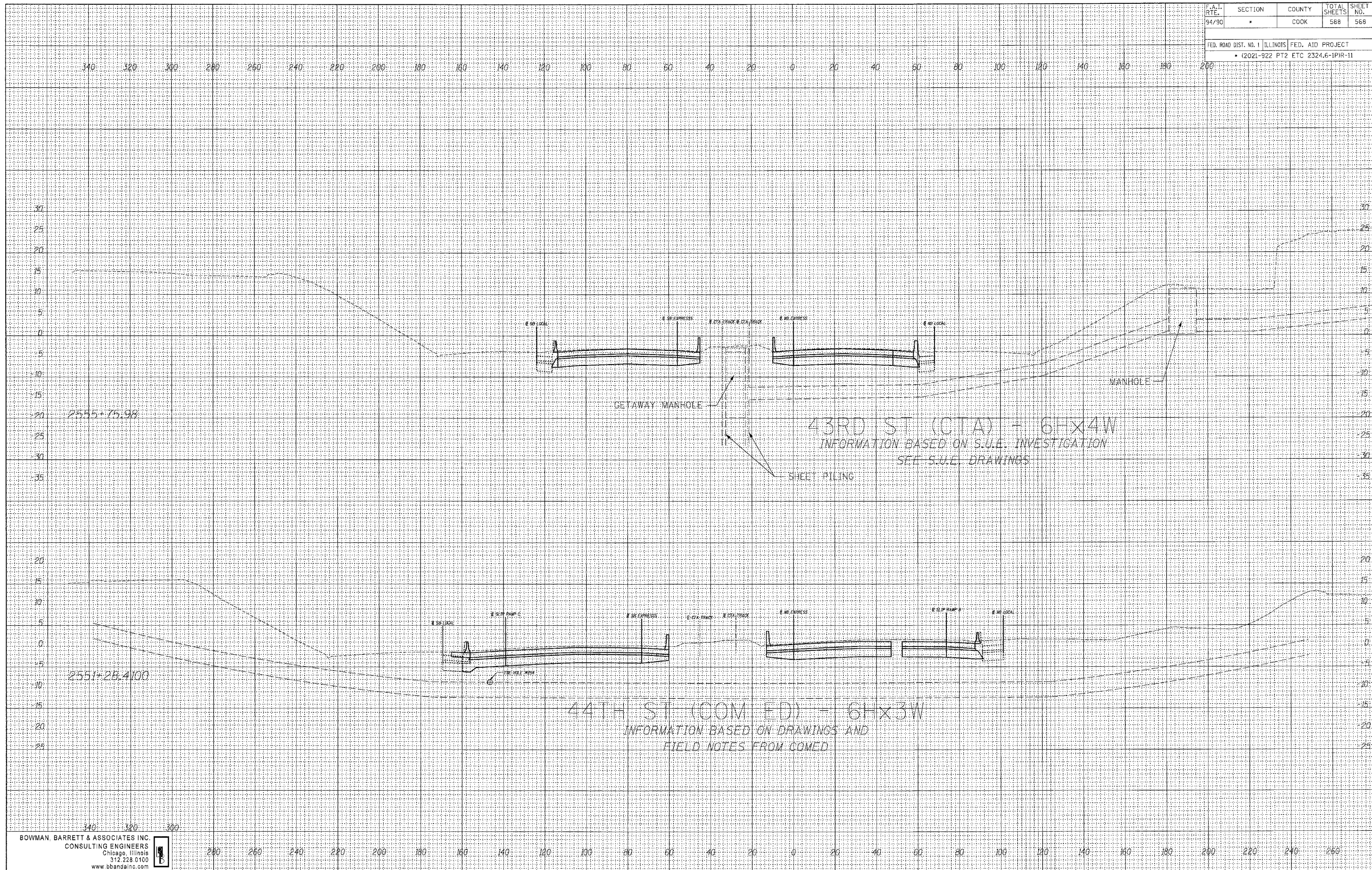

6/8/2006 2:44:58 PM

F.A.I. DIST.	SECTION	COUNTY	TOTAL SHEETS	SHEET NO.
94/90		COOK	588	569

FED. ROAD DIST. NO. 1 ILLINOIS FED. AID PROJECT
 (2021-922 PT2 ETC 2324.6-1PR-11)

DATE	BY
ORIGINAL SURVEY	SURVEYED
NOTE BOOK NO.	PLOTTED
	DATE
	AREAS
	CHECKED

DATE	BY
ORIGINAL SURVEY	SURVEYED
NOTE BOOK NO.	PLOTTED
	DATE
	AREAS
	CHECKED

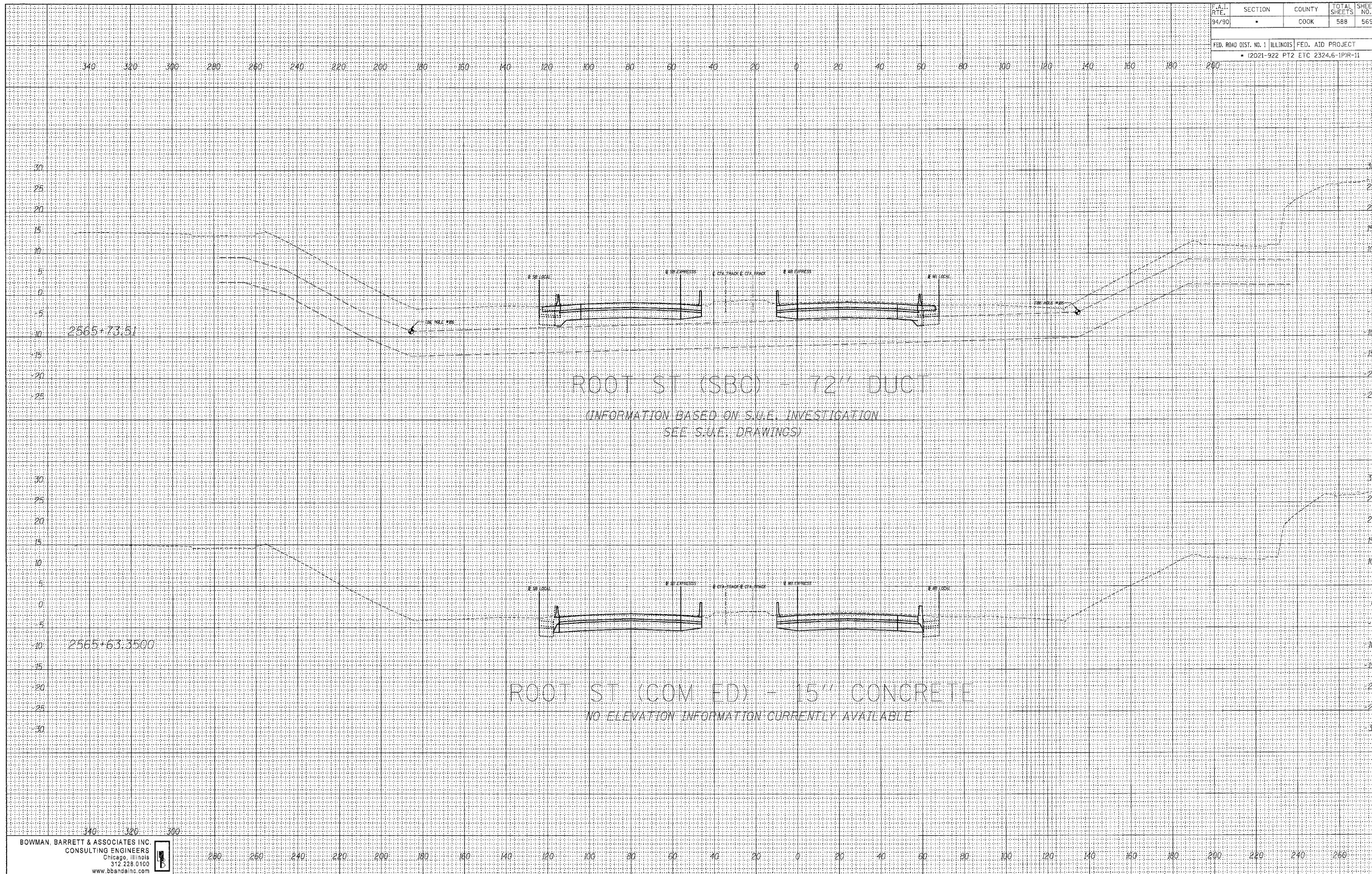

6/8/2006 2:45:00 PM

F.A.I. RTE.	SECTION	COUNTY	TOTAL SHEETS	SHEET NO.
94/90	•	COOK	588	570
FED. ROAD DIST. NO. 1		ILLINOIS	FED. AID PROJECT	
		• (2021-922 PT2 ETC 2324.6-1)PR-11		

DATE	BY
SURVEYED	PLOTTED
NOTE BOOK	AREAS CHECKED
NO.	

DATE	BY
ORIGINAL SURVEY	PLOTTED
NOTE BOOK	AREAS CHECKED
NO.	

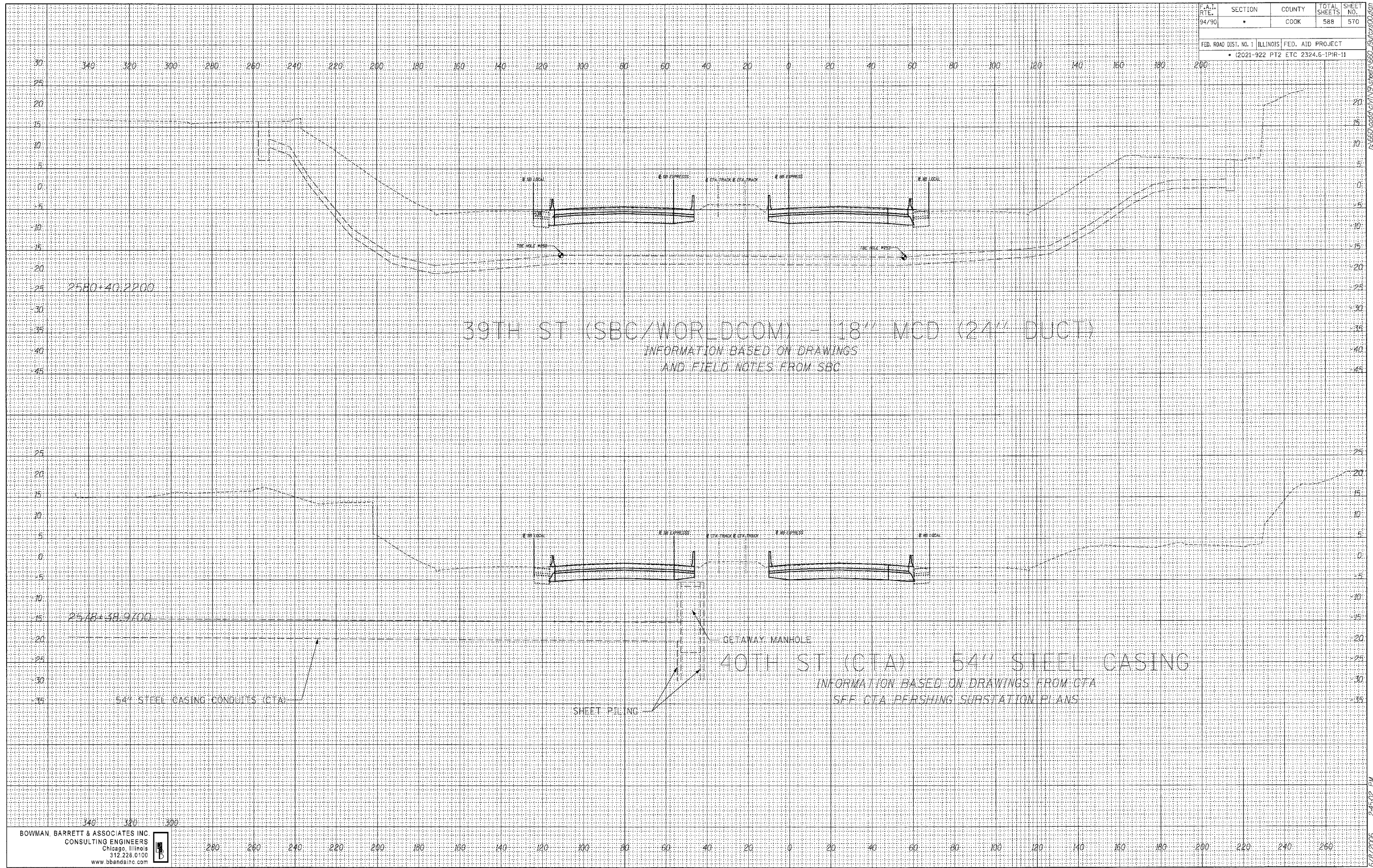

F.A.I. RTE.	SECTION	COUNTY	TOTAL SHEETS	SHEET NO.
94/90	•	COOK	588	572
FED. ROAD DIST. NO. 1 ILLINOIS FED. AID PROJECT				
• (2021-922 PT2 ETC 2324.6-1PR-11				

DATE	BY

FINAL SURVEY	SURVEYED
NOTE BOOK	PLOTTED
NO.	AREAS CHECKED

DATE	BY

ORIGINAL SURVEY	SURVEYED
NOTE BOOK	PLOTTED
NO.	AREAS CHECKED

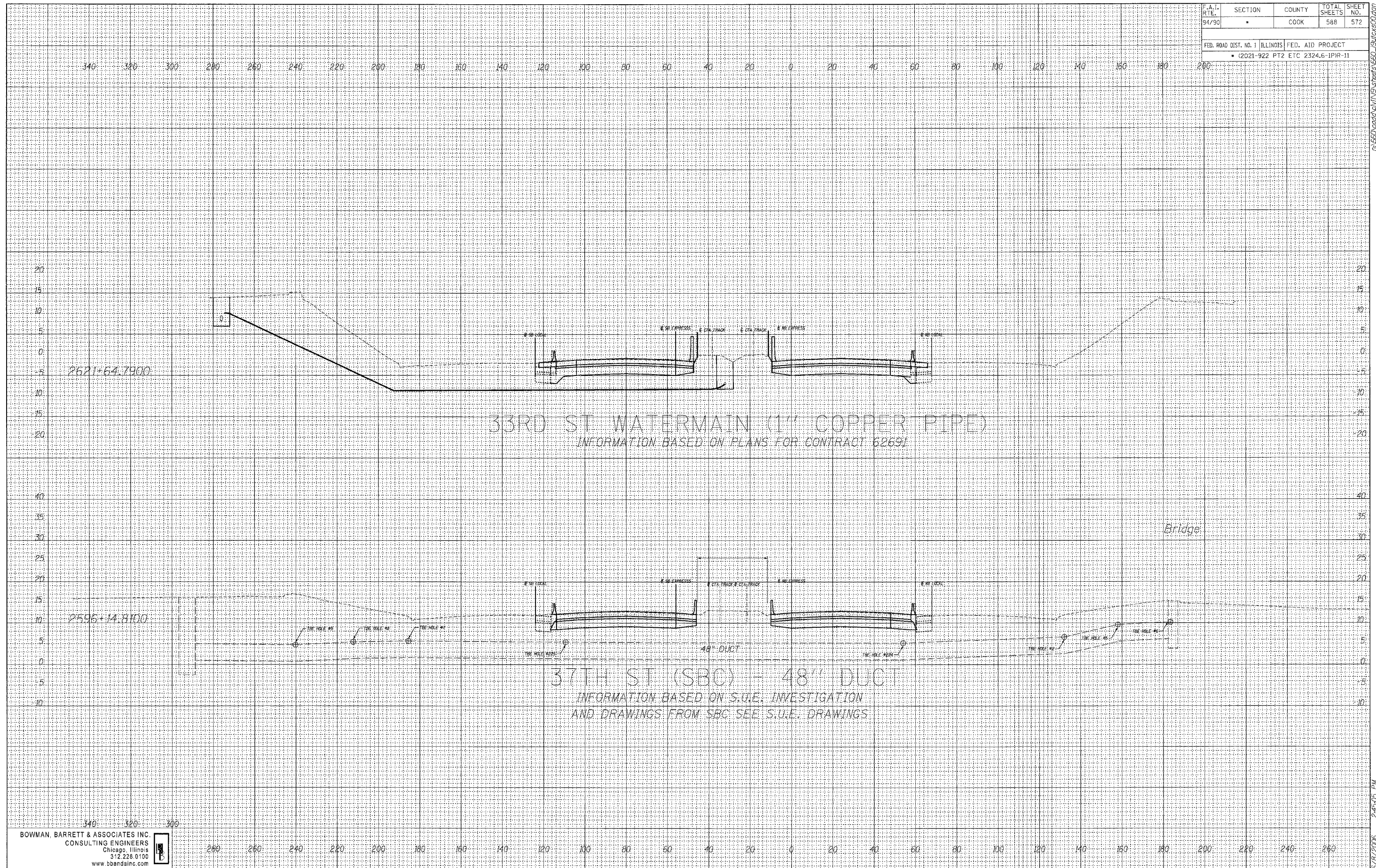

17-660-0000-01/19 Streets 660-19/00-0000-01
 6/8/2006 2:45:05 PM

F.A.J. RTE.	SECTION	COUNTY	TOTAL SHEETS	SHEET NO.
94	*	COOK		575
STA.		TO STA.		
FED. ROAD DIST. NO.		ILLINOIS FED. AID PROJECT		
* - PENDING I.D.O.T. PROGRAMMING				



PLAN	DATE
DATE	BY
REVISIONS	
NO.	DESCRIPTION
1	AS SHOWN

PROFILE	DATE
DATE	BY
REVISIONS	
NO.	DESCRIPTION
1	AS SHOWN

P:\1\0468\civil\02-dc\sh1\scoll\proj\file\468exh05.jl.sht
 11/2/2005

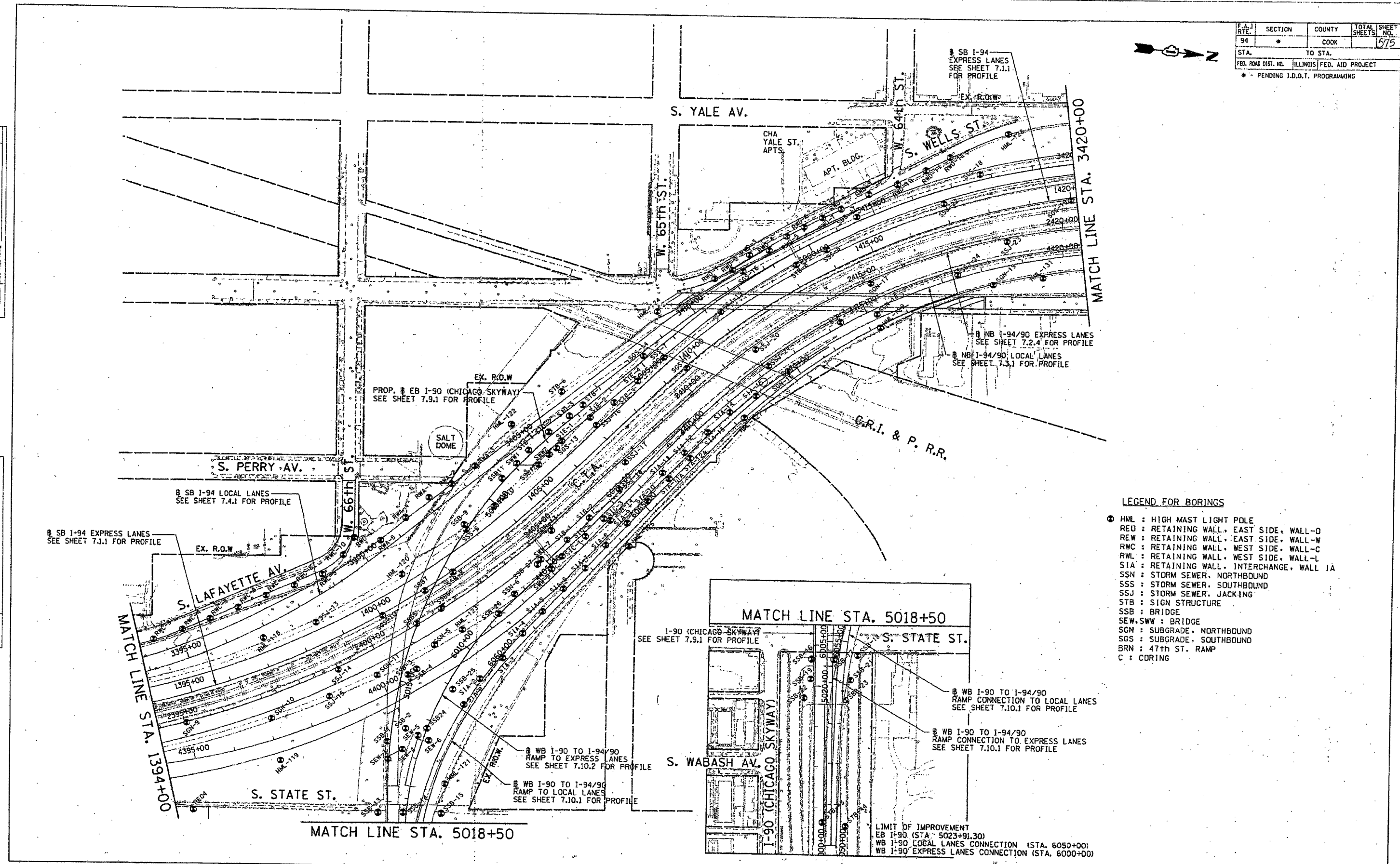

- LEGEND FOR BORINGS**
- ⊙ HML : HIGH MAST LIGHT POLE
 - RED : RETAINING WALL, EAST SIDE, WALL-O
 - REW : RETAINING WALL, EAST SIDE, WALL-W
 - RWC : RETAINING WALL, WEST SIDE, WALL-C
 - RWL : RETAINING WALL, WEST SIDE, WALL-L
 - SIA : RETAINING WALL, INTERCHANGE, WALL IA
 - SSN : STORM SEWER, NORTHBOUND
 - SSS : STORM SEWER, SOUTHBOUND
 - SSJ : STORM SEWER, JACKING
 - STB : SIGN STRUCTURE
 - SSB : BRIDGE
 - SEW.SWW : BRIDGE
 - SGN : SUBGRADE, NORTHBOUND
 - SGS : SUBGRADE, SOUTHBOUND
 - BRN : 47th ST. RAMP
 - C : CORING

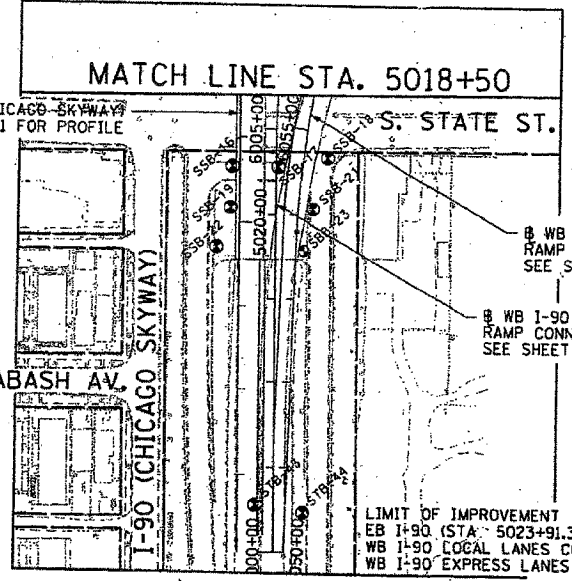

CTE 40256

DAN RYAN AND SKYWAY INTERCHANGE PLAN

1"=100'

EXHIBIT NO. 5.11

F.A.J. RFE. 94	SECTION *	COUNTY COOK	TOTAL SHEETS 576	SHEET NO. 576
STA. TO STA.		FED. ROAD DIST. NO. ILLINOIS FED. AID PROJECT		
* - PENDING I.D.O.T. PROGRAMMING				

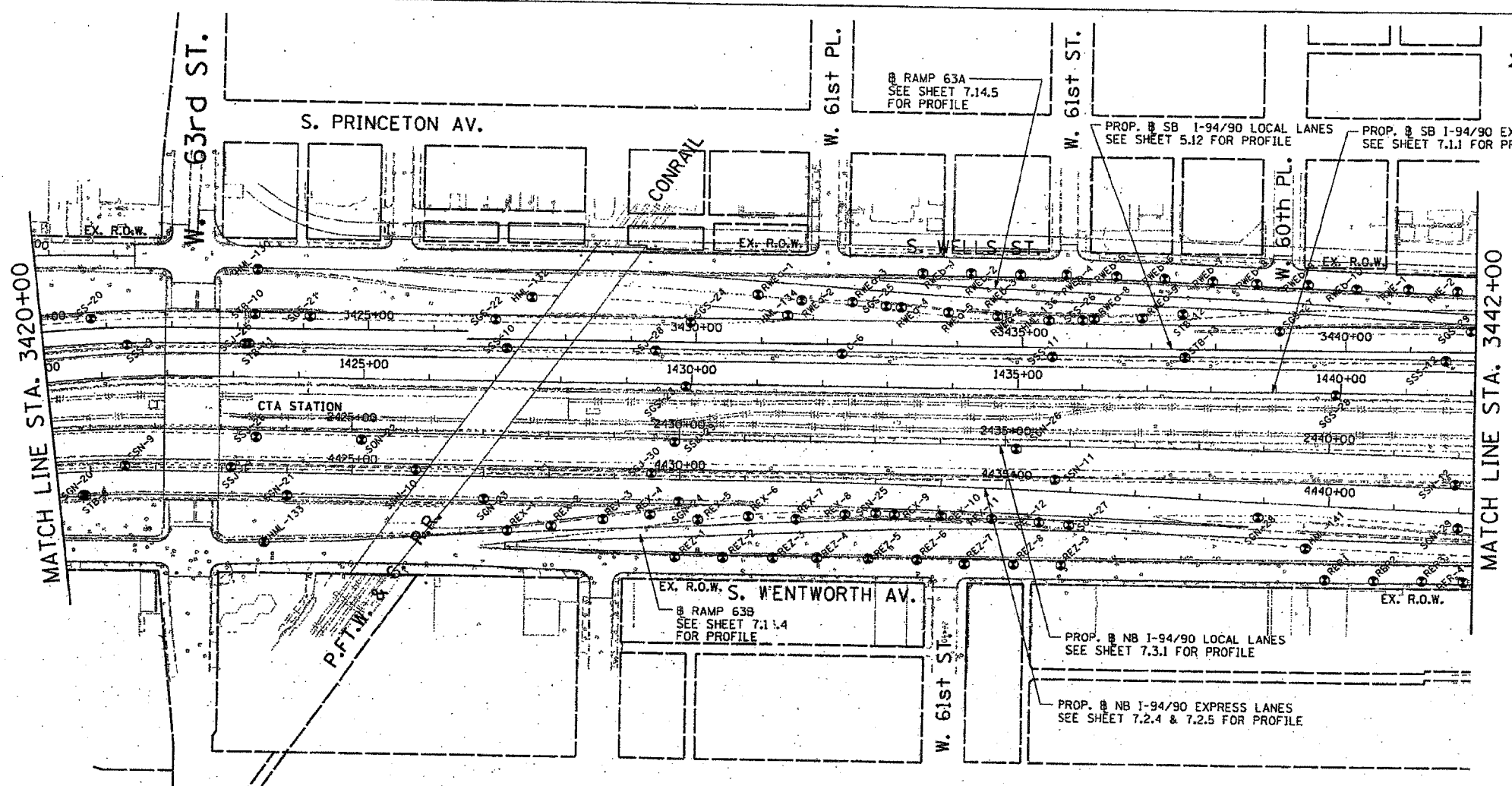

- LEGEND FOR BORINGS**
- ⊙ HML : HIGH MAST LIGHT POLE
 - ⊙ RED : RETAINING WALL, EAST SIDE, WALL-O
 - ⊙ REW : RETAINING WALL, EAST SIDE, WALL-W
 - ⊙ RWC : RETAINING WALL, WEST SIDE, WALL-C
 - ⊙ RWL : RETAINING WALL, WEST SIDE, WALL-L
 - ⊙ SIA : RETAINING WALL, INTERCHANGE, WALL IA
 - ⊙ SSN : STORM SEWER, NORTHBOUND
 - ⊙ SSS : STORM SEWER, SOUTHBOUND
 - ⊙ SSJ : STORM SEWER, JACKING
 - ⊙ STB : SIGN STRUCTURE
 - ⊙ SSB : BRIDGE
 - ⊙ SEW.SWW : BRIDGE
 - ⊙ SGN : SUBGRADE, NORTHBOUND
 - ⊙ SGS : SUBGRADE, SOUTHBOUND
 - ⊙ BRN : 47th ST. RAMP
 - ⊙ C : CORING

DATE	BY	REVISION

DATE	BY	REVISION

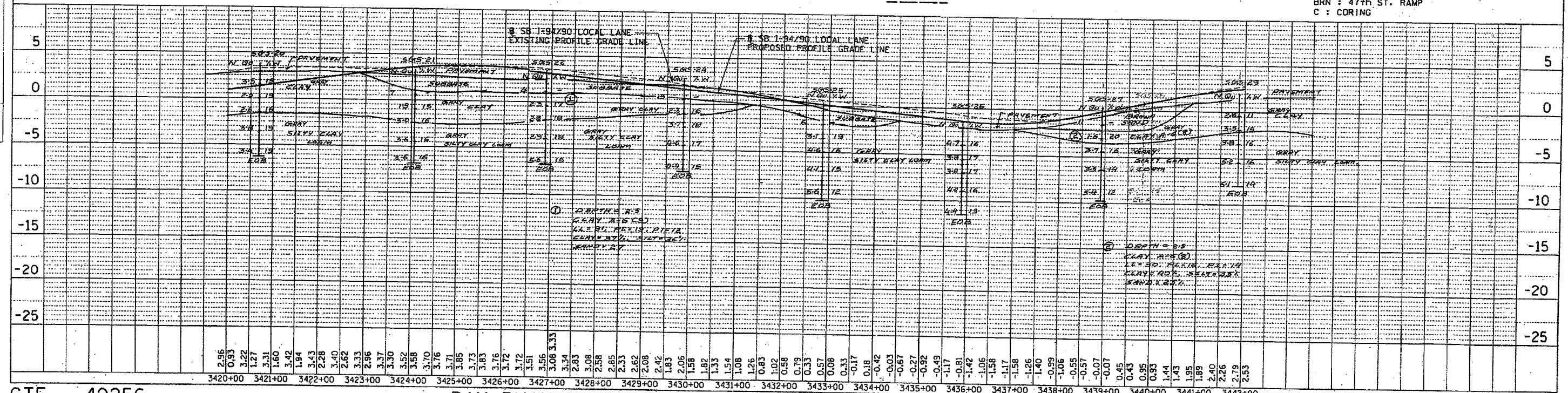

CTE 40256 DAN RYAN PLAN AND SB I-94/90 LOCAL LANES PROFILE SCALE: HORIZ. 1"=100' VERT. 1"=5' EXHIBIT NO. 5.12

P:\D\10456\CIVIL\02-dc\shh\soil\profile_4686xh05_02.dnt
 11/12/2003

F.A.I. RTE.	SECTION	COUNTY	TOTAL SHEETS	SHEET NO.
94	*	COOK		579
STA.	TO STA.			
FED. ROAD DIST. NO. ILLINOIS FED. AID PROJECT				
* - PENDING I.D.O.T. PROGRAMMING				

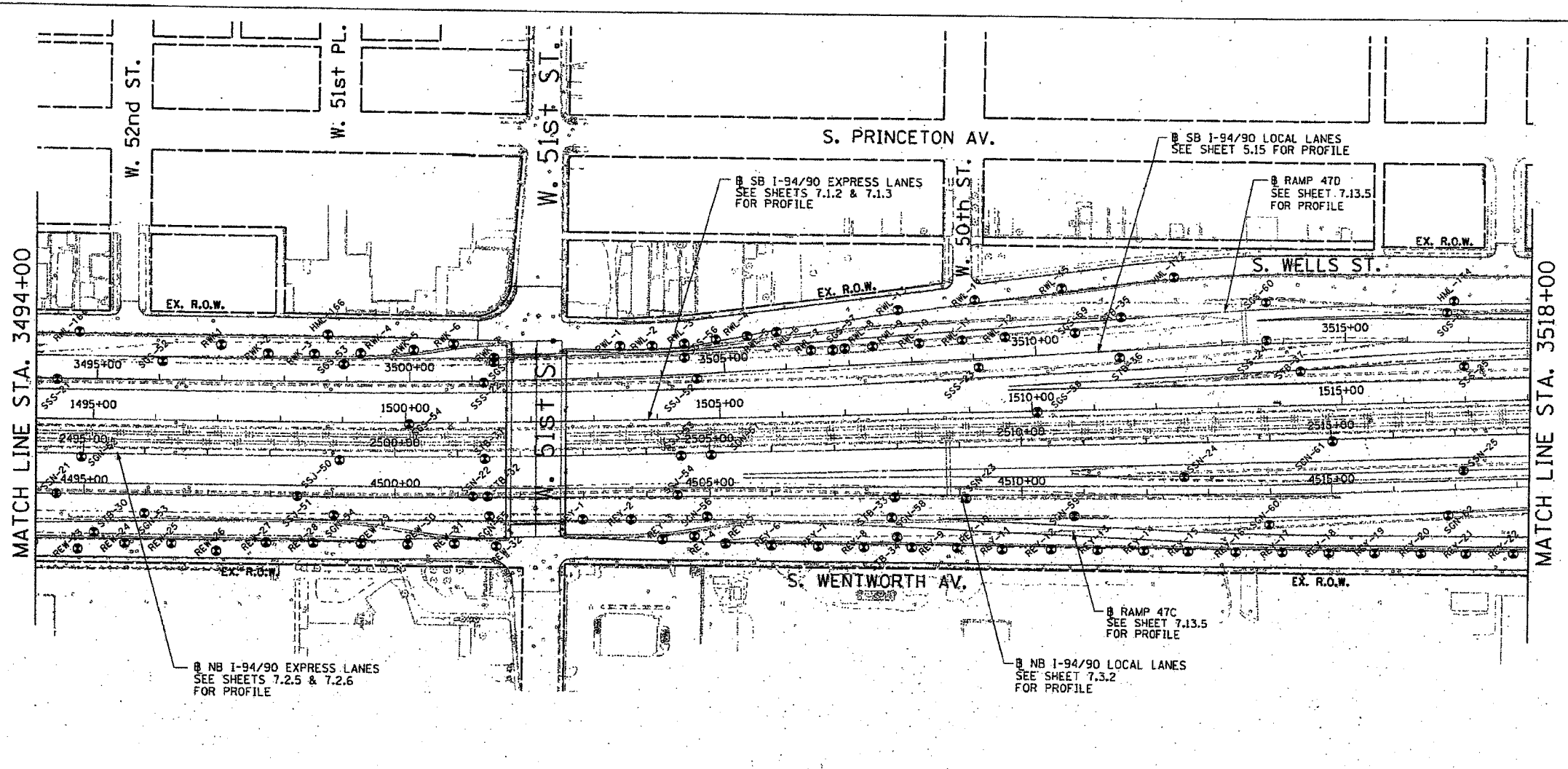

- LEGEND FOR BORINGS**
- ⊙ HML : HIGH MAST LIGHT POLE
 - ⊠ RED : RETAINING WALL, EAST SIDE, WALL-D
 - ⊠ REW : RETAINING WALL, EAST SIDE, WALL-W
 - ⊠ RWC : RETAINING WALL, WEST SIDE, WALL-C
 - ⊠ RWL : RETAINING WALL, WEST SIDE, WALL-L
 - ⊠ STA : RETAINING WALL, INTERCHANGE, WALL 1A
 - ⊠ SSN : STORM SEWER, NORTHBOUND
 - ⊠ SSS : STORM SEWER, SOUTHBOUND
 - ⊠ SSJ : STORM SEWER, JACKING
 - ⊠ STB : SIGN STRUCTURE
 - ⊠ SSB : BRIDGE
 - ⊠ SEW.SWW : BRIDGE
 - ⊠ SGN : SUBGRADE, NORTHBOUND
 - ⊠ SGS : SUBGRADE, SOUTHBOUND
 - ⊠ BRN : 47th ST. RAMP
 - ⊠ C : CORING

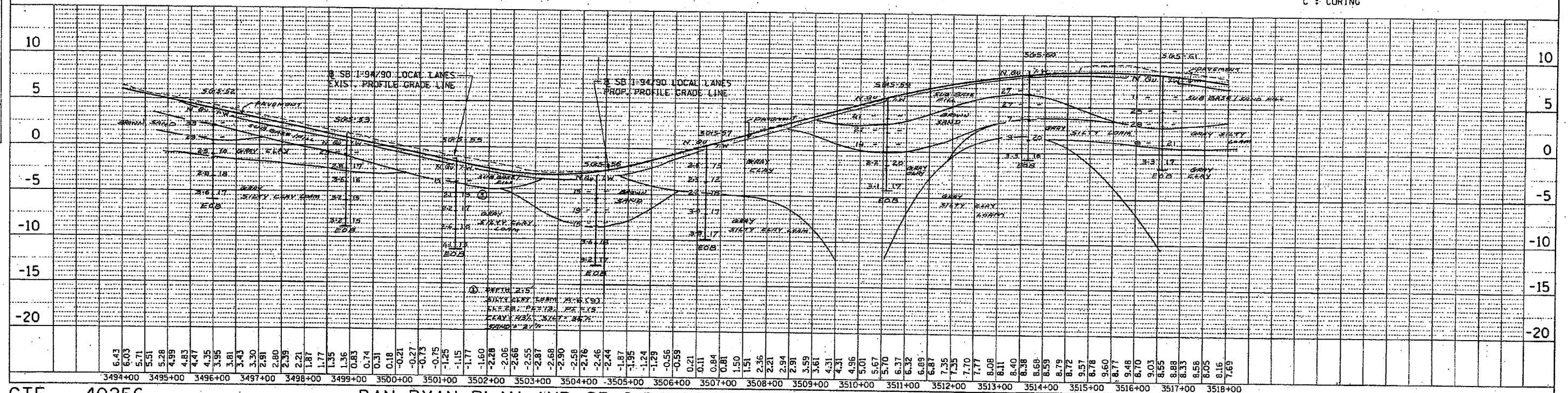

CTE 40256 DAN RYAN PLAN AND SB I-94/90 LOCAL LANES PROFILE SCALE: HORIZ. 1"=100' VERT. 1"=5' EXHIBIT NO. 5.15

DATE	BY

DATE	BY

D:\40468\civ\102-dc\sh\1\soil\pr\profile_468exh05_15.shx
11/27/2003

F.A.I. RT. NO.	SECTION	COUNTY	TOTAL SHEETS	SHEET NO.
94	*	COOK	581	581
STA. TO STA.		FED. ROAD DIST. NO. ILLINOIS FED. AID PROJECT		
4391+00 TO 4452+00		* - PENDING I.D.O.T. PROGRAMMING		

PLAN	DATE
BY	
NO.	

PROFILE	DATE
BY	
NO.	

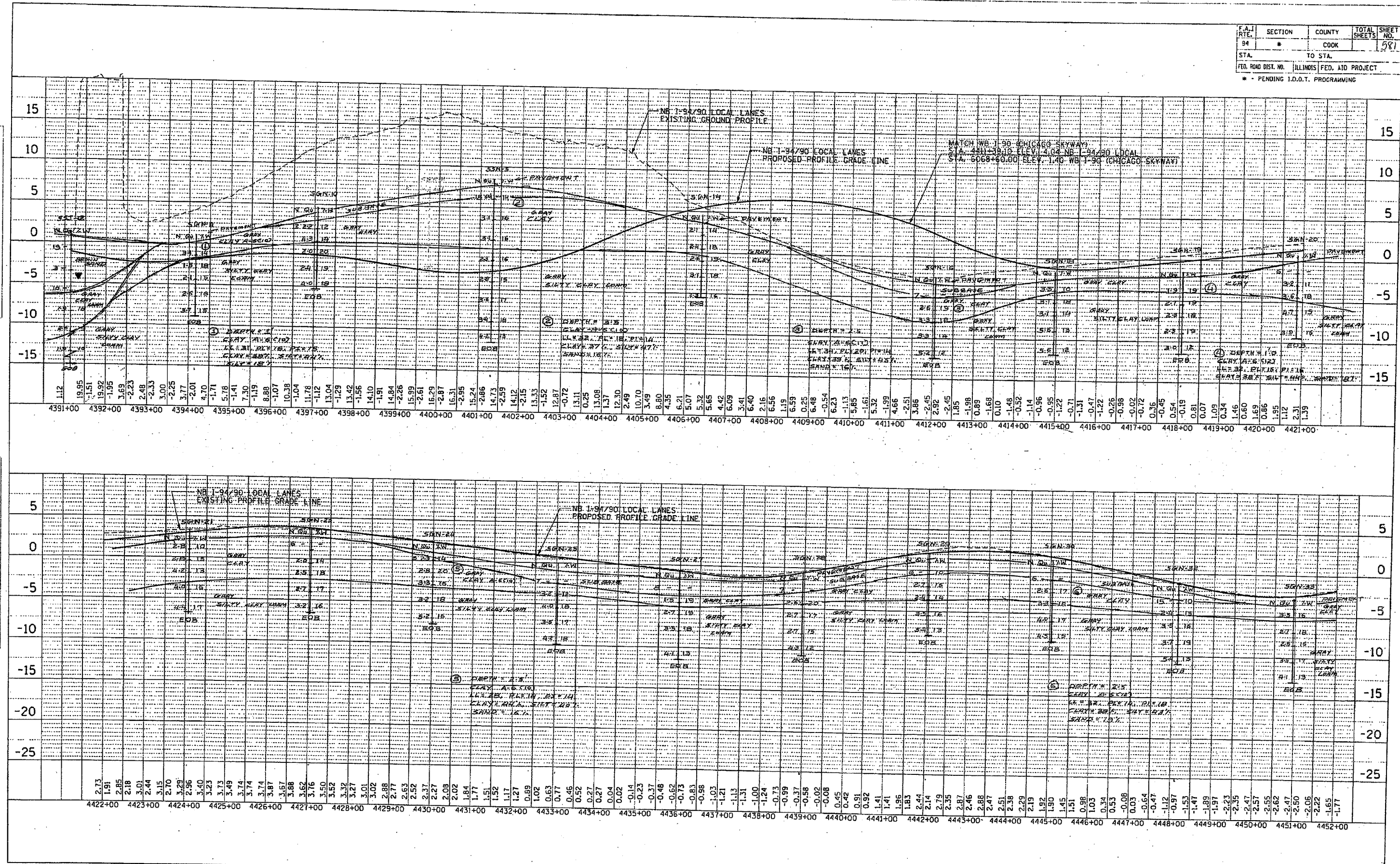

CTE 40256 NB I-94 AND I-94/90 LOCAL LANES PROFILE (STA. 4392+00 TO STA. 4452+00) SCALE: HORIZ. 1"=100' VERT. 1"=5' EXHIBIT NO. 7.3.1

ms:\p40468\civil\02-dc_sht\soil\profile\468exh07_03_01.sht
11/2/2003

PLAN
 DRAWN BY: []
 CHECKED BY: []
 DATE: []

PROFILE
 DRAWN BY: []
 CHECKED BY: []
 DATE: []

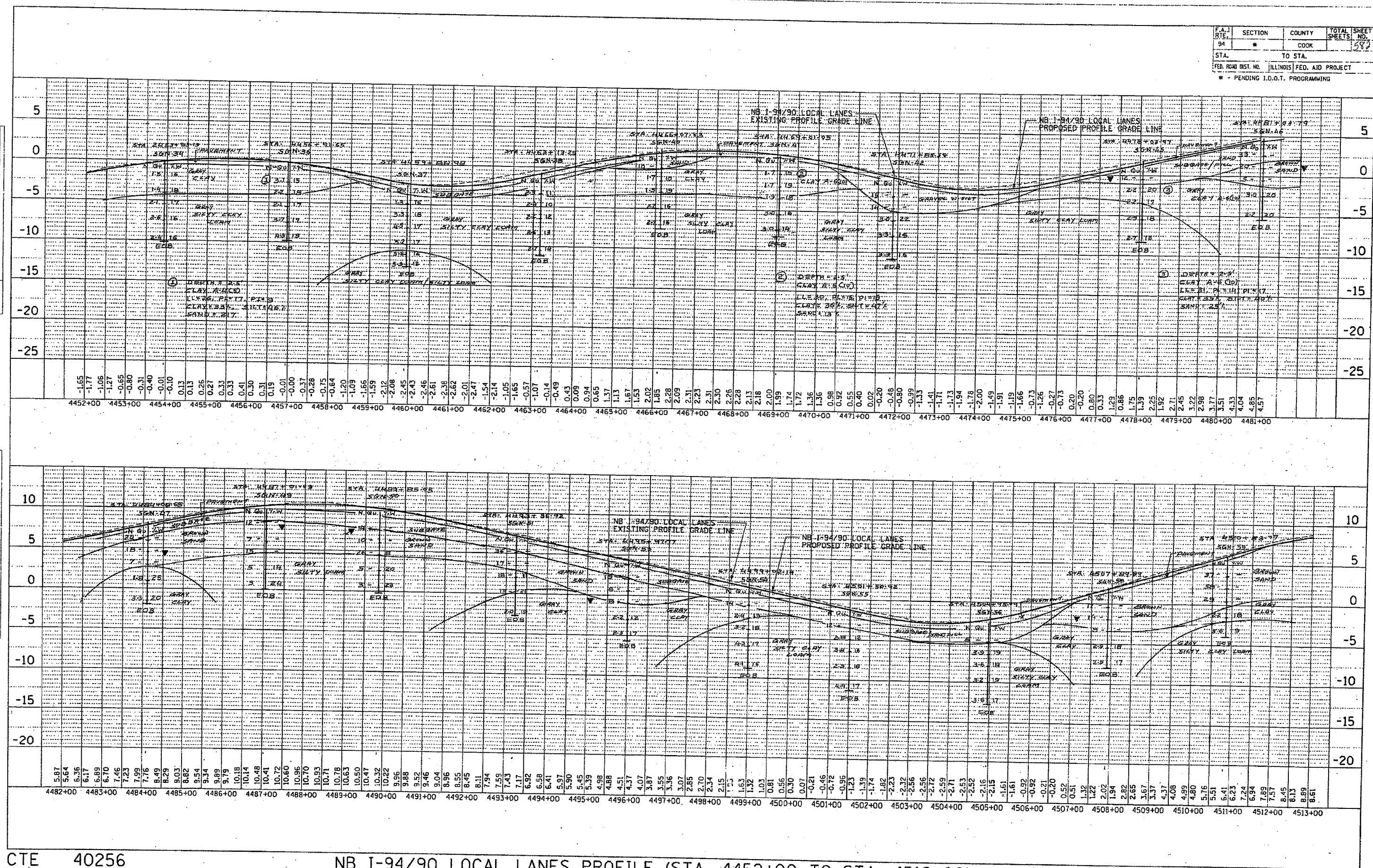

m:\p40468\civil\02-dc\shh\soil\profile\468exh07_03_02.sht
 11/27/2003

F.A. RTE.	SECTION	COUNTY	TOTAL SHEETS	SHEET NO.
94	*	COOK		584
STA.		TO STA.		
FED. ROAD DIST. NO.		ILLINOIS	FED. AID PROJECT	
* - PENDING I.D.O.T. PROGRAMMING				

DATE	BY
DATE	BY

DATE	BY
DATE	BY

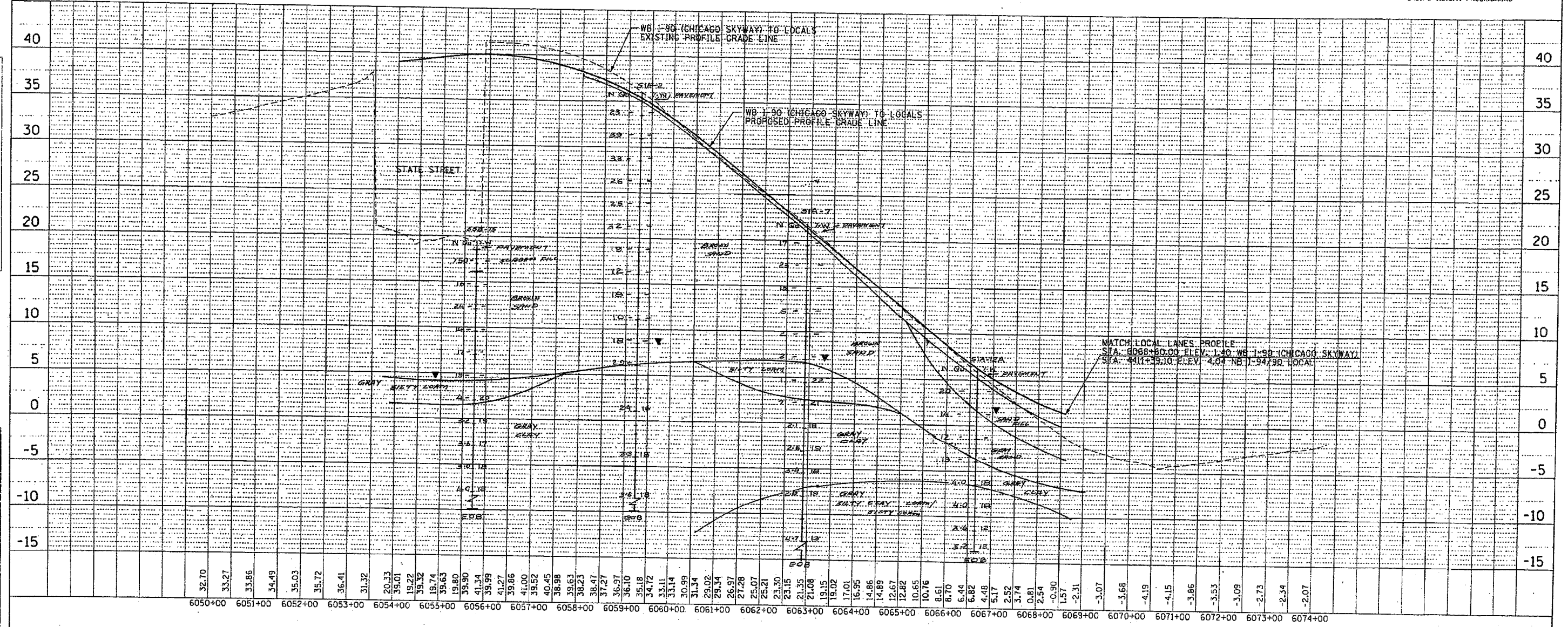

6050+00	32.70	6051+00	33.27	6052+00	33.86	6053+00	34.49	6054+00	35.03	6055+00	35.72	6056+00	36.41	6057+00	31.32	6058+00	20.33	6059+00	19.01	6060+00	19.22	6061+00	19.74	6062+00	19.80	6063+00	19.80	6064+00	41.34	6065+00	39.99	6066+00	41.27	6067+00	39.86	6068+00	41.00	6069+00	39.52	6070+00	40.45	6071+00	38.98	6072+00	39.63	6073+00	38.23	6074+00	38.47	37.27	36.97	36.10	35.18	34.72	33.11	33.14	30.99	31.34	29.02	29.34	26.97	27.28	25.07	25.21	23.50	23.15	21.35	21.08	19.15	19.02	17.01	16.95	14.86	14.89	12.67	12.82	10.65	10.76	8.61	8.70	6.44	6.82	4.48	5.17	2.52	3.74	0.81	2.34	-0.90	1.57	-2.31	-3.07	-3.68	-4.19	-4.15	-3.86	-3.53	-3.09	-2.73	-2.34	-2.07
---------	-------	---------	-------	---------	-------	---------	-------	---------	-------	---------	-------	---------	-------	---------	-------	---------	-------	---------	-------	---------	-------	---------	-------	---------	-------	---------	-------	---------	-------	---------	-------	---------	-------	---------	-------	---------	-------	---------	-------	---------	-------	---------	-------	---------	-------	---------	-------	---------	-------	-------	-------	-------	-------	-------	-------	-------	-------	-------	-------	-------	-------	-------	-------	-------	-------	-------	-------	-------	-------	-------	-------	-------	-------	-------	-------	-------	-------	-------	------	------	------	------	------	------	------	------	------	------	-------	------	-------	-------	-------	-------	-------	-------	-------	-------	-------	-------	-------

CTE 40256

WB I-90 TO I-94/90 RAMP CONNECTION TO LOCAL LANES PROFILE

SCALE: HORIZ. 1"=100'
VERT. 1"=5'

EXHIBIT NO. 7.10.1

m:\p0468\civil\02-dc\shh\soil\profile\486xh07_10_01.sht 11/2/2003

F.A.I. RITE.	SECTION	COUNTY	TOTAL SHEETS	SHEET NO.
94	*	COOK	98	98
STA.	TO STA.			
FED. ROAD DIST. NO.	ILLINOIS FED. AID PROJECT			
* - PENDING I.D.O.T. PROGRAMMING				

PLAN	DATE
BY	
REVISION	
NO.	

PROFILE	DATE
BY	
REVISION	
NO.	

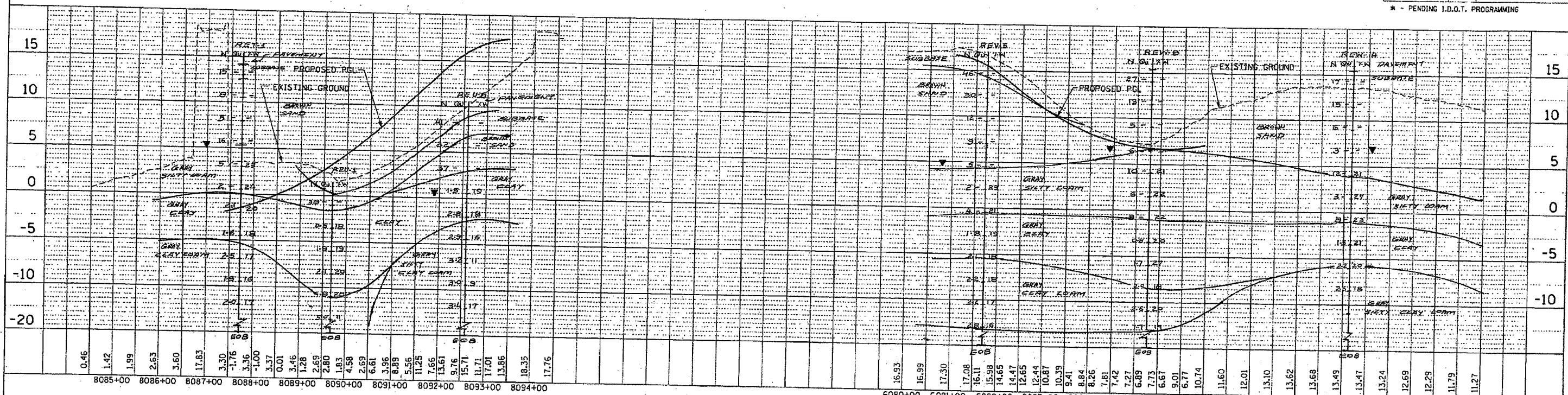

RAMP 55C - NB EXIT RAMP TO 55TH STREET

RAMP 55B - NB ENTRANCE RAMP FROM 55TH STREET

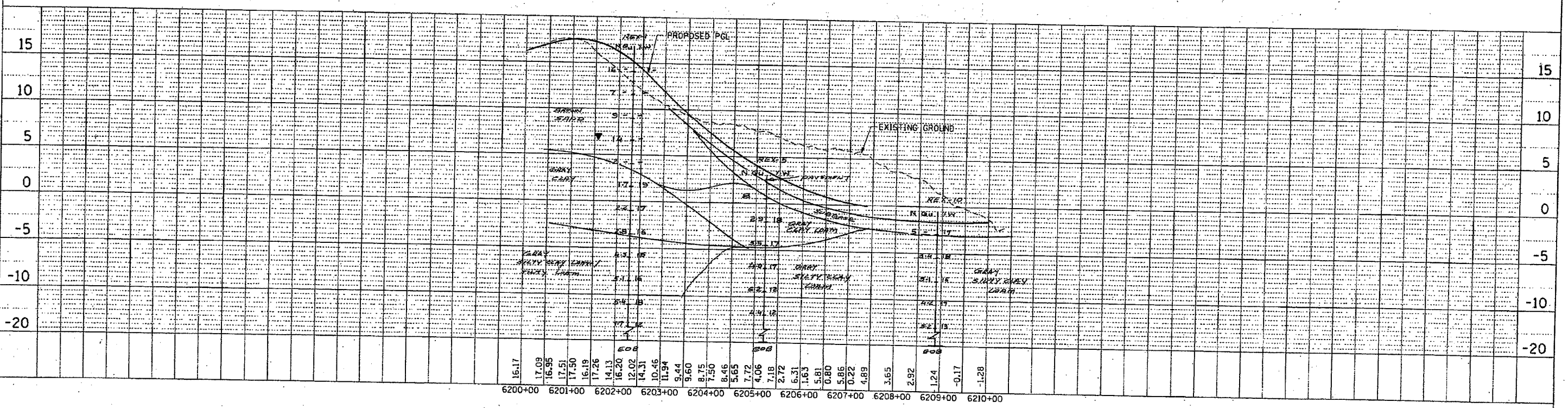

RAMP 63B - NB ENTRANCE RAMP FROM 63RD STREET

NB RAMP PROFILES

CTE 40256

SCALE: HORIZ. 1"=100'
VERT. 1"=5'
EXHIBIT NO. 7.13.4

m:\p40468\civil\02-dc\shf\soil\profile\468exh07.13.04.shp
1/12/2003

F.A. RTE.	SECTION	COUNTY	TOTAL SHEETS	SHEET NO.
94	*	COOK	158	158
STA.	TO STA.			
FED. ROAD DIST. NO. ILLINOIS FED. AID PROJECT				
* - PENDING I.D.O.T. PROGRAMMING				

PLAN
 DRAWN BY: []
 CHECKED BY: []
 DATE: []

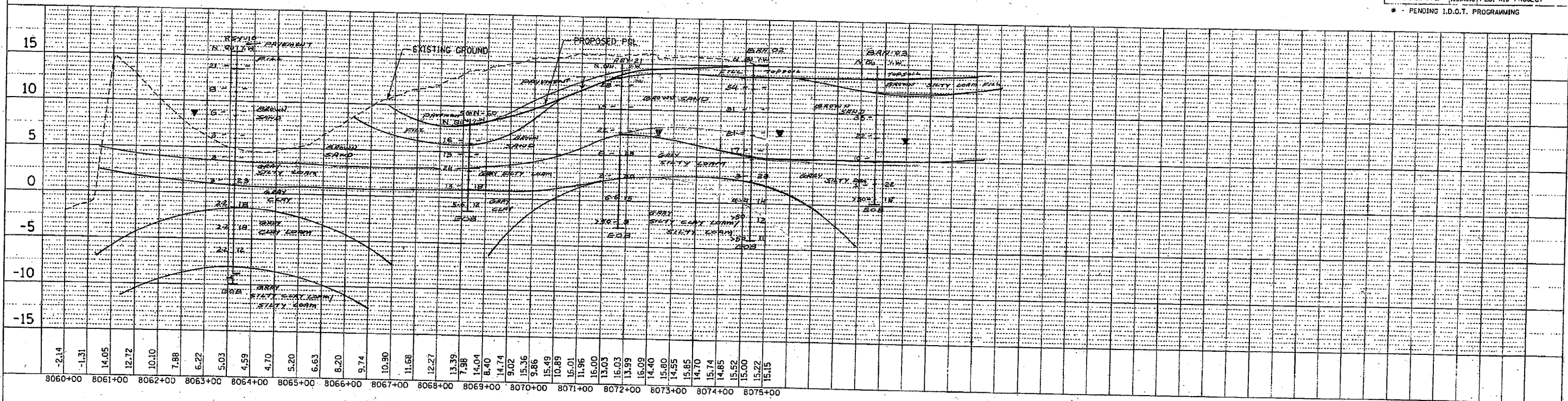

RAMP 47C - NB EXIT TO 47TH STREET

PROFILE
 DRAWN BY: []
 CHECKED BY: []
 DATE: []

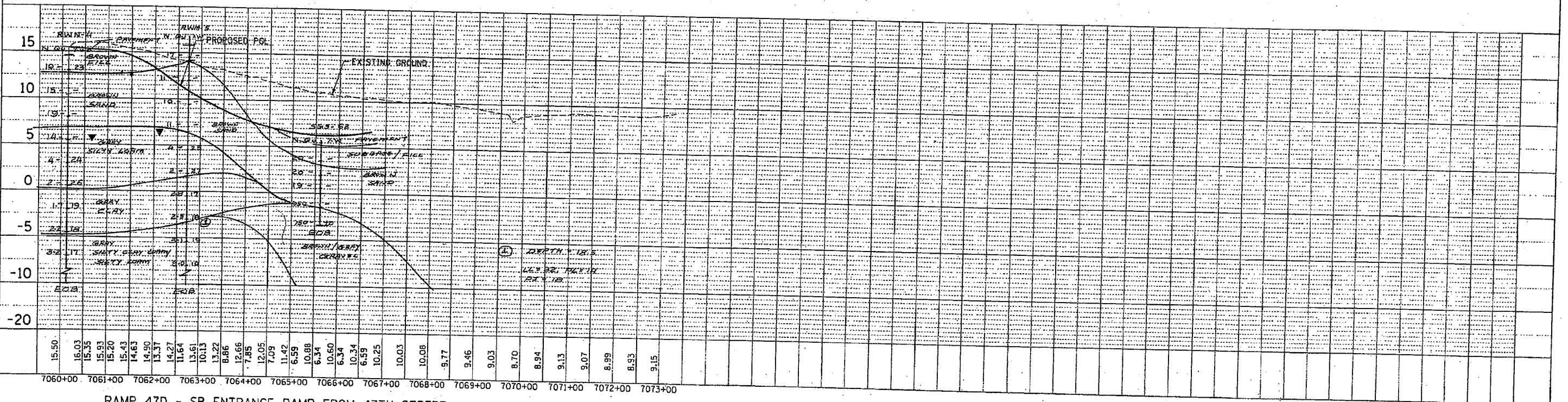

RAMP 47D - SB ENTRANCE RAMP FROM 47TH STREET

CTE 40256

NB AND SB RAMP PROFILES

SCALE: HORIZ. 1"=100'
 VERT. 1"=5'
 EXHIBIT NO. 7.13.5

m:\p40468\civil\02-dc\st\soff\p\o\file\468exh07_13_05.sht
 1/12/2003

F.A.I. RTE.	SECTION	COUNTY	TOTAL SHEETS	SHEET NO.
94	*	COCK		1588
STA.	TO STA.			
FED. ROAD DIST. NO. ILLINOIS FED. AID PROJECT				
* - PENDING I.D.O.T. PROGRAMMING				

DATE	
BY	
PROJECT	
NO.	

DATE	
BY	
PROJECT	
NO.	

