

TYPE III BARRICADE

NOTE:
MOUNTING OF ANY SIGNS ON TYPE III BARRICADES SHALL NOT BE ALLOWED.

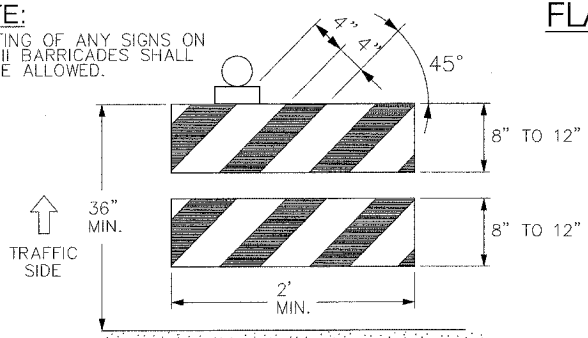

TYPE II BARRICADE

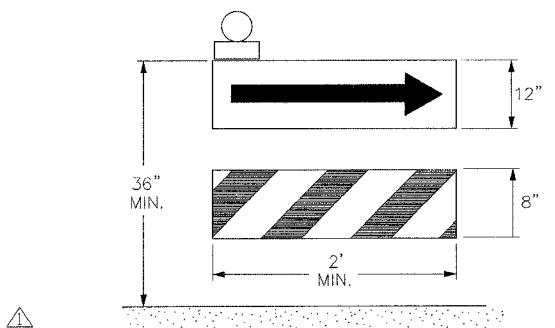

DIRECTION INDICATOR BARRICADE

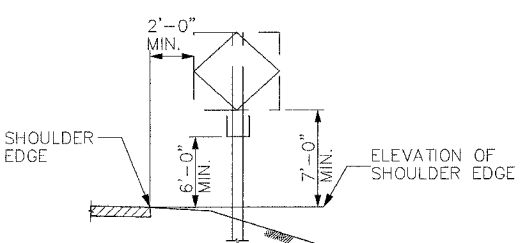

GROUND MOUNT INSTALLATION

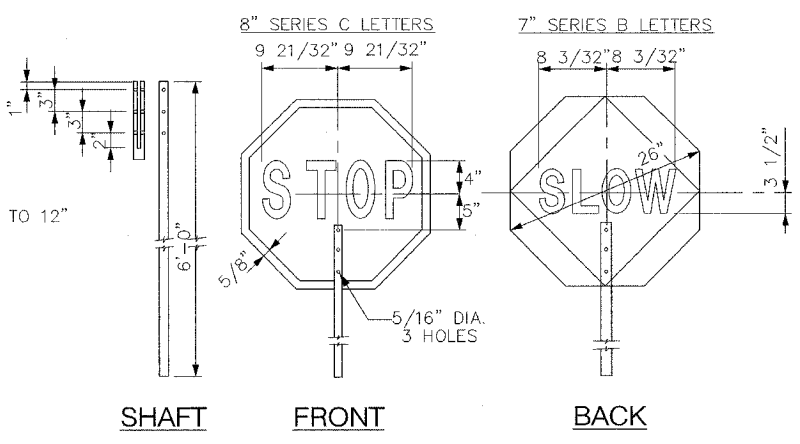

FLAGGER TRAFFIC CONTROL SIGN (PADDLE)

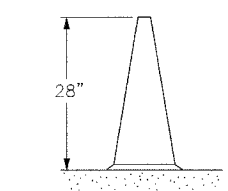

DAY TIME USE ONLY

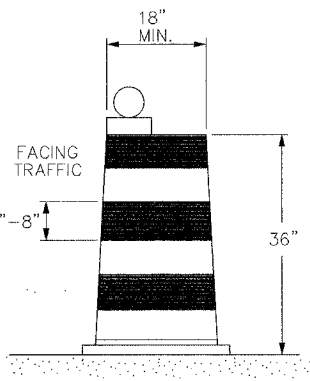

DRUM

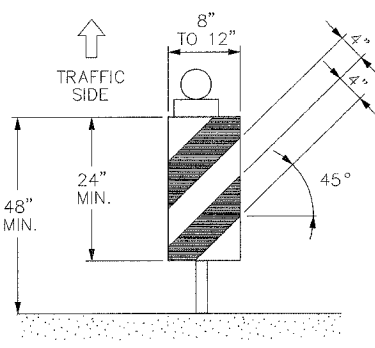

VERTICAL PANEL

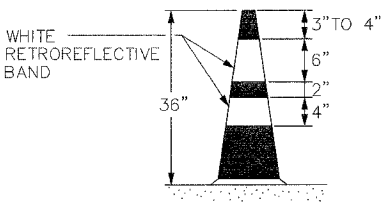

EMERGENCY NIGHT TIME USE CONES

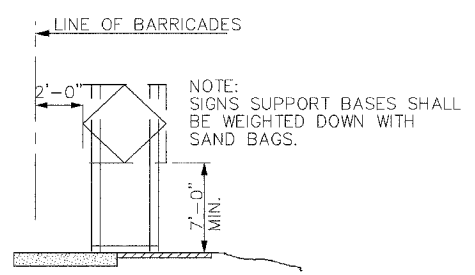

CONSTRUCTION SIGN INSTALLATION PAVEMENT OR SHOULDER MOUNT

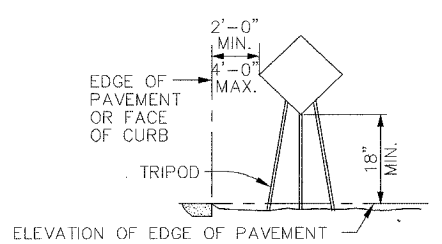

PORTABLE STAND

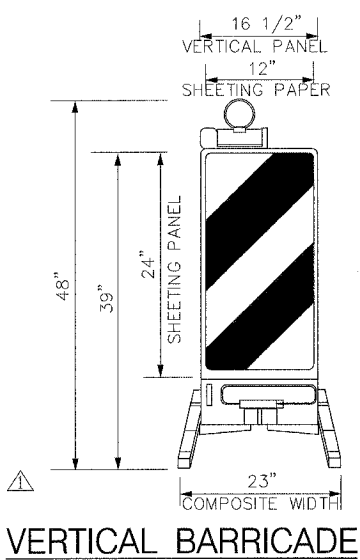

VERTICAL BARRICADE

GENERAL NOTES:

- SHEETING 1. UNLESS OTHERWISE NOTED, TYPE A REFLECTIVE SHEETING SHALL BE USED FOR TYPE II BARRICADES, DRUMS AND VERTICAL PANELS.
- USAGE 2. ONLY NON-METALLIC DRUMS OR TYPE II BARRICADES SHALL BE USED FOR LONG TERM CLOSURES. THESE DEVICES SHALL NOT BE INTERMIXED WITHIN AN INDIVIDUAL STRING OF DEVICES. CONES MAY BE USED FOR SHORT TERM CLOSURES (FROM SUNRISE TO 1 HOUR BEFORE SUNSET). VERTICAL PANELS ARE TO BE USED AS SHOWN ON THE PLANS OR DIRECTED BY THE ENGINEER. TYPE III BARRICADES ARE INTENDED FOR ROAD CLOSURES AND SHALL NOT BE USED FOR DELINEATION OR CHANNELIZATION.
- HEIGHT 3. ALL HEIGHTS SHOWN ARE MEASURED ABOVE THE PAVEMENT SURFACE. DEVICES PLACED ADJACENT TO A TRAFFIC LANE IN AN EXCAVATED AREA 6 INCHES OR DEEPER SHALL HAVE LEGS EXTENDED TO PROVIDE THE DESIRED HEIGHT ABOVE THE PAVEMENT AS SHOWN.
- STRIPING 4. ALL BARRICADES AND VERTICAL PANELS SHALL HAVE ALTERNATING REFLECTORIZED WHITE AND REFLECTORIZED ORANGE STRIPES SLOPING DOWNWARD AS SHOWN AT 45° TOWARD THE SIDE ON WHICH TRAFFIC WILL PASS. TYPE II BARRICADES SHALL BE STRIPED ON BOTH SIDES. TYPE III BARRICADES SHALL BE STRIPED ON BOTH SIDES WHERE TRAFFIC APPROACHES FROM EITHER DIRECTION. VERTICAL PANELS LOCATED ON THE OUTSIDE OF CURVES SHALL BE STRIPED ON BOTH SIDES.
- DRUMS 5. DRUMS SHALL BE NONMETALLIC AND HAVE ALTERNATING REFLECTORIZED ORANGE AND REFLECTORIZED WHITE HORIZONTAL CIRCUMFERENTIAL STRIPES AS SHOWN. THERE SHALL BE AT LEAST TWO ORANGE AND TWO WHITE STRIPES ON EACH DRUM. IF NONREFLECTIVE SPACES ARE LEFT BETWEEN THE ORANGE AND WHITE STRIPES, THEY SHALL BE NO MORE THAN 2" IN WIDTH. ALL NON-REFLECTORIZED PORTIONS OF THE DRUM SHALL BE ORANGE OR WHITE. DRUMS MAY BE SLIGHTLY CONICAL IN SHAPE AND HAVE ONE OR MORE FLAT SURFACES TO MINIMIZE ROLLING WHEN HIT. DRUMS MAY BE WEIGHTED INTERNALLY WITH JUST ENOUGH SAND, OR OTHER MATERIAL TO PROVIDE STABILITY.
- TYPE II BARRICADES 6. FRAMES FOR TYPE II BARRICADES SHALL BE NON-METALLIC, PROVIDE A STABLE SUPPORT, AND HAVE NO RIGID STAY BRACING FOR "A" FRAME DESIGNS. THE PREDOMINANT COLOR FOR NON-REFLECTORIZED BARRICADE COMPONENTS SHALL BE ORANGE OR WHITE.
- TYPE III BARRICADES 7. TYPE III BARRICADES SHALL NOT HAVE ANY VERTICAL OR SLOPING SUPPORTS HEAVIER THAN 4" x 4" LUMBER, 2" x 2" STEEL TUBING, OR 2" x 2" STEEL ANGLES. SIGNS SHALL NOT BE ERECTED ON TYPE III BARRICADES.
- CONES 8. MINIMUM WEIGHT SHALL BE 7 LBS. FOR 28" HIGH CONES WITH A MINIMUM OF 60 PERCENT OF THE TOTAL WEIGHT IN THE BASE.
- I.D. 9. BARRICADES MAY BE IDENTIFIED WITH A LEGEND THAT DOES NOT EXCEED ONE INCH IN HEIGHT ON A NON-REFLECTIVE SURFACE IN A LOCATION NOT VISIBLE TO TRAFFIC.
- WEIGHTS 10. WEIGHTS OF CONCRETE, STONE OR BRICK WILL NOT BE ALLOWED AND ALL WEIGHTS OTHER THAN SANDBAGS MUST BE RIGIDLY ATTACHED TO THE BARRICADES AS CLOSE TO THE GROUND AS POSSIBLE. NO WEIGHTS WILL BE ALLOWED ON THE TOP RAIL OF BARRICADES. SANDBAGS MAY BE PLACED ON THE BARRICADE LEGS, OVER THE STRIPED BOTTOM RAILS NOT FACING TRAFFIC OR SUSPENDED FROM THE BARRICADE RAIL OR FRAME IN SUCH A MANNER SO THAT THE BULK OF THE SAND IS AT LEAST 18" BELOW THE TOP OF THE BARRICADE.
- LIGHTS 11. WARNING LIGHTS ON BARRICADES, DRUMS OR VERTICAL PANELS SHALL BE MOUNTED ABOVE THE TOP OF THE DEVICE TO THE SIDE ON WHICH TRAFFIC WILL PASS AND SHALL NOT OBSCURE ANY REFLECTORIZED PORTION OF THE DEVICE.
- VERTICAL PANELS 12. VERTICAL PANELS MAY BE EITHER POST MOUNTED, FRAME SUPPORTED OR ATTACHED TO THE TOP OF A BARRIER. POST MOUNTED PANELS SHALL BE FIRMLY ATTACHED TO LIGHT WEIGHT METAL POSTS WITH A TOP HEIGHT OF 48" ABOVE THE PAVEMENT SURFACE, OR AS APPROVED BY THE ENGINEER.
- FLAGGER PADDLE FACE 13. THE "STOP" FACE SHALL CONSIST OF WHITE LETTERS AND BORDER ON A RED REFLECTORIZED BACKGROUND. THE "SLOW" FACE SHALL CONSIST OF BLACK LETTERS AND BORDER ON A FLUORESCENT ORANGE REFLECTORIZED BACKGROUND. AREAS OUTSIDE THE SIGN BORDERS SHALL BE LIGHT BLUE OR BLACK. ALL COLORS AND LETTERS SHALL MEET APPLICABLE FEDERAL STANDARDS.
- FLAGGER PADDLE SHAFT 14. THE SHAFT SHALL CONSIST OF TWO SECTIONS JOINED BY A COUPLING LOCATED 60 INCHES FROM THE BOTTOM OF THE SHAFT. THE PORTION OF THE STAFF WITHIN THE SIGN FACE SHALL MATCH THE SIGN COLORS.
- FLAGGER SIGN 15. THE SIGN BASE MATERIAL SHALL BE 0.08 INCH THICK ALUMINUM. THE SIGN SHALL BE ATTACHED TO THE STAFF WITH RUST RESISTANT HARDWARE.
- FLAGGER PADDLE USAGE 16. THE SIGN SHALL BE FURNISHED BY THE CONTRACTOR AND SHALL BE USED BY THE FLAGGER IN LIEU OF FLAGS OR OTHER SIGNALING DEVICES.
- SIGN MOUNTING 17. CONSTRUCTION SIGNS MOUNTED FOR SHORT TERM CLOSURES, LESS THAN 12 HOURS, MAY BE PLACED ON PORTABLE STANDS AS SHOWN. CONSTRUCTION SIGNS MOUNTED FOR NIGHTTIME OR MOUNTED LONGER THAN A SHORT TERM CLOSURE SHALL BE GROUND, PAVEMENT OR SHOULDER MOUNTED.
- 18. MOUNTING OF ANY SIGNS ON TYPE III BARRICADES SHALL NOT BE ALLOWED.
- 19. ALL MOT DEVICES AND SIGN SUPORTS SHALL BE CERTIFIED AS MEETING THE REQUIRED TEST LEVEL OF NCHRP REPORT 350.

APPROVED *Jeff Daley* CHIEF ENGINEER DATE 5-28-2004

CTE ENGINEERS
CONSOER TOWNSEND ENVIRODYNE ENGINEERS, INC.

THE ILLINOIS STATE TOLL HIGHWAY AUTHORITY
2700 OGDEN AVENUE
DOWNERS GROVE, ILLINOIS 60515

REVISIONS	
NO.	DESCRIPTION
1	6/1/04 CORRECTIONS

STANDARD SD 04-10A
STANDARD PROTECTIVE DEVICES

DRAWING NO. E1 OF