

STATE OF ILLINOIS
DEPARTMENT OF TRANSPORTATION

ROUTE NO.	SECTION	COUNTY	TOTAL SHEETS	SHEET NO.	SHEET NO. 2 2 SHEETS
		Champaign	9	7	
FED. ROAD DIST. NO. 7	ILLINOIS	FED. AID PROJECT			

Contract Number: 70548

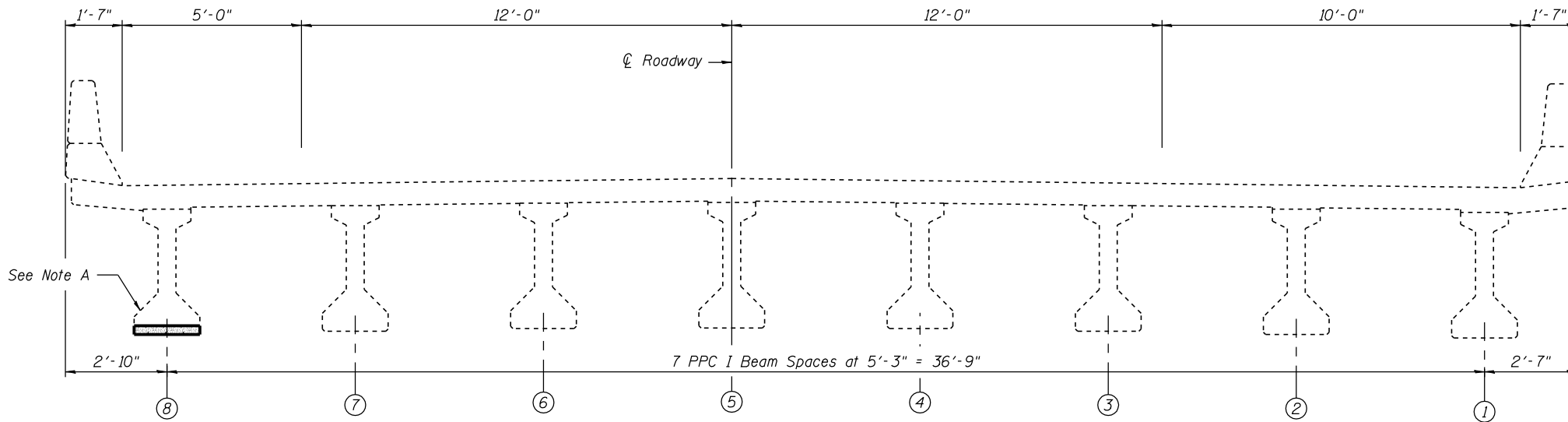

CROSS SECTION SPANS 1 AND 3
(Looking West)

Note A:
PPC I-Beams to be repaired as detailed.

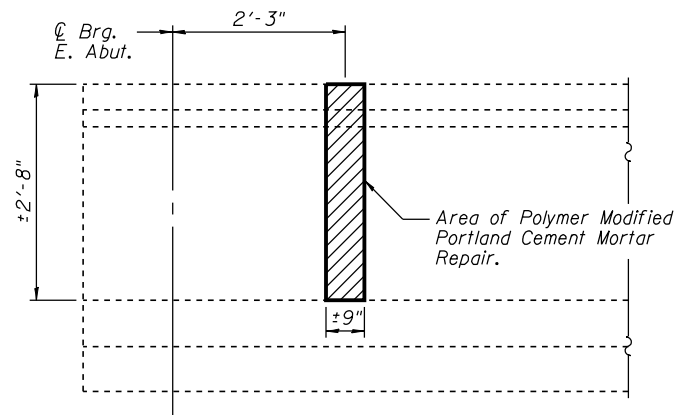

ELEVATION BEAM 8
(Looking South)

PRELOADING FOR PPC I-BEAM REPAIRS
(Service Moment)

SOUTH FASCIA

Span	Location		Moment (kip-ft)
	From	Distance	
3	E. Abutment	35'-0"	490

REPAIR PROCEDURES FOR BEAM 8
(SPANS 1 AND 3)

- The damaged area of the beam shall be cleaned of all loose and spalled concrete, and sealant. Hand tools shall be used for the removal of concrete adjacent to the prestressing strands. While a 15 pound chipping hammer may be used away from prestressing strands, extreme care shall be taken not to damage the exposed prestressing strands. Any exposed portions of the strands shall be sandblasted.
- Using the same tools, remove the existing concrete to sound concrete along the edges of the damaged area to a depth of 1" min. to 1 1/2" max. The edges shall be saw cut 3/4" deep or less.
- Power driven pins as shown in Detail A shall be placed at 9" alternate centers along damaged length of beam at locations shown in Detail A. Use wire ties in areas where the strands are exposed as shown in Detail A. Place 1" x 1" x 18 gauge welded wire fabric in repair areas and attach it to the pins or strands with wire ties. The clearance between the finished surface of the new concrete and the welded wire fabric shall be 1" minimum. All beams involved in this work shall be rebuilt to their original dimensions.
- All surfaces of existing concrete and reinforcing strands in the area to be repaired shall be coated with an epoxy-resin primer bonding agent. The concrete beam to be repaired or crack sealed must be at a temperature of at least 50° F. or higher. All other minor mortar repair, crack sealing, or surface sealing of gouges on the beam shall be performed as directed by the Engineer.
- The repair shall be made using a concrete meeting all the requirements specified in Section 1020 of the Standard Specifications for Class PS Concrete for precast prestressed concrete members, except the maximum size of the aggregate shall be 1/2". Place the lower form on the bottom of the beam and compact by vibrating (or other approved methods) the concrete mix into the voids. After accessible voids have been filled and compacted, the top vertical form shall be raised into position and the remaining voids filled and compacted. The sloping upper surface shall be finished to the configuration of the existing PPC I-Beam flange.

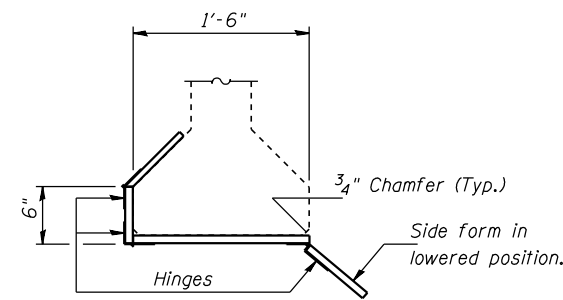

SUGGESTED FORM DETAIL

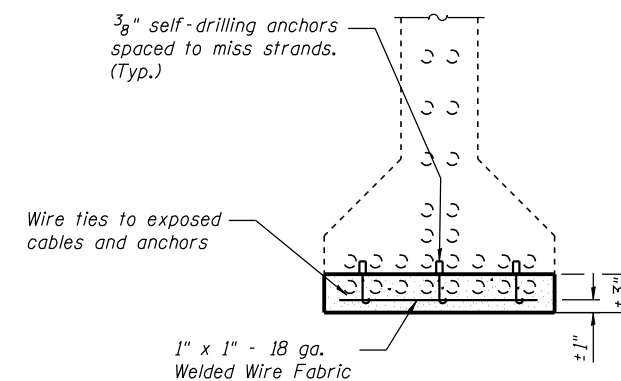

DETAIL A

Note:
The cost of concrete removal, Class PS Concrete, power driven pins, wire ties, wire mesh, epoxy bonding agent, Epoxy Crack Sealing and all other work required to perform repairs on Beam 8 in Spans 1 and 3 shall be included in the cost of P.P.C. I Beam Repairs.

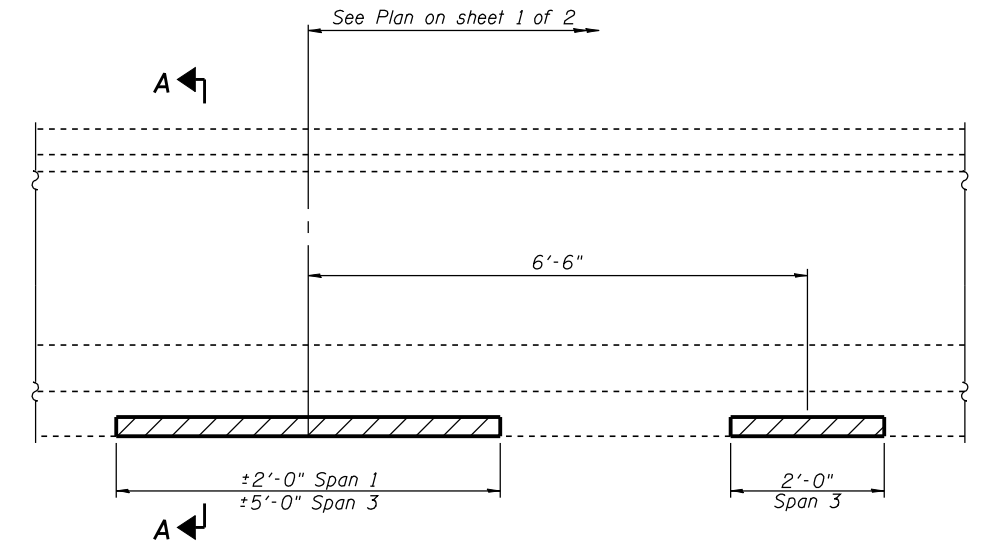

ELEVATION BEAM 8
(Looking North)

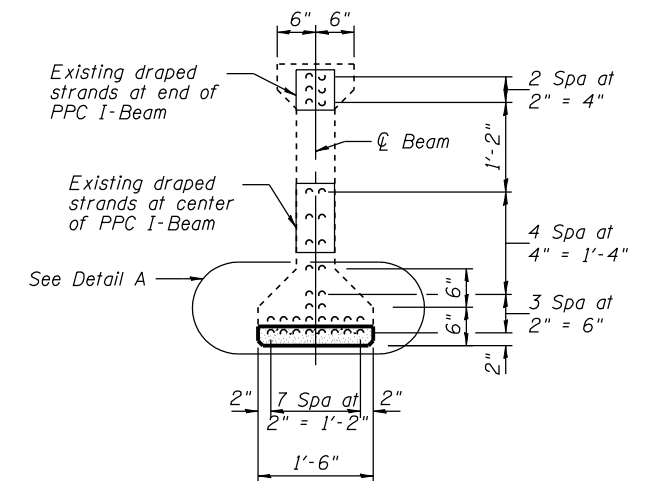

SECTION A-A
PATCHING DETAIL
Beam 8, Spans 1 and 3

PPC - BEAM REPAIR DETAILS
F.A.I. RT 74
W.B. I-74 / SALT FORK RIVER
CHAMPAIGN COUNTY
SN 010-0030

DESIGNED	V.H.V.
CHECKED	S.J.B.
DRAWN	Drew Christopher
CHECKED	V.H.V. S.J.B.

EXAMINED	John A. Morris ENGINEER OF STRUCTURAL SERVICES	MAY 8, 2006
PASSED	Ralph E. Anderson ENGINEER OF BRIDGES AND STRUCTURES	