

F.A. RTE.	SECTION	COUNTY	TOTAL SHEETS	SHEET NO.
*	**	***	310	5

STA. _____ TO STA. _____

CONTRACT NO. 74155

- * PARK ROADS
- ** SFWA PARK ROADS 2003-1
- *** MOULTRIE AND SHELBY

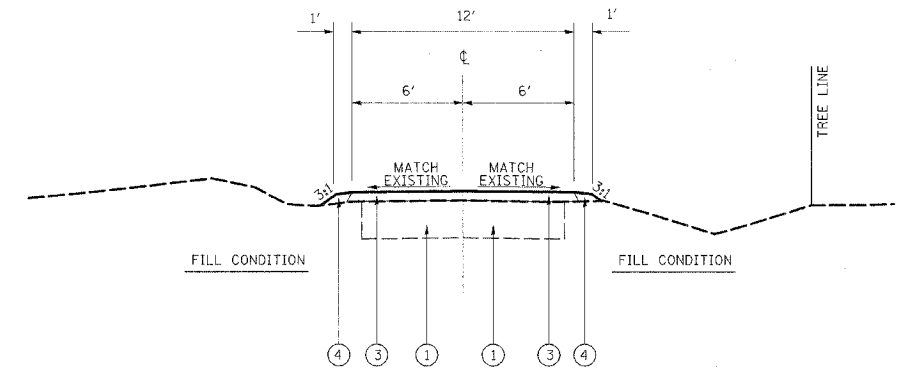

TR 89 TO PARKING LOT 2
PROPOSED TYPICAL SECTION
 STATION 9+81.93 TO STATION 25+10.95

- LEGEND**
- ① EXISTING AGGREGATE SURFACE
 - ② EXISTING OIL & CHIP
 - ③ PROPOSED AGGREGATE SURFACE COURSE, TYPE B, 3"
 - ④ PROPOSED EARTH SHOULDER (SLOPE 3/4" FT)
 - ⑤ PROPOSED BITUMINOUS SURFACE TREATMENT CLASS A-1
 - ⑥ PROPOSED BITUMINOUS SURFACE TREATMENT CLASS A-2
 - ⑦ EXISTING BITUMINOUS CONCRETE SURFACE
 - ⑧ PREPARATION OF BASE

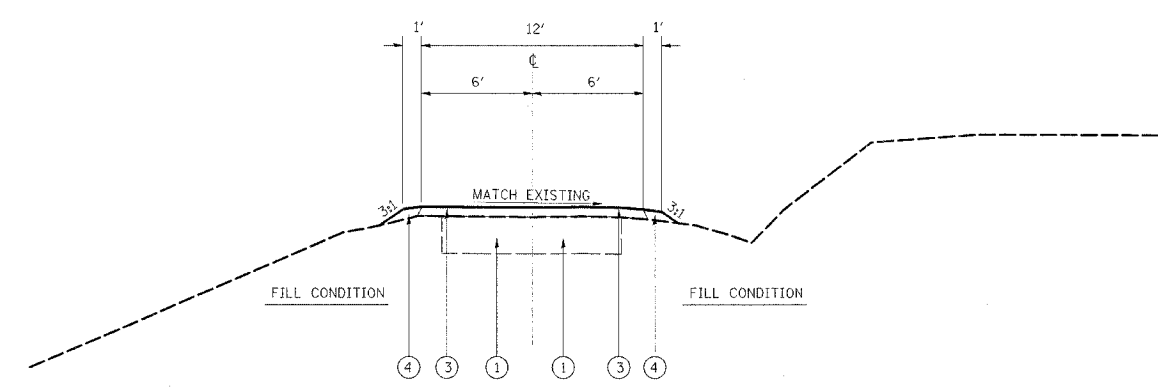

PARK ROAD TO PARKING LOT 4
PROPOSED TYPICAL SECTION
 STATION 1+34.08 TO STATION 2+39.76

REVISIONS	
NAME	DATE

ILLINOIS DEPARTMENT OF TRANSPORTATION
PROPOSED TYPICAL SECTION
WEST OKAW FISH & WILDLIFE UNIT
TR 89 TO PARKING LOT 2
PARK ROAD TO PARKING LOT 4

SCALE: _____ DRAWN BY WILL
 DATE _____ CHECKED BY STEUART