

F.A. RTE.	SECTION	COUNTY	TOTAL SHEETS	SHEET NO.
*	**	***	310	11

STA. TO STA.
CONTRACT NO. 74155

- * PARK ROADS
- ** SFWA PARK ROADS 2003-1
- *** MOULTRIE AND SHELBY

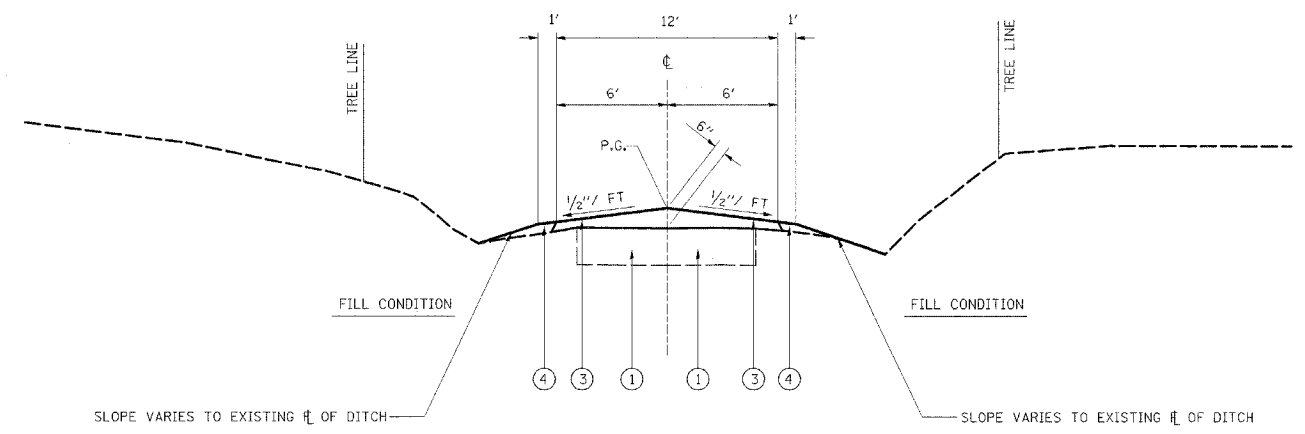

TR 117B TO PARKING LOT 30
PROPOSED TYPICAL SECTION
STATION 10+40.00 TO STATION 12+75.00

- LEGEND**
- ① EXISTING AGGREGATE SURFACE
 - ② EXISTING OIL & CHIP
 - ③ PROPOSED AGGREGATE SURFACE COURSE, TYPE B, 3"
 - ④ PROPOSED EARTH SHOULDER (SLOPE 3/4" FT)
 - ⑤ PROPOSED BITUMINOUS SURFACE TREATMENT CLASS A-1
 - ⑥ PROPOSED BITUMINOUS SURFACE TREATMENT CLASS A-2
 - ⑦ EXISTING BITUMINOUS CONCRETE SURFACE
 - ⑧ PREPARATION OF BASE

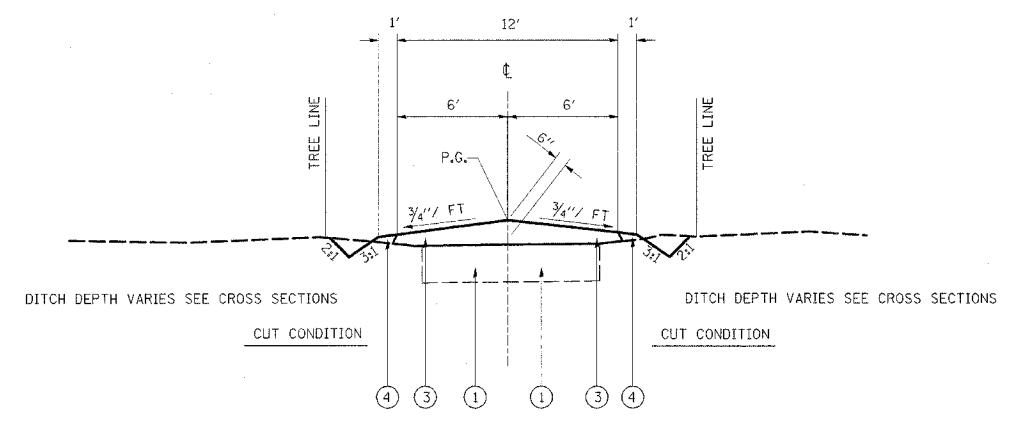

LOOP ROAD TO PARKING LOT 30
PROPOSED TYPICAL SECTION
STATION 0+06.15 TO STATION 1+90.59

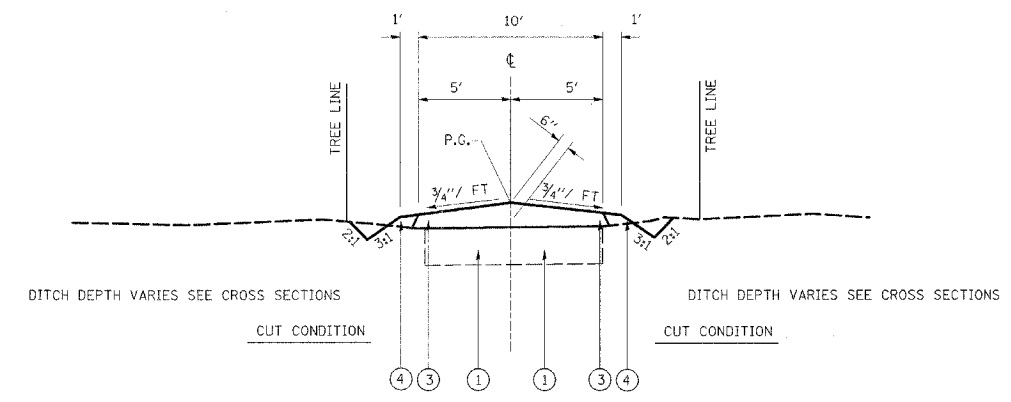

LOOP ROAD TO PARKING LOT 30
PROPOSED TYPICAL SECTION
STATION 1+90.59 TO STATION 7+56.98

REVISIONS	
NAME	DATE

ILLINOIS DEPARTMENT OF TRANSPORTATION
PROPOSED TYPICAL SECTION
WEST OKAW FISH & WILDLIFE UNIT
TR 117B TO PARKING LOT 30
LOOP ROAD TO PARKING LOT 30
SCALE: DRAWN BY WILL
DATE CHECKED BY STEUART