

F.A.P. RTE.	SECTION	COUNTY	TOTAL SHEETS	SHEET NO.
*	**	***	310	15
STA. TO STA.				
CONTRACT NO. 74155				
<ul style="list-style-type: none"> * PARK ROADS ** SFWA PARK ROADS 2003-1 *** MOULTRIE AND SHELBY 				

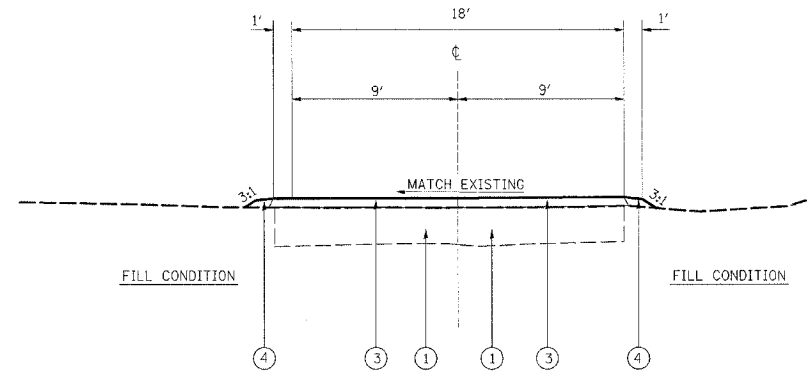

PARK ROAD TO PARKING LOT 59
PROPOSED TYPICAL SECTION
 STATION 2+06.5 TO STATION 3+18.48

- LEGEND**
- ① EXISTING AGGREGATE SURFACE
 - ② EXISTING OIL & CHIP
 - ③ PROPOSED AGGREGATE SURFACE COURSE, TYPE B, 3"
 - ④ PROPOSED EARTH SHOULDER (SLOPE 3/4" FT)
 - ⑤ PROPOSED BITUMINOUS SURFACE TREATMENT CLASS A-1
 - ⑥ PROPOSED BITUMINOUS SURFACE TREATMENT CLASS A-2
 - ⑦ EXISTING BITUMINOUS CONCRETE SURFACE
 - ⑧ PREPARATION OF BASE

REVISIONS	
NAME	DATE

ILLINOIS DEPARTMENT OF TRANSPORTATION
PROPOSED TYPICAL SECTION
KASKASKIA FISH AND WILDLIFE UNIT
PARK ROAD TO PARKING LOT 59

SCALE: _____ DRAWN BY BARGIEL
 DATE _____ CHECKED BY STEUART