

F.A. RTE.	SECTION	COUNTY	TOTAL SHEETS	SHEET NO.
*	**	***	310	16

STA. _____ TO STA. _____
 CONTRACT NO. 74155

- * PARK ROADS
- ** SFWA PARK ROADS 2003-1
- *** MOULTRIE AND SHELBY

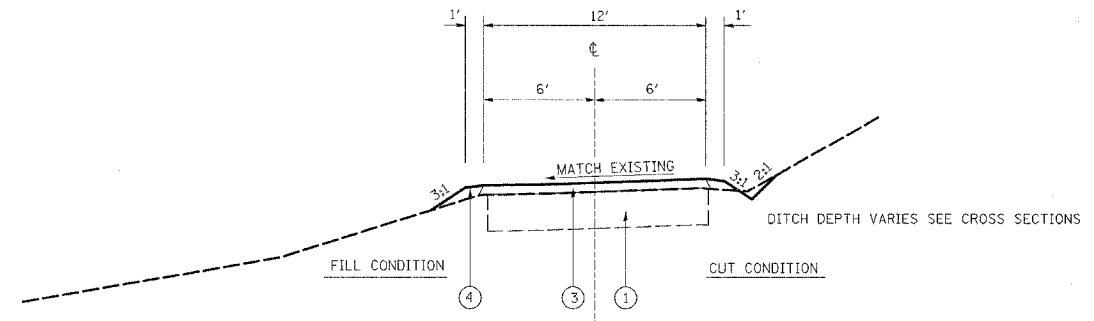

PARK ROAD TO PARKING LOT 60 AND 61
PROPOSED TYPICAL SECTION
 STATION 0+06.43 TO STATION 12+50

- LEGEND**
- ① EXISTING AGGREGATE SURFACE
 - ② EXISTING OIL & CHIP
 - ③ PROPOSED AGGREGATE SURFACE COURSE, TYPE B, 3"
 - ④ PROPOSED EARTH SHOULDER (SLOPE 3/4" / FT)
 - ⑤ PROPOSED BITUMINOUS SURFACE TREATMENT CLASS A-1
 - ⑥ PROPOSED BITUMINOUS SURFACE TREATMENT CLASS A-2
 - ⑦ EXISTING BITUMINOUS CONCRETE SURFACE
 - ⑧ PREPARATION OF BASE

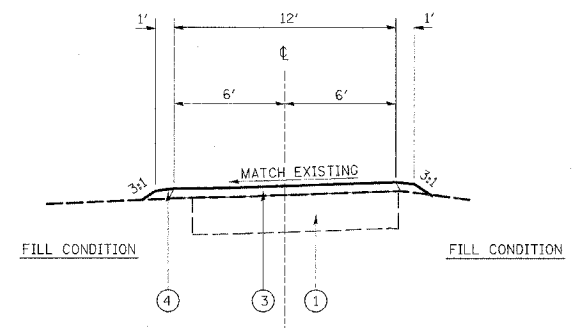

PARK ROAD TO PARKING LOT 60 AND 61
PROPOSED TYPICAL SECTION
 STATION 12+50 TO STATION 16+00

REVISIONS		ILLINOIS DEPARTMENT OF TRANSPORTATION
NAME	DATE	
		<p align="center">PROPOSED TYPICAL SECTION KASKASKIA FISH AND WILDLIFE UNIT PARK ROAD TO PARKING LOTS 60 AND 61</p> <p>SCALE: _____ DATE _____</p> <p>DRAWN BY BARGIEL CHECKED BY STEUART</p>