

STATE OF ILLINOIS
DEPARTMENT OF TRANSPORTATION

ROUTE NO.	SECTION	COUNTY	TOTAL SHEETS	SHEET NO.
F.A.P. 789	68-BR-1	MADISON	12	3
FED. ROAD DIST. NO. 7	ILLINOIS	FED. AID PROJECT		

Contract #76896

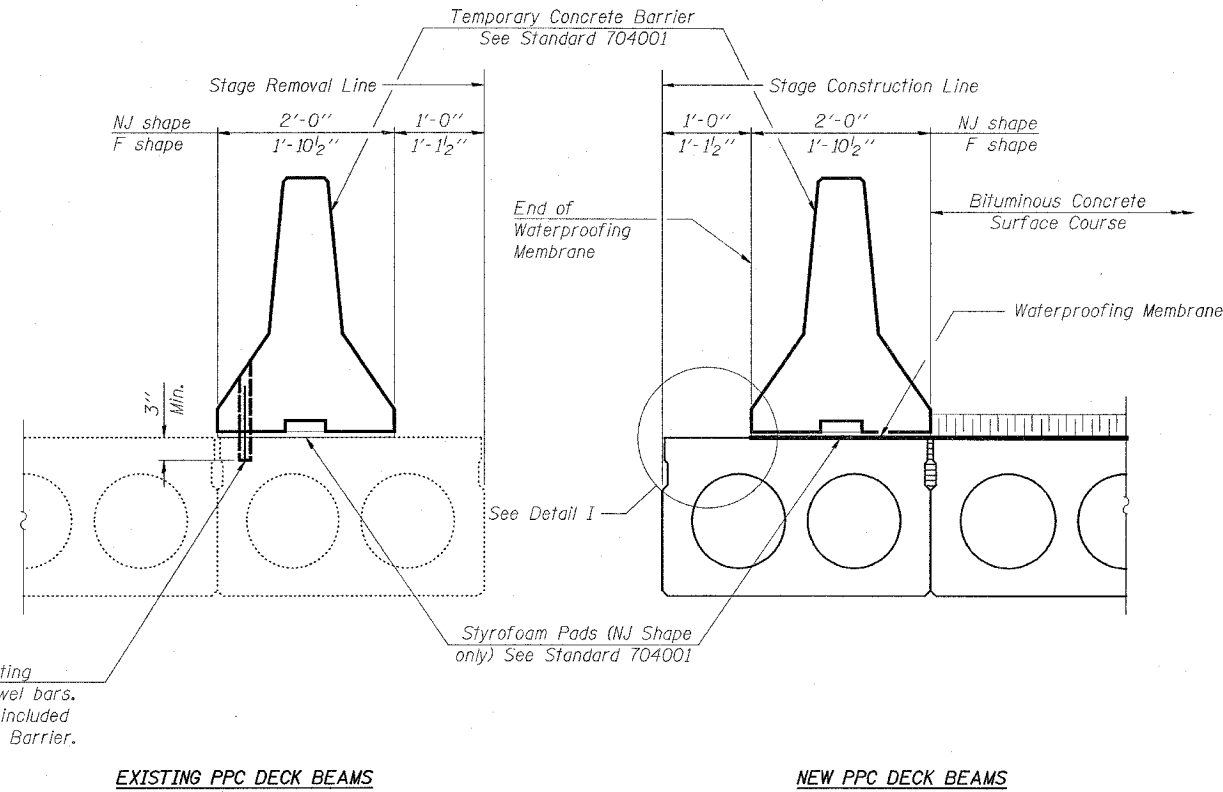

Drill 1/4" ϕ Holes in existing beam for 1" ϕ x 10" dowel bars. Traffic side only. Cost included with Temporary Concrete Barrier.

EXISTING PPC DECK BEAMS

NEW PPC DECK BEAMS

SECTIONS THRU PPC DECK BEAMS

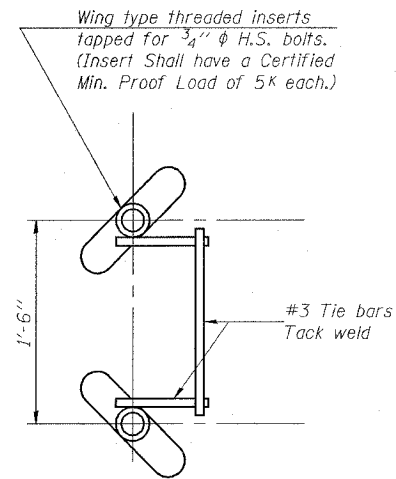

INSERT DETAIL

2 - Wing type threaded inserts for 3/4" ϕ H.S. bolts with flat hardened washer. Grout holes after removal.

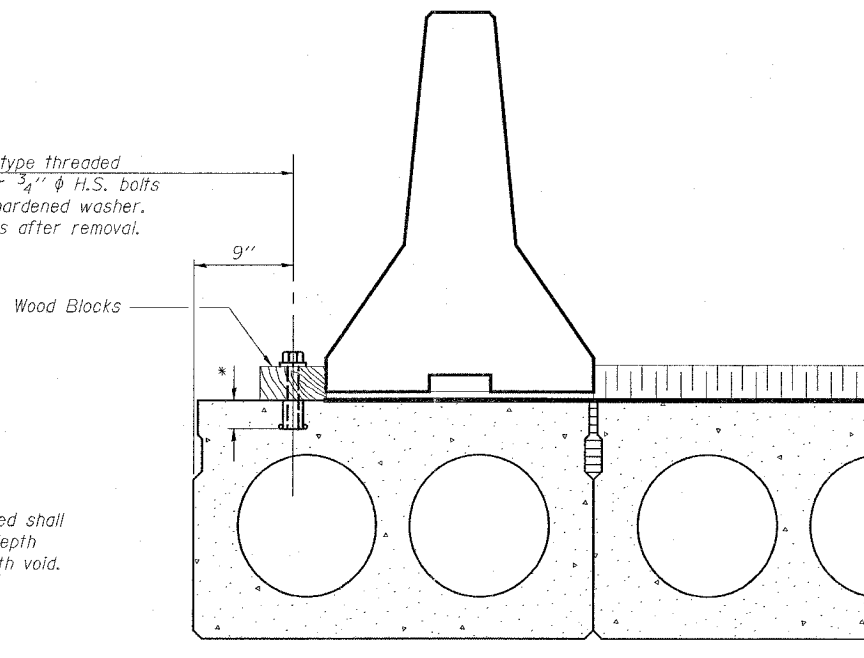

DETAIL I

The Temporary Concrete Barrier and wood blocks shall not be removed until Stage II Construction PPC Deck Beams have been placed and shear keys grouted.

NOTES

- The 3/4" ϕ high strength bolts used to connect the wood blocks shall be tightened to a snug fit without crushing the wood block.
- The wing type threaded insert assembly shall be spaced 6'-0" longitudinally.
- The Waterproofing Membrane shall extend under the Temporary Concrete Barrier without the asphalt sand seal protection layer. Once the Temporary Concrete Barrier has been removed, and the penetrating primer, coal tar emulsion, coal tar emulsion and fiberglass fabric, and coal tar emulsion slurry layers of the Waterproofing Membrane is lapped 6", the asphalt sand seal protection layer shall be applied according to Article 581 of the Standard Specifications.
- The cost for H.S. bolts, flat headed washers, and wood block is included with Temporary Concrete Barrier.
- The cost for wing type threaded inserts is included with Precast Prestressed Concrete Deck Beams (17" Depth).

DESIGNED	EML
CHECKED	NJM
DRAWN	EML
CHECKED	NJM

HORNER & SHIFRIN, INC.
ENGINEERS ■ ARCHITECTS ■ PLANNERS

**TEMPORARY CONCRETE BARRIER
FOR STAGE CONSTRUCTION
F.A.P. ROUTE 789 - SECTION 68-BR-1
MADISON COUNTY
STATION 98+33.25
STRUCTURE NO. 060-0150**