

DETAILS OF SURFACING AT INTERSECTIONS AND SIDEROADS

F.A.S.	SECTION	COUNTY	TOTAL SHEETS	SHEET NO.
880	93-0075-00-RS	HAMILTON	5	3
FED. ROAD DIST. NO. 1		ILLINOIS	DAHLOREN ROAD (EAST)	
PROJECT RS-880(105)		CONTRACT # 93263		

DETAIL OF TAPER AND RAILROAD CROSSING  
STA. 0+00 TO STA 2+25

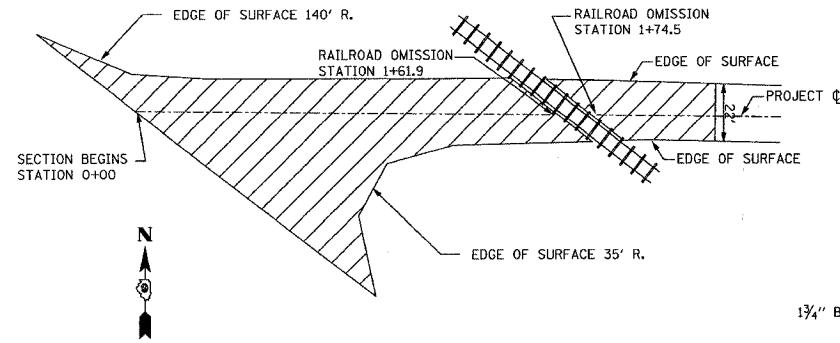

NOTE: THE QUANTITY SHOWN FOR BITUMINOUS CONCRETE SURFACE COURSE, SUPERPAVE, MIX "C", N50 INCLUDES 135.6 TONS OF MATERIAL FROM STATION 0+00 TO STATION 1+61.9 AND 23.5 TONS OF MATERIAL FOR THE RAILROAD OMISSION FROM STATION 1+74.5 TO STATION 2+24.5.

BUTT JOINT DETAIL  
STA 1+74.5 TO STA 2+24.5

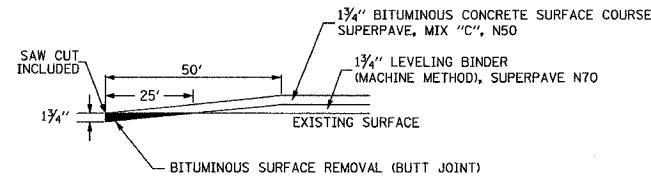

BUTT JOINT DETAIL  
STA 1+11.9 TO STA 1+61.9

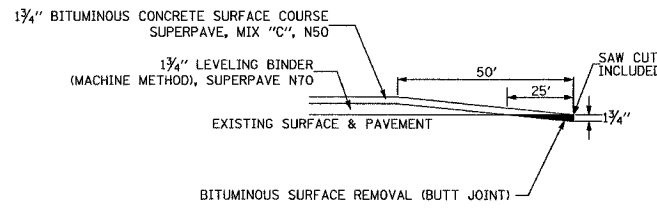

TEMPORARY RAMP DETAIL  
STA 1+74.5 TO STA 1+78.67

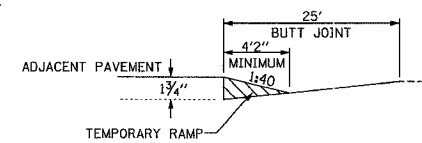

TEMPORARY RAMP DETAIL  
STA 1+57.73 TO STA 1+61.9

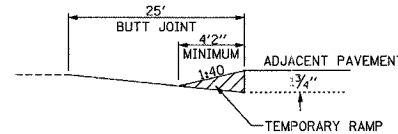

DETAIL OF INTERSECTION LT. STA. 2+65

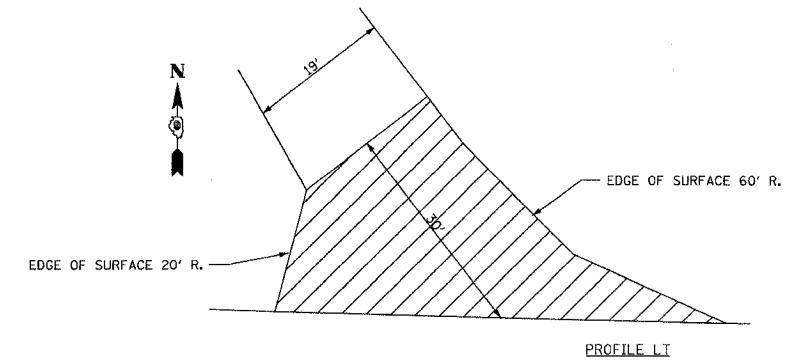

NOTE: THE QUANTITY SHOWN FOR BITUMINOUS CONCRETE SURFACE COURSE, SUPERPAVE, MIX "C", N50 INCLUDES 18.9 TONS OF MATERIAL FOR THE SIDEROAD APPROACH AND RADII.

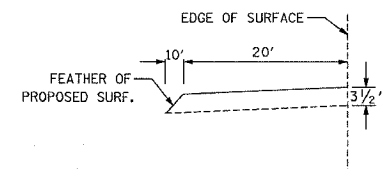

DETAIL OF INTERSECTION LT. STA. 3+35

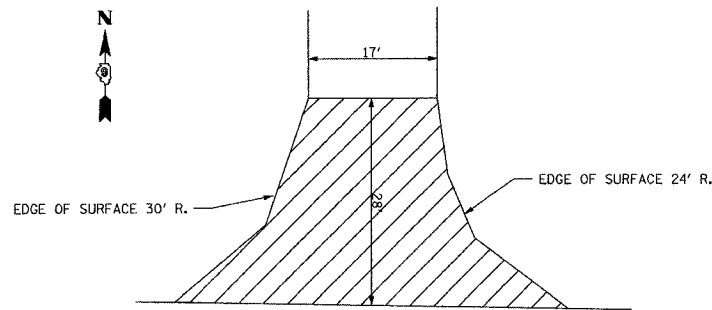

NOTE: THE QUANTITY SHOWN FOR BITUMINOUS CONCRETE SURFACE COURSE, SUPERPAVE, MIX "C", N50 INCLUDES 17.4 TONS OF MATERIAL FOR THE SIDEROAD APPROACH AND RADII.

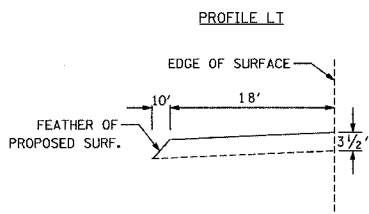

DETAIL OF INTERSECTION LT. STA. 49+30 & RT. 49+36

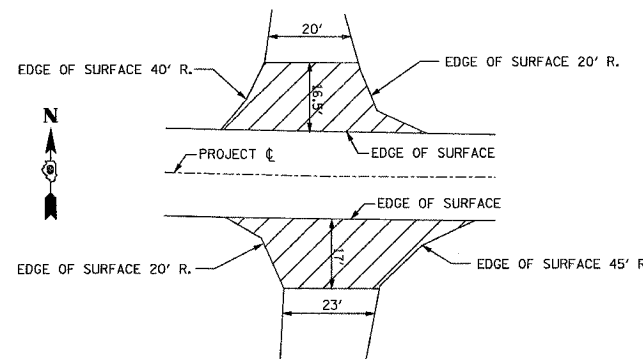

NOTE: THE QUANTITY SHOWN FOR BITUMINOUS CONCRETE SURFACE COURSE, SUPERPAVE, MIX "C", N50 INCLUDES 11.4 TONS OF MATERIAL FOR THE SIDEROAD LT. APPROACH AND RADII AND 13.4 TONS OF MATERIAL FOR THE SIDEROAD RT. APPROACH AND RADII.

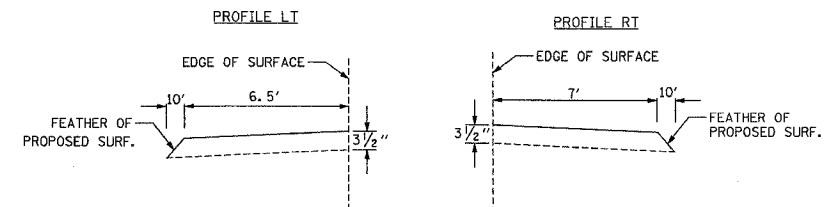

DETAIL OF INTERSECTION LT. STA. 102+50 & RT. STA. 102+58

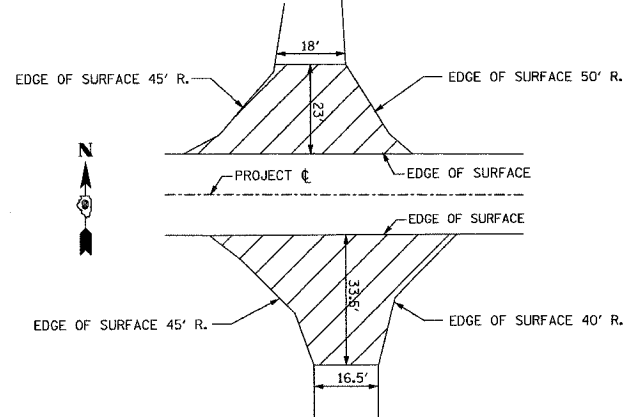

NOTE: THE QUANTITY SHOWN FOR BITUMINOUS CONCRETE SURFACE COURSE, SUPERPAVE, MIX "C", N50 INCLUDES 17.3 TONS OF MATERIAL FOR THE SIDEROAD LT. APPROACH AND RADII AND 24.3 TONS OF MATERIAL FOR THE SIDEROAD RT. APPROACH AND RADII.

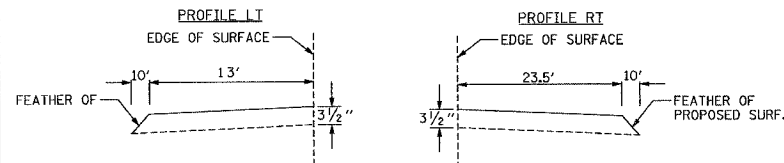

DETAIL OF INTERSECTION LT. STA. 154+66

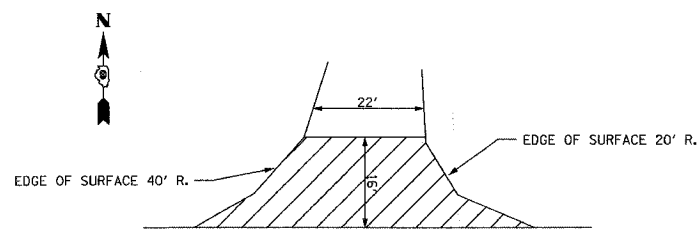

NOTE: THE QUANTITY SHOWN FOR BITUMINOUS CONCRETE SURFACE COURSE, SUPERPAVE, MIX "C", N50 INCLUDES 12.8 TONS OF MATERIAL FOR THE SIDEROAD APPROACH AND RADII.

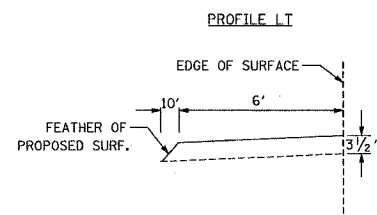

DETAIL OF TAPER STA. 206+00 TO STA 206+25

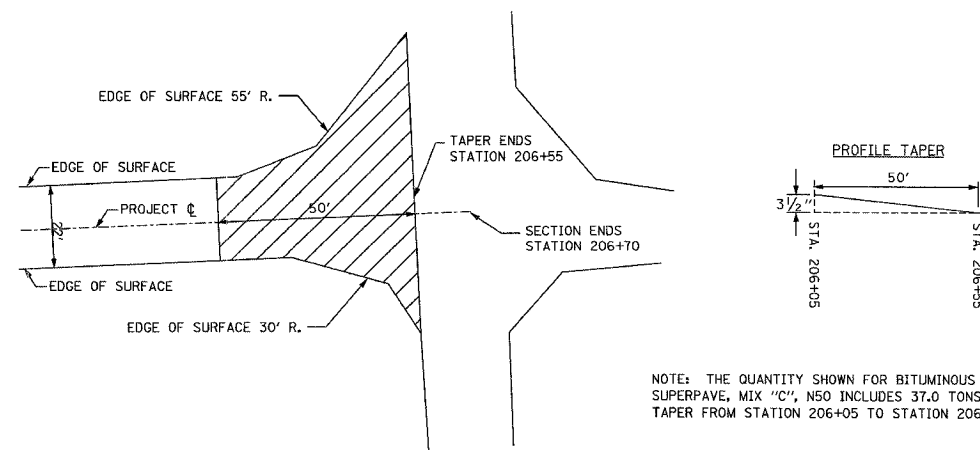

NOTE: THE QUANTITY SHOWN FOR BITUMINOUS CONCRETE SURFACE COURSE, SUPERPAVE, MIX "C", N50 INCLUDES 37.0 TONS OF MATERIAL FOR THE TAPER FROM STATION 206+05 TO STATION 206+55

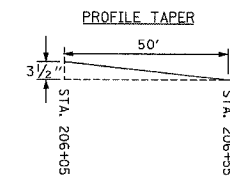

PROFESSIONAL DESIGN FIRM  
LAND SURVEY & PROFESSIONAL ENGINEERING CORPORATION  
184-00887  
(62-032435)(35-002769)



AARON M. MEFFORD  
NAME  
*Aaron Mefford*  
SIGNATURE  
05-16-06  
DATE  
11-30-07  
EXPIRES