

REVISIONS		
NUMBER	BY	DATE

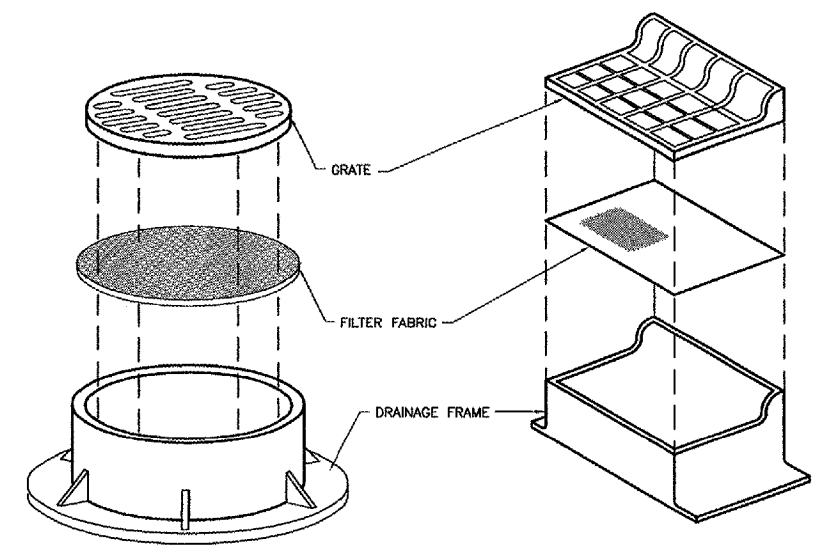
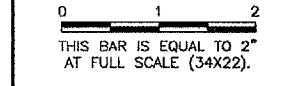

**NOTES:**

1. FILTER WRAP TO BE PLACED IN ALL SLOPE BOXES, INLETS, MANHOLES, TRENCH DRAINS AND CATCH BASINS LOCATED IN PAVED AREAS AND NONPAVED AREAS.
2. FABRIC SHALL BE IN CONFORMANCE WITH MATERIALS SPECIFIED FOR FABRIC FENCE.
3. FABRIC SHALL OVERLAY FRAME BY 2-INCH (MINIMUM).
4. CONTRACTOR SHALL CLEAR DEBRIS AND SILT AS REQUIRED FROM FABRIC TO MAINTAIN DRAINAGE THROUGH THE STRUCTURE.
5. FABRIC SHALL REMAIN IN PLACE UNTIL TURFED AREAS HAVE DEVELOPED A MINIMUM OF 80% OF COVERAGE.
6. COST OF FILTER WRAP SHALL BE CONSIDERED INCIDENTAL TO INLET PROTECTION.

**DRAINAGE STRUCTURE FILTER WRAP**  
 NOT TO SCALE

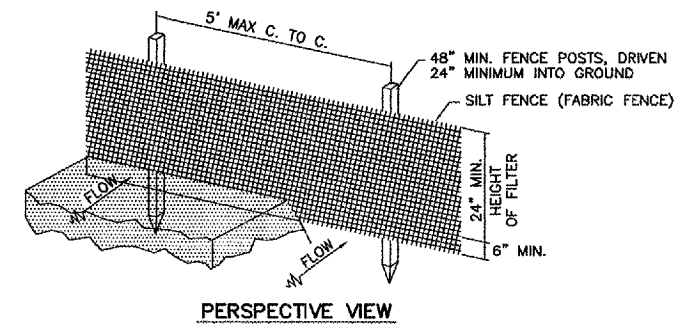

**PERSPECTIVE VIEW**

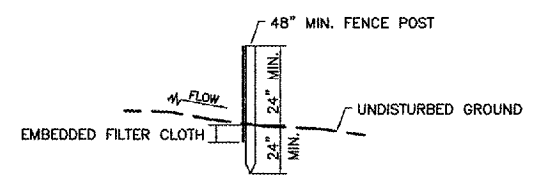

**SECTION**

**EROSION CONTROL FABRIC FENCE DETAIL**  
 NOT TO SCALE

**CONSTRUCTION NOTES FOR SILT (FABRIC) FENCE**

1. WHEN TWO SECTIONS OF FILTER CLOTH ADJOIN EACH OTHER THEY SHALL BE OVER-LAPPED BY 6-INCH MIN. AND FOLDED.
2. MAINTENANCE SHALL BE PERFORMED AS NEEDED AND MATERIAL REMOVED WHEN "BULGES" DEVELOP IN THE SILT FENCE. MAINTENANCE, WHICH INCLUDES THE REPLACEMENT OF DAMAGED FENCE, SHALL BE CONSIDERED INCIDENTAL TO THE COST OF THE EROSION CONTROL FENCE.
3. SILT FENCE SHALL BE INSTALLED PER STORM WATER POLLUTION PREVENTION PLAN OR AS DIRECTED BY THE ENGINEER.

**SOIL PROTECTION CHART**  
 CHART PROVIDED BY KDSWCD

STABILIZATION TYPE	JAN	FEB	MAR	APR	MAY	JUNE	JULY	AUG	SEPT	OCT	NOV	DEC
PERMANENT SEEDING			+ A		+ A1	*	*			+ A1		
DORMANT SEEDING	B										+ B	
TEMPORARY SEEDING			+ C			D						
SODDING			+ E **									
MULCHING	F											

- A KENTUCKY BLUEGRASS 100 LBS/ACRE  
 PERENNIAL RYEGRASS 60 LBS/ACRE  
 CREEPING RED FESCUE 40 LBS/ACRE
- B KENTUCKY BLUEGRASS 100 LBS/ACRE  
 PERENNIAL RYEGRASS 60 LBS/ACRE  
 CREEPING RED FESCUE 40 LBS/ACRES  
 + 1 TON HYDROMULCH
- C SPRING OATS 100 LBS/ACRE
- D WHEAT OR CEREAL RYE  
 150 LBS/ACRE
- E SOD
- F HYDROMULCH 1 TON/ACRE
- \* IRRIGATION NEEDED DURING JUNE AND JULY
- \*\* IRRIGATION NEEDED FOR 2 TO 3 WEEKS AFTER APPLYING SOD

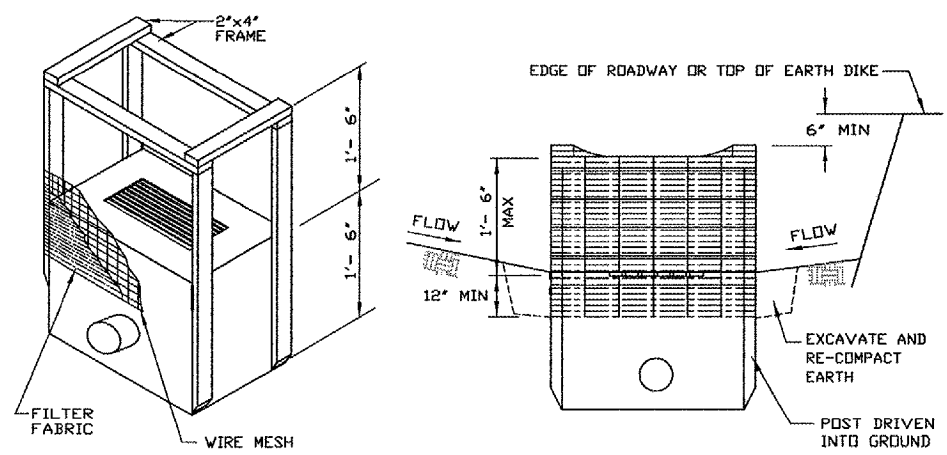

**INLET PROTECTION**

FROM NRCS STANDARD DRAWING NO. IL-560

**NOTES:**

1. FILTER FABRIC SHALL MEET THE REQUIREMENT OF AR156510 SILT FENCE.
2. THE WIRE MESH SHALL HAVE A MAXIMUM OPENING OF AT LEAST 6 INCHES.

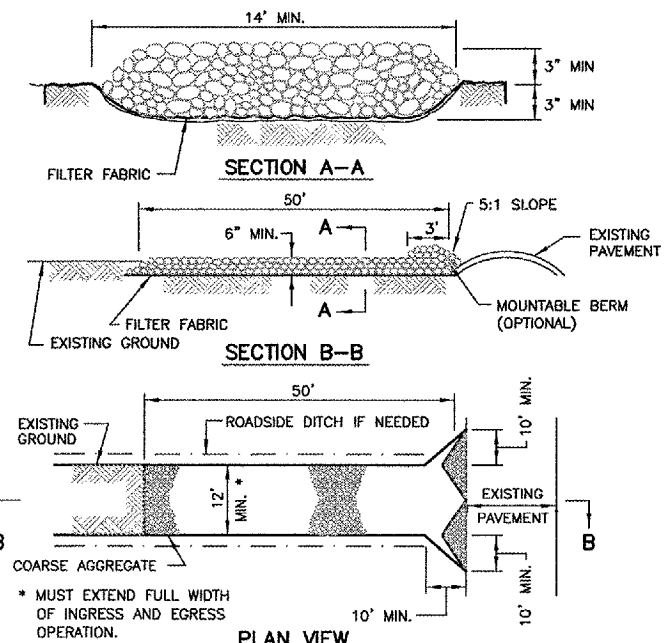

**STABILIZED CONSTRUCTION ENTRANCE**

FROM NRCS STANDARD DRAWING NO. IL-630

1. FILTER FABRIC SHALL MEET THE REQUIREMENTS OF MATERIAL SPECIFIED FOR AR152540 IN THE ILLINOIS DEPARTMENT OF TRANSPORTATION DIVISION OF AERONAUTICS SUPPLEMENTAL SPECIFICATIONS AND RECURRING SPECIAL PROVISIONS.
2. ROCK OR RECLAIMED CONCRETE SHALL MEET ONE OF THE FOLLOWING IDOT COARSE AGGREGATE GRADATION, CA-1, CA-2, CA-3 OR CA-4.
3. ANY DRAINAGE FACILITIES REQUIRED BECAUSE OF WASHING SHALL BE CONSTRUCTED ACCORDING TO MANUFACTURERS SPECIFICATIONS AND SHALL BE INCIDENTAL TO THE CONTRACT.
4. MINIMUM WIDTH IS 12' FOR ONE-WAY TRAFFIC AND 20' FOR TWO WAY TRAFFIC. TWO-WAY TRAFFIC WIDTHS SHALL BE INCREASED A MINIMUM OF 4' FOR TRAILER TRAFFIC. DEPENDING ON THE TYPE OF VEHICLE OR EQUIPMENT, SPEED, LOADS, CLIMATIC AND OTHER CONDITIONS UNDER WHICH VEHICLES AND EQUIPMENT OPERATE AN INCREASE IN THE MINIMUM WIDTHS MAY BE REQUIRED.
5. ROADWAY SHALL FOLLOW THE CONTOUR OF THE NATURAL TERRAIN TO THE EXTENT POSSIBLE.
6. STABILIZED CONSTRUCTION ENTRANCE SHALL BE INCIDENTAL TO THE CONTRACT.

**AURORA MUNICIPAL AIRPORT**  
**AURORA, ILLINOIS**  
**CONSTRUCT RUNWAY 33 ILS,**  
**RELOCATE RUNWAY 9 LOCALIZER**  
**STORMWATER POLLUTION**  
**PREVENTION PLAN**  
**DETAILS**

© Copyright CMT, Inc.  
**CMT**  
 CRAWFORD, MERRITT & TILLY, INC.  
 CONSULTING ENGINEERS  
 License No. 084-000618

DESIGN BY:	JWD
DRAWN BY:	JRO
CHECKED BY:	CAL
APPROVED BY:	
DATE:	05/12/06
JOB No:	04285-04
ILLINOIS PROJECT: ARR-3468 A.I.P. PROJECT: 3-17-0003-B31	
<b>FINAL SUBMITTAL</b>	
SHEET 15 OF 67 SHEETS	