

**PEDESTRIAN GATE ARRANGEMENT**

**VEHICLE GATE ARRANGEMENT**

**PULL POST ARRANGEMENT**

**LINE POST ARRANGEMENT**

**CORNER OF END POST ARRANGEMENT**

**NOTES:**  
 1. PULL POSTS SHALL BE PLACED AT LOCATIONS DETERMINED BY THE ENGINEER THEY SHALL BE PLACED AT 660-FOOT INTERVALS BETWEEN POSTS TO WHICH THE ENDS OF THE FABRIC ARE CLAMPED OR MIDWAY BETWEEN SUCH POSTS WHEN THE DISTANCE IS LESS THAN 1320' AND GREATER THAN 660'  
 2. WHERE FENCE HAS A CHANGE IN DIRECTION OF 15° OR MORE, A TERMINAL POST SHALL BE PLACED AS SHOWN ABOVE.

REVISIONS		
NUMBER	BY	DATE

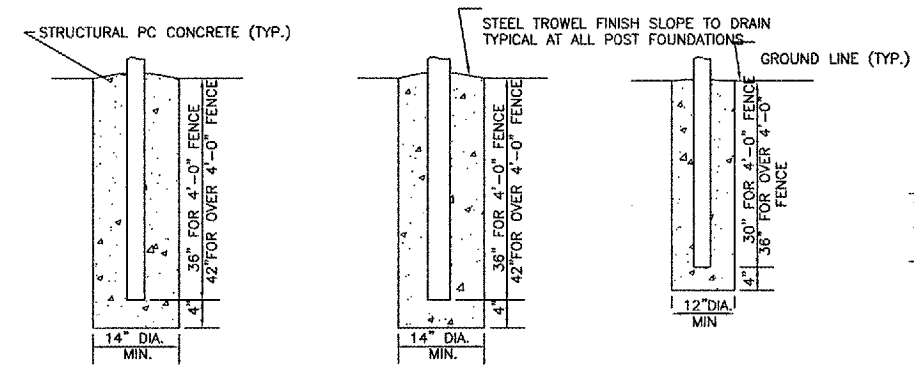
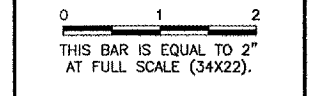

**FOOTING FOR TERMINAL POST**

**FOOTING FOR GATE POST**

**FOOTING FOR LINE POST**

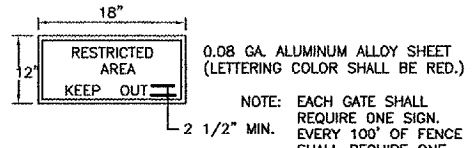

**SIGN DETAIL**

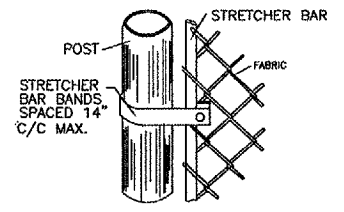

**METHOD OF FASTENING STRETCHER BAR TO POST**

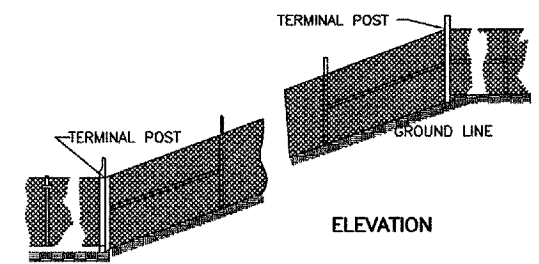

**FENCE INSTALLATION ON SLOPES**

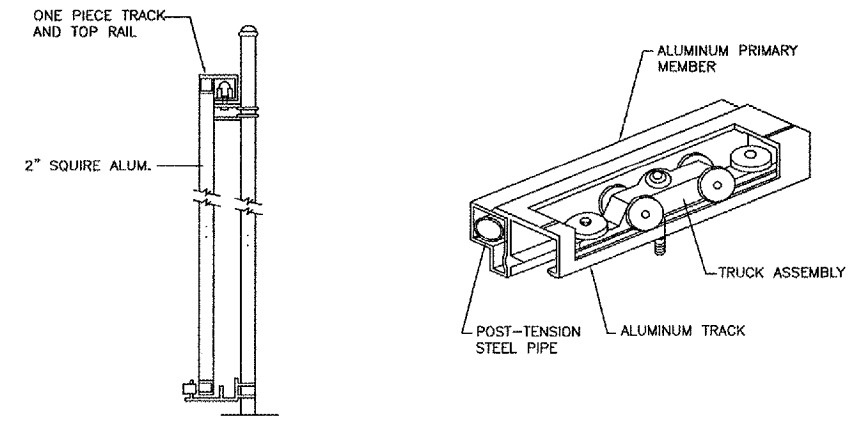

**ROLLER ASSEMBLY FOR SLIDING DRIVEWAY GATE**

NOTE: GATE AND ROLLERS SHALL BE MOUNTED INBOARD  
 CONTRACTOR SHALL SUBMIT SHOP DRAWINGS ENCLOSED  
 TRUCK ROLLER ASSEMBLY FOR SLIDING DRIVEWAY GATES.

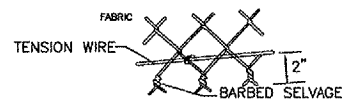

**METHOD OF TYING FABRIC TO TENSION WIRE**

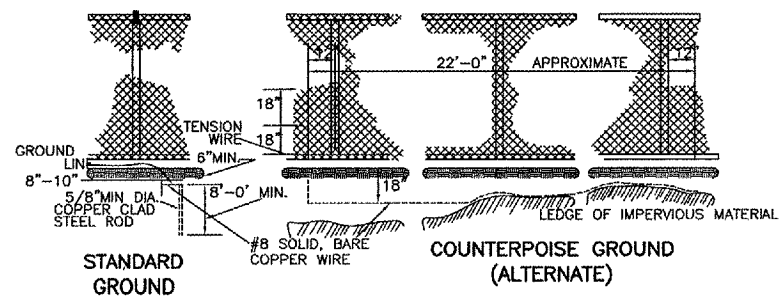

**PROTECTIVE ELECTRICAL GROUND**

**NOTES:**  
 1. CONTINUOUS FENCE SHALL BE GROUNDED AT INTERVALS NOT EXCEEDING 1000' EXCEPT THERE SHALL BE A GROUND NOT EXCEEDING 100 FT. FROM A GATE IN EACH SECTION OF THE FENCE ADJACENT TO THE GATE.  
 2. FENCE UNDER POWER LINE SHALL BE GROUNDED BY THREE GROUNDS, ONE DIRECTLY UNDER THE CROSSING AND ONE ON EACH SIDE 25 TO 50 FT. AWAY. A SINGLE GROUND SHALL BE LOCATED DIRECTLY UNDER EACH TELEPHONE WIRE OR CABLE CROSSING.  
 3. THE COUNTERPOISE SHALL BE USED ONLY WHERE IT IS IMPOSSIBLE TO DRIVE A GROUND ROD BECAUSE OF AN IMPERVIOUS EARTH STRUCTURES.  
 4. THE GROUND WIRE SHALL BE CONNECTED TO FABRIC, TENSION WIRE, AND THE GROUND ROD BY A MECHANICAL CLAMP OF CAST BRONZE BODY AND BRONZE OR STAINLESS STEEL BOLTS AND WASHERS.

**AURORA MUNICIPAL AIRPORT  
 AURORA, ILLINOIS  
 CONSTRUCT RUNWAY 33 ILS,  
 RELOCATE RUNWAY 9 LOCALIZER**

**FENCING DETAILS**

© Copyright Out, Inc.  
**CMT**  
 CRAWFORD, MURPHY & TILLY, INC.  
 CONSULTING ENGINEERS  
 License No. 364-000613

DESIGN BY:	ARM
DRAWN BY:	JRO
CHECKED BY:	CAL
APPROVED BY:	
DATE:	05/12/06
JOB No:	04285-04
ILLINOIS PROJECT: ARR-346B A.I.P. PROJECT: 3-17-0003-B31 <b>FINAL SUBMITTAL</b>	
SHEET 22 OF 67 SHEETS	