

PA050
 K:\Palwaukee\10629007 Extend Txy L\Draw\Sheets\FILE: txy-lighting-3.dwg
 LAYOUT: Layout1
 UPDATE BY: johse
 SURVEY BOOK #
 DATE: Fri 6/30/06 9:32am
 XREF DWG: tbcint.dwg
 tb.dwg
 taxiway-base.dwg

REVISIONS		
NUMBER	BY	DATE

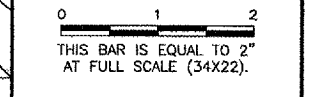

PALWAUKEE MUNICIPAL AIRPORT
WHEELING/PROSPECT HEIGHTS, ILLINOIS
LIGHTING AND PAVEMENT MARKING PLAN
TAXIWAY L
STA. 404+00 TO STA. 418+00

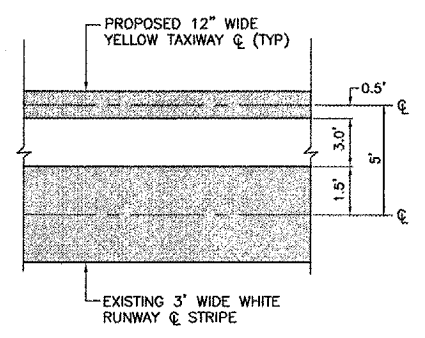

TAXIWAY TANGENT DETAIL
NOT TO SCALE

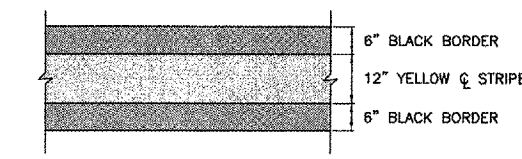

TAXIWAY CENTERLINE ON PCC DETAIL
NOT TO SCALE

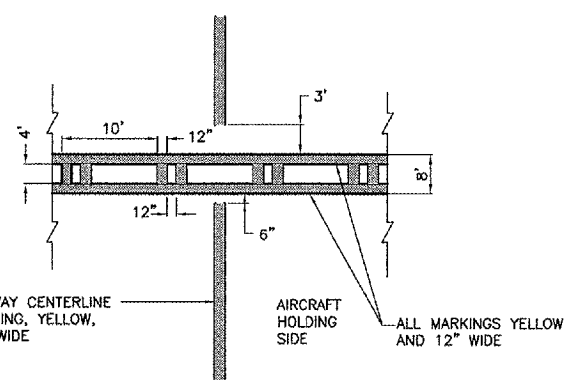

ILS HOLDING POSITION MARKING
NO SCALE

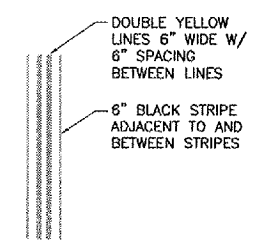

TAXIWAY EDGE MARKINGS CONTINUOUS
NO SCALE

AIRFIELD SIGNAGE SCHEDULE				
NEW SIGN NUMBER	NEW SIGN FACE	NEW SIGN LEGEND	NEW SIGN TYPE	NEW SIGN LOCATION
S1	E W	BLANK	0 3	STA. 195+06.93, 45' LT. ϕ RUNWAY 6/24
S2	E W	16-34	0 1	STA. 197+XX.XX, 45' LT. ϕ RUNWAY 6/24
S3	N S	12-30	1,2 2	STA. 400+99.18, 50' RT. ϕ TAXIWAY L
S4	NW SE	12-30	3,2 2	STA. 808+33.98, 45' RT. ϕ TAXIWAY D
S5	N S	12-30	3,2 2	STA. 403+80.84, 50' RT. ϕ TAXIWAY L
S6	N S	12-30	2 2,1	STA. 406+02.01, 50' LT. ϕ TAXIWAY Y
S7	NW SE	BLANK	0 3	STA. 408+21.39, 75' LT. ϕ RUNWAY 12/30
S8	NW SE	BLANK	3 0	STA. 410+83.76, 75' LT. ϕ RUNWAY 12/30

PAVEMENT MARKING NOTES

- ALL TAXIWAY MARKINGS ARE YELLOW WITH A 6" BLACK BORDER.
- THE PAVEMENT SURFACE SHALL BE CLEAN AND DRY PRIOR TO MARKING.

AIRFIELD SIGNAGE SCHEDULE				
NEW SIGN NUMBER	NEW SIGN FACE	NEW SIGN LEGEND	NEW SIGN TYPE	NEW SIGN LOCATION
S9	NW SE	BLANK	0 3	STA. 410+20.34, 75' RT. ϕ RUNWAY 12/30
S10	NW SE	BLANK	0 3	STA. 412+90.75, 75' RT. ϕ RUNWAY 12/30
S11	N S	12-30	1,2 2	STA. 410+60.06, 50' RT. ϕ TAXIWAY L
S12	N S	12-30	2 3,2,3	STA. 415+18.95, 50' RT. ϕ TAXIWAY L
S13	W E	12-30	2 2,3	STA. 7+25.00, 50' RT. ϕ TAXIWAY L
S14	N S	12-30	2 3,2,3	STA. 17+00.00, 45' LT. ϕ TAXIWAY Y
S15	N S	BLANK	0 2,3	STA. 833+38.22, 50' LT. ϕ TAXIWAY K
S16	E W	12-30	1,2 2	STA. 0+88.00, 50' RT. ϕ TAXIWAY O
S17	N S	12-30	2,3 2	STA. 834+46.14, 50' RT. ϕ TAXIWAY K

NEW SIGN TYPE LEGEND

- 0— BLANK PANEL — BLACK
- 1— RUNWAY/TAXIWAY HOLDLINE — WHITE LEGEND ON RED BACKGROUND
- 2— LOCATION SIGN — YELLOW LEGEND ON BLACK BACKGROUND
- 3— DIRECTION/INFORMATION SIGN — BLACK LEGEND ON YELLOW BACKGROUND

© Copyright CMT, Inc.

CMT
 CRAWFORD, MURPHY & TILLY, INC.
 CONSULTING ENGINEERS
 License No. 184-000613

Palwaukee Municipal Airport

DESIGN BY: MJS
 DRAWN BY: JRO
 CHECKED BY: AB
 APPROVED BY:
 DATE: 06/29/06
 JOB No: 06290-07
 ILLINOIS PROJECT: PWK-3613
 A.I.P. PROJECT: 3-17-0018-B39
 SHEET 27 OF 40 SHEETS