

F.A.J. SHEETS NO.	SECTION	COUNTY	TOTAL SHEETS	SHEET NO.
1587	2004-042 RS	COOK	25	5
STA. N/A	TO STA. N/A			
FED. ROAD DIST. NO. 1	ILLINOIS	FED. AID PROJECT		
CONTRACT NO. 62677				

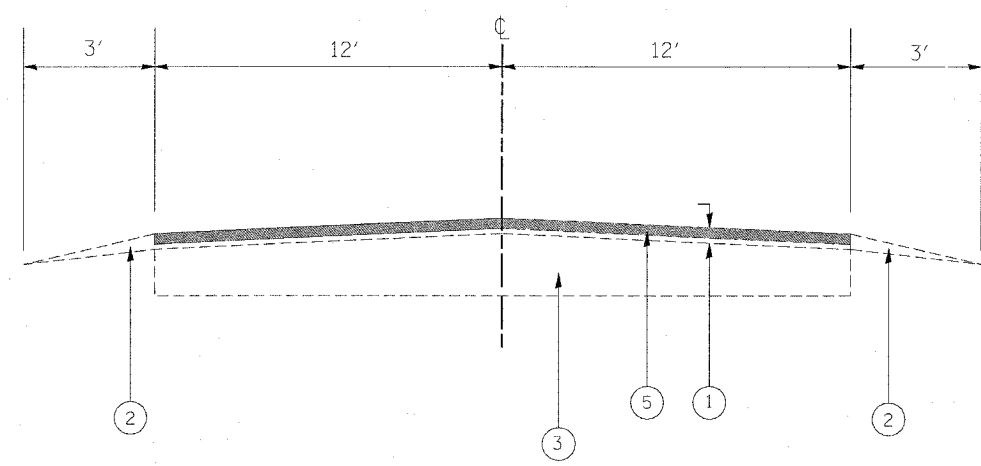

EXISTING TYPICAL CROSS SECTION  
 123rd / 127th STREET  
 STA. 0+00 TO STA. 15+47  
 STA. 24+20 TO STA. 45+25

**LEGEND**

- ① EXISTING BIT. CONC. SURFACE COURSE, ± 8"
- ② EXISTING BIT. AGGREGATE SHOULDER, 3'
- ③ EXISTING SUBBASE GRANULAR MATERIAL, 7"
- ④ PROPOSED AGGREGATE SHOULDER, TYPE B, 3'
- ⑤ PROPOSED BIT. SURFACE REMOVAL (2 1/4")
- ⑥ PROPOSED BIT. CONC. SURFACE COURSE, SUPERPAVE MIX "D", N70 (1 1/2")
- ⑦ PROPOSED POLYMERIZED LEVELING BINDER (MACHINE METHOD), SUPERPAVE, IL-4.75, N50 (3/4")

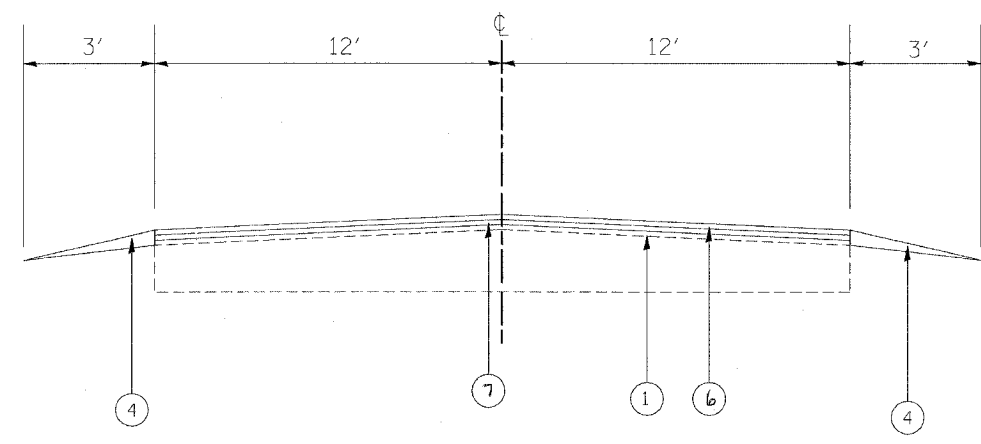

PROPOSED TYPICAL CROSS SECTION  
 123rd / 127th STREET  
 STA. 0+00 TO STA. 15+47  
 STA. 24+20 TO STA. 45+25

**DETAIL: PROPOSED AGGREGATE SHOULDER TYPE B**

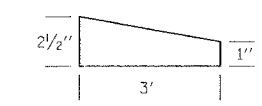

REVISIONS		ILLINOIS DEPARTMENT OF TRANSPORTATION <b>LOCATION #2</b> <b>123RD ST./127TH ST.</b> <b>EXISTING AND PROPOSED</b> <b>TYPICAL SECTION</b>
NAME	DATE	
		SCALE : NONE 3/31/2005 DRAWN BY: MHO CHECKED BY: IR