

F. A. U. RTE.	SECTION	COUNTY	TOTAL SHEETS	SHEET NO.
1587	2004-042 RS	COOK	25	6
STA. N/A	TO STA. N/A			
FED. ROAD DIST. NO. 1	ILLINOIS	FED. AID PROJECT		

CONTRACT NO. 62677

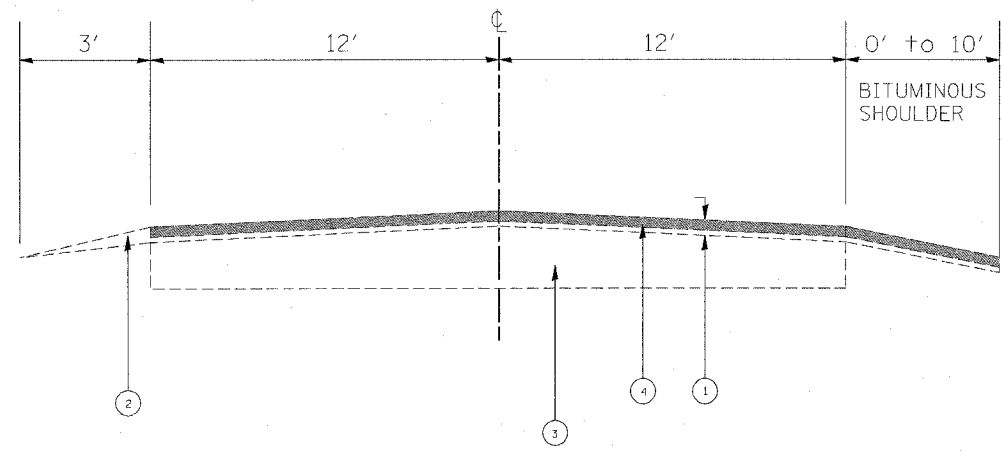

EXISTING TYPICAL CROSS SECTION
123rd / 127th STREET
STA. 15+47 TO STA. 24+20

LEGEND

- ① EXISTING BIT. CONC. SURFACE COURSE, ± 8"
- ② EXISTING BIT. AGGREGATE SHOULDER, 3"
- ③ EXISTING SUBBASE GRANULAR MATERIAL, 7"
- ④ PROPOSED BIT. SURFACE REMOVAL (2 1/4")
- ⑤ PROPOSED BIT. CONC. SURFACE COURSE, SUPERPAVE MIX "D", N70 (1 1/2")
- ⑥ PROPOSED POLYMERIZED LEVELING BINDER (MACHINE METHOD), SUPERPAVE, IL-4.5, N50 (3/4")
- ⑦ PROPOSED AGGREGATE SHOULDER, TYPE B

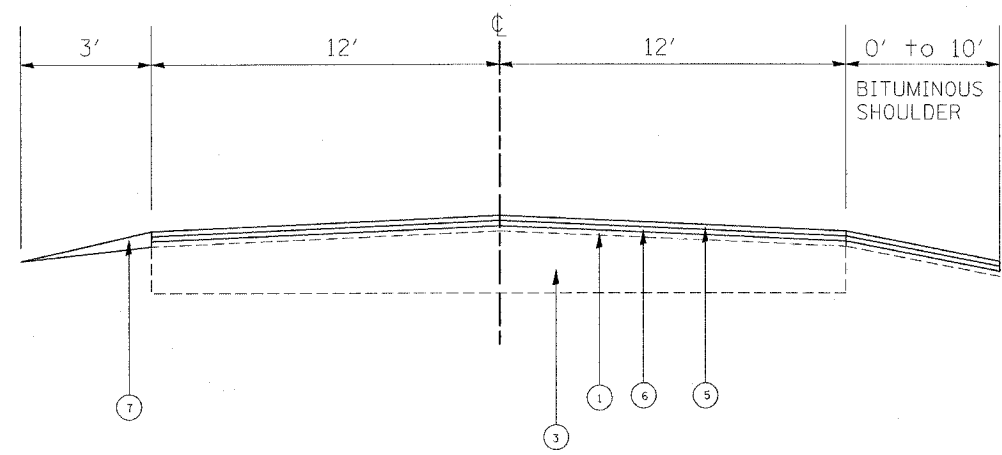

PROPOSED TYPICAL CROSS SECTION
123rd / 127th STREET
STA. 15+47 TO STA. 24+20

REVISIONS	
NAME	DATE

ILLINOIS DEPARTMENT OF TRANSPORTATION
LOCATION #2
123RD ST./127TH ST.
EXISTING AND PROPOSED
TYPICAL SECTIONS

SCALE: VERT. NONE
HORIZ. NONE
DATE 3/31/2005

DRAWN BY: HMO
CHECKED BY: IR