

F.A.P. RTE.	SECTION	COUNTY	TOTAL SHEETS	SHEET NO.
341	2005-015 RS	COOK	18	5
STA. 37+04		TO STA. 41+66		
FED. ROAD DIST. NO. 1		ILLINOIS	FED. AID PROJECT	

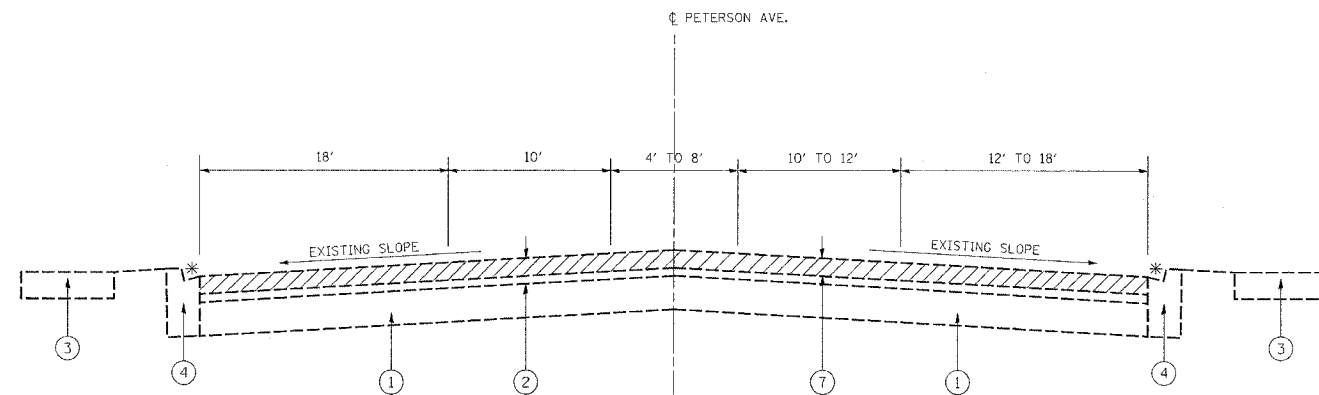

EXISTING TYPICAL SECTION
US 14 (PETERSON AVE.)

STATION
37+04 TO 41+66

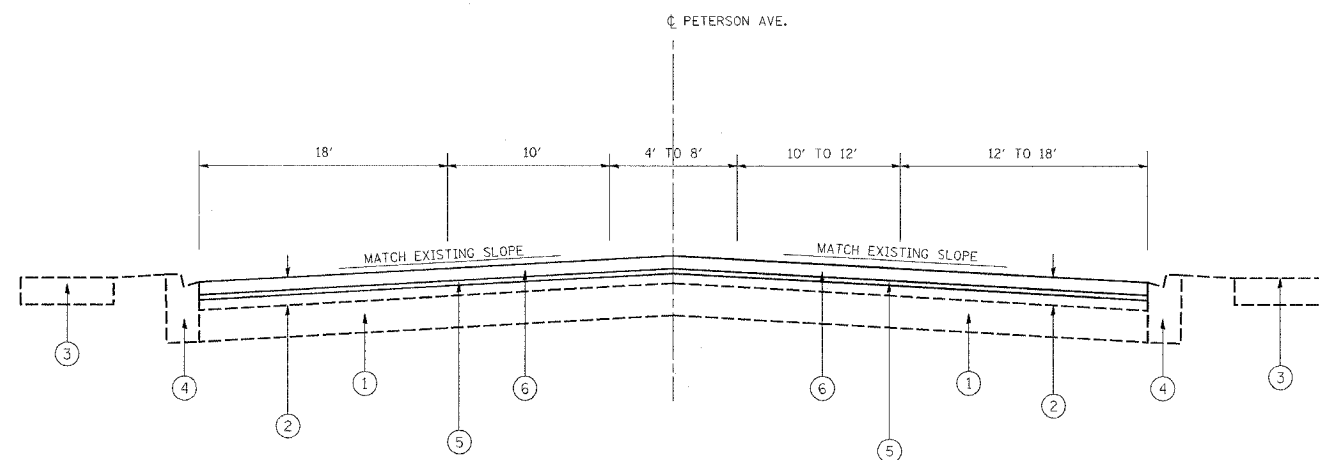

PROPOSED TYPICAL SECTION
US 14 (PETERSON AVE.)

STATION
37+04 TO 41+66

LEGEND

- ① EXISTING PCC BASE COURSE, 10"(\pm)
- ② EXISTING BIT. CONCRETE SURFACE COURSE, 5"(\pm)
- ③ EXISTING PCC SIDEWALK, 5"
- ④ EXISTING COMBINATION CONC. CURB & GUTTER, TYPE B-6.12
- ⑤ PROPOSED POLYMERIZED LEVELING BINDER (MM), SUPERPAVE, IL-4.75, N50, $\frac{3}{4}$ "
- ⑥ PROPOSED BIT. CONC. SURFACE COURSE, SUPERPAVE, MIX "F", N90, $1\frac{3}{4}$ "
- ⑦ BITUMINOUS SURFACE REMOVAL - $2\frac{1}{2}$ "

NOTES:

- ① 4' TO 8' PAINTED MEDIAN FROM STA. 37+04 TO STA. 41+66
- ② EXISTING BRIDGE PIERS FROM (\pm) STA. 40+70 TO STA. 41+51 TO REMAIN
- * ③ BIT. SURFACE REMOVAL (VARIABLE DEPTH OF 0 - $2\frac{1}{2}$ ") AT AREAS WHERE BIT. CONCRETE OVERLAYS GUTTER FLAG. LOCATIONS TO BE DETERMINED IN THE FIELD BY THE RESIDENT ENGINEER.

REVISIONS	
NAME	DATE

ILLINOIS DEPARTMENT OF TRANSPORTATION

TYPICAL SECTIONS

SCALE: VERT.
HORIZ.
DATE

DRAWN BY
CHECKED BY