

TYPICAL MINI-SKIP PAVEMENT MARKINGS

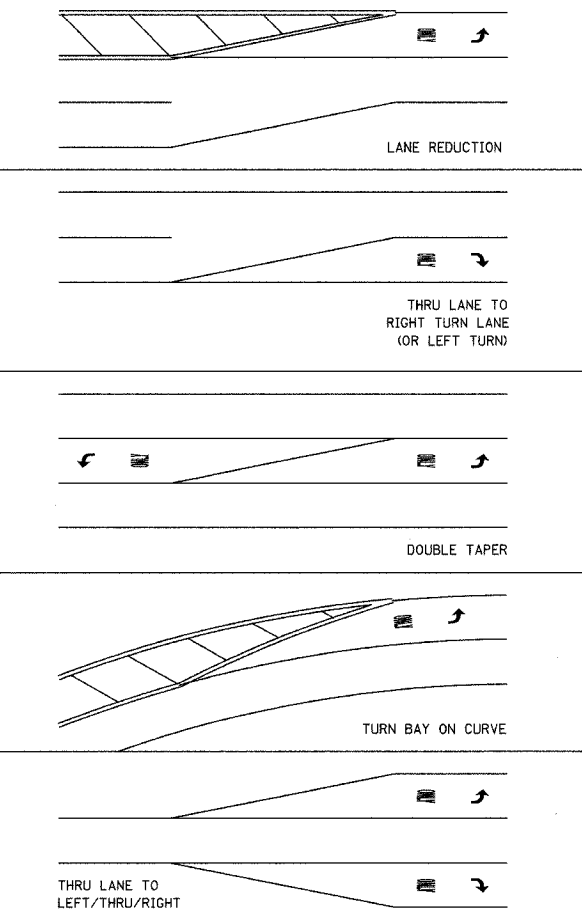

MINI-SKIPS ARE 2 FEET (600mm) WHITE LINE WITH 6 FEET (1.8m) SPACING. THE MINI-SKIP IS THE SAME WIDTH AS THE PAVEMENT MARKING LINE, IT EXTENDS

TYPICAL PAVEMENT MARKINGS

TYPICAL TURN BAY PAVEMENT MARKINGS

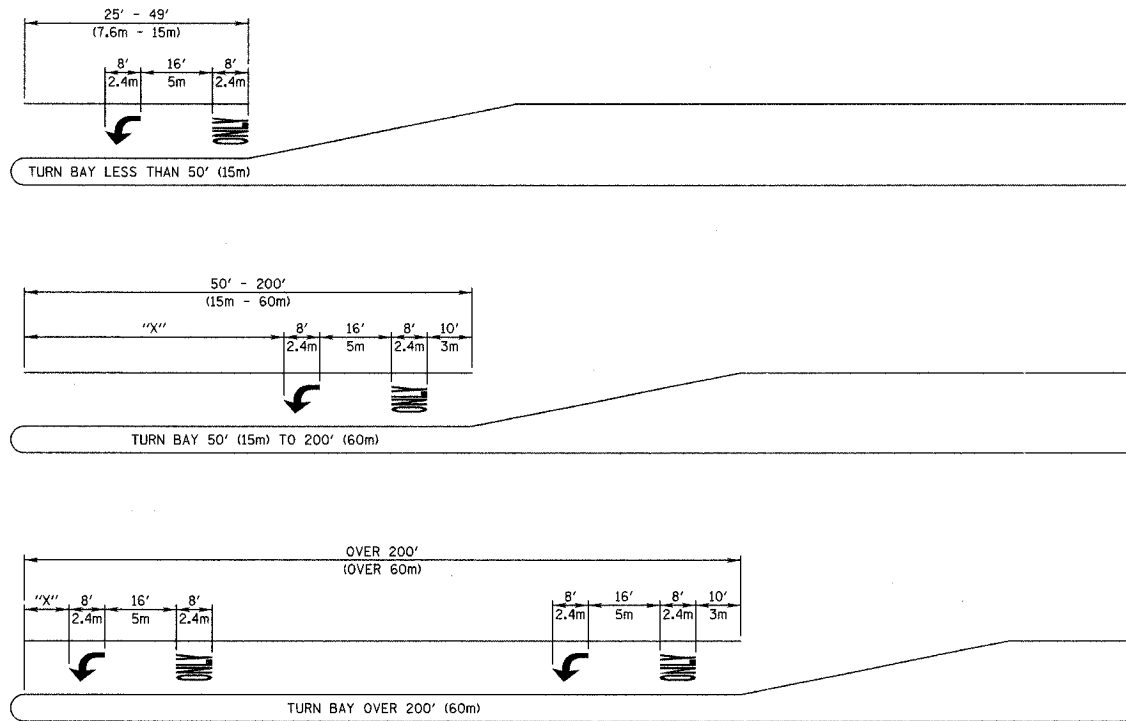

AREA = 15.6 SQ. FT. (1.5 SQ. M) AT INTERSECTIONS WITH VIDEO DETECTION THE DISTANCE "X" SHALL BE A MINIMUM OF 30' (10m). FULL SIZE LETTERS (8' (2.4m)) AND ARROWS SHALL BE USED. TURN LANES IN EXCESS OF 400' (120m) IN LENGTH MAY HAVE AN ADDITIONAL SET OF ARROW W/ "ONLY" INSTALLED MIDWAY BETWEEN THE OTHER TWO SETS OF ARROW W/ "ONLY".

ONLY AREA = 20.8 SQ. FT. (1.9 SQ. M)

ROUTE	SECTION	COUNTY	SHEET	SHEETS
CH	A47	LAKE	176	165
TYPICAL PAVEMENT MARKINGS				
83807 ILLINOIS				

EDGE LINE RADII AT SIDE STREETS

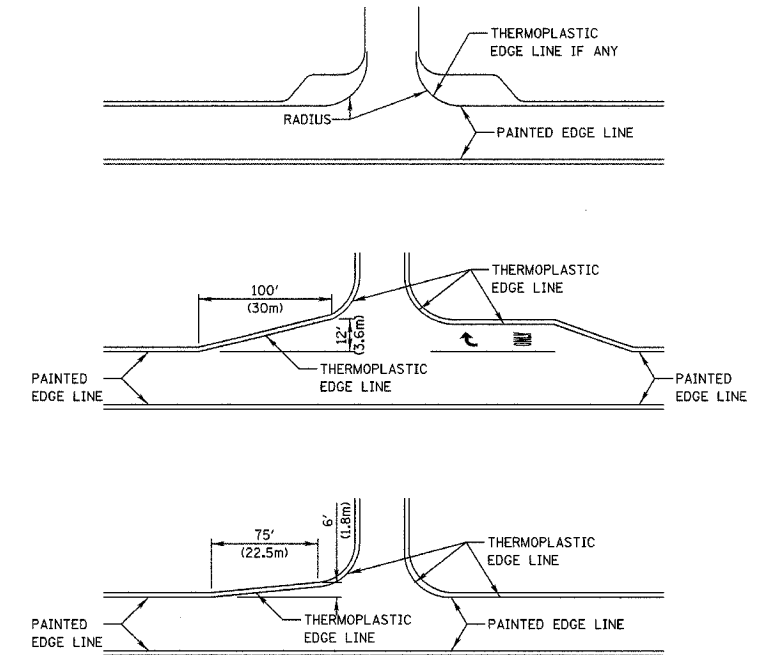

TYPICAL DIAGONAL SPACING

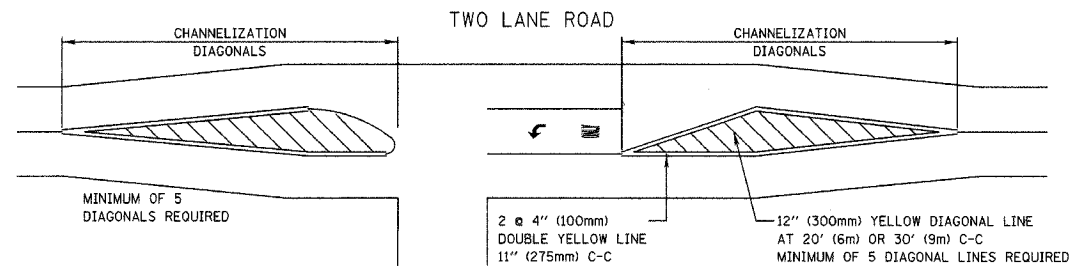

SPEED LIMIT RANGE	DIAGONAL SPACING	
	CONTINUOUS	INTERSECTION CHANNELIZATION
30-45 MPH	75 FT. (20m)	20 FT. (6m)
OVER 45 MPH	150 FT. (45m)	30 FT. (9m)

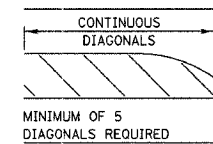

TWO-WAY LEFT TO LEFT TURN BAY

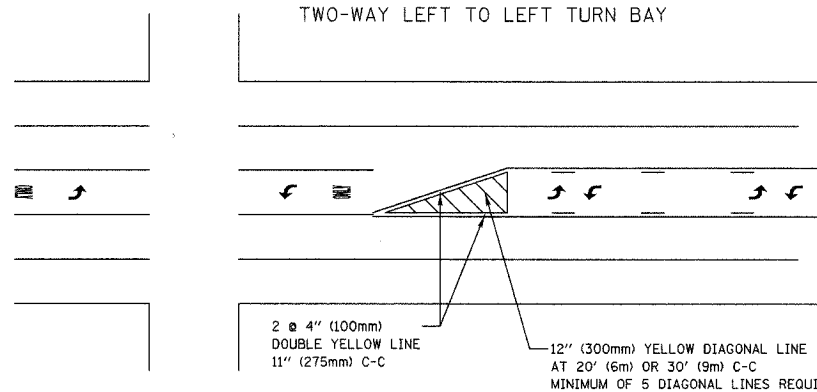

DUAL LEFT TURN ARROWS

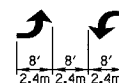

31.2 SQ. FT. (2.94 SQ. M) MIN. OF 2 SETS REQUIRED

A MINIMUM OF TWO PAIRS OF DUAL LEFT TURN ARROWS SHALL BE USED. THE DUAL LEFT TURN ARROWS SHALL BE WHITE IN COLOR. THE INTERVAL BETWEEN SETS OF DUAL LEFT TURN ARROWS SHOULD BE 200' (60 m) AND 300' (90 m).

3 TO 5 LANE ROAD

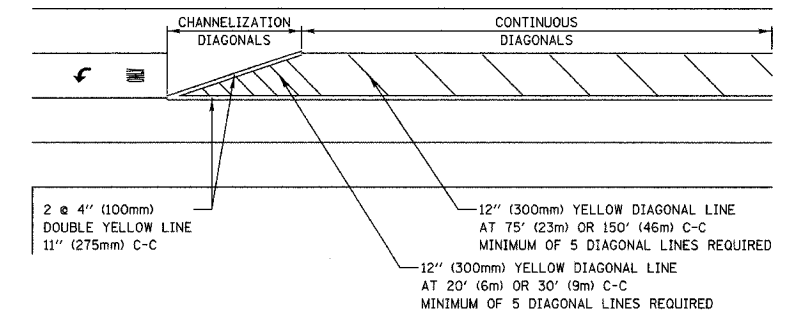

TYPICAL PAVEMENT MARKINGS FOR COUNTY HIGHWAYS

REVISIONS	
NAME	DATE
JOHN SAUTER	7/7/99
JOHN SAUTER	11/01/01

SCALE: NONE SHEET 1 OF 3 DRAWN BY: JPS  
DATE: JAN. 12, 1998 CHECKED BY: ANK