

F.A.U. RTE.	SECTION	COUNTY	TOTAL SHEETS	SHEET NO.
9003	03-00044-00-BR	MADISON	24	3
STA. TO STA.				
FED. ROAD DIST. NO.	ILLINOIS	FED. AID PROJECT		
TYPICAL SECTIONS				
CONTRACT NO. 97256				

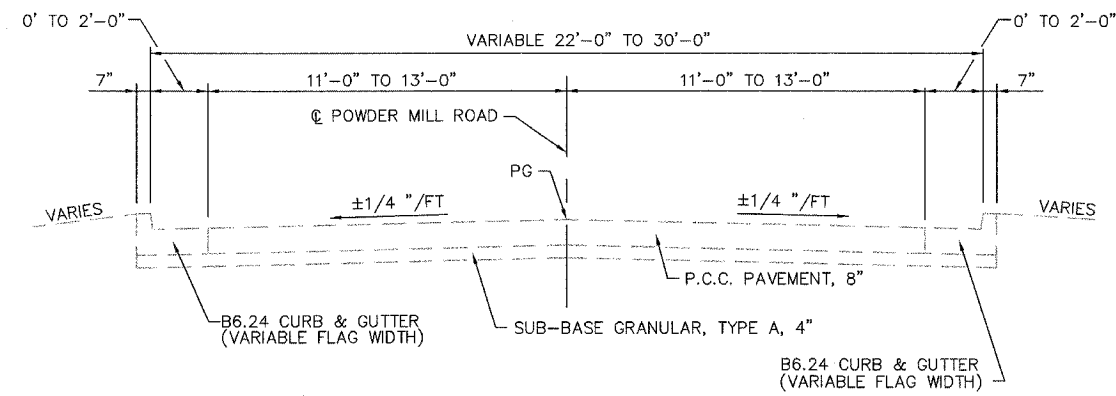

EXISTING TYPICAL SECTION

STA. 11+00 TO STA. 14+50
 BRIDGE OMISSION: STA. 12+09.08 TO STA. 14+10.92

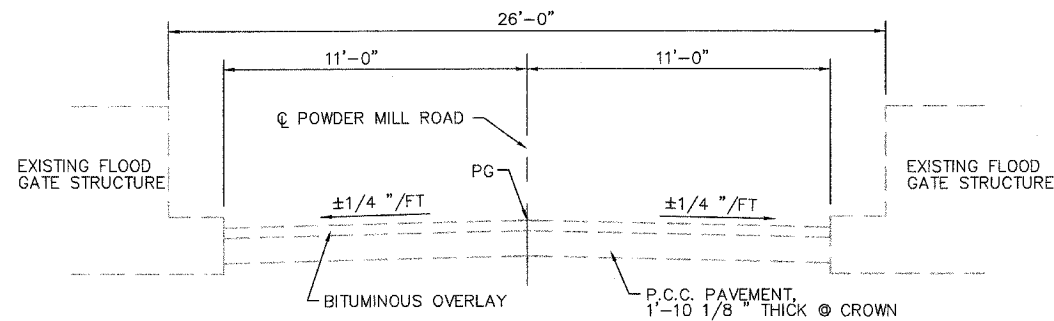

EXISTING TYPICAL SECTION THRU FLOOD GATE STRUCTURE

STA. 14+50 TO STA. 14+73

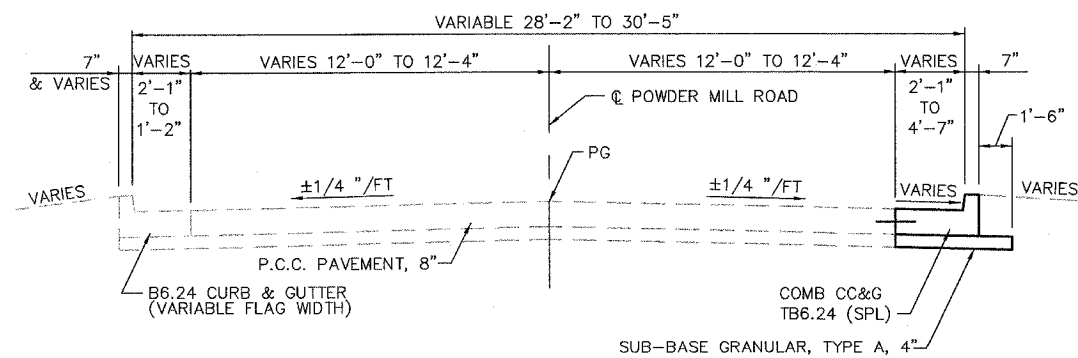

PROPOSED TYPICAL SECTION

STA. 11+50.00 TO STA. 11+83.08

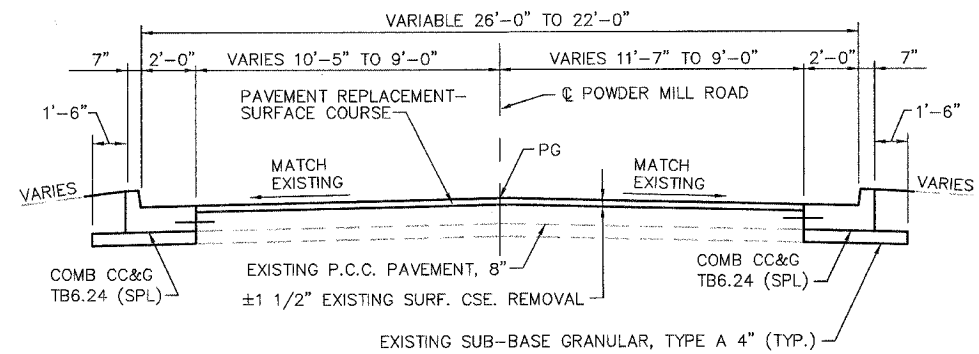

PROPOSED TYPICAL SECTION

STA. 14+31.92 TO STA. 14+50.12

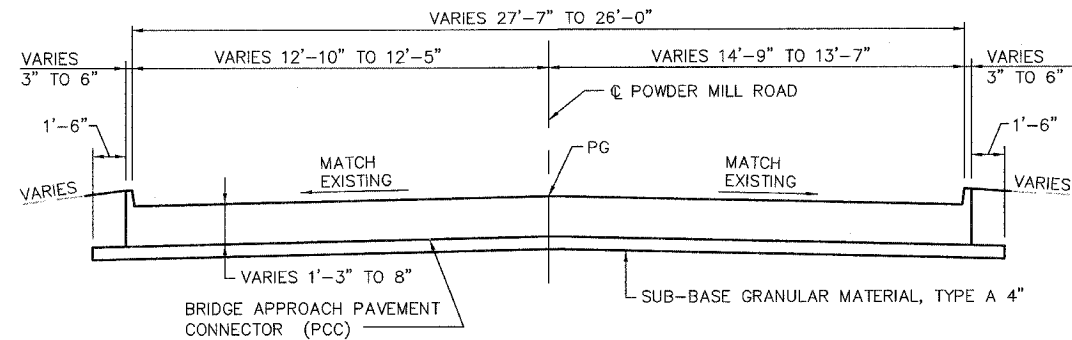

PROPOSED TYPICAL SECTION

PCC CONNECTOR PAVEMENT (SEE STD. 420401)
 STA. 14+25.92 TO STA. 14+31.92

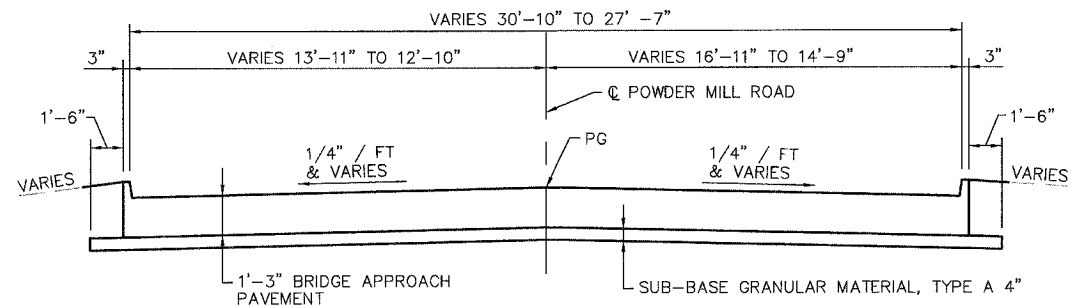

PROPOSED TYPICAL SECTION

(SEE BRIDGE APPROACH PAVEMENT - STD. 420401)
 STA. 11+89.08 TO STA. 12+09.08
 STA. 14+10.92 TO STA. 14+25.92
 BRIDGE OMISSION: STA. 12+09.08 TO STA. 14+10.92

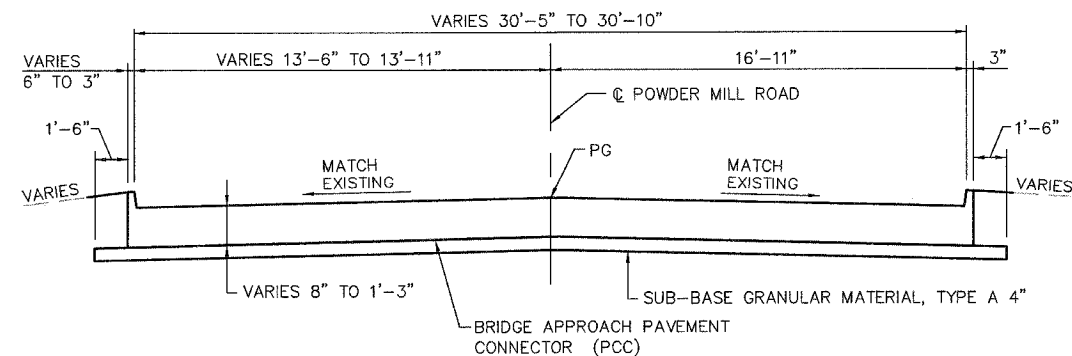

PROPOSED TYPICAL SECTION

PCC CONNECTOR PAVEMENT (SEE STD. 420401)
 STA. 11+83.08 TO STA. 11+89.08