

T-HANGAR FLOOR LAYOUT

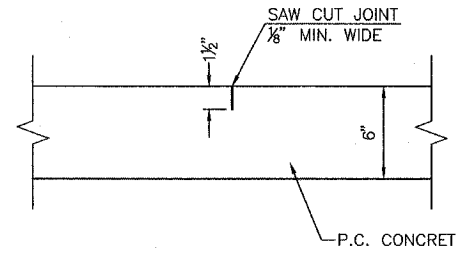

DETAIL OF SAWED CONTRACTION JOINT

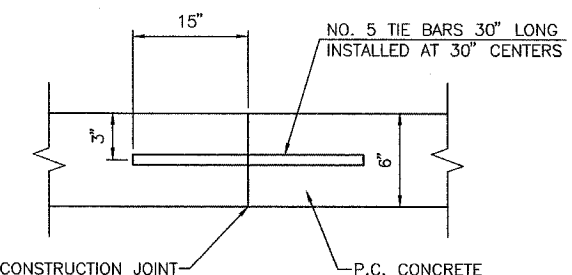

DETAIL OF TIED CONSTRUCTION JOINT

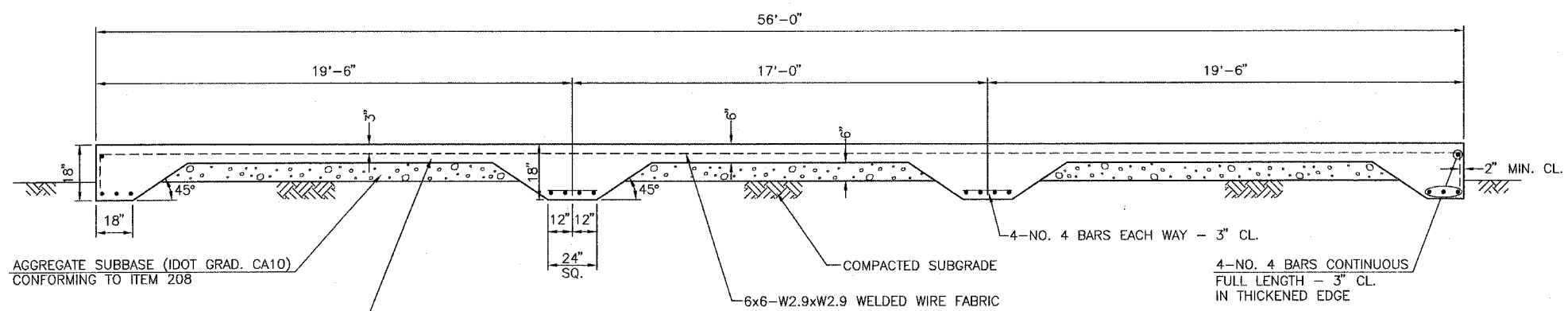

SECTION A-A

PORTLAND CEMENT CONCRETE FLOOR WITH THICKENED EDGE AND INTERIOR PIER PADS POURED MONOLITHICALLY WITH FLOOR (IDOT CLASS SI CONCRETE) CONFORMING TO ITEMS 610 AND AR501200

JACKSONVILLE MUNICIPAL AIRPORT JACKSONVILLE, ILLINOIS	
T-HANGAR FLOOR DETAILS	
HUTCHISON ENGINEERING, INC. JACKSONVILLE, ILLINOIS	
DRAWN BY: T.J.D. DATE: JUNE, 2005	ILL. PROJ. NO. JX-3435 AIP PROJ. NO. 3-17-0054-B10