

MAIN TERMINAL

CONCOURSE

DIRECT CONNECT
 AT EXISTING MANHOLE.
 INV. EL.=742.39

CONNECT LINE A TO LINE B
 WITH 4" NON-PERFORATED
 PIPE - SEE DETAIL "A"

LINE B
 40 L.F. AT 0.5%

LINE A
 260 L.F. AT 0.81%

CAP END
 INV. EL. 746.02

66 L.F. NON-PERFORATED
 OUTLET PIPE AT 2%

400'

90
91
92
93
94

11 12 13 14 15 16 17 18 19 20

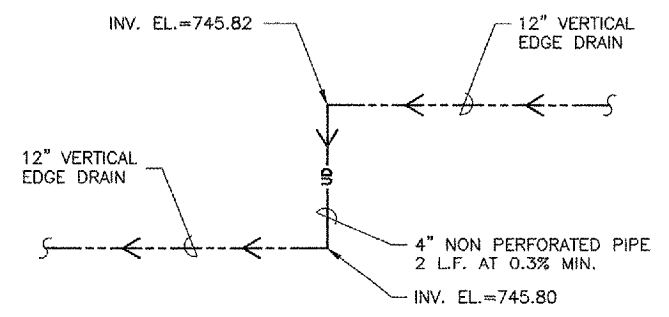

DETAIL A
 N.T.S.

LEGEND

- NEW AR800248 12" VERTICAL EDGE DRAIN
- NEW AR705544 4" NON-PERFORATED UNDERDRAIN PIPE

REVISIONS		
NUMBER	BY	DATE

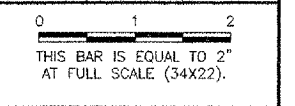

**UNIVERSITY OF ILLINOIS
 WILLARD AIRPORT**

**REHABILITATE AIR CARRIER RAMP
 UNDERDRAIN PLAN**

© Copyright CMT, Inc.
CMT
 CRAWFORD, MURPHY & TILLY, INC.
 CONSULTING ENGINEERS
 License No. 184-000613

DESIGN BY:	SMS
DRAWN BY:	CMT
CHECKED BY:	SMS
APPROVED BY:	
DATE:	06/10/2005
JOB No:	03059-03-00
IL PROJECT:	CM-3449
A.I.P. PROJECT:	3-17-0016-22
SHEET 38 OF 58 SHEETS	