

NOTE:
 WHEN MILLING OPERATIONS PRODUCE A ROUNDED EDGE,
 THEN A SAW CUT SHALL BE USED TO MANUFACTURE
 A PERPENDICULAR EDGE AS SHOWN IN THE DETAIL.
 THE ENGINEER SHALL BE THE SOLE JUDGE
 CONCERNING THE USE OF THIS DETAIL

HMA DETAIL AT BUTT JOINTS

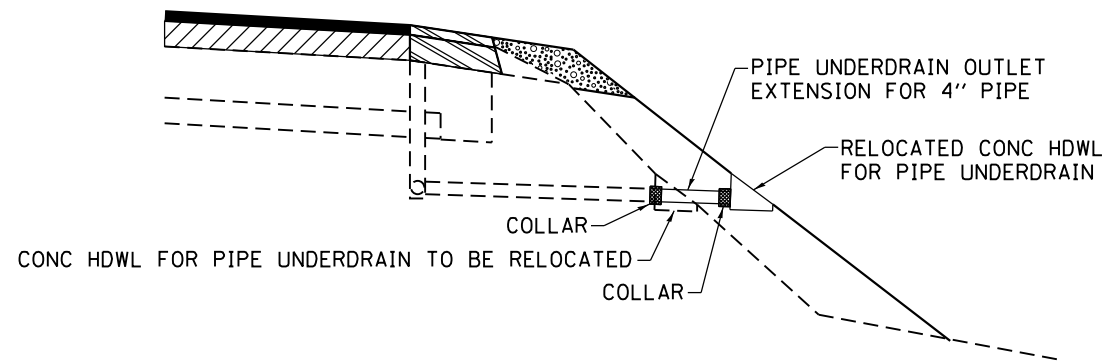

PIPE UNDERDRAIN TO BE FIELD LOCATED BY THE CONTRACTOR AND AS DIRECTED BY THE ENGINEER

PIPE UNDERDRAIN OUTLET EXTENSION FOR 4" PIPE

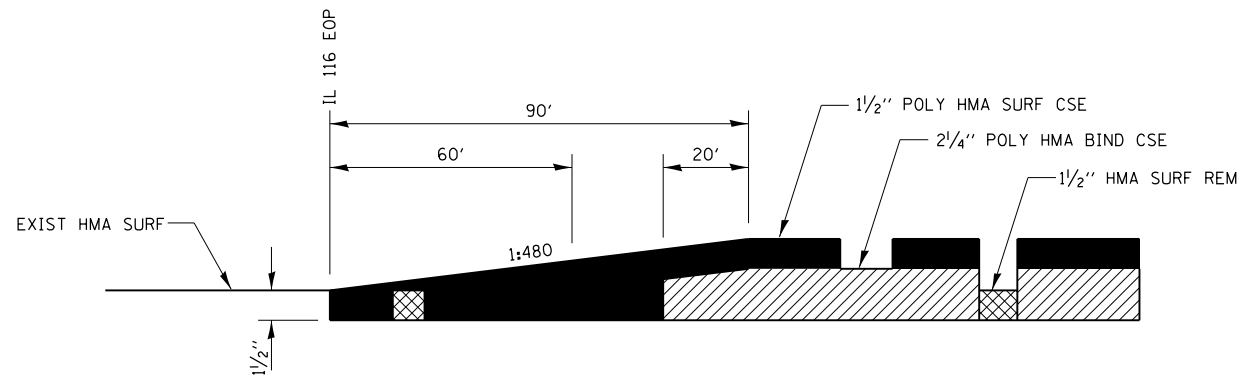

TAPER AT RAMPS

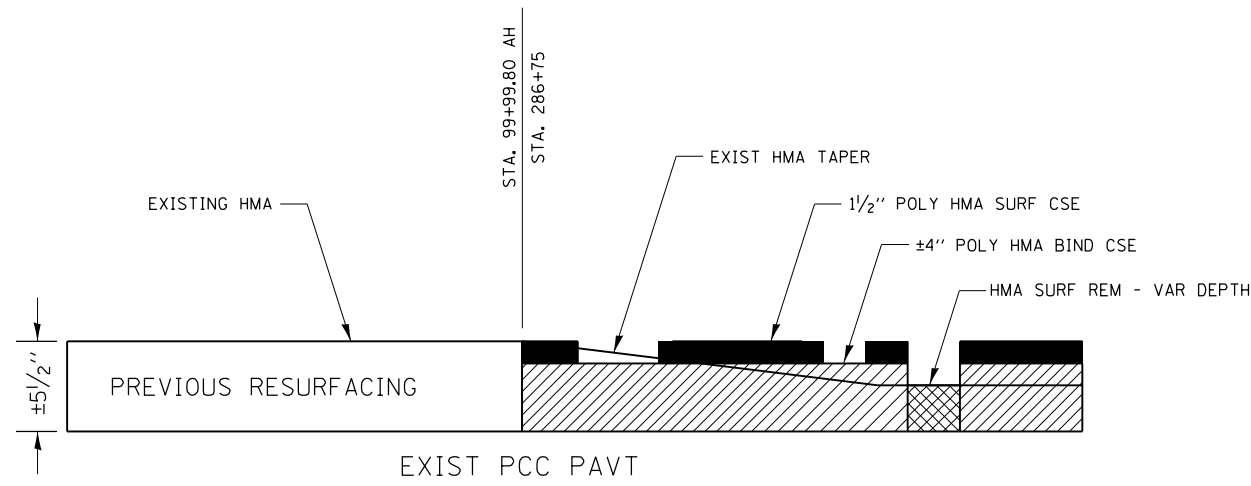

BEGINNING & ENDING TAPERS

FILE NAME =	USER NAME = duncanbd	DESIGNED -	REVISED -
et:\pw\work\p1dot\duncanbd\0315542\0366C53-sht-details.dgn		DRAWN -	REVISED -
		CHECKED -	REVISED -
		DATE -	REVISED -

STATE OF ILLINOIS
 DEPARTMENT OF TRANSPORTATION

DETAILS

SCALE: SHEET NO. OF SHEETS STA. TO STA.

F.A.I. RTE.	SECTION	COUNTY	TOTAL SHEETS	SHEET NO.
57	(38-3)RS-2	IROUOIS	186	45
CONTRACT NO. 66C53				
FED. ROAD DIST. NO. ILLINOIS FED. AID PROJECT				