

STRUCTURE NUMBER		1S0161055R277.0-000	
LOCATION		54A	EXPRESSWAY
SIZE (W x H)	EXIT PLAQUE	-	
	MAIN PANEL	12' X 8'	
MOUNTING / TYPE		OVERHEAD / TRUSS	
MOUNTING LOC (L, M, R)		LEFT	
SHEETING / COLOR	BACKGROUND	TYPE:	ZZ
		COLOR:	GREEN
		TYPE:	
	LEGEND / BORDER	TYPE:	ZZ
		COLOR:	WHITE
		TYPE:	
COLOR:			

**DETAILS**

"TOLL" PLAQUE DETAIL DESIGN

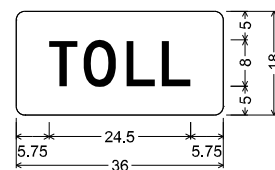

1.50" Radius, 0.00" Border, White on Yellow;  
"TOLL" Black, D 2K;

Table of widths and spaces

5.75	T	4.88	1.13	O	5.63	1.75	L	5.00	1.13	L	5.00	5.75
------	---	------	------	---	------	------	---	------	------	---	------	------

STRUCTURE NUMBER		1S0161055R277.0-000	
LOCATION		54B	EXPRESSWAY
SIZE (W x H)	EXIT PLAQUE	-	
	MAIN PANEL	13' X 12.5'	
MOUNTING / TYPE		OVERHEAD / TRUSS	
MOUNTING LOC (L, M, R)		MIDDLE	
SHEETING / COLOR	BACKGROUND	TYPE:	ZZ
		COLOR:	GREEN
		TYPE:	
	LEGEND / BORDER	TYPE:	ZZ
		COLOR:	WHITE
		TYPE:	
COLOR:			



12.00" Radius, 2.00" Border, White on Green;

"NORTH", E Mod 2K; "Chicago", E Mod 2K;

Table of widths and spaces

16.38	36.00	15.00	N	12.25	3.13	O	10.13	2.88	R	9.75	1.25	T	8.88	2.25	H	9.63	16.50				
22.75	C	12.88	4.50	h	10.63	6.38	i	3.13	5.00	c	10.63	3.50	a	10.50	5.00	g	10.50	5.00	o	10.88	22.75

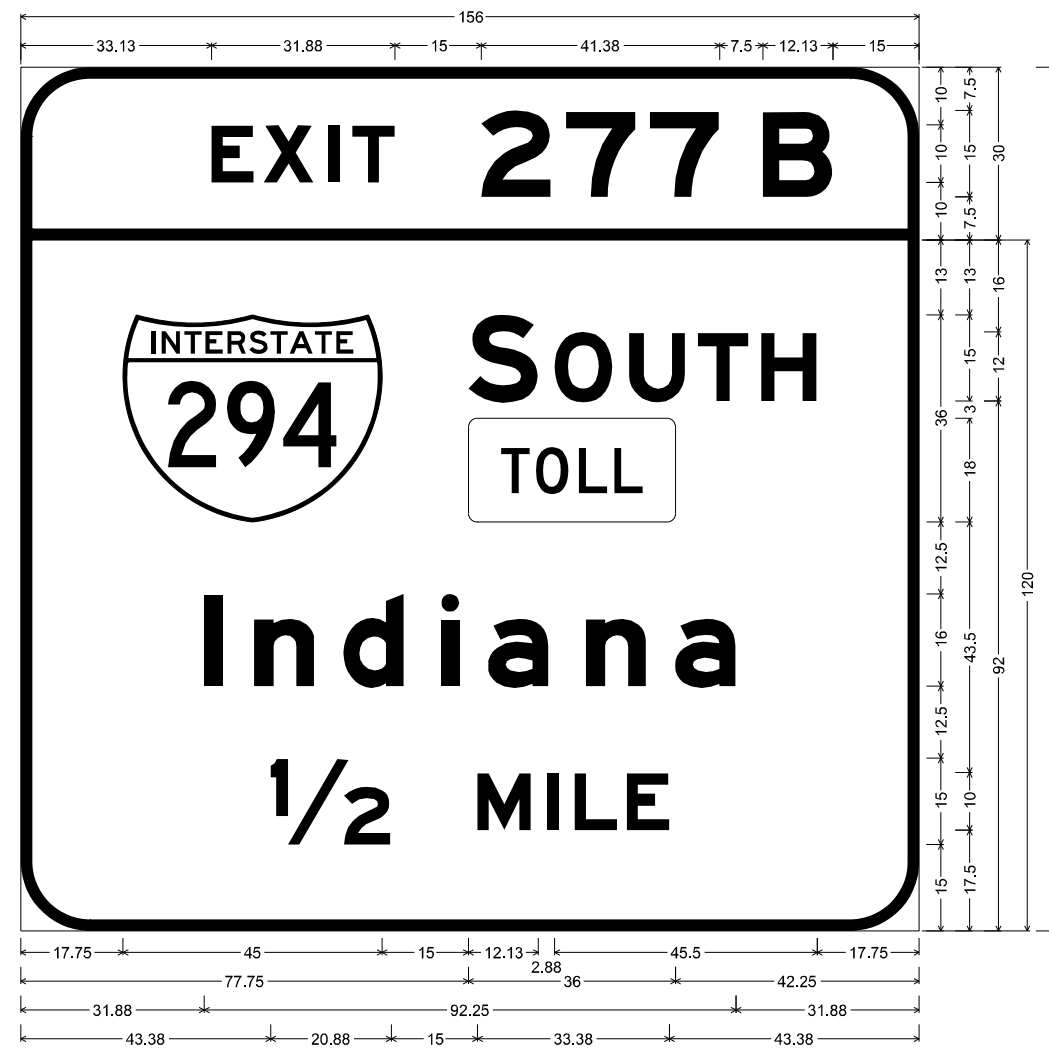

12.00" Radius, 2.00" Border, White on Green;

"EXIT", E Mod 2K 120% spacing; "277", E Mod 2K; "B", E Mod 2K;

12.00" Radius, 2.00" Border, White on Green;

"SOUTH", E Mod 2K; Rounded Rectangle 1.50" Radius Yellow;

"Indiana", E Mod 2K; "1/2 MILE", E Mod 2K;

Table of widths and spaces

33.13	E	7.38	1.63	X	8.75	2.50	I	2.00	2.13	T	7.38	15.00	2	12.25	2.50	7	12.13	2.38	7	12.25	7.50	B	12.13	15.00
17.75	45.00	15.00	S	12.13	2.88	O	10.00	2.88	U	9.75	2.13	8.88	2.13	9.75	17.75									
77.75	36.00	42.25																						
31.88	I	3.13	5.50	n	10.50	5.00	d	10.50	6.50	i	3.13	5.00	a	10.50	6.50	n	10.50	5.00	a	10.50	31.88			
43.38	1/2	20.88	15.00	M	9.38	2.75	I	2.00	2.88	L	7.38	1.63	E	7.38	43.38									

MODEL: D:\p\p\Design\KKS\Signs - Design\Contract-48546-Signs-Structure-Design-155-and-1200-County-4-Line-84-to-Wagon-Road\061927155\_Signs-IP-KK-CO\BIBED-06-28-21.com

USER NAME = plascencjal	DESIGNED - KK	REVISED -
DRAWN - KK / IP	REVISIONS -	
PLOT SCALE = 40,0000 * / in.	CHECKED - LP	REVISED -
PLOT DATE = 7/1/2021	DATE - 06/25/2021	REVISED -

**STATE OF ILLINOIS  
DEPARTMENT OF TRANSPORTATION**

**SIGN PANEL DESIGN**

SCALE: SHEET OF SHEETS STA. TO STA.

F.A.I. RTE.	SECTION	COUNTY	TOTAL SHEETS	SHEET NO.
55	2021-128-SG	VARIOUS	178	101
CONTRACT NO. 62P27				
ILLINOIS FED. AID PROJECT				

STRUCTURE NUMBER		1S016I055R277.0-000	
LOCATION		54C EXPRESSWAY	
SIZE (W x H)	EXIT PLAQUE	-	
	MAIN PANEL	14.5' X 13'	
MOUNTING / TYPE		OVERHEAD / TRUSS	
MOUNTING LOC (L, M, R)		RIGHT	
SHEETING / COLOR	BACKGROUND	TYPE:	ZZ
		COLOR:	GREEN
		TYPE:	
		COLOR:	
	LEGEND / BORDER	TYPE:	ZZ
		COLOR:	WHITE
		TYPE:	
		COLOR:	

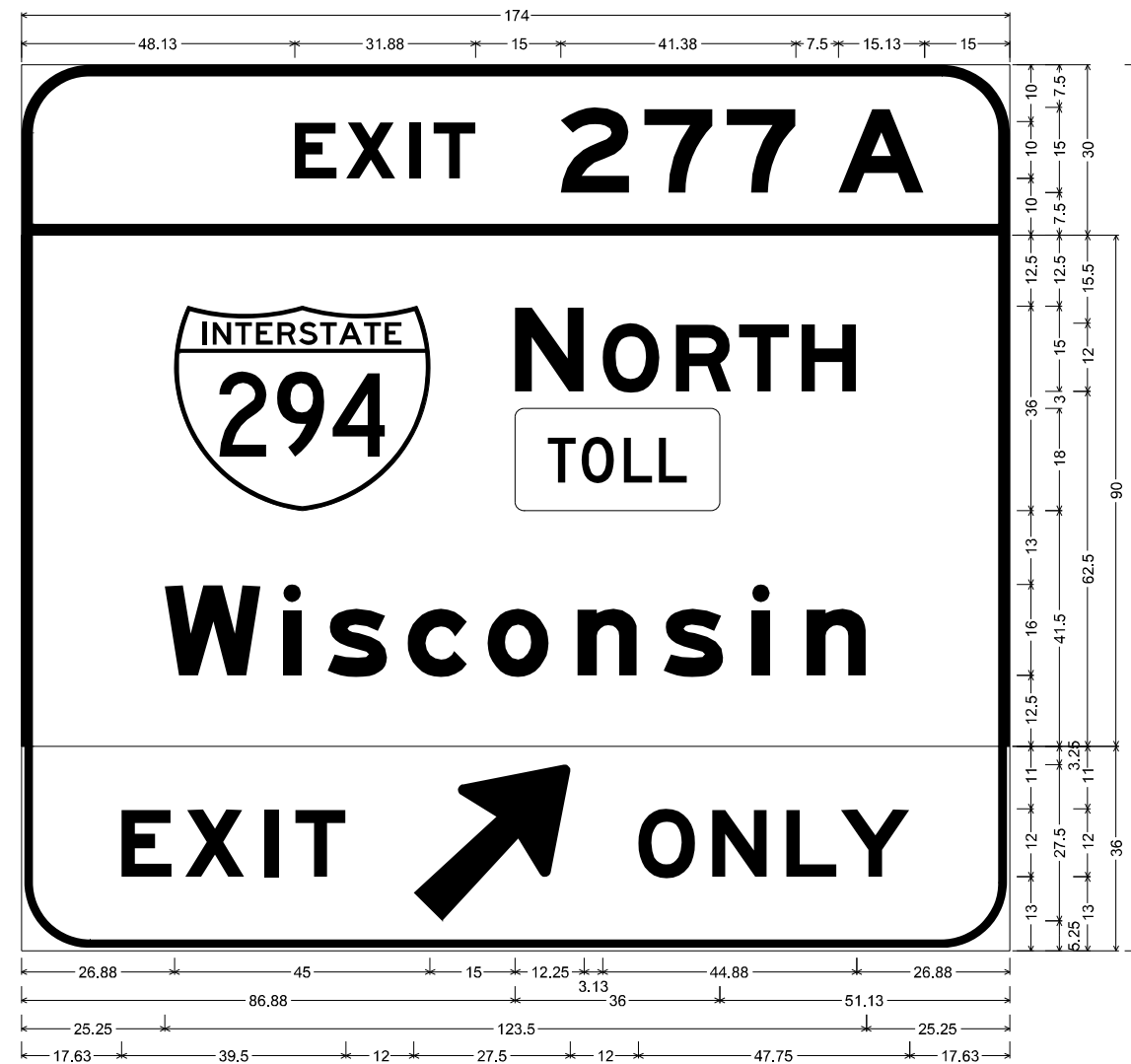

**DETAILS**

"TOLL" PLAQUE DETAIL DESIGN

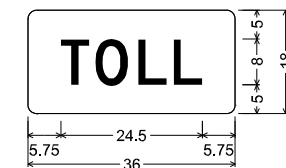

1.50" Radius, 0.00" Border, White on Yellow;  
 "TOLL" Black, D 2K;

Table of widths and spaces

5.75	T	4.88	1.13	O	5.63	1.75	L	5.00	1.13	L	5.00	5.75
------	---	------	------	---	------	------	---	------	------	---	------	------

12.00" Radius, 2.00" Border, White on Green;  
 "EXIT", E Mod 2K 120% spacing; "277", E Mod 2K; "A", E Mod 2K;

12.00" Radius, 2.00" Border, White on Green;  
 "NORTH", E Mod 2K; Rounded Rectangle 1.50" Radius Yellow;  
 "Wisconsin", E Mod 2K;

12.00" Radius, 1.50" Border, 0.50" Indent, Black on Yellow;  
 "EXIT", E Mod 2K specified length; Arrow 160 - 35.00" 45"; "ONLY", E Mod 2K specified length;

Table of widths and spaces

48.13	E	7.38	1.63	X	8.75	2.50	I	2.00	2.13	T	7.38	15.00	2	12.25	2.50	7	12.13	2.38	7	12.25	7.50	A	15.13	15.00			
26.88	294	45.00	15.00	N	12.25	3.13	O	10.13	2.88	R	9.75	1.25	T	8.88	2.25	H	9.63	27.00									
86.88	36.00	51.13																									
25.25	W	17.00	3.75	i	3.25	4.63	s	10.50	3.63	c	10.50	3.50	o	10.88	5.00	n	10.50	4.75	s	10.50	5.00	i	3.13	6.38	n	10.63	25.25
17.63	E	8.88	2.38	X	10.38	3.50	I	2.38	3.13	T	8.88	11.88	27.63	12.00	O	10.00	2.88	N	9.75	3.38	L	8.88	0.75	Y	12.13	17.50	

MODEL: D:\p\h...  
 FILE NAME: S:\IP\Design\KKS\Signs\_Design\Contract-46556-Signs-Structure-Design-155-and-1200-County-4-Inter-84-co-Wiscon-84-co\Wiscor-R01\CDD\62P27-155\_Signs-IP-KK-COMBRED-06-28-21.dwg

USER NAME = plascencjal	DESIGNED - KK	REVISED -
DRAWN - KK / IP	REVISIONS -	
PLOT SCALE = 40,0000 * / in.	CHECKED - LP	REVISED -
PLOT DATE = 7/1/2021	DATE - 06/25/2021	REVISED -

**STATE OF ILLINOIS**  
**DEPARTMENT OF TRANSPORTATION**

<b>SIGN PANEL DESIGN</b>			
SCALE:	SHEET	OF	SHEETS
	STA.		TO STA.

F.A.I. RTE.	SECTION	COUNTY	TOTAL SHEETS	SHEET NO.
55	2021-128-5G	VARIOUS	178	102
CONTRACT NO. 62P27				
ILLINOIS FED. AID PROJECT				



STRUCTURE NUMBER		1S016I055R276.8-000	
LOCATION		55C EXPRESSWAY	
SIZE (W x H)	EXIT PLAQUE	-	
	MAIN PANEL	14.5' X 13'	
MOUNTING / TYPE		OVERHEAD / TRUSS	
MOUNTING LOC (L, M, R)		RIGHT	
SHEETING / COLOR	BACKGROUND	TYPE:	ZZ
		COLOR:	GREEN
		TYPE:	
	LEGEND / BORDER	COLOR:	
		TYPE:	ZZ
		COLOR:	WHITE

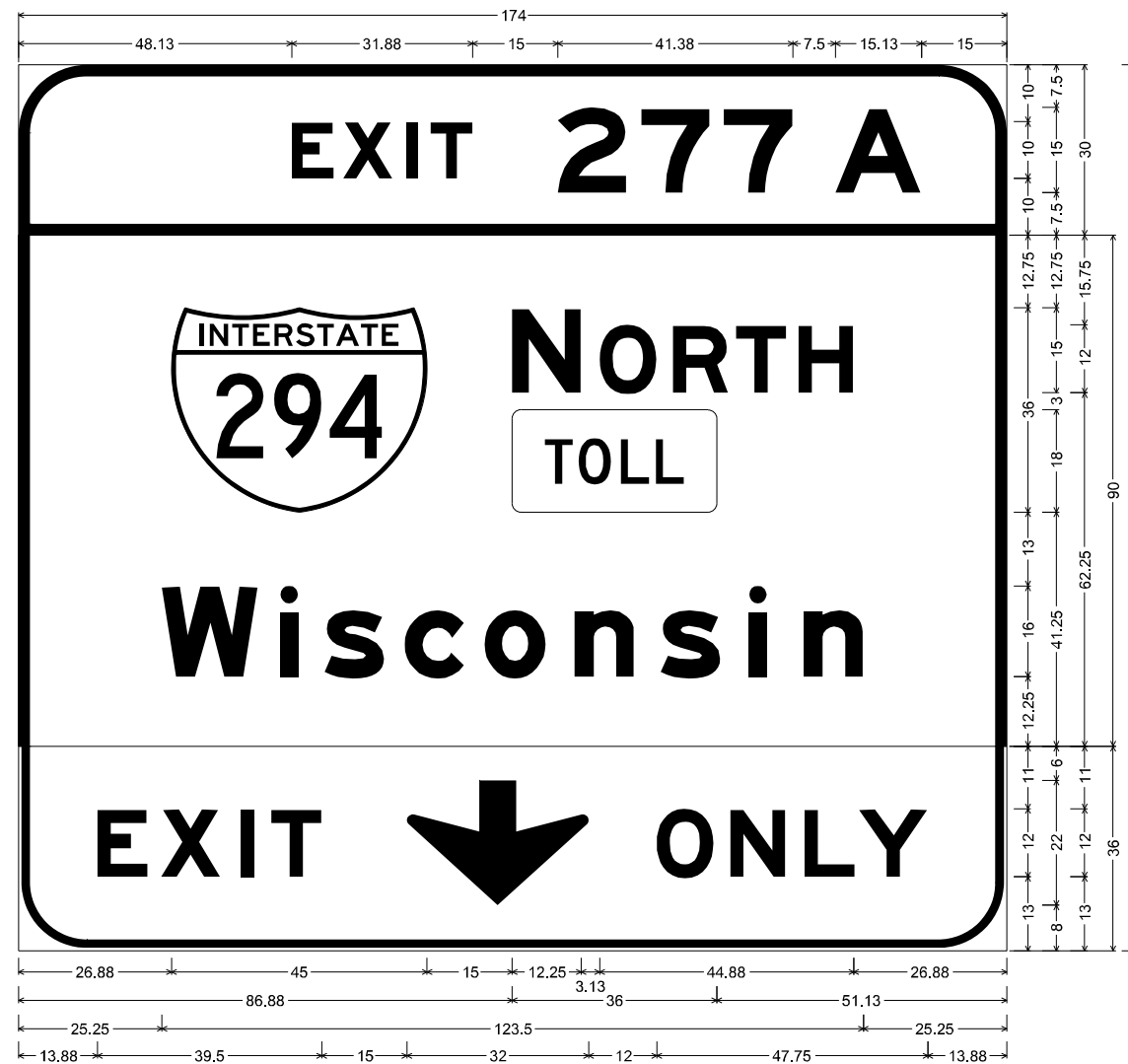

**DETAILS**

"TOLL" PLAQUE DETAIL DESIGN

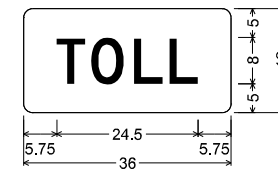

1.50" Radius, 0.00" Border, White on Yellow;  
 "TOLL" Black, D 2K;

Table of widths and spaces

T	O	L	L
5.75	4.88	1.13	5.63
1.75	5.00	1.13	5.00
5.75			

12.00" Radius, 2.00" Border, White on Green;  
 "EXIT", E Mod 2K 120% spacing; "277", E Mod 2K; "A", E Mod 2K;

12.00" Radius, 2.00" Border, White on Green;  
 "NORTH", E Mod 2K; Rounded Rectangle 1.50" Radius Yellow;  
 "Wisconsin", E Mod 2K;

12.00" Radius, 1.50" Border, 0.50" Indent, Black on Yellow;  
 "EXIT", E Mod 2K 140% spacing; Down Arrow 22.00" 270"; "ONLY", E Mod 2K;

Table of widths and spaces

48.13	E	7.38	1.63	X	8.75	2.50	I	2.00	2.13	T	7.38	15.00	2	12.25	2.50	7	12.13	2.38	7	12.25	7.50	A	15.13	15.00			
26.88	294	45.00	15.00	N	12.25	3.13	O	10.13	2.88	R	9.75	1.25	T	8.88	2.25	H	9.63	27.00									
86.88	36.00	51.13																									
25.25	W	17.00	3.75	i	3.25	4.63	s	10.50	3.63	c	10.50	3.50	o	10.88	5.00	n	10.50	4.75	s	10.50	5.00	i	3.13	6.38	n	10.63	25.25
13.88	E	8.88	2.38	X	10.38	3.50	I	2.50	3.00	T	8.88	15.00	↓	32.00	12.00	O	10.00	2.88	N	9.75	3.38	L	8.88	0.75	Y	12.13	13.88

MODEL: D:\p\h...  
 FILE NAME: S:\IP\Design\KKS\Signs\_Design\Contract-46556-Signs-Structure-Design-155-And-1200-County-4-Inter-84-co-Wiscon-84-CDD\62P27-155\_Signs-IP-KK-COMBINED-06-28-21.dwg

USER NAME = plascencjal	DESIGNED - KK	REVISED -
DRAWN - KK / IP	REVISIONS -	
PLOT SCALE = 40,0000 * / in.	CHECKED - LP	REVISED -
PLOT DATE = 7/1/2021	DATE - 06/25/2021	REVISED -

**STATE OF ILLINOIS  
 DEPARTMENT OF TRANSPORTATION**

**SIGN PANEL DESIGN**

SCALE: SHEET OF SHEETS STA. TO STA.

F.A.I. RTE.	SECTION	COUNTY	TOTAL SHEETS	SHEET NO.
55	2021-128-5G	VARIOUS	178	104
CONTRACT NO. 62P27			ILLINOIS FED. AID PROJECT	

DETAILS

"LEFT" PLAQUE DETAIL DESIGN



1.88" Radius, 0.00" Border, White on Yellow; "LEFT" Black, E Mod 2K 125% spacing; Table of widths and spaces

Table of widths and spaces for 'LEFT' plaque with columns L, E, F, T and values 8.88, 2.38, 8.88, 3.13, 8.88, 1.75, 8.88, 8.63

Table with columns: STRUCTURE NUMBER (IS022I055R275. 2-000), LOCATION (57A), EXPRESSWAY, SIZE (W x H), EXIT PLAQUE, MAIN PANEL (13' X 10.5'), MOUNTING / TYPE (OVERHEAD / TRUSS), MOUNTING LOC (L, M, R) (LEFT), SHEETING / COLOR, BACKGROUND, LEGEND / BORDER

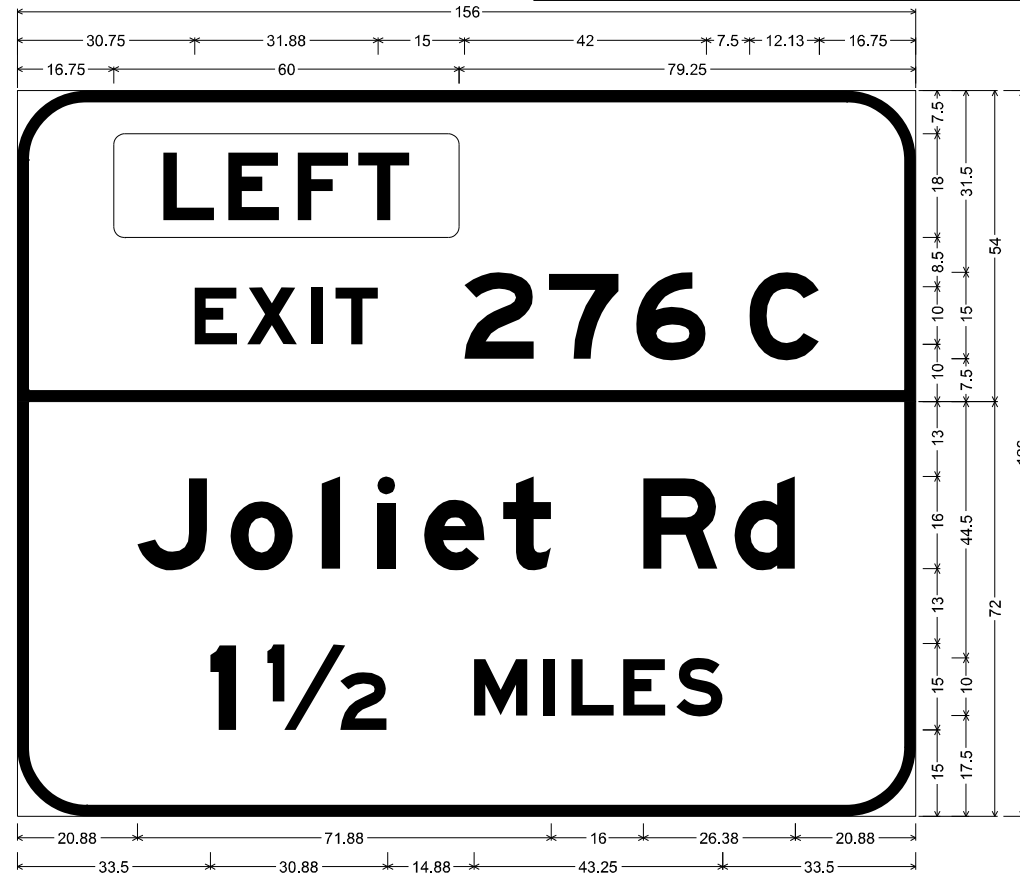

12.00" Radius, 2.00" Border, White on Green; Rounded Rectangle 1.88" Radius Yellow; "EXIT", E Mod 2K 120% spacing; "276", E Mod 2K; "C", E Mod 2K;

12.00" Radius, 2.00" Border, White on Green; "Joliet Rd", E Mod 2K; "1 1/2", E Mod 2K; "MILES", E Mod 2K; Table of widths and spaces

Table of widths and spaces for 'EXIT 276 C' sign with columns for various characters and their widths

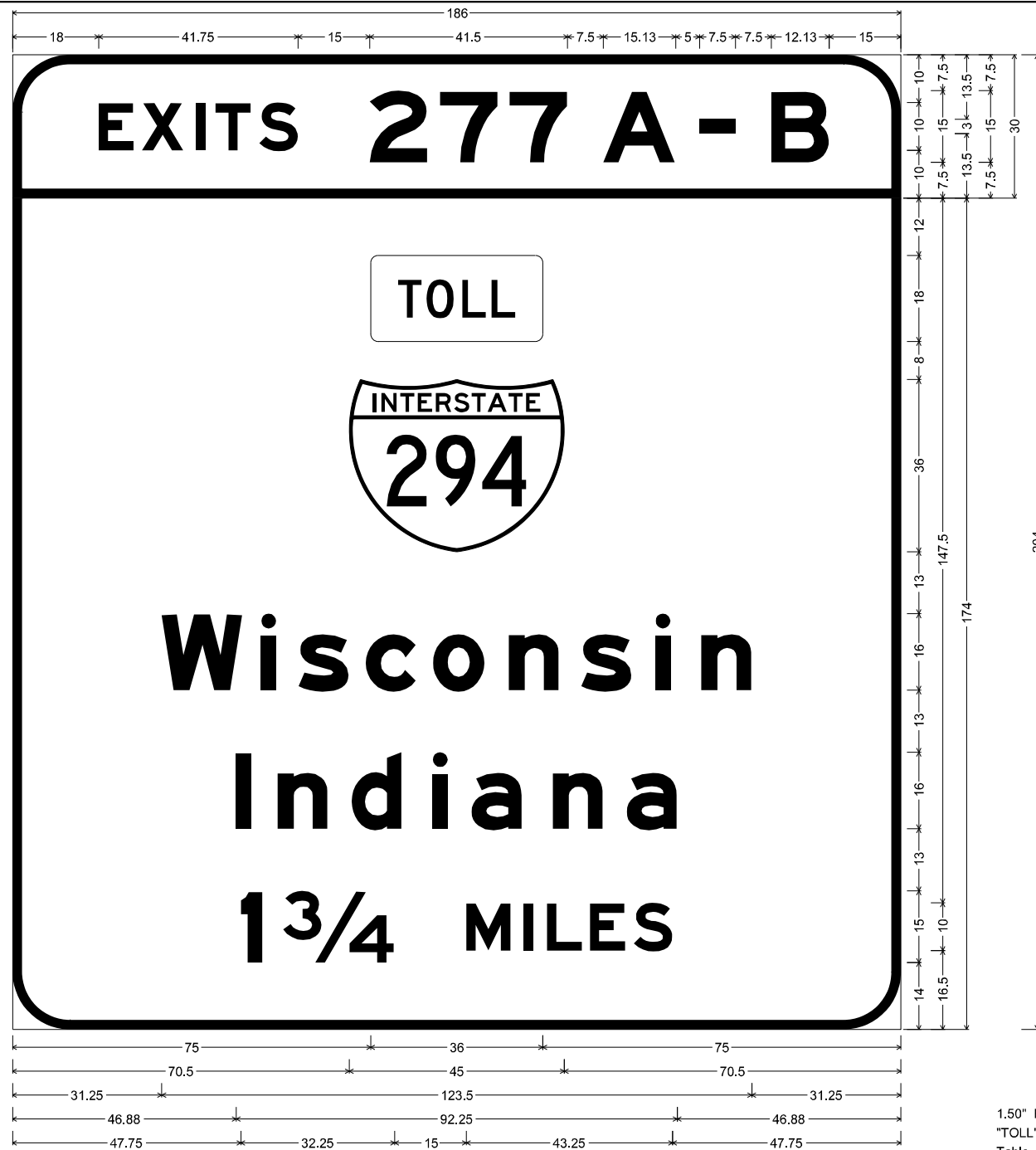

12.00" Radius, 2.00" Border, White on Green; "EXITS", E Mod 2K 120% spacing; "277", E Mod 2K; "A", E Mod 2K; "B", E Mod 2K;

12.00" Radius, 2.00" Border, White on Green; Rounded Rectangle 1.50" Radius Yellow; "Wisconsin", E Mod 2K; "Indiana", E Mod 2K; "1 3/4 MILES", E Mod 2K;

Table of widths and spaces for 'EXITS 277 A-B' sign with columns for various characters and their widths

DETAILS

"TOLL" PLAQUE DETAIL DESIGN

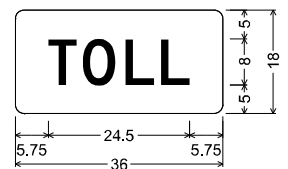

1.50" Radius, 0.00" Border, White on Yellow; "TOLL" Black, D 2K; Table of widths and spaces

Table of widths and spaces for 'TOLL' plaque with columns T, O, L and values 4.88, 1.13, 5.63, 1.75, 5.00, 1.13, 5.00, 5.75

Table with columns: STRUCTURE NUMBER (IS022I055R275. 2-000), LOCATION (57B), EXPRESSWAY, SIZE (W x H), EXIT PLAQUE, MAIN PANEL (15.5' X 17'), MOUNTING / TYPE (OVERHEAD / TRUSS), MOUNTING LOC (L, M, R) (MIDDLE), SHEETING / COLOR, BACKGROUND, LEGEND / BORDER

MODEL: D:\p01\... FILE NAME: SW\IP\Design\KKS\Sigms\_Design\Contract-48556-Sigms\_Structure-Design-L55-Hand-200-County-4-Enc-Rac-to-Wiscon-RI0\CADD\62P27155\_Sigms-IP-RK-COH\BRED-06-28-21.dwg

Table with columns: USER NAME, DESIGNED, REVISED, DRAWN, CHECKED, REVISIONS, PLOT SCALE, PLOT DATE, DATE

STATE OF ILLINOIS DEPARTMENT OF TRANSPORTATION

SIGN PANEL DESIGN

SCALE: SHEET OF SHEETS STA. TO STA.

Table with columns: F.A.I. RTE., SECTION, COUNTY, TOTAL SHEETS, SHEET NO., CONTRACT NO. 62P27, ILLINOIS FED. AID PROJECT

STRUCTURE NUMBER	1S022I055R275.2-000		
LOCATION	57C	EXPRESSWAY	
SIZE (W x H)	EXIT PLAQUE	-	
	MAIN PANEL	19' X 8.5'	
MOUNTING / TYPE	OVERHEAD / TRUSS		
MOUNTING LOC (L, M, R)	RIGHT		
SHEETING / COLOR	BACKGROUND	TYPE:	ZZ
		COLOR:	GREEN
		TYPE:	
	LEGEND / BORDER	COLOR:	
		TYPE:	ZZ
		COLOR:	WHITE
		TYPE:	
		COLOR:	

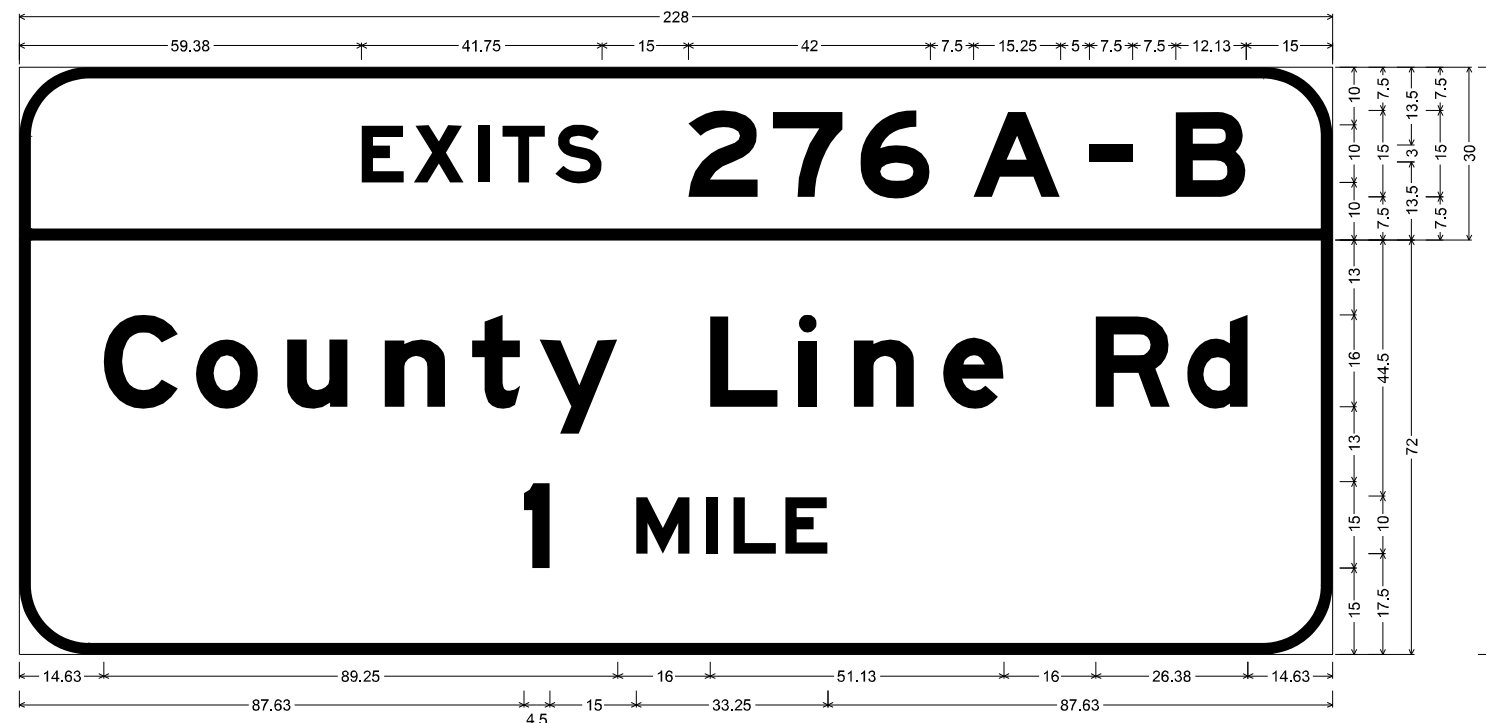

12.00" Radius, 2.00" Border, White on Green;  
 "EXITS", E Mod 2K 120% spacing; "276", E Mod 2K; "A", E Mod 2K; "B", E Mod 2K;

12.00" Radius, 2.00" Border, White on Green;  
 "County Line Rd", E Mod 2K; "1 MILE", E Mod 2K;

Table of widths and spaces

59.38	E	X	I	T	S	2	7	6	A		B	15.00											
7.50	1.63	8.75	2.50	2.00	2.13	7.38	1.75	8.13	15.00	12.13	2.63	12.13	3.00	12.13	7.50	15.13	5.00	7.50	7.50	12.25	15.00		
14.63	C	O	U	N	T	Y	L	I	N	E	R	D	14.75										
14.63	3.00	10.88	5.00	10.50	6.38	10.63	4.63	8.25	3.38	13.63	16.00	11.88	3.50	3.25	6.38	10.50	5.00	10.50	16.00	13.00	2.88	10.50	14.75
87.63	1	M	I	L	E	87.63																	
87.63	4.50	15.00	9.25	2.88	2.00	2.75	7.38	1.63	7.38	87.63													

MODEL: D:\p1\...  
 FILE NAME: ...  
 USER: ...  
 DATE: ...

USER NAME = plascencjal	DESIGNED - KK	REVISED -
DRAWN - KK / IP	REVISOR -	
PLOT SCALE = 40,0000 * / in.	CHECKED - LP	REVISOR -
PLOT DATE = 7/1/2021	DATE - 06/25/2021	REVISOR -

**STATE OF ILLINOIS  
 DEPARTMENT OF TRANSPORTATION**

**SIGN PANEL DESIGN**

SCALE: SHEET OF SHEETS STA. TO STA.

F.A.I. RTE.	SECTION	COUNTY	TOTAL SHEETS	SHEET NO.
55	2021-128-SG	VARIOUS	178	106
			CONTRACT NO. 62P27	
ILLINOIS FED. AID PROJECT				

STRUCTURE NUMBER		1C022I055R274.5-000	
LOCATION		58 EXPRESSWAY	
SIZE (W x H)	EXIT PLAQUE	-	
	MAIN PANEL	18' X 10'	
MOUNTING / TYPE		OVERHEAD / CANTILEVER	
MOUNTING LOC (L, M, R)			
SHEETING / COLOR	BACKGROUND	TYPE:	ZZ
		COLOR:	GREEN
		TYPE:	
	LEGEND / BORDER	COLOR:	
		TYPE:	ZZ
		COLOR:	WHITE

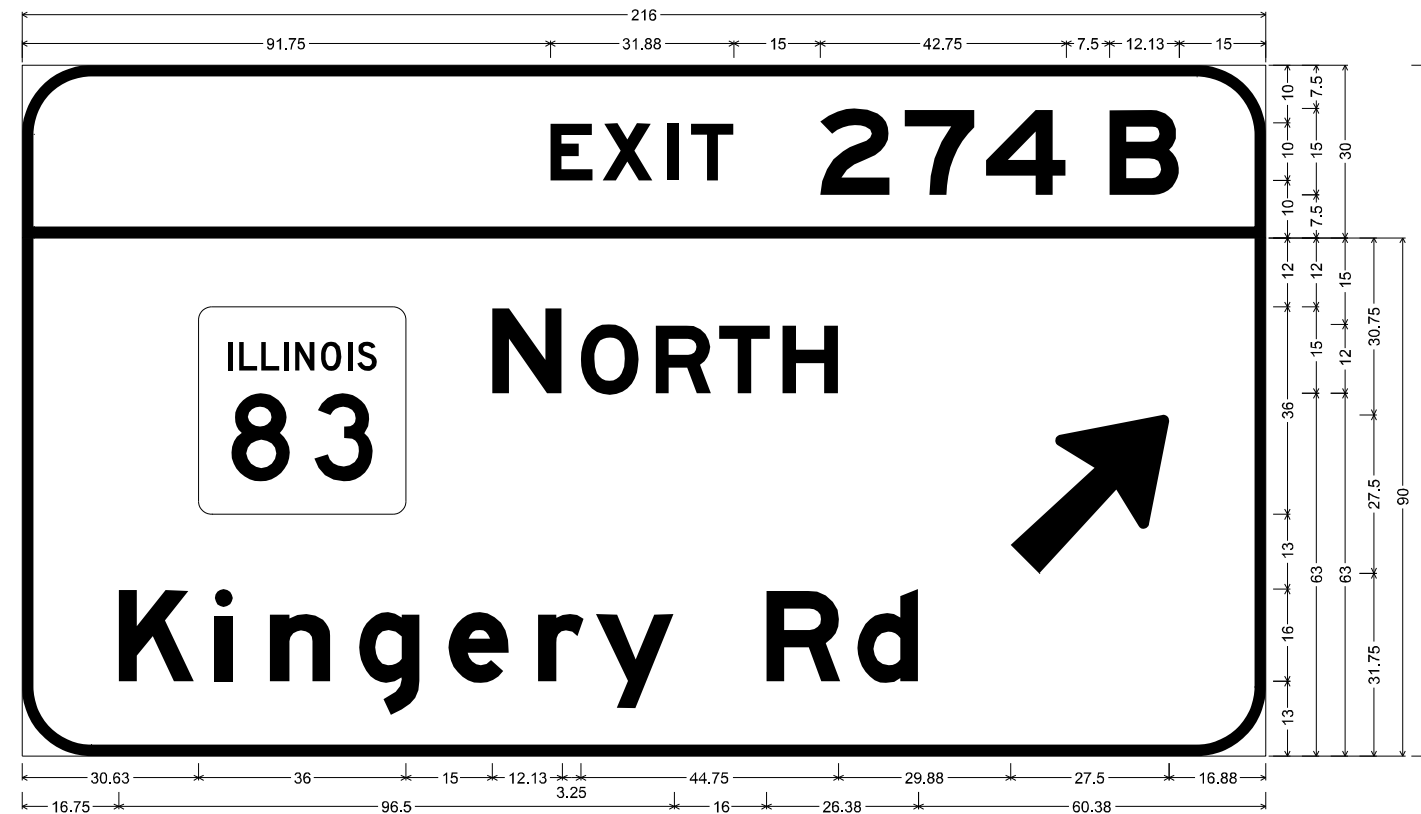

12.00" Radius, 2.00" Border, White on Green;  
 "EXIT", E Mod 2K 120% spacing; "274", E Mod 2K; "B", E Mod 2K;  
 12.00" Radius, 2.00" Border, White on Green;  
 "NORTH", E Mod 2K; "Kingery Rd", E Mod 2K; Arrow 160 - 35.00" 45°;

Table of widths and spaces

91.75	E	7.38	1.75	X	8.63	2.50	I	2.00	2.25	T	7.38	15.00	Z	12.13	2.50	7	12.13	2.00	4	14.00	7.50	B	12.13	15.00			
30.63	63	36.00	15.00	N	12.13	3.25	O	10.13	2.88	R	9.75	1.25	T	8.88	2.25	H	9.63	29.88	27.50	16.88							
16.75	K	13.13	3.50	i	3.25	6.38	n	10.63	4.88	g	10.63	4.88	e	10.63	5.00	r	8.00	2.00	y	13.63	16.00	R	13.00	2.88	d	10.50	60.38

MODEL: D:\p\h  
 FILE NAME: S:\IP\Design\KKS\Signs Design\Contract-46556-Signs-Structure-Design-155-and-1200-County-4-Enc-84-co-Water-Rd\CADD\62P27455\_Signs-IP-KK-COMBINED-06-28-21.dwg

USER NAME = plascenciaj	DESIGNED - KK	REVISED -
DRAWN - KK / IP	REVISIONS -	
PLOT SCALE = 40,0000 * / in.	CHECKED - LP	REVISED -
PLOT DATE = 7/1/2021	DATE - 06/25/2021	REVISED -

**STATE OF ILLINOIS**  
**DEPARTMENT OF TRANSPORTATION**

<b>SIGN PANEL DESIGN</b>			
SCALE:	SHEET	OF	SHEETS
	STA.		TO STA.

F.A.I. RTE.	SECTION	COUNTY	TOTAL SHEETS	SHEET NO.
55	2021-128-SG	VARIOUS	178	107
			CONTRACT NO. 62P27	
		ILLINOIS	FED. AID PROJECT	

STRUCTURE NUMBER		1S0221055R274.4-000
LOCATION		60A EXPRESSWAY
SIZE (W x H)	EXIT PLAQUE	-
	MAIN PANEL	14' X 12.5'
MOUNTING / TYPE		OVERHEAD / TRUSS
MOUNTING LOC (L, M, R)		LEFT
SHEETING / COLOR	BACKGROUND	TYPE: ZZ
		COLOR: GREEN
		TYPE:
	LEGEND / BORDER	TYPE: ZZ
		COLOR: WHITE
		TYPE:
COLOR:		

STRUCTURE NUMBER		1S0221055R274.4-000
LOCATION		60B EXPRESSWAY
SIZE (W x H)	EXIT PLAQUE	-
	MAIN PANEL	18' X 10.5'
MOUNTING / TYPE		OVERHEAD / TRUSS
MOUNTING LOC (L, M, R)		RIGHT
SHEETING / COLOR	BACKGROUND	TYPE: ZZ
		COLOR: GREEN
		TYPE:
	LEGEND / BORDER	TYPE: ZZ
		COLOR: WHITE
		TYPE:
COLOR:		

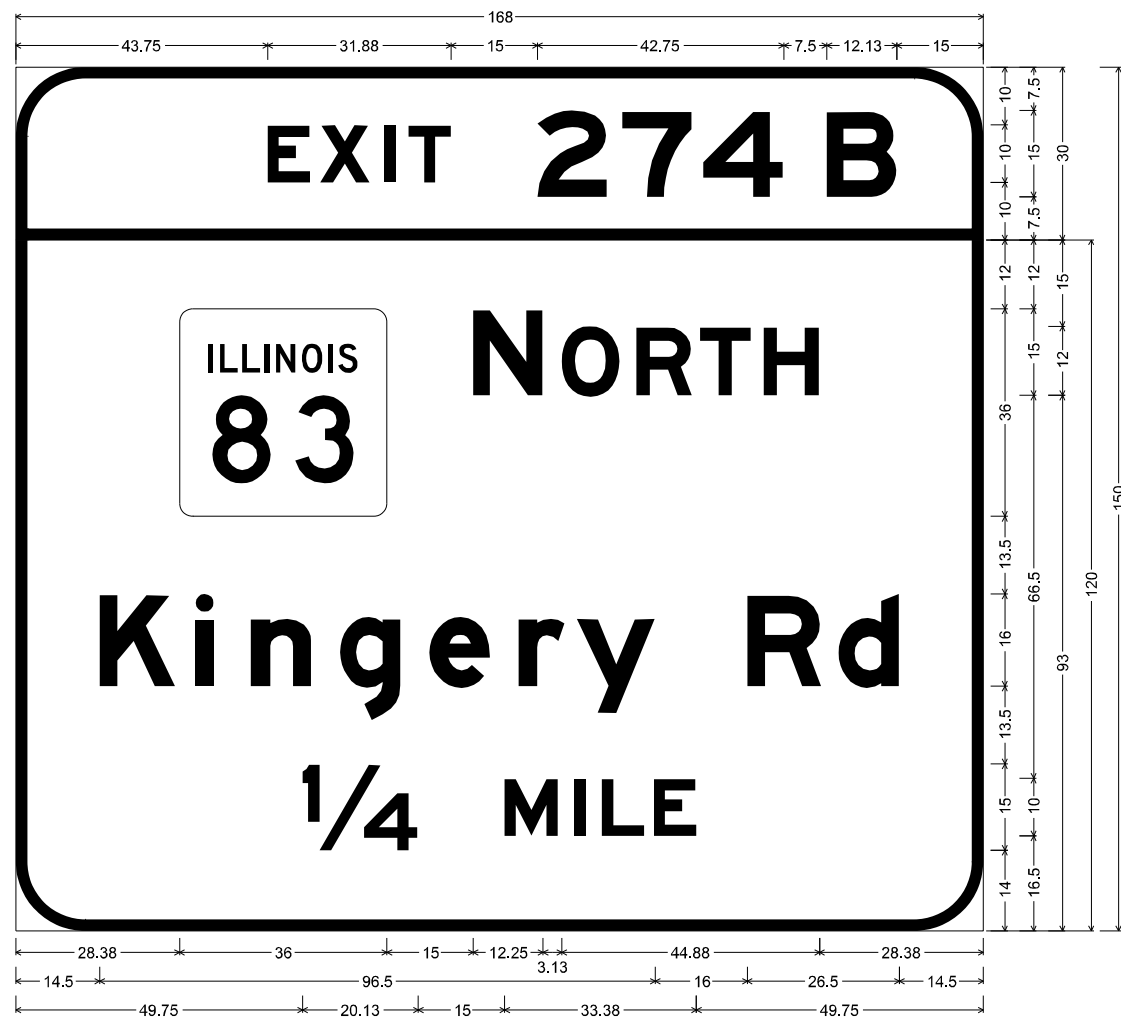

12.00" Radius, 2.00" Border, White on Green;  
 "EXIT", E Mod 2K 120% spacing; "274", E Mod 2K; "B", E Mod 2K;

12.00" Radius, 2.00" Border, White on Green;  
 "NORTH", E Mod 2K; "Kingery Rd", E Mod 2K; "1/4 MILE", E Mod 2K;

Table of widths and spaces

43.75	E	7.38	X	1.75	8.63	2.50	I	2.00	2.25	7.38	15.00	2	12.13	2.50	7	12.13	2.00	4	14.00	7.50	B	12.13	15.00				
28.38	36.00	15.00	N	12.25	3.13	O	10.13	2.88	R	9.75	1.25	T	8.88	2.25	H	9.63	28.50										
14.50	K	13.13	3.63	i	3.13	6.38	n	10.63	4.88	g	10.63	4.88	e	10.63	5.00	r	8.00	2.00	y	13.63	16.00	R	13.00	2.88	d	10.50	14.63
49.75	1/4	20.13	15.00	M	9.38	2.75	I	2.00	2.75	L	7.50	1.50	E	7.50	49.75												

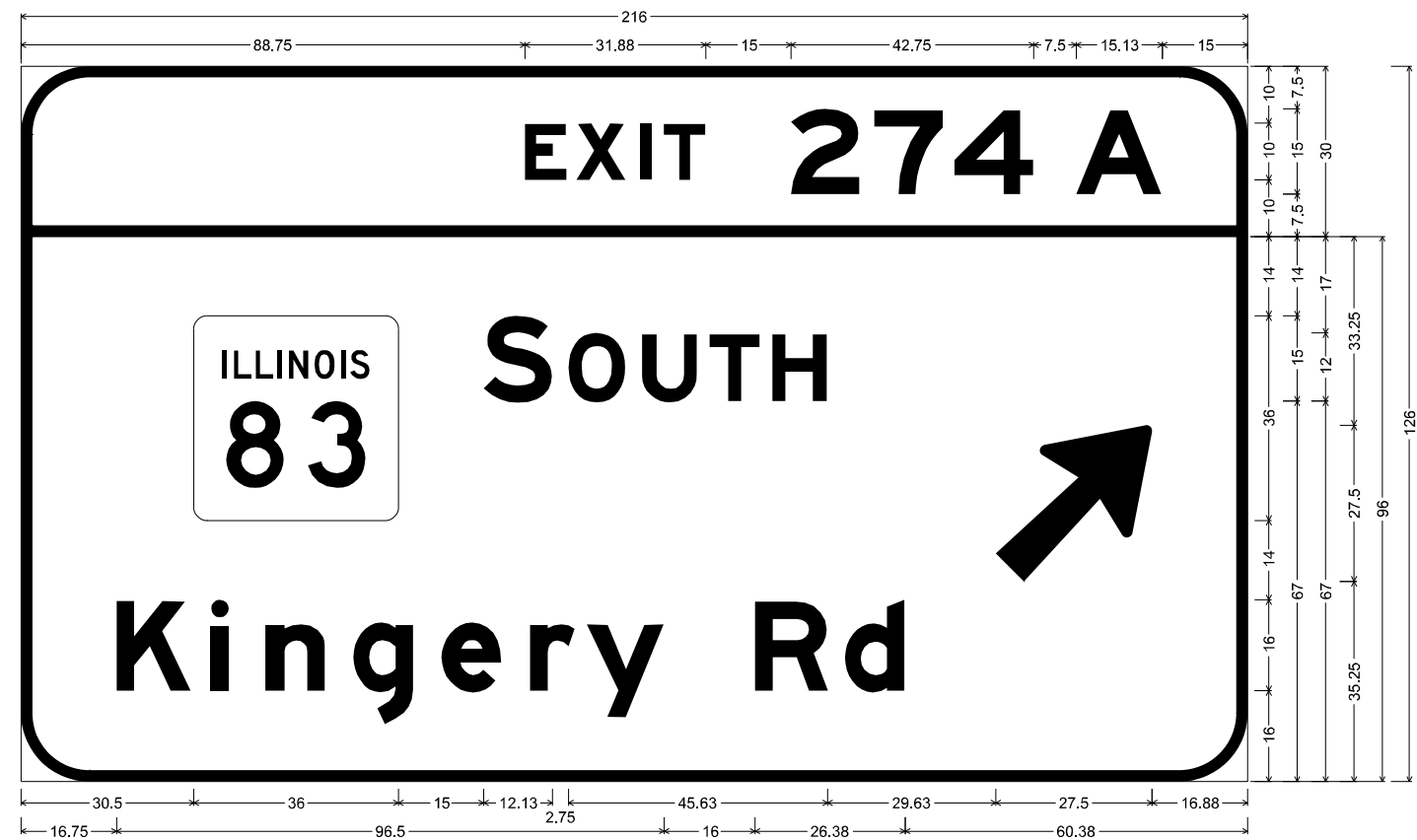

12.00" Radius, 2.00" Border, White on Green;  
 "EXIT", E Mod 2K 120% spacing; "274", E Mod 2K; "A", E Mod 2K;

12.00" Radius, 2.00" Border, White on Green;  
 "SOUTH", E Mod 2K; "Kingery Rd", E Mod 2K; Arrow 160 - 35.00" 45";

Table of widths and spaces

88.75	E	7.38	X	1.75	8.63	2.50	I	2.00	2.25	7.38	15.00	2	12.13	2.50	7	12.13	2.00	4	14.00	7.50	A	15.13	15.00				
30.50	36.00	15.00	S	12.13	2.75	O	10.13	2.88	U	9.75	2.13	T	8.88	2.13	H	9.75	29.63	27.50	16.88								
16.75	K	13.13	3.50	i	3.25	6.38	n	10.63	4.88	g	10.63	4.88	e	10.63	5.00	r	8.00	2.00	y	13.63	16.00	R	13.00	2.88	d	10.50	60.38

MODEL: D:\p\p\Design\KKS\Signs - Design\Contract-46556-Signs-Structure\Design-455-And-230-County-4-Line-84-cc-Water-Rd\00DD\62P27455\_Signs-IP-KK-CO\BIBED-06-28-21.com  
 FILE NAME: Sign\IP\Design\KKS\Signs - Design\Contract-46556-Signs-Structure\Design-455-And-230-County-4-Line-84-cc-Water-Rd\00DD\62P27455\_Signs-IP-KK-CO\BIBED-06-28-21.com

USER NAME = plascencia	DESIGNED - KK	REVISED -
DRAWN - KK / IP	REVISIONS -	
PLOT SCALE = 40,0000 * / in.	CHECKED - LP	REVISED -
PLOT DATE = 7/1/2021	DATE - 06/25/2021	REVISED -

**STATE OF ILLINOIS  
DEPARTMENT OF TRANSPORTATION**

**SIGN PANEL DESIGN**

SCALE: SHEET OF SHEETS STA. TO STA.

F.A.I. RTE.	SECTION	COUNTY	TOTAL SHEETS	SHEET NO.
55	2021-128-SG	VARIOUS	178	108
CONTRACT NO. 62P27				
ILLINOIS FED. AID PROJECT				



**DETAILS**

"LEFT" PLAQUE DETAIL DESIGN



1.88" Radius, 0.00" Border, White on Yellow;  
 "LEFT" Black, E Mod 2K 125% spacing;  
 Table of widths and spaces

L	8.88	E	2.38	8.88	F	3.13	8.88	T	1.75	8.88	8.63
---	------	---	------	------	---	------	------	---	------	------	------

STRUCTURE NUMBER		1S022I055R274. 3-000	
LOCATION		61A EXPRESSWAY	
SIZE (W x H)	EXIT PLAQUE	-	
	MAIN PANEL	13' X 10.5'	
MOUNTING / TYPE		OVERHEAD / TRUSS	
MOUNTING LOC (L, M, R)		LEFT	
SHEETING / COLOR	BACKGROUND	TYPE:	ZZ
		COLOR:	GREEN
		TYPE:	
	LEGEND / BORDER	TYPE:	ZZ
		COLOR:	WHITE
		TYPE:	

STRUCTURE NUMBER		1S022I055R274. 3-000	
LOCATION		61B EXPRESSWAY	
SIZE (W x H)	EXIT PLAQUE	-	
	MAIN PANEL	19' X 8.5'	
MOUNTING / TYPE		OVERHEAD / TRUSS	
MOUNTING LOC (L, M, R)		MIDDLE	
SHEETING / COLOR	BACKGROUND	TYPE:	ZZ
		COLOR:	GREEN
		TYPE:	
	LEGEND / BORDER	TYPE:	ZZ
		COLOR:	WHITE
		TYPE:	

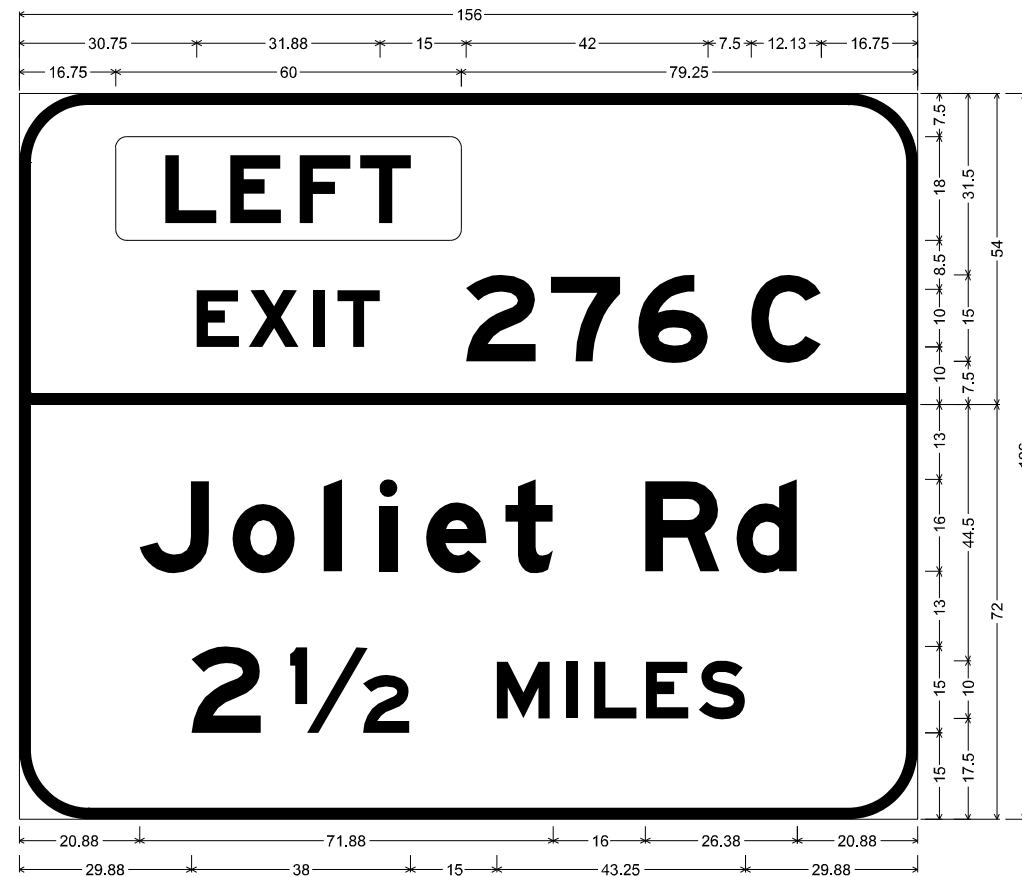

12.00" Radius, 2.00" Border, White on Green;  
 Rounded Rectangle 1.88" Radius Yellow;  
 "EXIT", E Mod 2K 120% spacing; "276", E Mod 2K; "C", E Mod 2K;  
 12.00" Radius, 2.00" Border, White on Green;  
 "Joliet Rd", E Mod 2K; "2 1/2", E Mod 2K; "MILES", E Mod 2K;  
 Table of widths and spaces

16.75	60.00	79.25														
30.75	E 7.50	1.63	X 8.75	2.50	I 2.00	2.13	T 7.38	15.00	Z 12.13	2.50	7 12.25	3.00	6 12.13	7.50	C 12.13	16.75
20.88	J 12.13	4.00	O 10.88	5.00	I 3.25	6.38	I 3.13	5.00	E 10.50	3.25	8.38	16.00	R 12.88	2.88	D 10.63	20.88
29.88	Z 12.13	5.00	1/2 20.88	15.00	M 9.38	2.75	I 2.00	2.75	L 7.50	1.50	E 7.50	1.75	S 8.13	29.88		



12.00" Radius, 2.00" Border, White on Green;  
 "EXITS", E Mod 2K 120% spacing; "276", E Mod 2K; "A", E Mod 2K; "B", E Mod 2K;  
 12.00" Radius, 2.00" Border, White on Green;  
 "County Line Rd", E Mod 2K; "2 MILES", E Mod 2K;  
 Table of widths and spaces

59.38	E 7.50	1.63	X 8.75	2.50	I 2.00	2.13	T 7.38	1.75	S 8.13	15.00	Z 12.13	2.63	7 12.13	3.00	6 12.13	7.50	A 15.13	5.00	7.50	B 12.25	15.00			
14.63	C 13.00	3.00	O 10.88	5.00	U 10.50	6.38	N 10.63	4.63	T 8.25	3.38	Y 13.63	16.00	L 11.88	3.50	I 3.25	6.38	N 10.50	5.00	E 10.50	16.00	R 13.00	2.88	D 10.50	14.75
78.88	Z 12.13	15.00	M 9.25	2.88	I 1.88	2.88	L 7.38	1.63	E 7.38	1.75	S 8.13	78.88												

MODEL: D:\p\p\Design\KKS\Signs - Design\Structure-Design-485546-Signs-Structure-Design-485546-and-290-County-Line-Rd-61A-61B-61C-61D-61E-61F-61G-61H-61I-61J-61K-61L-61M-61N-61O-61P-61Q-61R-61S-61T-61U-61V-61W-61X-61Y-61Z-61AA-61AB-61AC-61AD-61AE-61AF-61AG-61AH-61AI-61AJ-61AK-61AL-61AM-61AN-61AO-61AP-61AQ-61AR-61AS-61AT-61AU-61AV-61AW-61AX-61AY-61AZ-61BA-61BB-61BC-61BD-61BE-61BF-61BG-61BH-61BI-61BJ-61BK-61BL-61BM-61BN-61BO-61BP-61BQ-61BR-61BS-61BT-61BU-61BV-61BW-61BX-61BY-61BZ-61CA-61CB-61CC-61CD-61CE-61CF-61CG-61CH-61CI-61CJ-61CK-61CL-61CM-61CN-61CO-61CP-61CQ-61CR-61CS-61CT-61CU-61CV-61CW-61CX-61CY-61CZ-61DA-61DB-61DC-61DD-61DE-61DF-61DG-61DH-61DI-61DJ-61DK-61DL-61DM-61DN-61DO-61DP-61DQ-61DR-61DS-61DT-61DU-61DV-61DW-61DX-61DY-61DZ-61EA-61EB-61EC-61ED-61EE-61EF-61EG-61EH-61EI-61EJ-61EK-61EL-61EM-61EN-61EO-61EP-61EQ-61ER-61ES-61ET-61EU-61EV-61EW-61EX-61EY-61EZ-61FA-61FB-61FC-61FD-61FE-61FF-61FG-61FH-61FI-61FJ-61FK-61FL-61FM-61FN-61FO-61FP-61FQ-61FR-61FS-61FT-61FU-61FV-61FW-61FX-61FY-61FZ-61GA-61GB-61GC-61GD-61GE-61GF-61GG-61GH-61GI-61GJ-61GK-61GL-61GM-61GN-61GO-61GP-61GQ-61GR-61GS-61GT-61GU-61GV-61GW-61GX-61GY-61GZ-61HA-61HB-61HC-61HD-61HE-61HF-61HG-61HH-61HI-61HJ-61HK-61HL-61HM-61HN-61HO-61HP-61HQ-61HR-61HS-61HT-61HU-61HV-61HW-61HX-61HY-61HZ-61IA-61IB-61IC-61ID-61IE-61IF-61IG-61IH-61II-61IJ-61IK-61IL-61IM-61IN-61IO-61IP-61IQ-61IR-61IS-61IT-61IU-61IV-61IW-61IX-61IY-61IZ-61JA-61JB-61JC-61JD-61JE-61JF-61JG-61JH-61JI-61JJ-61JK-61JL-61JM-61JN-61JO-61JP-61JQ-61JR-61JS-61JT-61JU-61JV-61JW-61JX-61JY-61JZ-61KA-61KB-61KC-61KD-61KE-61KF-61KG-61KH-61KI-61KJ-61KK-61KL-61KM-61KN-61KO-61KP-61KQ-61KR-61KS-61KT-61KU-61KV-61KW-61KX-61KY-61KZ-61LA-61LB-61LC-61LD-61LE-61LF-61LG-61LH-61LI-61LJ-61LK-61LL-61LM-61LN-61LO-61LP-61LQ-61LR-61LS-61LT-61LU-61LV-61LW-61LX-61LY-61LZ-61MA-61MB-61MC-61MD-61ME-61MF-61MG-61MH-61MI-61MJ-61MK-61ML-61MN-61MO-61MP-61MQ-61MR-61MS-61MT-61MU-61MV-61MW-61MX-61MY-61MZ-61NA-61NB-61NC-61ND-61NE-61NF-61NG-61NH-61NI-61NJ-61NK-61NL-61NM-61NO-61NP-61NQ-61NR-61NS-61NT-61NU-61NV-61NW-61NX-61NY-61NZ-61OA-61OB-61OC-61OD-61OE-61OF-61OG-61OH-61OI-61OJ-61OK-61OL-61OM-61ON-61OO-61OP-61OQ-61OR-61OS-61OT-61OU-61OV-61OW-61OX-61OY-61OZ-61PA-61PB-61PC-61PD-61PE-61PF-61PG-61PH-61PI-61PJ-61PK-61PL-61PM-61PN-61PO-61PP-61PQ-61PR-61PS-61PT-61PU-61PV-61PW-61PX-61PY-61PZ-61QA-61QB-61QC-61QD-61QE-61QF-61QG-61QH-61QI-61QJ-61QK-61QL-61QM-61QN-61QO-61QP-61QQ-61QR-61QS-61QT-61QU-61QV-61QW-61QX-61QY-61QZ-61RA-61RB-61RC-61RD-61RE-61RF-61RG-61RH-61RI-61RJ-61RK-61RL-61RM-61RN-61RO-61RP-61RQ-61RR-61RS-61RT-61RU-61RV-61RW-61RX-61RY-61RZ-61SA-61SB-61SC-61SD-61SE-61SF-61SG-61SH-61SI-61SJ-61SK-61SL-61SM-61SN-61SO-61SP-61SQ-61SR-61SS-61ST-61SU-61SV-61SW-61SX-61SY-61SZ-61TA-61TB-61TC-61TD-61TE-61TF-61TG-61TH-61TI-61TJ-61TK-61TL-61TM-61TN-61TO-61TP-61TQ-61TR-61TS-61TT-61TU-61TV-61TW-61TX-61TY-61TZ-61UA-61UB-61UC-61UD-61UE-61UF-61UG-61UH-61UI-61UJ-61UK-61UL-61UM-61UN-61UO-61UP-61UQ-61UR-61US-61UT-61UU-61UV-61UW-61UX-61UY-61UZ-61VA-61VB-61VC-61VD-61VE-61VF-61VG-61VH-61VI-61VJ-61VK-61VL-61VM-61VN-61VO-61VP-61VQ-61VR-61VS-61VT-61VU-61VV-61VW-61VX-61VY-61VZ-61WA-61WB-61WC-61WD-61WE-61WF-61WG-61WH-61WI-61WJ-61WK-61WL-61WM-61WN-61WO-61WP-61WQ-61WR-61WS-61WT-61WU-61WV-61WW-61WX-61WY-61WZ-61XA-61XB-61XC-61XD-61XE-61XF-61XG-61XH-61XI-61XJ-61XK-61XL-61XM-61XN-61XO-61XP-61XQ-61XR-61XS-61XT-61XU-61XV-61XW-61XX-61XY-61XZ-61YA-61YB-61YC-61YD-61YE-61YF-61YG-61YH-61YI-61YJ-61YK-61YL-61YM-61YN-61YO-61YP-61YQ-61YR-61YS-61YT-61YU-61YV-61YW-61YX-61YY-61YZ-61ZA-61ZB-61ZC-61ZD-61ZE-61ZF-61ZG-61ZH-61ZI-61ZJ-61ZK-61ZL-61ZM-61ZN-61ZO-61ZP-61ZQ-61ZR-61ZS-61ZT-61ZU-61ZV-61ZW-61ZX-61ZY-61ZZ

USER NAME = plascencia	DESIGNED - KK	REVISED -
DRAWN - KK / IP	REVISED -	
PLOT SCALE = 40,0000' / in.	CHECKED - LP	REVISED -
PLOT DATE = 7/1/2021	DATE - 06/25/2021	REVISED -

**STATE OF ILLINOIS  
 DEPARTMENT OF TRANSPORTATION**

**SIGN PANEL DESIGN**

SCALE: SHEET OF SHEETS STA. TO STA.

F.A.I. RTE.	SECTION	COUNTY	TOTAL SHEETS	SHEET NO.
55	2021-128-SG	VARIOUS	178	109
CONTRACT NO. 62P27				
ILLINOIS FED. AID PROJECT				

STRUCTURE NUMBER		1S022I055R274.3-000	
LOCATION		61C EXPRESSWAY	
SIZE (W x H)	EXIT PLAQUE	-	
	MAIN PANEL	18' X 10.5'	
MOUNTING / TYPE		OVERHEAD / TRUSS	
MOUNTING LOC (L, M, R)		RIGHT	
SHEETING / COLOR	BACKGROUND	TYPE:	ZZ
		COLOR:	GREEN
		TYPE:	
	LEGEND / BORDER	COLOR:	
		TYPE:	ZZ
		COLOR:	WHITE

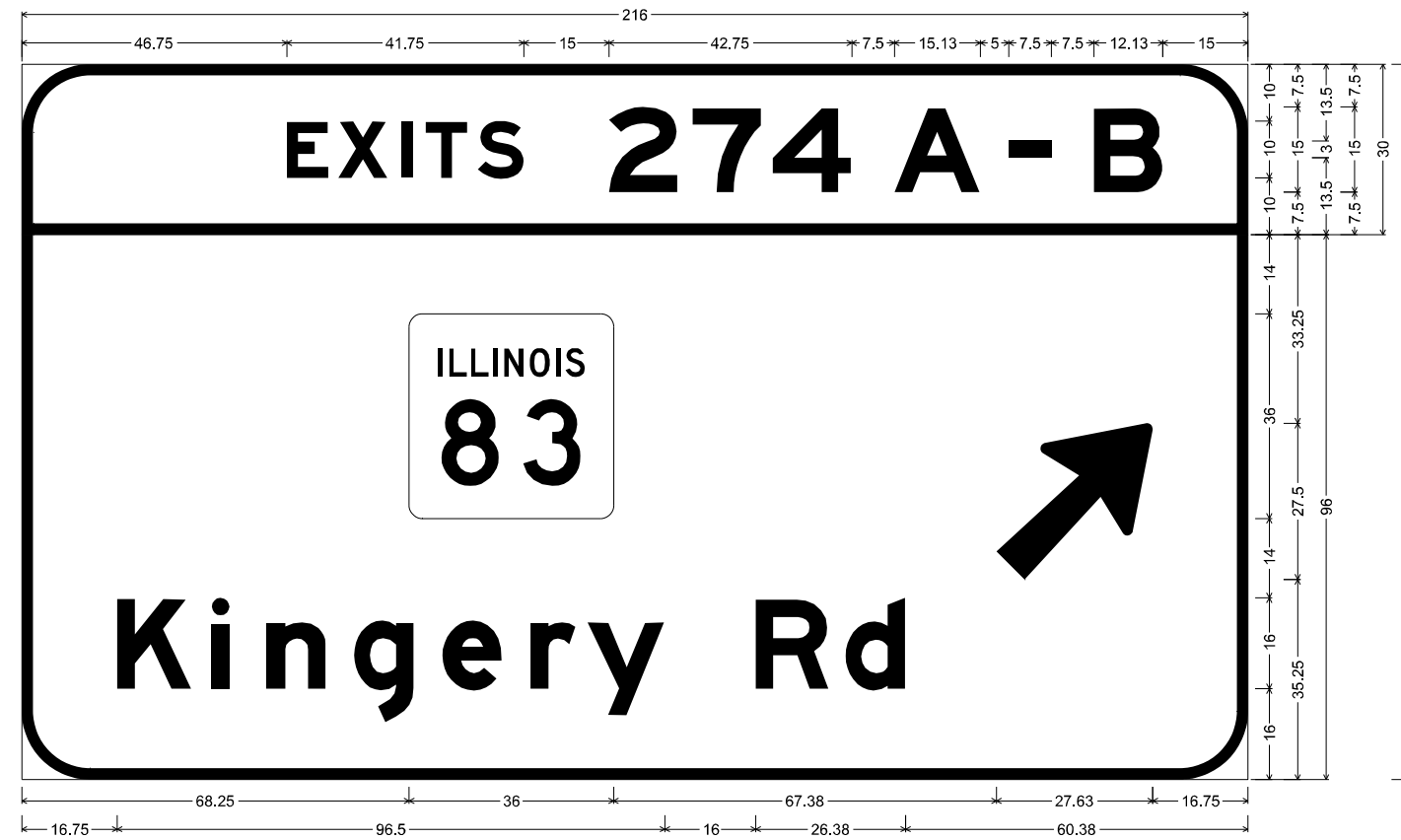

12.00" Radius, 2.00" Border, White on Green;  
 "EXITS", E Mod 2K 120% spacing; "274", E Mod 2K; "A", E Mod 2K; "B", E Mod 2K;

12.00" Radius, 2.00" Border, White on Green;  
 "Kingery Rd", E Mod 2K; Arrow 160 - 35.00" 45°;

Table of widths and spaces

46.75	E	7.38	1.63	X	8.75	2.50	I	2.00	2.13	T	7.38	1.88	S	8.00	15.00	2	12.25	2.50	7	12.13	2.00	4	13.88	7.50	A	15.25	5.00	□	7.50	7.50	B	12.13	15.00	
68.25	83	36.00	67.38	27.63	16.75																													
16.75	K	13.13	3.50	i	3.25	6.38	n	10.63	4.88	g	10.63	4.88	e	10.63	5.00	r	8.00	2.00	y	13.63	16.00	R	13.00	2.88	d	10.50	60.38							

MODEL: D:\p\h  
 FILE NAME: S:\IP\Design\KKS\Signs Design\Contract-46556-Signs-Structure-Design-155-and-1200-County-4-Line-84-co-Water-Rd\CADD\62P27455\_Signs-IP-KK-COMBINED-06-28-21.dwg

USER NAME = plascencjal	DESIGNED - KK	REVISED -
DRAWN - KK / IP	REVISOR -	
PLOT SCALE = 40,0000 * / in.	CHECKED - LP	REVISED -
PLOT DATE = 7/1/2021	DATE - 06/25/2021	REVISED -

**STATE OF ILLINOIS**  
**DEPARTMENT OF TRANSPORTATION**

<b>SIGN PANEL DESIGN</b>			
SCALE:	SHEET	OF	SHEETS
	STA.		TO STA.

F.A.I. RTE.	SECTION	COUNTY	TOTAL SHEETS	SHEET NO.
55	2021-128-SG	VARIOUS	178	110
CONTRACT NO. 62P27				
ILLINOIS FED. AID PROJECT				

STRUCTURE NUMBER		1S0221055R272. 7-000	
LOCATION		63A	EXPRESSWAY
SIZE (W x H)	EXIT PLAQUE	-	
	MAIN PANEL	15.5' X 12.5'	
MOUNTING / TYPE		OVERHEAD / TRUSS	
MOUNTING LOC (L, M, R)		LEFT	
SHEETING / COLOR	BACKGROUND	TYPE:	ZZ
		COLOR:	GREEN
		TYPE:	
	LEGEND / BORDER	TYPE:	ZZ
		COLOR:	WHITE
		TYPE:	
	COLOR:		

STRUCTURE NUMBER		1S0221055R272. 7-000	
LOCATION		63B	EXPRESSWAY
SIZE (W x H)	EXIT PLAQUE	-	
	MAIN PANEL	13' X 11'	
MOUNTING / TYPE		OVERHEAD / TRUSS	
MOUNTING LOC (L, M, R)		MIDDLE	
SHEETING / COLOR	BACKGROUND	TYPE:	ZZ
		COLOR:	GREEN
		TYPE:	
	LEGEND / BORDER	TYPE:	ZZ
		COLOR:	WHITE
		TYPE:	
	COLOR:		

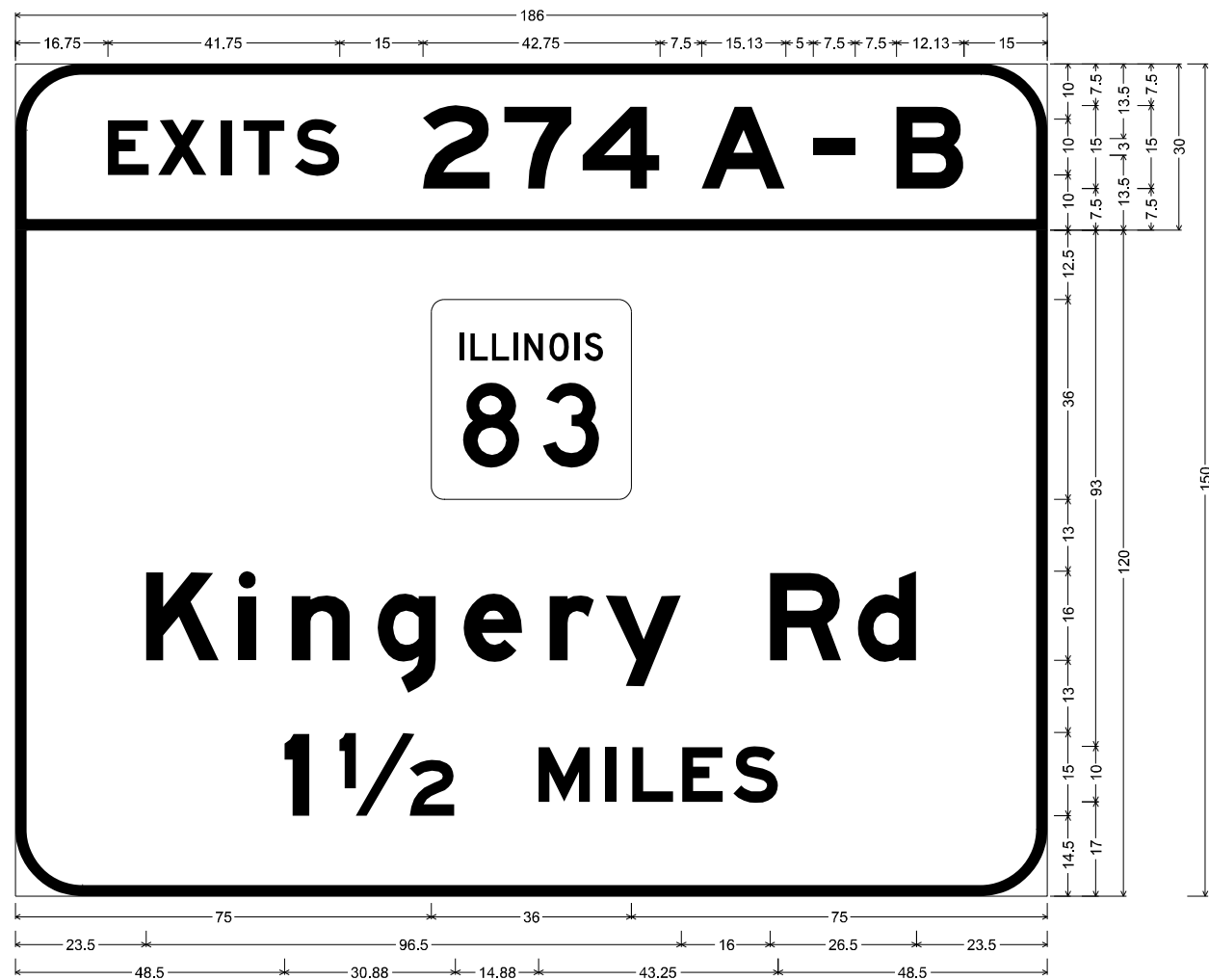

12.00" Radius, 2.00" Border, White on Green;  
 "EXITS", E Mod 2K 120% spacing; "274", E Mod 2K; "A", E Mod 2K; "B", E Mod 2K;

12.00" Radius, 2.00" Border, White on Green;  
 "Kingery Rd", E Mod 2K; "1 1/2 MILES", E Mod 2K;  
 Table of widths and spaces

16.75	E	7.38	X	1.63	8.75	I	2.50	2.00	2.13	T	7.38	S	1.88	8.00	15.00	12.25	2.50	12.13	2.00	13.88	7.50	A	15.25	5.00	7.50	7.50	12.13	15.00	
75.00		36.00		75.00																									
23.50	K	13.13	i	3.63	3.13	n	10.63	4.88	g	10.63	4.88	e	10.63	5.00	r	8.00	2.00	y	13.63	16.00	R	13.00	2.88	d	10.50	23.63			
48.50	I	4.50	5.38	1/2	20.88	M	15.00	9.38	2.75	I	2.00	2.88	L	7.38	1.50	E	7.50	1.75	S	8.13	48.50								

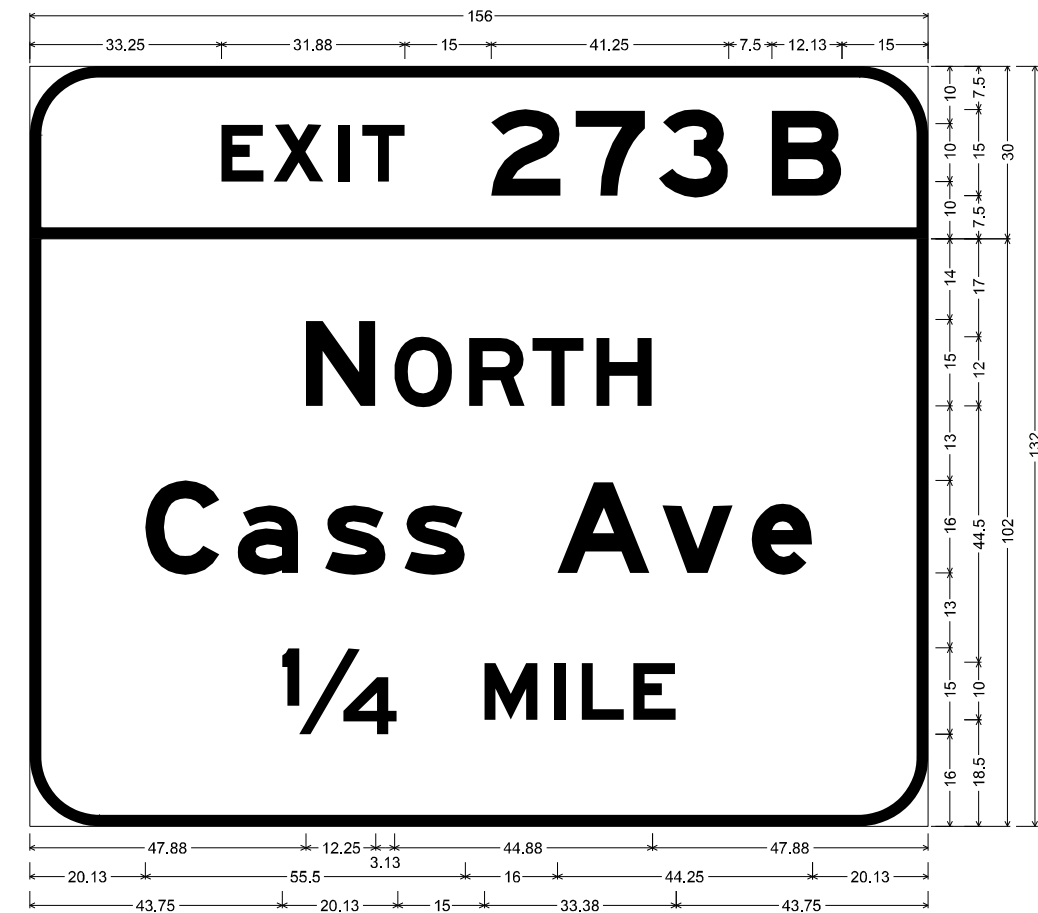

12.00" Radius, 2.00" Border, White on Green;  
 "EXIT", E Mod 2K 120% spacing; "273", E Mod 2K; "B", E Mod 2K;

12.00" Radius, 2.00" Border, White on Green;  
 "NORTH", E Mod 2K; "Cass Ave", E Mod 2K; "1/4 MILE", E Mod 2K;  
 Table of widths and spaces

33.25	E	7.38	X	1.75	8.63	I	2.50	2.00	2.25	T	7.38	15.00	12.13	2.50	12.13	2.25	12.25	7.50	12.13	15.00								
47.88	N	12.25	O	3.13	10.13	R	2.88	9.75	1.25	T	8.88	2.25	H	9.63	48.00													
20.13	C	12.88	a	3.13	10.50	s	10.63	3.13	s	10.63	16.00	A	16.13	2.00	v	12.38	3.25	e	10.50	20.13								
43.75	1/4	20.13	M	15.00	9.38	2.75	I	2.00	2.75	L	7.50	1.50	E	7.50	43.75													

MODEL: D:\p\p\Design\KKS\Signs - Design\Contract-48546-Signs-Structure-Design-155-And-1200-County-4-Line-84-co-Water-Rd\ICDD\62P27455\_Signs\Color-KK-CO\BIBED-06-28-21.com  
 FILE NAME: S:\P\Design\KKS\Signs - Design\Contract-48546-Signs-Structure-Design-155-And-1200-County-4-Line-84-co-Water-Rd\ICDD\62P27455\_Signs\Color-KK-CO\BIBED-06-28-21.com

USER NAME =	plascencia	DESIGNED -	KK	REVISED -	
DRAWN -	KK / IP	REVISED -		REVISED -	
PLOT SCALE =	40,0000 * / in.	CHECKED -	LP	REVISED -	
PLOT DATE =	7/1/2021	DATE -	06/25/2021	REVISED -	

**STATE OF ILLINOIS  
DEPARTMENT OF TRANSPORTATION**

**SIGN PANEL DESIGN**

SCALE: SHEET OF SHEETS STA. TO STA.

F.A.I. RTE.	SECTION	COUNTY	TOTAL SHEETS	SHEET NO.
55	2021-128-SG	VARIOUS	178	111
CONTRACT NO. 62P27				
ILLINOIS FED. AID PROJECT				

STRUCTURE NUMBER		1S022I055R272.7-000	
LOCATION		63C	EXPRESSWAY
SIZE (W x H)	EXIT PLAQUE	-	
	MAIN PANEL	15.5' X 8.5'	
MOUNTING / TYPE		OVERHEAD / TRUSS	
MOUNTING LOC (L, M, R)		RIGHT	
SHEETING / COLOR	BACKGROUND	TYPE:	ZZ
		COLOR:	GREEN
		TYPE:	
		COLOR:	
	LEGEND / BORDER	TYPE:	ZZ
		COLOR:	WHITE
		TYPE:	
		COLOR:	

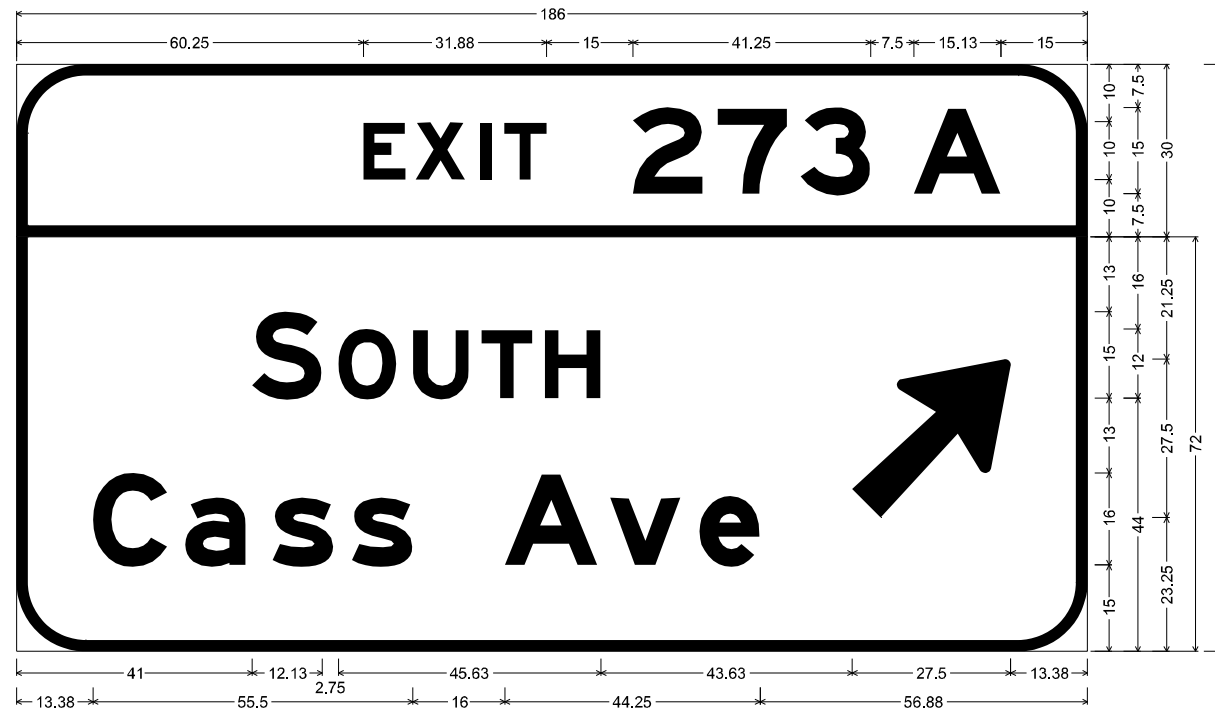

12.00" Radius, 2.00" Border, White on Green;  
 "EXIT", E Mod 2K 120% spacing; "273", E Mod 2K; "A", E Mod 2K;

12.00" Radius, 2.00" Border, White on Green;  
 "SOUTH", E Mod 2K; "Cass Ave", E Mod 2K; Arrow 160 - 35.00" 45";

Table of widths and spaces

60.25	E	7.38	1.75	X	8.63	2.50	I	2.00	2.25	T	7.38	15.00	2	12.13	2.50	7	12.13	2.25	3	12.25	7.50	A	15.13	15.00
41.00	S	12.13	2.75	O	10.13	2.88	U	9.75	2.13	T	8.88	2.13	H	9.75	43.63	27.50	13.38							
13.38	C	12.88	3.00	a	10.63	4.63	s	10.50	3.25	s	10.63	16.00	A	16.13	2.00	v	12.38	3.25	e	10.50	56.88			

MODEL: D:\p\p\Design\KKS\Signs Design\Contract-46556-5\Signs-Structure-Design-155.mxd  
 FILE NAME: S:\IP\Design\KKS\Signs Design\Contract-46556-5\Signs-Structure-Design-155.mxd  
 USER: plascencjal  
 DATE: 7/1/2021

USER NAME = plascencjal	DESIGNED - KK	REVISED -
DRAWN - KK / IP	REVISIONS	
PLOT SCALE = 40,0000 * / in.	CHECKED - LP	REVISED -
PLOT DATE = 7/1/2021	DATE - 06/25/2021	REVISED -

**STATE OF ILLINOIS  
DEPARTMENT OF TRANSPORTATION**

<b>SIGN PANEL DESIGN</b>			
SCALE:	SHEET	OF	SHEETS
	STA.		TO STA.

F.A.I. RTE.	SECTION	COUNTY	TOTAL SHEETS	SHEET NO.
55	2021-128-5G	VARIOUS	178	112
			CONTRACT NO. 62P27	
		ILLINOIS	FED. AID PROJECT	

STRUCTURE NUMBER		1S0221055R270. 7-000	
LOCATION		65A	EXPRESSWAY
SIZE (W x H)	EXIT PLAQUE	-	
	MAIN PANEL	13.5' X 9.5'	
MOUNTING / TYPE		OVERHEAD / TRUSS	
MOUNTING LOC (L, M, R)		LEFT	
SHEETING / COLOR	BACKGROUND	TYPE:	ZZ
		COLOR:	WHITE
		TYPE:	
	LEGEND / BORDER	TYPE:	ZZ
		COLOR:	BLACK
		TYPE:	

STRUCTURE NUMBER		1S0221055R270. 7-000	
LOCATION		65B	EXPRESSWAY
SIZE (W x H)	EXIT PLAQUE	-	
	MAIN PANEL	15.5' X 8.5'	
MOUNTING / TYPE		OVERHEAD / TRUSS	
MOUNTING LOC (L, M, R)		MIDDLE LEFT	
SHEETING / COLOR	BACKGROUND	TYPE:	ZZ
		COLOR:	GREEN
		TYPE:	
	LEGEND / BORDER	TYPE:	ZZ
		COLOR:	WHITE
		TYPE:	

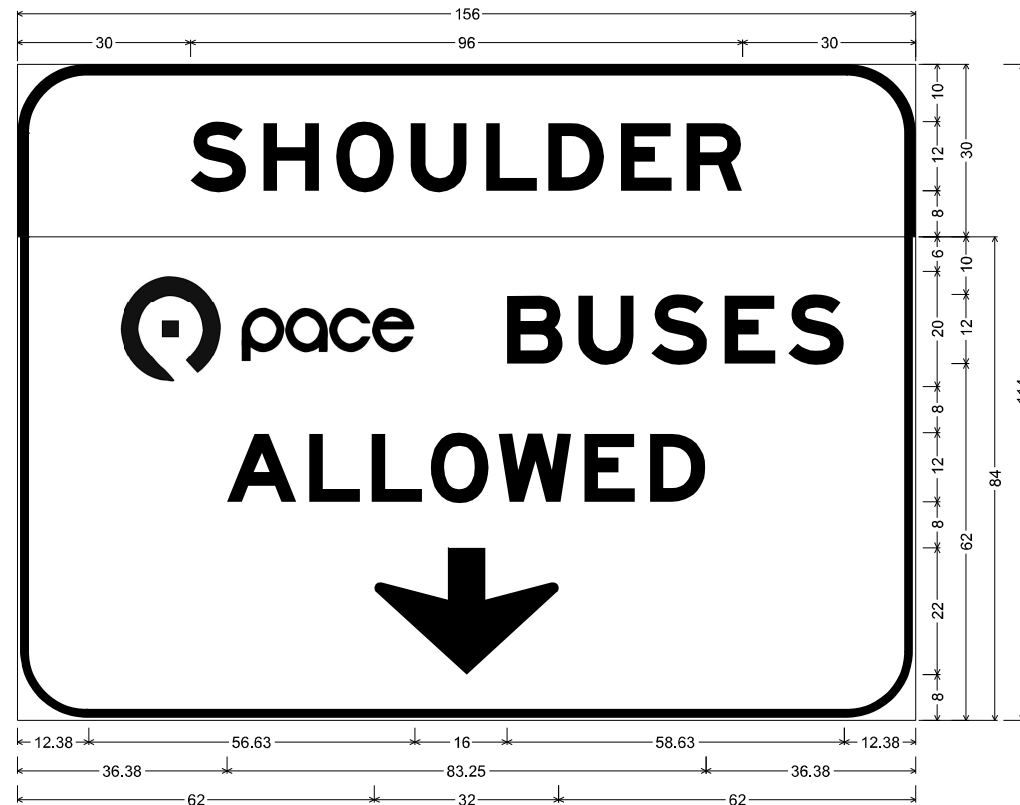

12.00" Radius, 2.00" Border, White on Black;  
 "SHOULDER", E Mod 2K;  
 12.00" Radius, 1.50" Border, 0.50" Indent, Black on White;  
 Rectangle White; "BUSES", E Mod 2K; "ALLOWED", E Mod 2K; Down Arrow 22.00" 270";  
 Table of widths and spaces

30.00	S	9.75	3.00	H	9.75	2.88	O	10.13	2.88	U	9.63	3.38	L	8.88	2.00	D	9.63	2.88	E	8.88	2.50	R	9.75	30.13
12.38		56.63	16.00	B	9.75	2.63	U	9.75	3.00	S	9.75	3.00	E	8.88	2.13	S	9.75	12.38						
36.38	A	12.13	2.25	L	8.88	1.88	L	8.88	1.38	O	10.13	1.63	W	12.75	2.13	E	8.88	2.50	D	9.75	36.50			
62.00		32.00	62.00																					

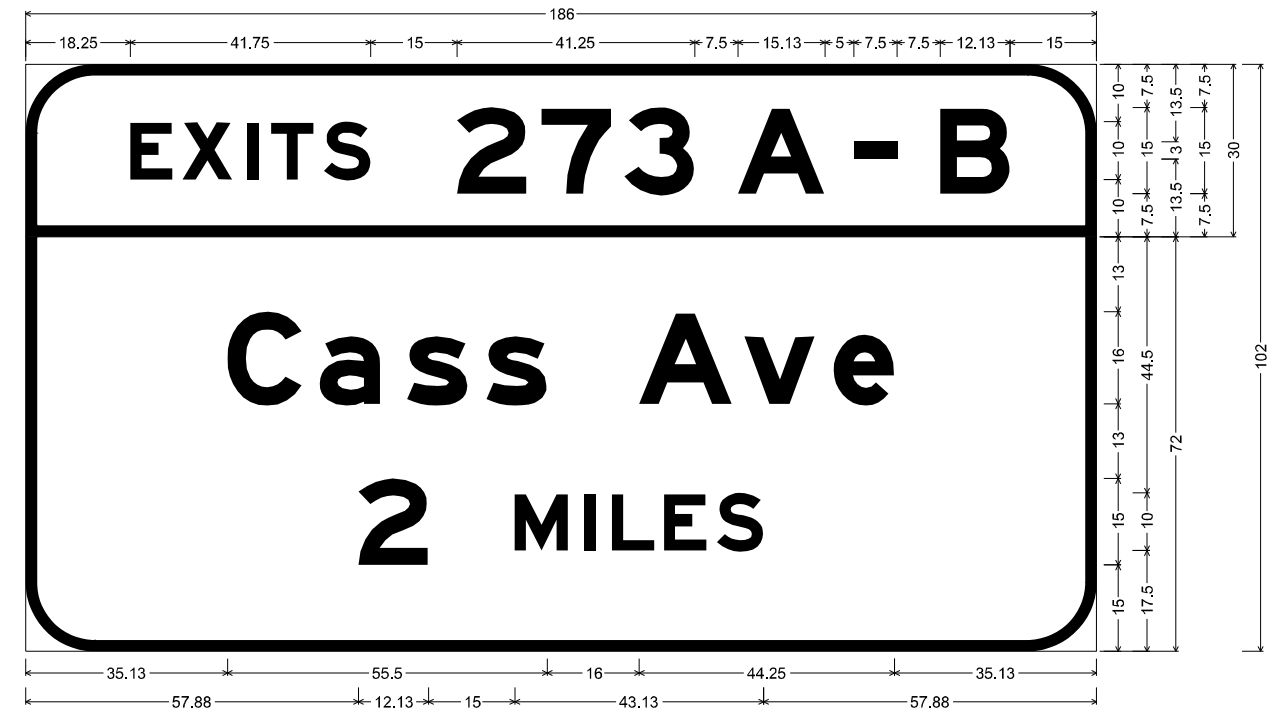

12.00" Radius, 2.00" Border, White on Green;  
 "EXITS", E Mod 2K 120% spacing; "273", E Mod 2K; "A", E Mod 2K; "B", E Mod 2K;  
 12.00" Radius, 2.00" Border, White on Green;  
 "Cass Ave", E Mod 2K; "2 MILES", E Mod 2K;  
 Table of widths and spaces

18.25	E	7.38	1.63	X	8.75	2.50	I	2.00	2.13	T	7.38	1.88	S	8.00	15.00	Z	12.25	2.50	7	12.13	2.25	3	12.13	7.50	A	15.25	5.00		7.50	7.50	B	12.13	15.00	
35.13	C	12.88	3.13	a	10.50	4.63	s	10.63	3.13	s	10.63	16.00	A	16.13	2.00	v	12.38	3.25	e	10.50	35.13													
57.88	Z	12.13	15.00	M	9.25	2.88	I	1.88	2.88	L	7.38	1.63	E	7.38	1.75	S	8.13	57.88																

MODEL: D:\p\p\Design\KKS\Signs Design\Contract-48556-Signs-Structure-Design-155-and-1200-County-4-Enc-84-cc-Viewer-801\CD\62P27-155\_Signs\KKS-IP-KK-CO\BIBED-06-28-21.com  
 FILE NAME: Sign\IP\Design\KKS\Signs Design\Contract-48556-Signs-Structure-Design-155-and-1200-County-4-Enc-84-cc-Viewer-801\CD\62P27-155\_Signs\KKS-IP-KK-CO\BIBED-06-28-21.com

USER NAME = plascencia	DESIGNED - KK	REVISED -
DRAWN - KK / IP	CHECKED - LP	REVISED -
PLOT SCALE = 40,0000 * / in.	DATE - 06/25/2021	REVISED -
PLOT DATE = 7/1/2021		

STATE OF ILLINOIS  
 DEPARTMENT OF TRANSPORTATION

SIGN PANEL DESIGN

SCALE: SHEET OF SHEETS STA. TO STA.

F.A.I. RTE.	SECTION	COUNTY	TOTAL SHEETS	SHEET NO.
55	2021-128-SG	VARIOUS	178	113
CONTRACT NO. 62P27				
ILLINOIS FED. AID PROJECT				

STRUCTURE NUMBER		1S0221055R270. 7-000	
LOCATION		65C	EXPRESSWAY
SIZE (W x H)	EXIT PLAQUE	-	
	MAIN PANEL	13.5' X 11'	
MOUNTING / TYPE		OVERHEAD / TRUSS	
MOUNTING LOC (L, M, R)		MIDDLE RIGHT	
SHEETING / COLOR	BACKGROUND	TYPE:	ZZ
		COLOR:	GREEN
		TYPE:	
	LEGEND / BORDER	TYPE:	ZZ
		COLOR:	WHITE
		TYPE:	

STRUCTURE NUMBER		1S0221055R270. 7-000	
LOCATION		65D	EXPRESSWAY
SIZE (W x H)	EXIT PLAQUE	-	
	MAIN PANEL	14.5' X 11.5'	
MOUNTING / TYPE		OVERHEAD / TRUSS	
MOUNTING LOC (L, M, R)		RIGHT	
SHEETING / COLOR	BACKGROUND	TYPE:	ZZ
		COLOR:	GREEN
		TYPE:	
	LEGEND / BORDER	TYPE:	ZZ
		COLOR:	WHITE
		TYPE:	

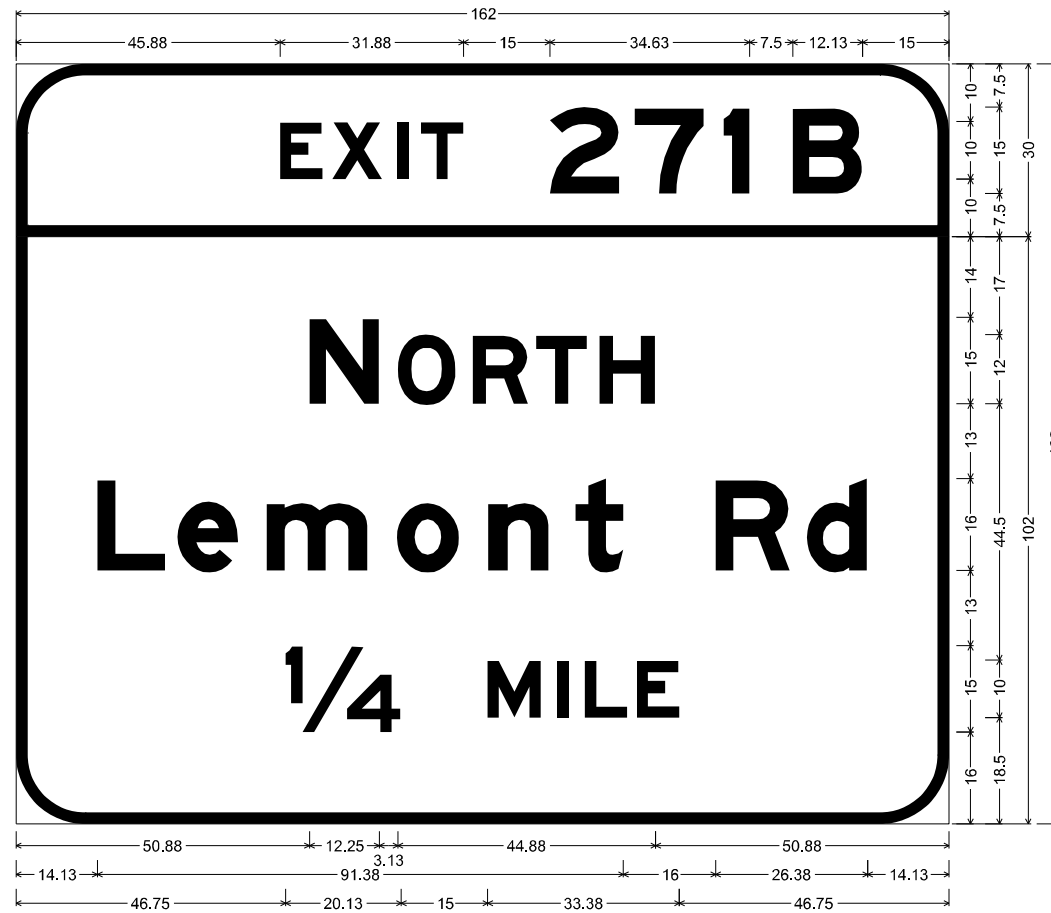

12.00" Radius, 2.00" Border, White on Green;  
 "EXIT", E Mod 2K 120% spacing; "271", E Mod 2K; "B", E Mod 2K;

12.00" Radius, 2.00" Border, White on Green;  
 "NORTH", E Mod 2K; "Lemont Rd", E Mod 2K; "1/4 MILE", E Mod 2K;

Table of widths and spaces

45.88	E	7.38	1.63	X	8.75	2.50	I	2.00	2.13	T	7.38	15.00	Z	12.25	2.50	7	12.13	3.38	I	4.50	7.50	B	12.13	15.00
50.88	N	12.25	3.13	O	10.13	2.88	R	9.75	1.25	T	8.88	2.25	H	9.63	51.00									
14.13	L	11.88	2.00	e	10.63	4.88	m	17.63	5.00	o	10.88	4.88	n	10.63	4.63	t	8.25	16.00	R	13.00	2.88	d	10.63	14.13
46.75	1/4	20.13	15.00	M	9.38	2.75	I	2.00	2.75	L	7.50	1.50	E	7.50	46.75									

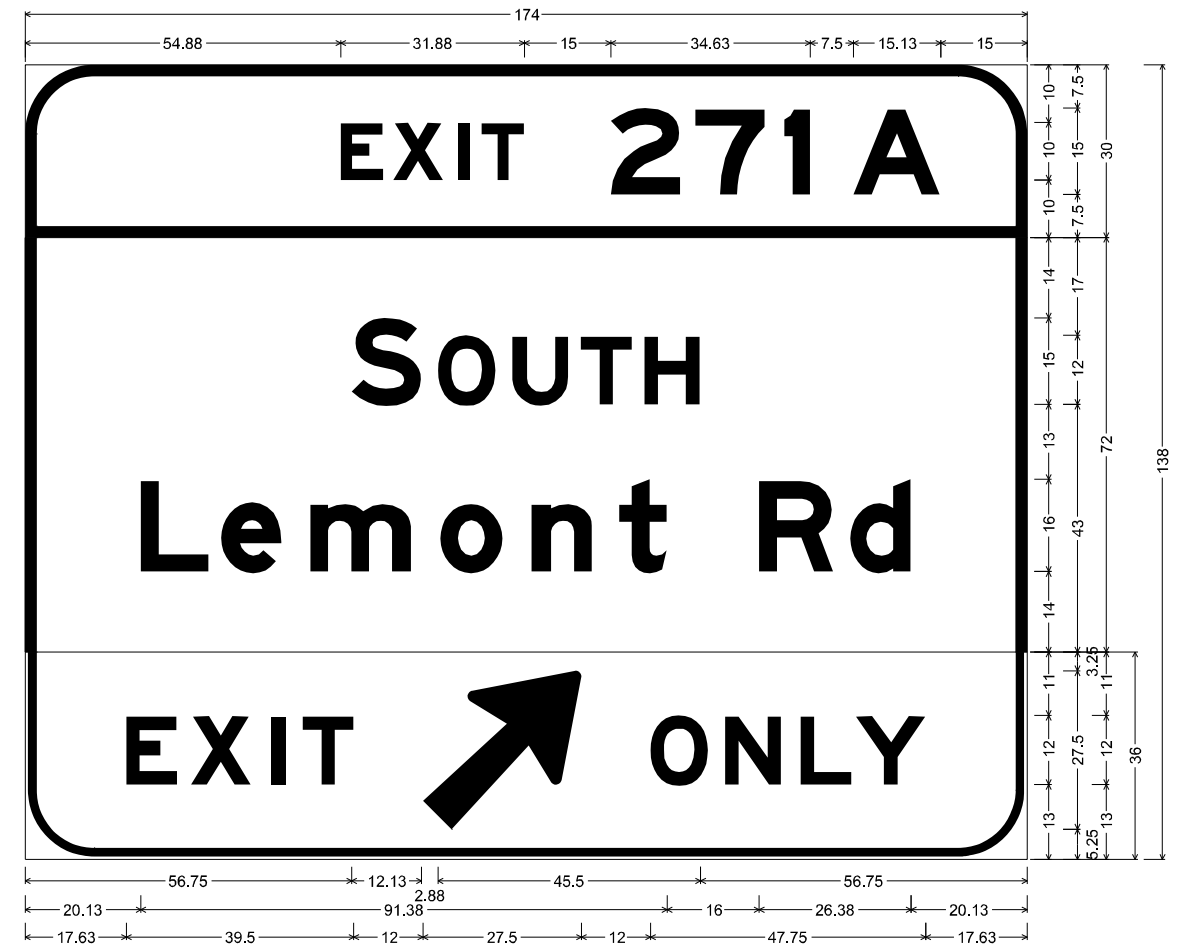

12.00" Radius, 2.00" Border, White on Green;  
 "EXIT", E Mod 2K 120% spacing; "271", E Mod 2K; "A", E Mod 2K;

12.00" Radius, 2.00" Border, White on Green;  
 "SOUTH", E Mod 2K; "Lemont Rd", E Mod 2K;

12.00" Radius, 1.50" Border, 0.50" Indent, Black on Yellow;  
 "EXIT", E Mod 2K specified length; Arrow 160 - 35.00" 45°; "ONLY", E Mod 2K specified length;

Table of widths and spaces

54.88	E	7.38	1.63	X	8.75	2.50	I	2.00	2.13	T	7.38	15.00	Z	12.25	2.50	7	12.13	3.38	I	4.50	7.50	A	15.13	15.00			
56.75	S	12.13	2.88	O	10.00	2.88	U	9.75	2.13	T	8.88	2.13	H	9.75	56.75												
20.13	L	11.88	2.00	e	10.63	4.88	m	17.63	5.00	o	10.88	4.88	n	10.63	4.63	t	8.25	16.00	R	13.00	2.88	d	10.63	20.13			
17.63	E	8.88	2.38	X	10.38	3.50	I	2.38	3.13	T	8.88	11.88	O	27.63	12.00	O	10.00	2.88	N	9.75	3.38	L	8.88	0.75	Y	12.13	17.50

MODEL: D:\p\p\Design\KKS\Signs - Design\Contract-48546-Signs-Structure-Design-155-And-1200-County-4-Enc-84-cc-Webster-Rd\CD\62P27155\_Signs\Color-KK-CO\BIBED-06-28-21.com  
 FILE NAME: S:\P\Design\KKS\Signs - Design\Contract-48546-Signs-Structure-Design-155-And-1200-County-4-Enc-84-cc-Webster-Rd\CD\62P27155\_Signs\Color-KK-CO\BIBED-06-28-21.com

USER NAME = plascenciaj	DESIGNED - KK	REVISED -
DRAWN - KK / IP	REVISOR -	
PLOT SCALE = 40,0000 * / in.	CHECKED - LP	REVISOR -
PLOT DATE = 7/1/2021	DATE - 06/25/2021	REVISOR -

**STATE OF ILLINOIS  
DEPARTMENT OF TRANSPORTATION**

**SIGN PANEL DESIGN**

SCALE:	SHEET	OF	SHEETS	STA.	TO	STA.
--------	-------	----	--------	------	----	------

F.A.I. RTE.	SECTION	COUNTY	TOTAL SHEETS	SHEET NO.
55	2021-128-SG	VARIOUS	178	114
CONTRACT NO. 62P27				
ILLINOIS FED. AID PROJECT				

STRUCTURE NUMBER		1S022I055R270.4-000	
LOCATION		66A	EXPRESSWAY
SIZE (W x H)	EXIT PLAQUE	-	
	MAIN PANEL	14' X 12'	
MOUNTING / TYPE		OVERHEAD / TRUSS	
MOUNTING LOC (L, M, R)		LEFT	
SHEETING / COLOR	BACKGROUND	TYPE:	ZZ
		COLOR:	GREEN
		TYPE:	
	LEGEND / BORDER	TYPE:	ZZ
		COLOR:	WHITE
		TYPE:	

STRUCTURE NUMBER		1S022I055R270.4-000	
LOCATION		66B	EXPRESSWAY
SIZE (W x H)	EXIT PLAQUE	-	
	MAIN PANEL	14.5' X 13.5'	
MOUNTING / TYPE		OVERHEAD / TRUSS	
MOUNTING LOC (L, M, R)		RIGHT	
SHEETING / COLOR	BACKGROUND	TYPE:	ZZ
		COLOR:	GREEN
		TYPE:	
	LEGEND / BORDER	TYPE:	ZZ
		COLOR:	WHITE
		TYPE:	

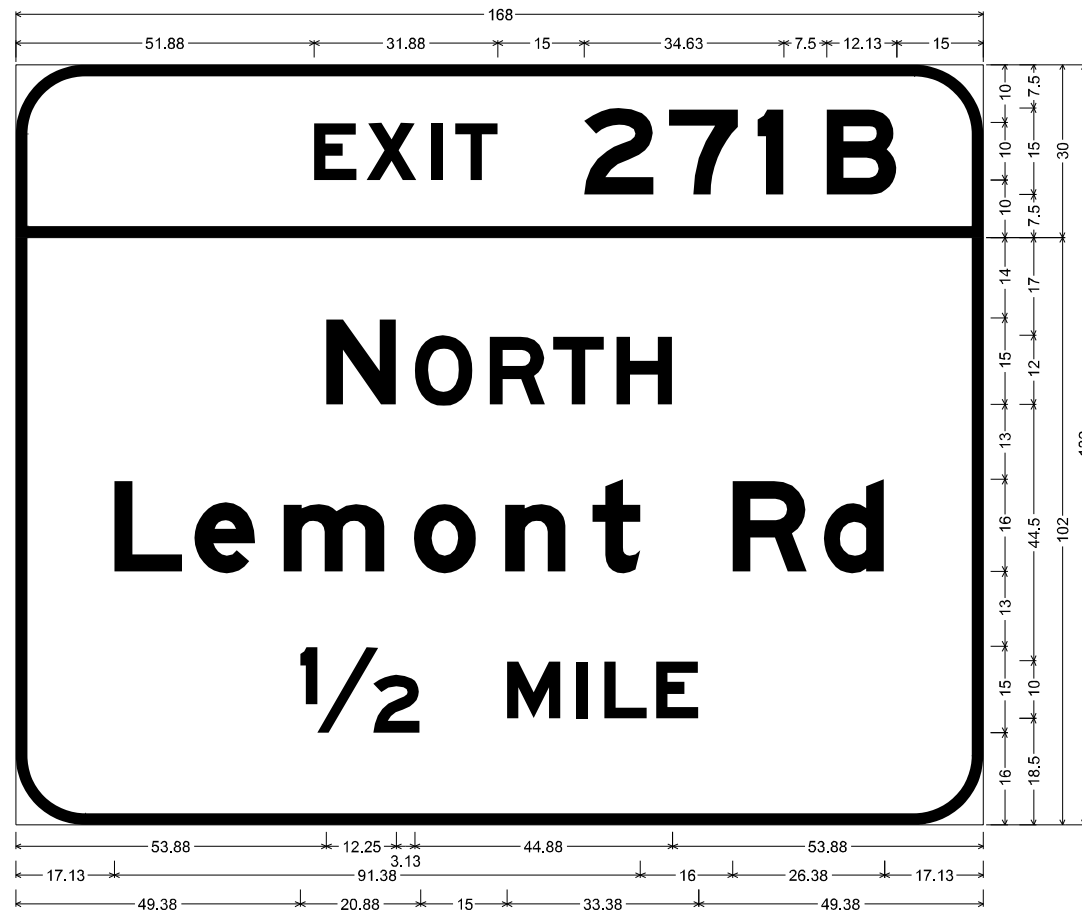

12.00" Radius, 2.00" Border, White on Green;  
 "EXIT", E Mod 2K 120% spacing; "271", E Mod 2K; "B", E Mod 2K;

12.00" Radius, 2.00" Border, White on Green;  
 "NORTH", E Mod 2K; "Lemont Rd", E Mod 2K; "1/2 MILE", E Mod 2K;

Table of widths and spaces

51.88	E	7.38	X	1.63	8.75	I	2.50	2.00	2.13	T	7.38	15.00	Z	12.25	2.50	7	12.13	3.38	1	4.50	7.50	B	12.13	15.00
53.88	N	12.25	O	3.13	10.13	R	2.88	9.75	1.25	T	8.88	2.25	H	9.63	54.00									
17.13	L	11.88	e	2.00	10.63	m	4.88	17.63	5.00	o	10.88	4.88	n	10.63	4.63	t	8.25	16.00	R	13.00	2.88	d	10.63	17.13
49.38	1/2	20.88	M	15.00	9.38	I	2.75	2.00	2.88	L	7.38	1.63	E	7.38	49.38									

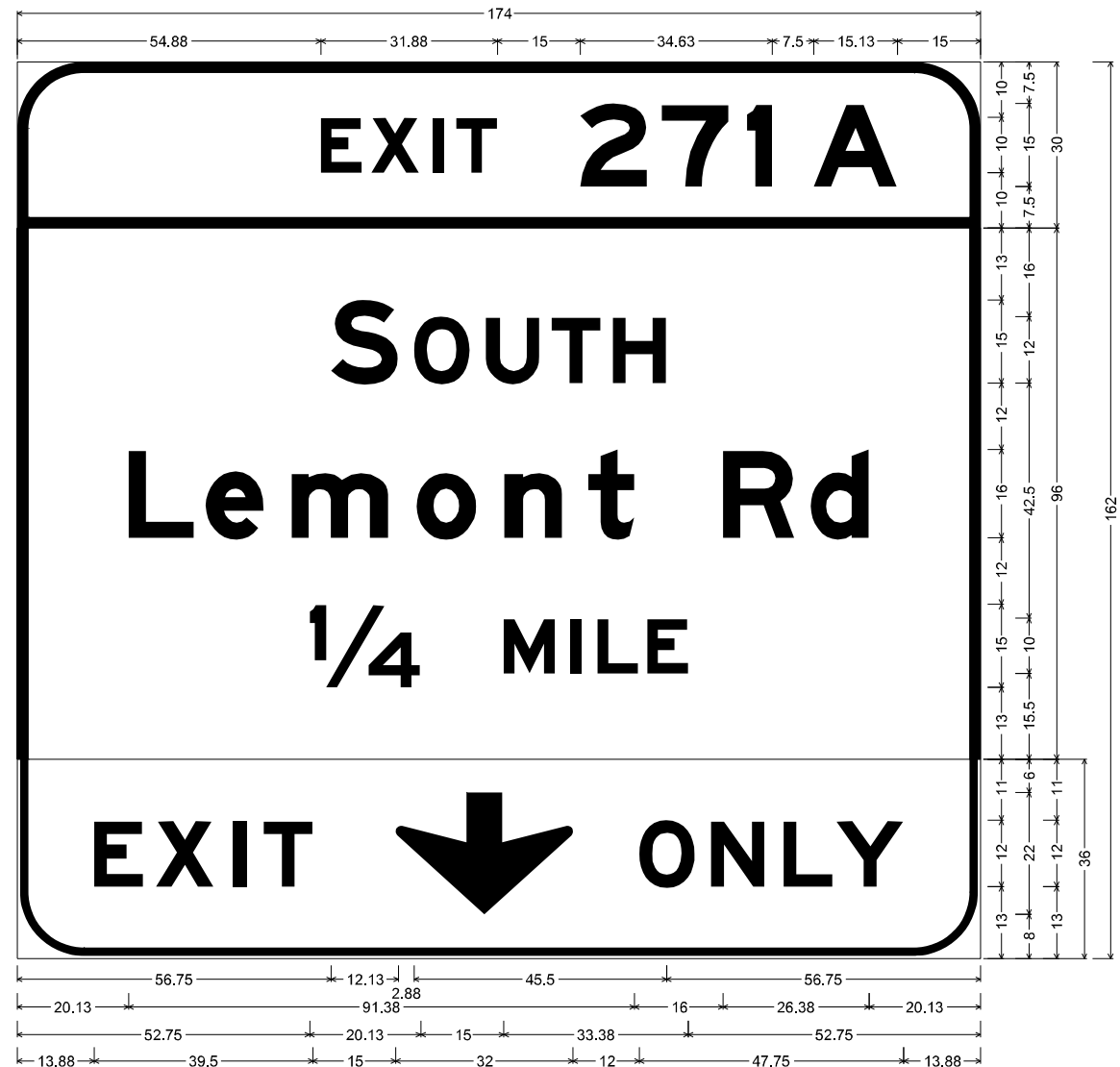

12.00" Radius, 2.00" Border, White on Green;  
 "EXIT", E Mod 2K 120% spacing; "271", E Mod 2K; "A", E Mod 2K;  
 12.00" Radius, 2.00" Border, White on Green;  
 "SOUTH", E Mod 2K; "Lemont Rd", E Mod 2K; "1/4 MILE", E Mod 2K;  
 12.00" Radius, 1.50" Border, 0.50" Indent, Black on Yellow;  
 "EXIT", E Mod 2K 140% spacing; Down Arrow 22.00" 270"; "ONLY", E Mod 2K;

Table of widths and spaces

54.88	E	7.38	X	1.63	8.75	I	2.00	2.13	T	7.38	15.00	Z	12.25	2.50	7	12.13	3.38	1	4.50	7.50	A	15.13	15.00				
56.75	S	12.13	O	2.88	10.00	U	9.75	2.13	T	8.88	2.13	H	9.75	56.75													
20.13	L	11.88	e	2.00	10.63	m	4.88	17.63	5.00	o	10.88	4.88	n	10.63	4.63	t	8.25	16.00	R	13.00	2.88	d	10.63	20.13			
52.75	1/4	20.13	M	15.00	9.38	I	2.00	2.75	L	7.50	1.50	E	7.50	52.75													
13.88	E	8.88	X	2.38	10.38	I	3.50	2.50	3.00	T	8.88	15.00	3/4	32.00	12.00	O	10.00	2.88	N	9.75	3.38	L	8.88	0.75	Y	12.13	13.88

MODEL: D:\p\h\... FILE NAME: S:\I\Design\KKS\Signs\_Design\Contract-46556-Signs\_Structure\Drawings\66A\66A271A55\_Signage\IP-KK-CO\BIBRED-06-28-21.dwg

USER NAME =	plascencia	DESIGNED -	KK	REVISED -	
DRAWN -	KK / IP	REVISIONS -		REVISED -	
PLOT SCALE =	40,0000 * / in.	CHECKED -	LP	REVISED -	
PLOT DATE =	7/1/2021	DATE -	06/25/2021	REVISED -	

STATE OF ILLINOIS  
DEPARTMENT OF TRANSPORTATION

SIGN PANEL DESIGN

SCALE: SHEET OF SHEETS STA. TO STA.

F.A.I. RTE.	SECTION	COUNTY	TOTAL SHEETS	SHEET NO.
55	2021-128-SG	VARIOUS	178	115
CONTRACT NO. 62P27				
ILLINOIS FED. AID PROJECT				

STRUCTURE NUMBER		1B022I055R269.8-000	
LOCATION		67 EXPRESSWAY	
SIZE (W x H)	EXIT PLAQUE	-	
	MAIN PANEL	15.5' X 8.5	
MOUNTING / TYPE		OVERHEAD / BRIDGE	
MOUNTING LOC (L, M, R)			
SHEETING / COLOR	BACKGROUND	TYPE:	ZZ
		COLOR:	GREEN
		TYPE:	
	LEGEND / BORDER	COLOR:	
		TYPE:	ZZ
		COLOR:	WHITE

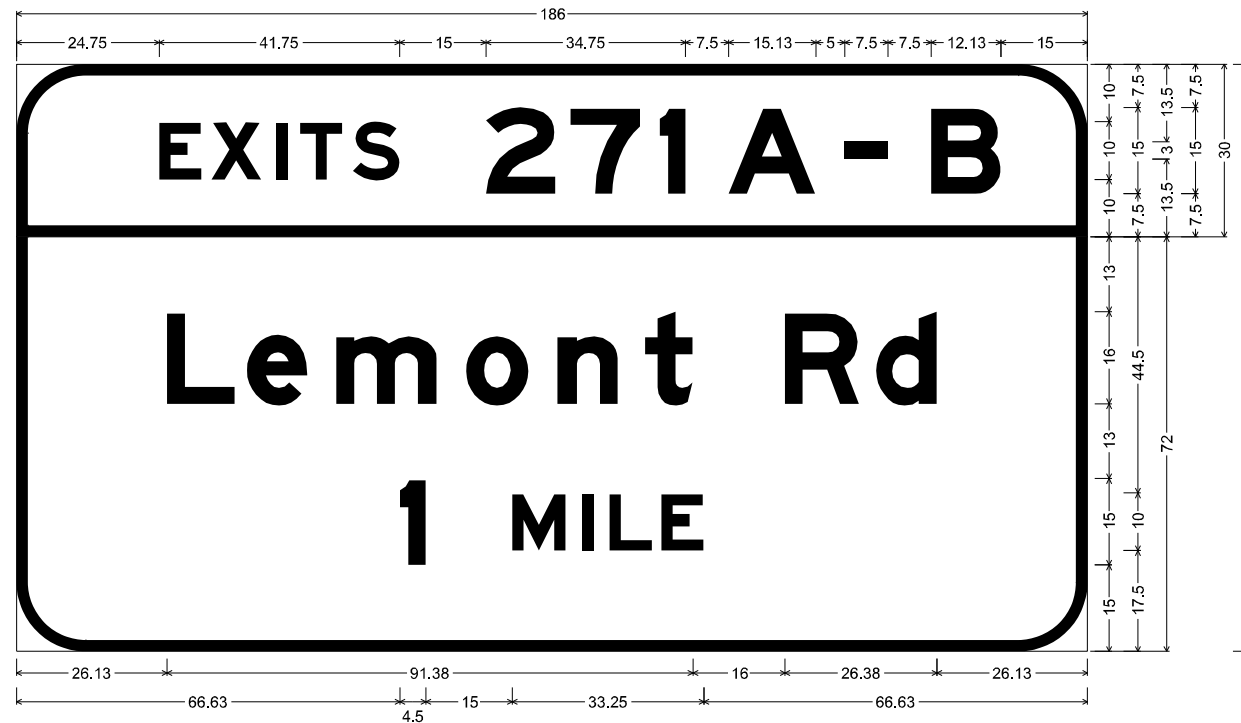

12.00" Radius, 2.00" Border, White on Green;  
 "EXITS", E Mod 2K 120% spacing; "271", E Mod 2K; "A", E Mod 2K; "B", E Mod 2K;

12.00" Radius, 2.00" Border, White on Green;  
 "Lemont Rd", E Mod 2K; "1 MILE", E Mod 2K;

Table of widths and spaces

24.75	E	7.50	1.63	X	8.75	2.50	I	2.00	2.13	T	7.38	1.75	S	8.13	15.00	Z	12.13	2.63	7	12.13	3.25	I	4.50	7.50	A	15.25	5.00	□	7.50	7.50	B	12.13	15.00
26.13	L	11.88	2.00	e	10.63	4.88	m	17.63	5.00	o	10.88	4.88	n	10.63	4.63	t	8.25	16.00	R	13.00	2.88	d	10.63	26.13									
66.63	1	4.50	15.00	M	9.25	2.88	I	2.00	2.75	L	7.38	1.63	E	7.38	66.63																		

MODEL: D:\p\p\Design\KKS\Signs Design\Contract-46556\Signs\Structure\Design-155\_and-1200-County\Line-84-co\Wagon-Rd\CDD\62P27-155\_Signage\IP-KK-COMBINED-06-28-21.dwg  
 FILE NAME: Sign\IP\Design\KKS\Signs Design\Contract-46556\Signs\Structure\Design-155\_and-1200-County\Line-84-co\Wagon-Rd\CDD\62P27-155\_Signage\IP-KK-COMBINED-06-28-21.dwg

USER NAME = plascencjal	DESIGNED - KK	REVISED -
	DRAWN - KK / IP	REVISED -
PLOT SCALE = 40,0000 * / in.	CHECKED - LP	REVISED -
PLOT DATE = 7/1/2021	DATE - 06/25/2021	REVISED -

**STATE OF ILLINOIS  
DEPARTMENT OF TRANSPORTATION**

**SIGN PANEL DESIGN**

SCALE: SHEET OF SHEETS STA. TO STA.

F.A.I. RTE.	SECTION	COUNTY	TOTAL SHEETS	SHEET NO.
55	2021-128-5G	VARIOUS	178	116
CONTRACT NO. 62P27			ILLINOIS FED. AID PROJECT	



**DETAILS**

"TOLL" PLAQUE DETAIL DESIGN

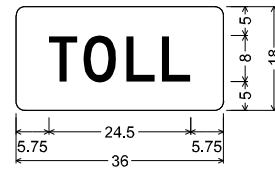

1.50" Radius, 0.00" Border, White on Yellow;

"TOLL" Black, D 2K;

Table of widths and spaces

T	4.88	1.13	O	5.63	1.75	L	5.00	1.13	L	5.00	5.75
---	------	------	---	------	------	---	------	------	---	------	------

STRUCTURE NUMBER		1S0991055R269.0-000	
LOCATION		68A EXPRESSWAY	
SIZE (W x H)	EXIT PLAQUE	-	
	MAIN PANEL	17' X 13'	
MOUNTING / TYPE		OVERHEAD / TRUSS	
MOUNTING LOC (L, M, R)		LEFT	
SHEETING / COLOR	BACKGROUND	TYPE:	ZZ
		COLOR:	GREEN
		TYPE:	
	LEGEND / BORDER	TYPE:	ZZ
		COLOR:	WHITE
		TYPE:	

**DETAILS**

"TOLL" PLAQUE DETAIL DESIGN

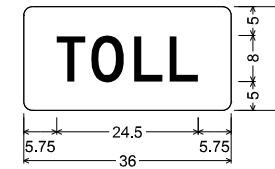

1.50" Radius, 0.00" Border, White on Yellow;

"TOLL" Black, D 2K;

Table of widths and spaces

T	4.88	1.13	O	5.63	1.75	L	5.00	1.13	L	5.00	5.75
---	------	------	---	------	------	---	------	------	---	------	------

STRUCTURE NUMBER		1S0991055R269.0-000	
LOCATION		68B EXPRESSWAY	
SIZE (W x H)	EXIT PLAQUE	-	
	MAIN PANEL	17' X 10'	
MOUNTING / TYPE		OVERHEAD / TRUSS	
MOUNTING LOC (L, M, R)		RIGHT	
SHEETING / COLOR	BACKGROUND	TYPE:	ZZ
		COLOR:	GREEN
		TYPE:	
	LEGEND / BORDER	TYPE:	ZZ
		COLOR:	WHITE
		TYPE:	

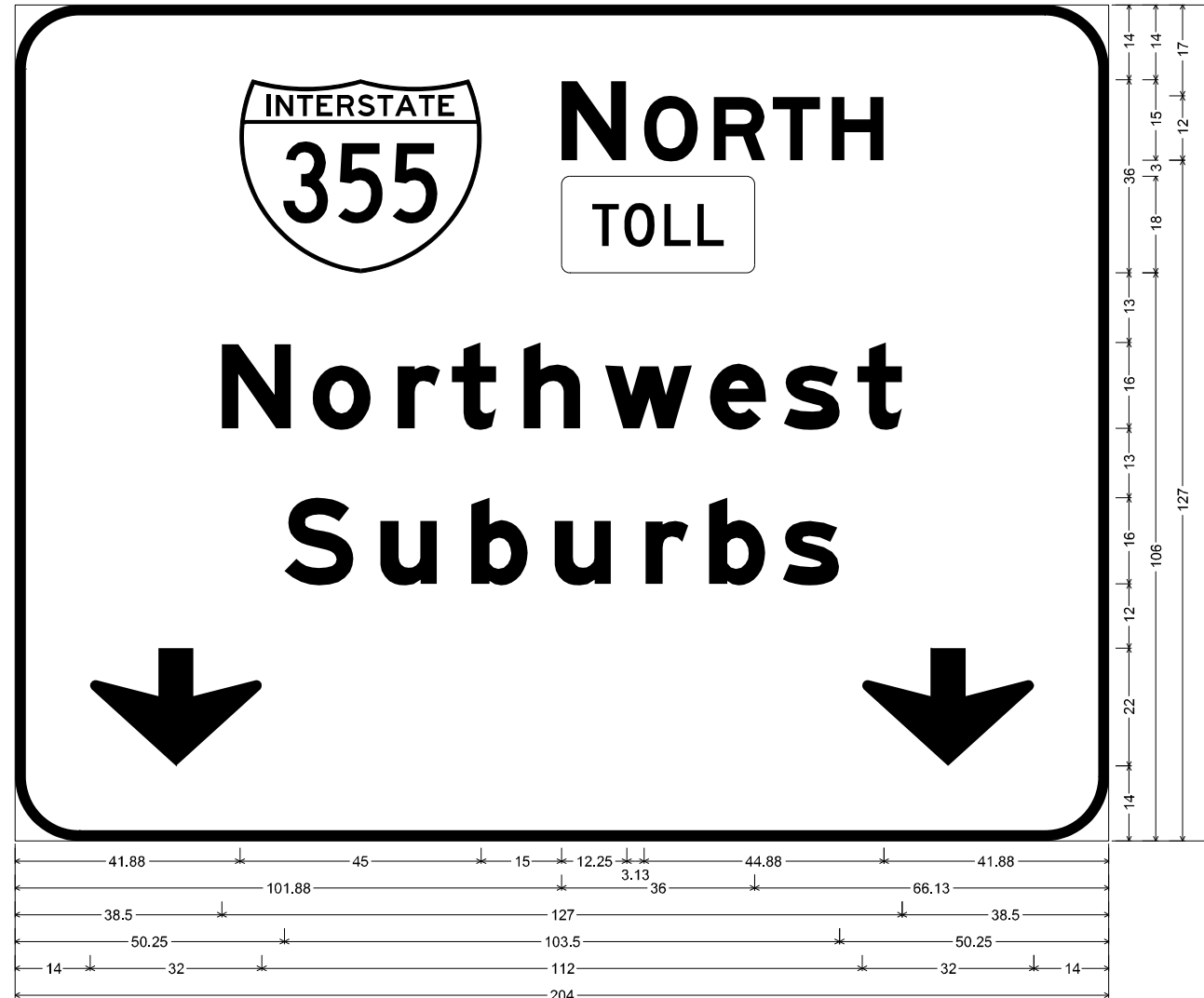

12.00" Radius, 2.00" Border, White on Green;

"NORTH", E Mod 2K; Rounded Rectangle 1.50" Radius Yellow;

"Northwest", E Mod 2K; "Suburbs", E Mod 2K; Down Arrow 22.00" 270";

Table of widths and spaces

41.88	45.00	15.00	N	12.25	3.13	O	10.13	2.88	R	9.75	1.25	T	8.88	2.25	H	9.63	42.00										
101.88	36.00	66.13																									
38.50	13.00	4.00	o	10.88	5.00	r	8.00	2.00	t	8.38	5.13	h	10.50	4.75	w	16.25	3.25	e	10.50	3.25	s	10.50	3.25	t	8.25	38.63	
50.25	13.00	4.88	u	10.63	6.38	b	10.50	5.00	u	10.50	6.50	r	8.00	3.75	b	10.63	3.13	s	10.63	50.25							
14.00	32.00	112.00	32.00	14.00																							

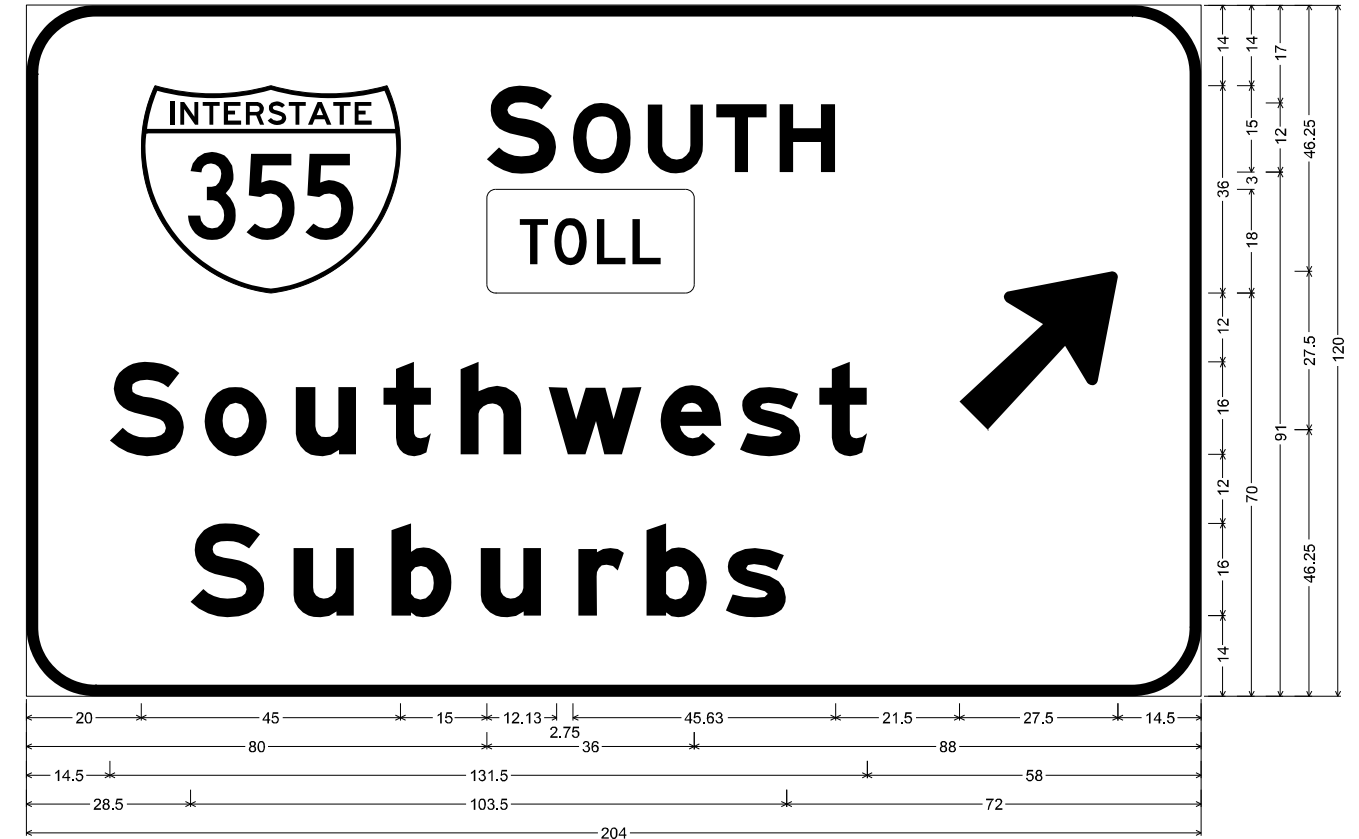

12.00" Radius, 2.00" Border, White on Green;

"SOUTH", E Mod 2K; Rounded Rectangle 1.50" Radius Yellow;

"Southwest", E Mod 2K; "Suburbs", E Mod 2K; Arrow 160 - 35.00" 45";

Table of widths and spaces

20.00	45.00	15.00	S	12.13	2.75	O	10.13	2.88	U	9.75	2.13	T	8.88	2.13	H	9.75	21.50	27.50	14.50							
80.00	36.00	88.00																								
14.50	13.00	3.50	o	10.88	4.88	u	10.63	4.63	t	8.25	5.13	h	10.63	4.63	w	16.25	3.25	e	10.50	3.25	s	10.63	3.13	t	8.38	58.00
28.50	13.00	4.88	u	10.63	6.38	b	10.50	5.00	u	10.50	6.50	r	8.00	3.75	b	10.63	3.13	s	10.63	72.00						

MODEL: D:\p\p\... FILE NAME: SW\... DESIGNER: KK/Sims DESIGN: Design\Contract-48556-Sims\Structure\Design-155-and-1200-County\4-Enc-84-cc-Webster-Rd\CADD\62P27155\_Signage\IP-KK-CO\BIBED-06-28-21.dwg

USER NAME = plascenciaj	DESIGNED - KK	REVISED -
DRAWN - KK / IP	REVISIONS -	
PLOT SCALE = 40,0000 * / in.	CHECKED - LP	REVISED -
PLOT DATE = 7/1/2021	DATE - 06/25/2021	REVISED -

**STATE OF ILLINOIS  
DEPARTMENT OF TRANSPORTATION**

**SIGN PANEL DESIGN**

SCALE: SHEET OF SHEETS STA. TO STA.

F.A.I. RTE.	SECTION	COUNTY	TOTAL SHEETS	SHEET NO.
55	2021-128-SG	VARIOUS	178	117
CONTRACT NO. 62P27				
ILLINOIS FED. AID PROJECT				

STRUCTURE NUMBER		1C0991055R268.5-000
LOCATION		69 EXPRESSWAY
SIZE (W x H)	EXIT PLAQUE	-
	MAIN PANEL	26.5' X 14'
MOUNTING / TYPE		OVERHEAD / CANTILEVER
MOUNTING LOC (L, M, R)		
SHEETING / COLOR	BACKGROUND	TYPE: ZZ
		COLOR: GREEN
		TYPE:
		COLOR:
	LEGEND / BORDER	TYPE: ZZ
		COLOR: WHITE
		TYPE:
		COLOR:

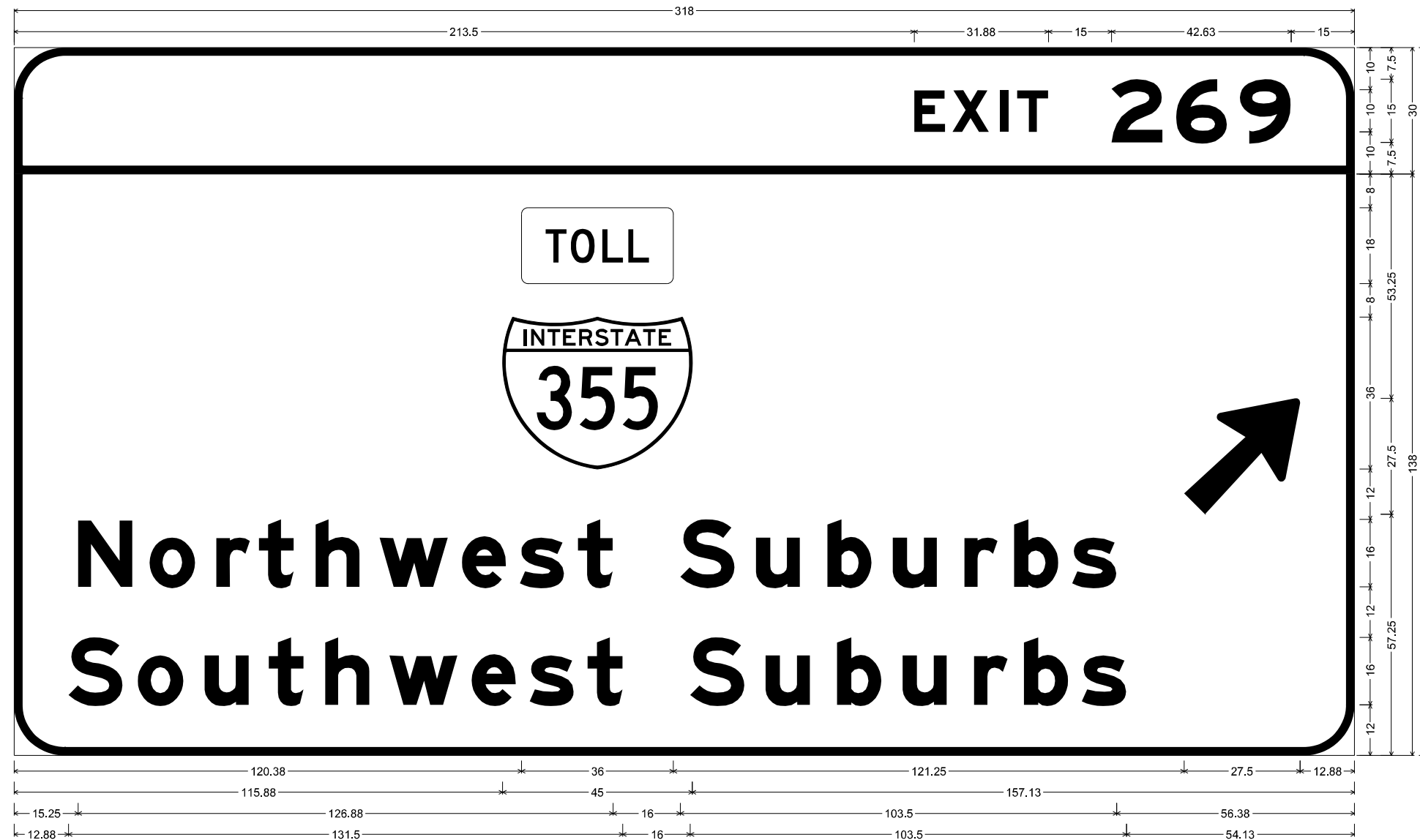

**DETAILS**

"TOLL" PLAQUE DETAIL DESIGN

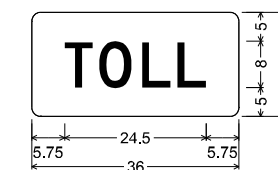

1.50" Radius, 2.00" Border, White on Yellow;  
 "TOLL" Black, D 2K;

Table of widths and spaces

5.75	T	4.88	1.13	O	5.63	1.75	L	5.00	1.13	L	5.00	5.75
------	---	------	------	---	------	------	---	------	------	---	------	------

12.00" Radius, 2.00" Border, White on Green;  
 "EXIT", E Mod 2K 120% spacing; "269", E Mod 2K;

12.00" Radius, 2.00" Border, White on Green;  
 Rounded Rectangle 1.50" Radius Yellow;  
 "Northwest Suburbs", E Mod 2K; "Southwest Suburbs", E Mod 2K; Arrow 160 - 35.00" 45";

Table of widths and spaces

213.50	E	7.50	1.63	X	8.75	2.50	I	2.00	2.13	T	7.38	15.00	Z	12.13	3.13	6	12.25	3.00	9	12.13	15.00																											
120.38		36.00			27.50	12.88																																										
115.88		45.00			157.13																																											
15.25	N	12.88	4.00	o	10.88	5.00	r	8.00	2.13	t	8.25	5.13	h	10.50	4.75	w	16.25	3.25	e	10.50	3.25	s	10.50	3.25	t	8.25	16.00	S	13.00	5.00	u	10.50	6.50	b	10.50	5.00	u	10.50	6.38	8.00	3.88	b	10.50	3.25	s	10.63	56.38	
12.88	S	13.00	3.50	o	10.88	5.00	u	10.50	4.63	t	8.38	5.13	h	10.50	4.63	w	16.38	3.13	e	10.63	3.13	s	10.63	3.13	t	8.38	16.00	S	12.88	5.00	u	10.50	6.50	b	10.50	5.00	u	10.50	6.50	r	8.00	3.75	b	10.63	3.13	s	10.63	54.00

MODEL: D:\p\p\...  
 FILE NAME: ...  
 PROJECT: ...  
 CONTRACT: ...  
 DESIGNER: ...  
 DATE: ...

USER NAME = plascencia	DESIGNED - KK	REVISED -
DRAWN - KK / IP	REVISIONS -	
PLOT SCALE = 40,0000 * / in.	CHECKED - LP	REVISED -
PLOT DATE = 7/1/2021	DATE - 06/25/2021	REVISED -

**STATE OF ILLINOIS  
 DEPARTMENT OF TRANSPORTATION**

**SIGN PANEL DESIGN**

SCALE: SHEET OF SHEETS STA. TO STA.

F.A.I. RTE.	SECTION	COUNTY	TOTAL SHEETS	SHEET NO.
55	2021-128-SG	VARIOUS	178	118
CONTRACT NO. 62P27			ILLINOIS FED. AID PROJECT	

STRUCTURE NUMBER		1S0991055R268.5-000
LOCATION		70A EXPRESSWAY
SIZE (W x H)	EXIT PLAQUE	-
	MAIN PANEL	10.5' X 9.5'
MOUNTING / TYPE		OVERHEAD / TRUSS
MOUNTING LOC (L, M, R)		LEFT
SHEETING / COLOR	BACKGROUND	TYPE: ZZ
		COLOR: GREEN
		TYPE:
		COLOR:
	LEGEND / BORDER	TYPE: ZZ
		COLOR: WHITE
		TYPE:
		COLOR:

**DETAILS**

"TOLL" PLAQUE DETAIL DESIGN

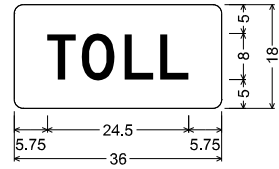

1.50" Radius, 0.00" Border, White on Yellow;  
"TOLL" Black, D 2K;

Table of widths and spaces

5.75	T	4.88	1.13	O	5.63	1.75	L	5.00	1.13	L	5.00	5.75
------	---	------	------	---	------	------	---	------	------	---	------	------

STRUCTURE NUMBER		1S0991055R268.5-000
LOCATION		70B EXPRESSWAY
SIZE (W x H)	EXIT PLAQUE	-
	MAIN PANEL	9.5' X 11'
MOUNTING / TYPE		OVERHEAD / TRUSS
MOUNTING LOC (L, M, R)		RIGHT
SHEETING / COLOR	BACKGROUND	TYPE: ZZ
		COLOR: GREEN
		TYPE:
		COLOR:
	LEGEND / BORDER	TYPE: ZZ
		COLOR: WHITE
		TYPE:
		COLOR:

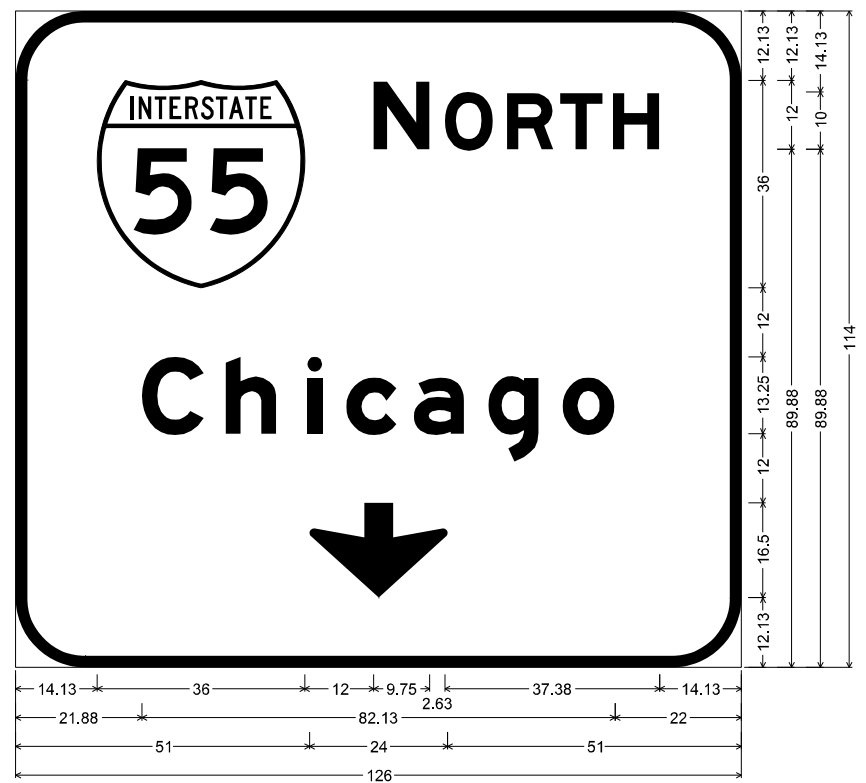

12.00" Radius, 2.00" Border, White on Green;  
"NORTH", E Mod 2K; "Chicago", E Mod 2K; Down Arrow Custom - 16.50" 270";

Table of widths and spaces

14.13	36.00	12.00	N	9.75	2.63	O	8.38	2.50	R	8.00	1.13	T	7.38	1.88	H	8.00	14.25			
21.88	10.88	3.75	h	8.75	5.38	i	2.63	4.13	c	8.75	3.00	a	8.75	4.13	g	8.88	4.13	o	9.00	22.00
51.00	24.00	51.00																		

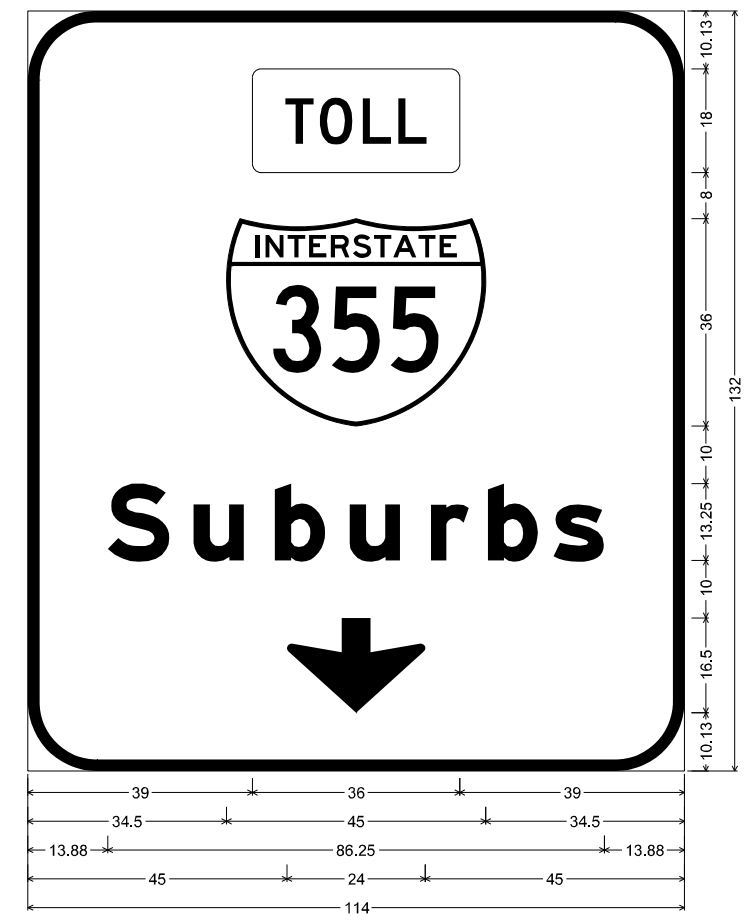

12.00" Radius, 2.00" Border, White on Green;  
Rounded Rectangle 1.50" Radius Yellow;

"Suburbs", E Mod 2K; Down Arrow Custom - 16.50" 270";

Table of widths and spaces

39.00	36.00	39.00																			
34.50	45.00	34.50																			
13.88	10.75	4.13	S	8.88	5.25	8.88	4.13	8.75	5.38	6.63	3.25	8.75	2.63	8.88	13.88						
45.00	24.00	45.00																			

MODEL: D:\p\p\Design\KKS\Sigms\_Design\Contract-46556\Sigs\_Structure\Design-155\and-1200-County\46556-84-cc\Worcr-Rpt\CADD\62P27-155\_Sigms\c-IP-KK-CO\BIBED-06-28-21.dwg  
FILE NAME: S:\P\Design\KKS\Sigms\_Design\Contract-46556\Sigs\_Structure\Design-155\and-1200-County\46556-84-cc\Worcr-Rpt\CADD\62P27-155\_Sigms\c-IP-KK-CO\BIBED-06-28-21.dwg

USER NAME = plascncial	DESIGNED - KK	REVISED -
DRAWN - KK / IP	REVISIONS -	
PLOT SCALE = 40,0000 * / in.	CHECKED - LP	REVISED -
PLOT DATE = 7/1/2021	DATE - 06/25/2021	REVISED -

**STATE OF ILLINOIS  
DEPARTMENT OF TRANSPORTATION**

**SIGN PANEL DESIGN**

SCALE:	SHEET	OF	SHEETS	STA.	TO	STA.
--------	-------	----	--------	------	----	------

F.A.I. RTE.	SECTION	COUNTY	TOTAL SHEETS	SHEET NO.
55	2021-128-5G	VARIOUS	178	119
				CONTRACT NO. 62P27
		ILLINOIS	FED. AID PROJECT	

**DETAILS**

"TOLL" PLAQUE DETAIL DESIGN

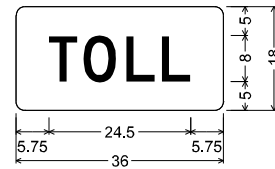

1.50" Radius, 0.00" Border, White on Yellow;

"TOLL" Black, D 2K;

Table of widths and spaces

5.75	T	4.88	1.13	O	5.63	1.75	L	5.00	1.13	L	5.00	5.75
------	---	------	------	---	------	------	---	------	------	---	------	------

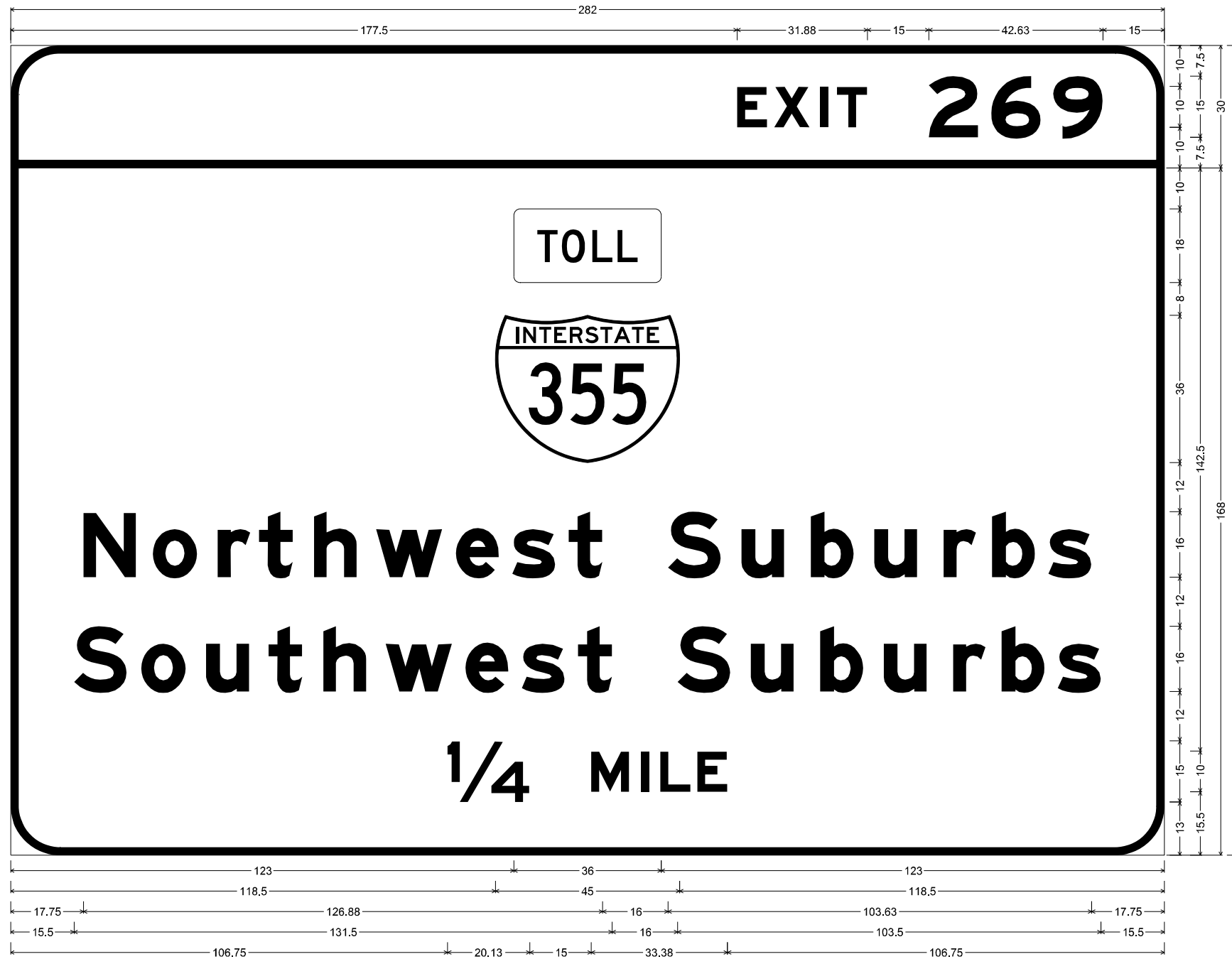

12.00" Radius, 2.00" Border, White on Green;

"EXIT", E Mod 2K 120% spacing; "269", E Mod 2K;

12.00" Radius, 2.00" Border, White on Green;

Rounded Rectangle 1.50" Radius Yellow;

"Northwest Suburbs", E Mod 2K; "Southwest Suburbs", E Mod 2K; "1/4 MILE", E Mod 2K;

Table of widths and spaces

177.50	E	7.50	X	1.63	8.75	2.50	I	2.00	2.13	T	7.38	15.00	Z	12.13	3.13	6	12.25	3.00	9	12.13	15.00																														
123.00		36.00		123.00																																															
118.50		45.00		118.50																																															
17.75	N	13.00	4.00	o	10.88	5.00	r	8.00	2.00	t	8.38	5.13	h	10.50	4.63	w	16.38	3.25	e	10.50	3.25	s	10.50	3.25	t	8.25	16.00	S	13.00	5.00	u	10.50	6.38	b	10.63	4.88	u	10.63	6.38	r	8.00	3.88	b	10.50	3.25	s	10.50	17.88			
15.50	S	13.00	3.50	o	10.88	4.88	u	10.63	4.63	t	8.25	5.13	h	10.63	4.63	w	16.25	3.25	e	10.50	3.25	s	10.63	3.13	t	8.38	16.00	S	12.88	5.00	u	10.50	6.50	b	10.50	5.00	u	10.50	6.38	r	8.00	3.88	b	10.63	3.13	s	10.63	15.38			
106.75	1/4	20.13	15.00	M	9.38	2.75	I	2.00	2.75	L	7.50	1.50	E	7.50	106.75																																				

STRUCTURE NUMBER		1C0991055R268.2-000
LOCATION		71 EXPRESSWAY
SIZE (W x H)	EXIT PLAQUE	-
	MAIN PANEL	23.5' X 16.5'
MOUNTING / TYPE		OVERHEAD / CANTILEVER
MOUNTING LOC (L, M, R)		
SHEETING / COLOR	BACKGROUND	TYPE: ZZ
		COLOR: GREEN
	LEGEND / BORDER	TYPE: ZZ
		COLOR: WHITE
		COLOR:

MODEL: D:\p\p\Design\KKS\Signs Design\Contract-46556-Signs-Structure-Design-155-and-1200-County-4-Enc-84-co-Water-Boi\00DD\62P27155\_Signs\c-IP-KK-CO\BIBED-06-28-21.com

USER NAME = plascencjal	DESIGNED - KK	REVISED -
DRAWN - KK / IP	REVISED -	
PLOT SCALE = 40,0000 * / in.	CHECKED - LP	REVISED -
PLOT DATE = 7/1/2021	DATE - 06/25/2021	REVISED -

**STATE OF ILLINOIS  
DEPARTMENT OF TRANSPORTATION**

<b>SIGN PANEL DESIGN</b>				
SCALE:	SHEET	OF	SHEETS	STA. TO STA.

F.A.I. RTE.	SECTION	COUNTY	TOTAL SHEETS	SHEET NO.
55	2021-128-SG	VARIOUS	178	120
CONTRACT NO. 62P27				
ILLINOIS FED. AID PROJECT				

**DETAILS**

"TOLL" PLAQUE DETAIL DESIGN

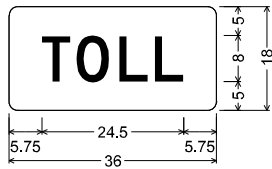

1.50" Radius, 0.00" Border, White on Yellow;

"TOLL" Black, D 2K;

Table of widths and spaces

5.75	T	4.88	1.13	O	5.63	1.75	L	5.00	1.13	L	5.00	5.75
------	---	------	------	---	------	------	---	------	------	---	------	------

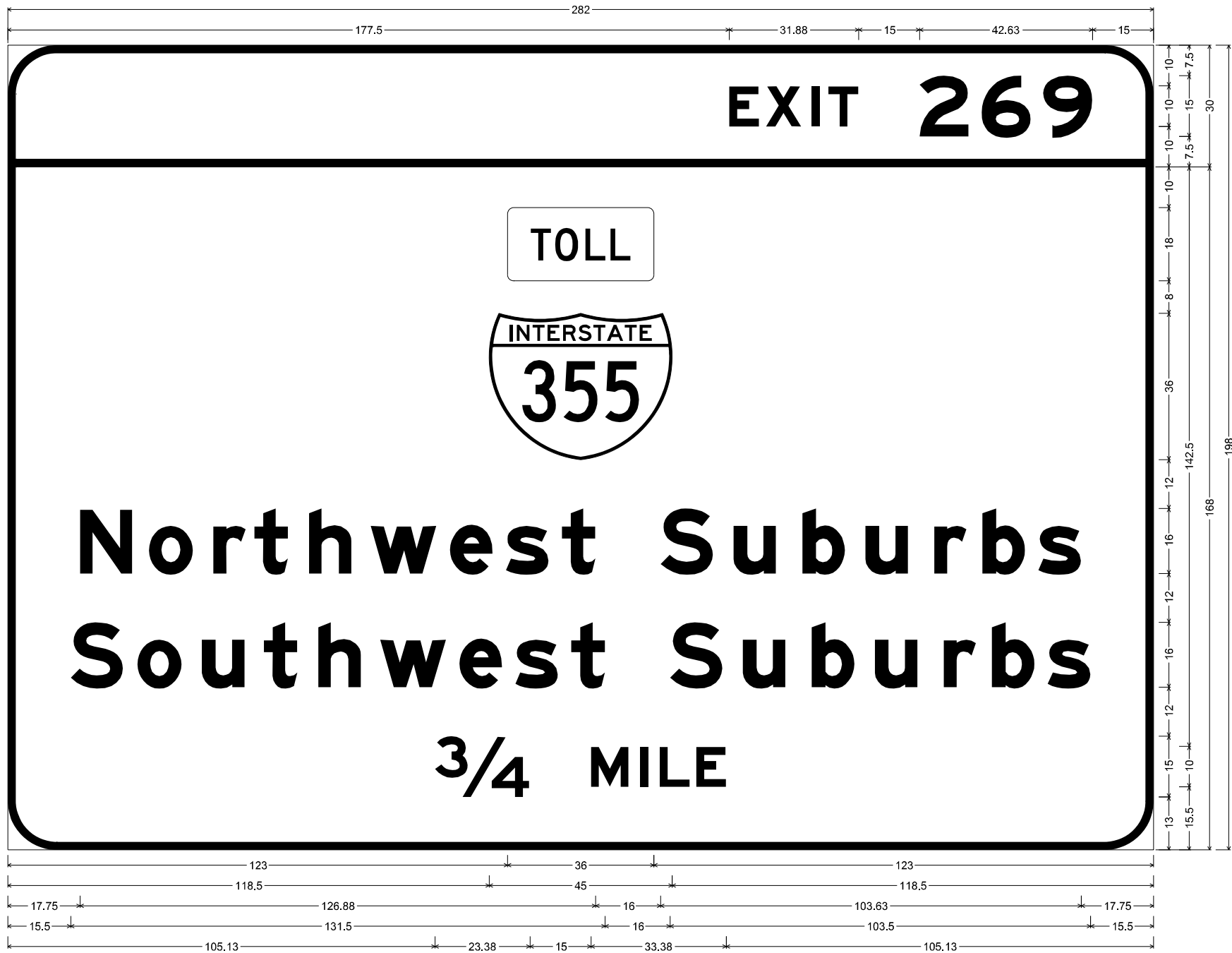

12.00" Radius, 2.00" Border, White on Green;  
 "EXIT", E Mod 2K 120% spacing; "269", E Mod 2K;

12.00" Radius, 2.00" Border, White on Green;  
 Rounded Rectangle 1.50" Radius Yellow;  
 "Northwest Suburbs", E Mod 2K; "Southwest Suburbs", E Mod 2K; "3/4 MILE", E Mod 2K;

Table of widths and spaces

177.50	E	7.50	X	1.63	8.75	2.50	I	2.00	2.13	T	7.38	15.00	Z	12.13	3.13	6	12.25	3.00	9	12.13	15.00																											
123.00	36.00		123.00																																													
118.50	45.00		118.50																																													
17.75	N	13.00	4.00	o	10.88	5.00	r	8.00	2.00	t	8.38	5.13	h	10.50	4.63	w	16.38	3.25	e	10.50	3.25	s	10.50	3.25	t	8.25	16.00	S	13.00	5.00	u	10.50	6.38	b	10.63	4.88	u	10.63	6.38	r	8.00	3.88	b	10.50	3.25	s	10.50	17.88
15.50	S	13.00	3.50	o	10.88	4.88	u	10.63	4.63	t	8.25	5.13	h	10.63	4.63	w	16.25	3.25	e	10.50	3.25	s	10.63	3.13	t	8.38	16.00	S	12.88	5.00	u	10.50	6.50	b	10.50	5.00	u	10.50	6.38	r	8.00	3.88	b	10.63	3.13	s	10.63	15.38
105.13	3/4	23.38	15.00	M	9.38	2.75	I	2.00	2.75	L	7.50	1.50	E	7.50	105.13																																	

STRUCTURE NUMBER	1C0991055R267.8-000		
LOCATION	72	EXPRESSWAY	
SIZE (W x H)	EXIT PLAQUE	-	
	MAIN PANEL	23.5' X 16.5'	
MOUNTING / TYPE	OVERHEAD / CANTILEVER		
MOUNTING LOC (L, M, R)			
SHEETING / COLOR	BACKGROUND	TYPE:	ZZ
		COLOR:	GREEN
		TYPE:	
		COLOR:	
	LEGEND / BORDER	TYPE:	ZZ
		COLOR:	WHITE
		TYPE:	
		COLOR:	

MODEL: D:\p\p\Design\KKS\Signs Design\Contract-46556-Signs-Structure-Design-155-and-1200-County-4-Enc-84-co-Webor-Rn\COADD\61272155\_Signs-IP-KK-COMBINED-06-28-21.dwg

USER NAME = plascencjal	DESIGNED - KK	REVISED -
DRAWN - KK / IP	REVISED -	
PLOT SCALE = 40,0000 * / in.	CHECKED - LP	REVISED -
PLOT DATE = 7/1/2021	DATE - 06/25/2021	REVISED -

**STATE OF ILLINOIS  
DEPARTMENT OF TRANSPORTATION**

**SIGN PANEL DESIGN**

SCALE: SHEET OF SHEETS STA. TO STA.

F.A.I. RTE.	SECTION	COUNTY	TOTAL SHEETS	SHEET NO.
55	2021-128-SG	VARIOUS	178	121
CONTRACT NO. 62P27				
ILLINOIS FED. AID PROJECT				

STRUCTURE NUMBER		1S0991055R266.8-000	
LOCATION		73 EXPRESSWAY	
SIZE (W x H)	EXIT PLAQUE	-	
	MAIN PANEL	18.5' X 13'	
MOUNTING / TYPE		OVERHEAD / TRUSS	
MOUNTING LOC (L, M, R)		RIGHT	
SHEETING / COLOR	BACKGROUND	TYPE:	ZZ
		COLOR:	GREEN
		TYPE:	
	LEGEND / BORDER	COLOR:	
		TYPE:	ZZ
		COLOR:	WHITE

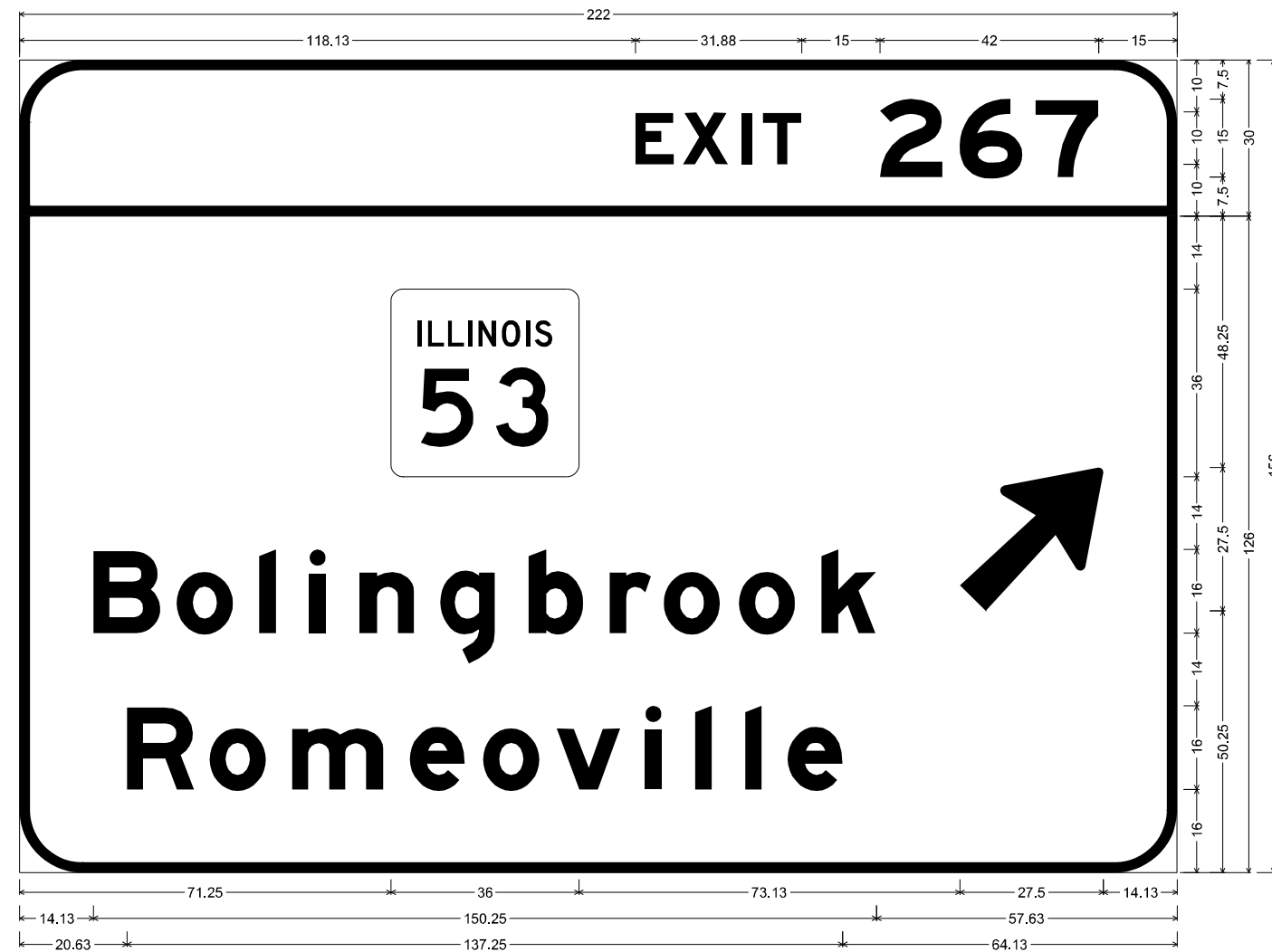

12.00" Radius, 2.00" Border, White on Green;  
 "EXIT", E Mod 2K 120% spacing; "267", E Mod 2K;  
 12.00" Radius, 2.00" Border, White on Green;  
 "Bolingbrook", E Mod 2K; "Romeoville", E Mod 2K; Arrow 160 - 35.00" 45";  
 Table of widths and spaces

118.13	E	7.38	1.75	X	8.63	2.50	I	2.00	2.25	T	7.38	15.00	Z	12.13	3.13	6	12.13	2.50	7	12.13	15.00												
71.25		36.00			73.13																												
14.13	B	13.00	3.00	o	10.88	5.00	i	3.13	6.38	i	3.25	6.38	n	10.63	4.88	g	10.63	6.38	b	10.50	5.00	r	8.00	2.38	o	10.88	3.50	o	10.88	5.00	k	10.50	57.75
20.63	R	12.88	2.88	o	10.88	5.00	m	17.63	5.00	e	10.50	3.50	o	10.88	3.25	v	12.25	4.63	i	3.25	6.38	3.25	6.38	3.25	6.38	3.25	4.88	e	10.63	64.13			

MODEL: D:\p\p\Design\KKS\Signs - Design\Contract-48556\Signs-Structure\Design-155\and-L200-County\4-Enc-84-co\W\enc-84-co\CADD\62P27-155\_Signs\csp-IP-KK-COM\BRED-06-28-21.dwg  
 FILE NAME: S:\IP\Design\KKS\Signs - Design\Contract-48556\Signs-Structure\Design-155\and-L200-County\4-Enc-84-co\W\enc-84-co\CADD\62P27-155\_Signs\csp-IP-KK-COM\BRED-06-28-21.dwg

USER NAME = plascencjal PLOT SCALE = 40,0000 */ in. PLOT DATE = 7/1/2021	DESIGNED - KK DRAWN - KK / IP CHECKED - LP DATE - 06/25/2021	REVISED - REVISED - REVISED - REVISED -	<b>STATE OF ILLINOIS          DEPARTMENT OF TRANSPORTATION</b>	<b>SIGN PANEL DESIGN</b>				F.A.I. RTE. 55 SECTION 2021-128-SG COUNTY VARIOUS TOTAL SHEETS 178 SHEET NO. 122
				SCALE: SHEET OF SHEETS STA. TO STA.	CONTRACT NO. 62P27 ILLINOIS FED. AID PROJECT			

STRUCTURE NUMBER		1C0991055R265.0-000	
LOCATION		74	EXPRESSWAY
SIZE (W x H)	EXIT PLAQUE	-	
	MAIN PANEL	13' X 5.5'	
MOUNTING / TYPE		OVERHEAD / CANTILEVER	
MOUNTING LOC (L, M, R)			
SHEETING / COLOR	BACKGROUND	TYPE:	ZZ
		COLOR:	GREEN
		TYPE:	
	LEGEND / BORDER	COLOR:	
		TYPE:	ZZ
		COLOR:	WHITE

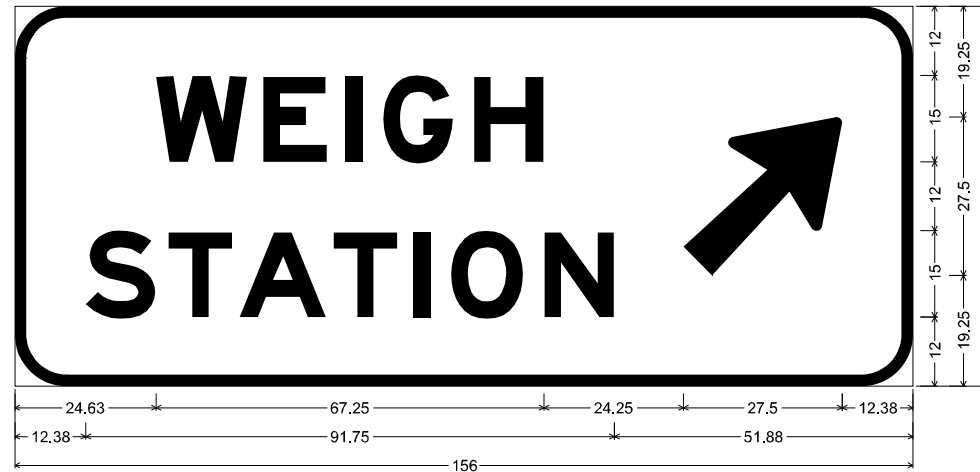

9.00" Radius, 2.00" Border, White on Green;  
 "WEIGH", E Mod 2K; "STATION", E Mod 2K; Arrow 160 - 35.00" 45";

Table of widths and spaces

24.63	W	15.88	2.63	E	11.13	3.13	I	3.00	3.63	G	12.13	3.63	H	12.13	24.25	↗	27.50	12.38			
12.38	S	12.13	2.25	T	11.13	1.13	A	15.13	1.25	T	11.13	2.63	I	3.00	3.63	O	12.63	3.63	N	12.13	51.88

MODEL: D:\p\h  
 FILE NAME: S:\IP\Design\KKS\Signs Design\Contract-48556\Signs\Structure\Design-155\_and-1200\County4\Enc-84-co\Wsign-R0\CADD\62P27-155\_Signs\IP-KK-COMBINED-06-28-21.dwg

USER NAME = plascencjal	DESIGNED - KK	REVISED -
DRAWN - KK / IP	REVISOR -	
PLOT SCALE = 40,0000 */ in.	CHECKED - LP	REVISED -
PLOT DATE = 7/1/2021	DATE - 06/25/2021	REVISED -

**STATE OF ILLINOIS  
DEPARTMENT OF TRANSPORTATION**

<b>SIGN PANEL DESIGN</b>				
SCALE:	SHEET	OF	SHEETS	STA. TO STA.

F.A.I. RTE.	SECTION	COUNTY	TOTAL SHEETS	SHEET NO.
55	2021-128-SG	VARIOUS	178	123
CONTRACT NO. 62P27				
ILLINOIS			FED. AID PROJECT	

**DETAILS**

"TOLL" PLAQUE DETAIL DESIGN

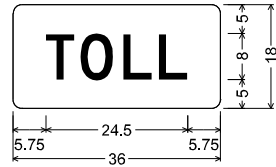

1.50" Radius, 0.00" Border, White on Yellow;

"TOLL" Black, D 2K;

Table of widths and spaces

	<b>T</b>	<b>O</b>	<b>L</b>	<b>L</b>	<b>L</b>	<b>L</b>	<b>L</b>
	4.88	5.63	5.00	1.13	5.00	5.75	5.75

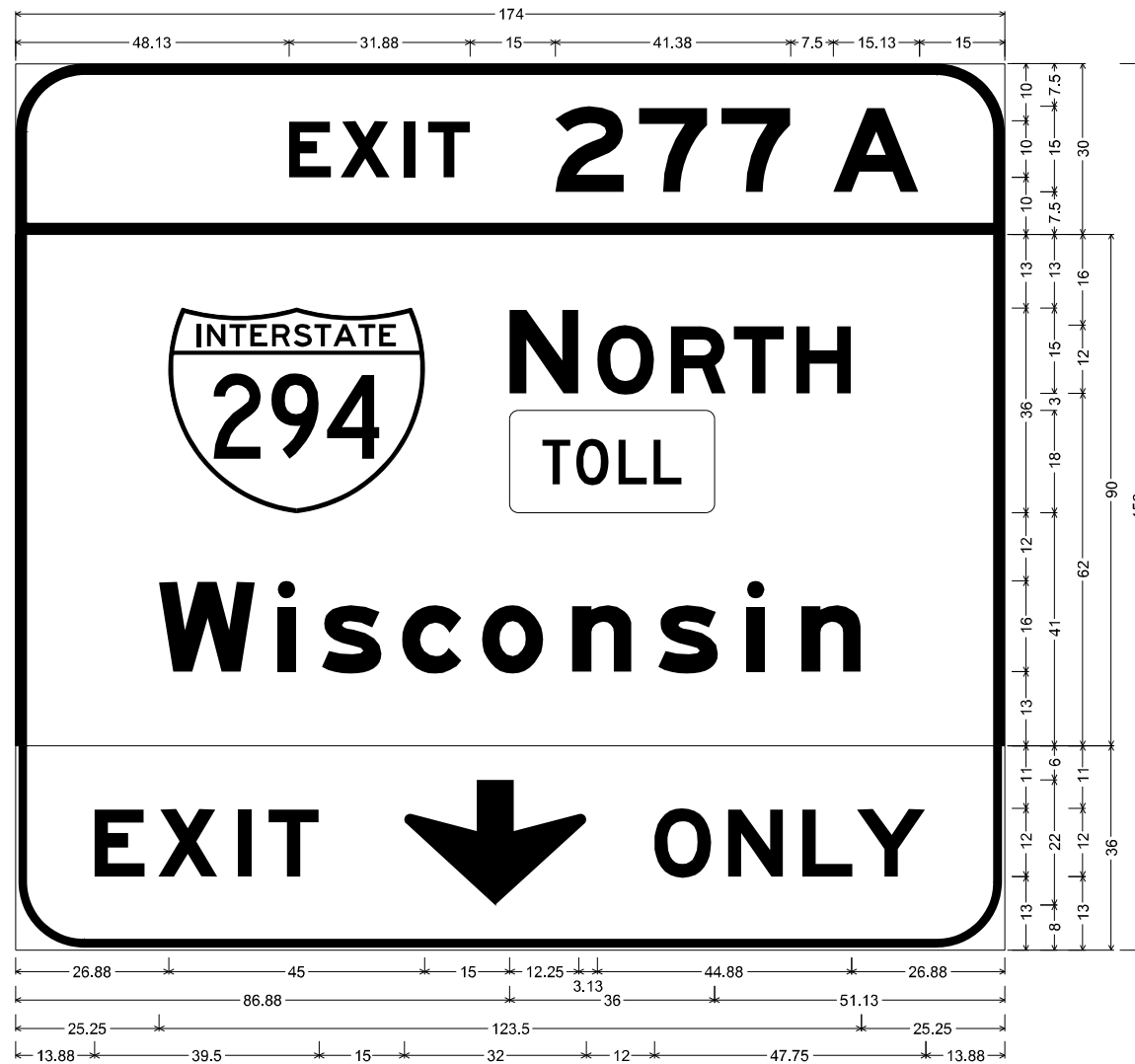

12.00" Radius, 2.00" Border, White on Green;  
 "EXIT", E Mod 2K 120% spacing; "277", E Mod 2K; "A", E Mod 2K;

12.00" Radius, 2.00" Border, White on Green;  
 "NORTH", E Mod 2K; Rounded Rectangle 1.50" Radius Yellow;  
 "Wisconsin", E Mod 2K;

12.00" Radius, 1.50" Border, 0.50" Indent, Black on Yellow;  
 "EXIT", E Mod 2K 140% spacing; Down Arrow 22.00" 270"; "ONLY", E Mod 2K;

Table of widths and spaces

48.13	<b>E</b>	<b>X</b>	<b>I</b>	<b>T</b>	<b>2</b>	<b>7</b>	<b>7</b>	<b>A</b>									
7.38	1.63	8.75	2.50	2.00	2.13	7.38	15.00	12.25	2.50	12.13	2.38	12.25	7.50	15.13	15.00		
26.88	<b>N</b>	<b>O</b>	<b>R</b>	<b>T</b>	<b>H</b>												
45.00	15.00	12.25	3.13	10.13	2.88	9.75	1.25	8.88	2.25	9.63	27.00						
86.88																	
25.25	<b>W</b>	<b>I</b>	<b>S</b>	<b>C</b>	<b>O</b>	<b>N</b>	<b>S</b>	<b>I</b>	<b>N</b>								
17.00	3.75	3.25	4.63	10.50	3.63	10.50	3.50	10.88	5.00	10.50	4.75	10.50	5.00	3.13	6.38	10.63	25.25
13.88	<b>E</b>	<b>X</b>	<b>I</b>	<b>T</b>	<b>O</b>	<b>N</b>	<b>L</b>	<b>Y</b>									
8.88	2.38	10.38	3.50	2.50	3.00	8.88	15.00	32.00	12.00	10.00	2.88	9.75	3.38	8.88	0.75	12.13	13.88

STRUCTURE NUMBER		1C0161055L277.4-000
LOCATION		76 EXPRESSWAY
SIZE (W x H)	EXIT PLAQUE	-
	MAIN PANEL	14.5' X 13'
MOUNTING / TYPE		OVERHEAD / CANTILEVER
MOUNTING LOC (L, M, R)		
SHEETING / COLOR	BACKGROUND	TYPE: ZZ
		COLOR: GREEN
		TYPE:
	LEGEND / BORDER	TYPE: ZZ
		COLOR: WHITE
		TYPE:
	COLOR:	

MODEL: D:\p\p\Design\KKS\Signs Design\Contract-46556-Signs-Structure-Design-155-And-1200-County-4-Enc-84-co-Wiscon-84-CDD\62P27-155\_Signs-IP-KK-COMBRED-06-28-21.dwg

USER NAME = plascencjal	DESIGNED - KK	REVISED -
DRAWN - KK / IP	REVISIONS	
PLOT SCALE = 40,0000 * / in.	CHECKED - LP	REVISED -
PLOT DATE = 7/1/2021	DATE - 06/25/2021	REVISED -

**STATE OF ILLINOIS  
 DEPARTMENT OF TRANSPORTATION**

**SIGN PANEL DESIGN**

SCALE: SHEET OF SHEETS STA. TO STA.

F.A.I. RTE.	SECTION	COUNTY	TOTAL SHEETS	SHEET NO.
55	2021-128-SG	VARIOUS	178	124
CONTRACT NO. 62P27				
ILLINOIS FED. AID PROJECT				



STRUCTURE NUMBER		1S0161055L277.3-000	
LOCATION		77A EXPRESSWAY	
SIZE (W x H)	EXIT PLAQUE	-	
	MAIN PANEL	19' X 8.5'	
MOUNTING / TYPE		OVERHEAD / TRUSS	
MOUNTING LOC (L, M, R)		LEFT	
SHEETING / COLOR	BACKGROUND	TYPE:	ZZ
		COLOR:	GREEN
		TYPE:	
		COLOR:	
	LEGEND / BORDER	TYPE:	ZZ
		COLOR:	WHITE
		TYPE:	
		COLOR:	

STRUCTURE NUMBER		1S0161055L277.3-000	
LOCATION		77B EXPRESSWAY	
SIZE (W x H)	EXIT PLAQUE	-	
	MAIN PANEL	14.5' X 12.5'	
MOUNTING / TYPE		OVERHEAD / TRUSS	
MOUNTING LOC (L, M, R)		RIGHT	
SHEETING / COLOR	BACKGROUND	TYPE:	ZZ
		COLOR:	GREEN
		TYPE:	
		COLOR:	
	LEGEND / BORDER	TYPE:	ZZ
		COLOR:	WHITE
		TYPE:	
		COLOR:	

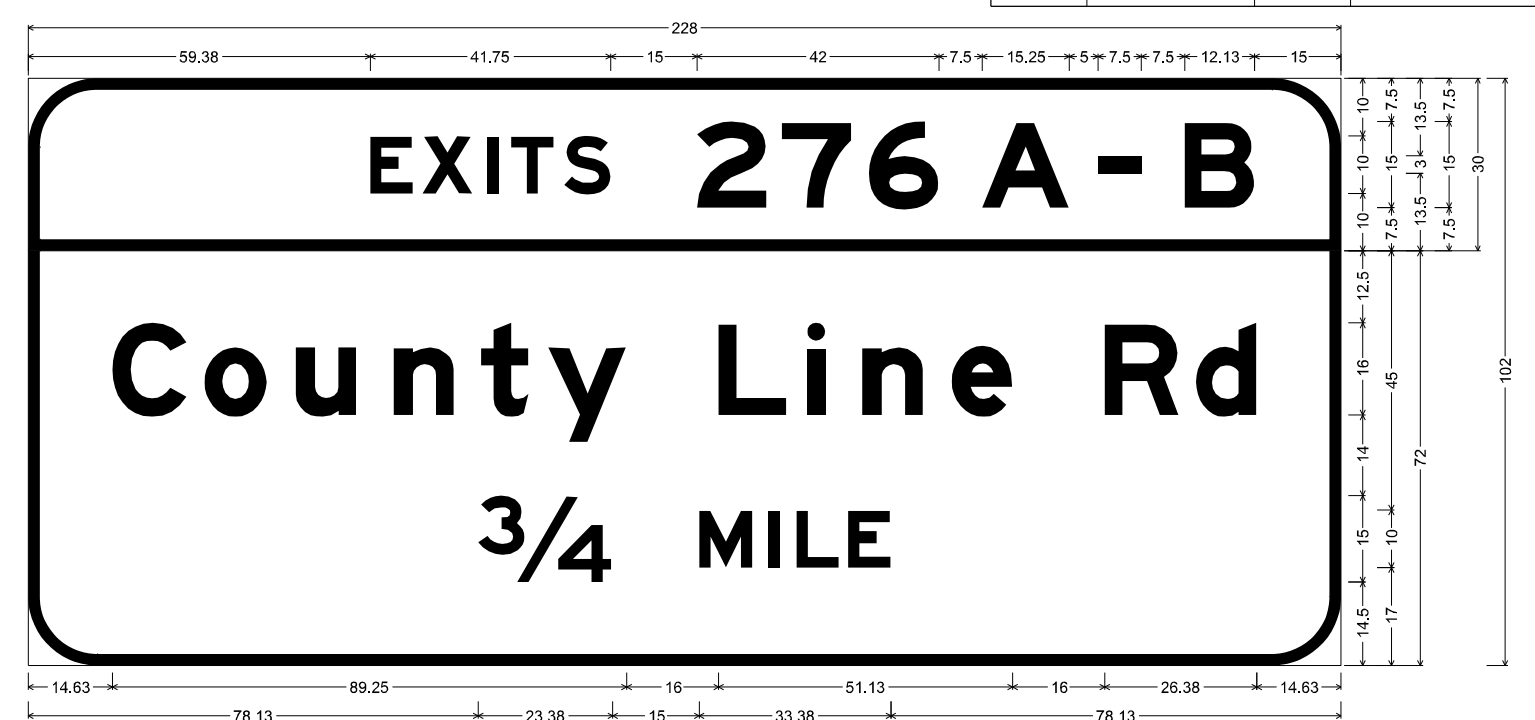

12.00" Radius, 2.00" Border, White on Green;  
"EXITS", E Mod 2K 120% spacing; "276", E Mod 2K; "A", E Mod 2K; "B", E Mod 2K;  
12.00" Radius, 2.00" Border, White on Green;  
"County Line Rd", E Mod 2K; "3/4 MILE", E Mod 2K;  
Table of widths and spaces

59.38	E	7.50	1.63	X	8.75	2.50	I	2.00	2.13	T	7.38	1.75	S	8.13	15.00	2	12.13	2.63	7	12.13	3.00	6	12.13	7.50	A	15.13	5.00	□	7.50	B	12.25	15.00						
14.63	C	13.00	3.00	O	10.88	5.00	U	10.50	6.38	N	10.63	4.63	t	8.25	3.38	y	13.63	16.00	L	11.88	3.50	i	3.25	6.38	n	10.50	5.00	e	10.50	16.00	R	13.00	2.88	d	10.50	14.75		
78.13	3/4	23.38	15.00	M	9.38	2.75	I	2.00	2.75	L	7.50	1.50	E	7.50	78.13																							

### DETAILS

"TOLL" PLAQUE DETAIL DESIGN

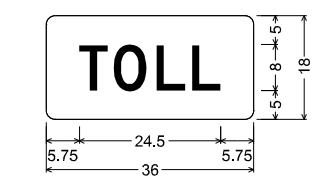

1.50" Radius, 0.00" Border, White on Yellow;  
"TOLL" Black, D 2K;  
Table of widths and spaces

5.75	T	4.88	1.13	□	5.63	L	1.75	L	5.00	1.13	L	5.00	5.75
------	---	------	------	---	------	---	------	---	------	------	---	------	------

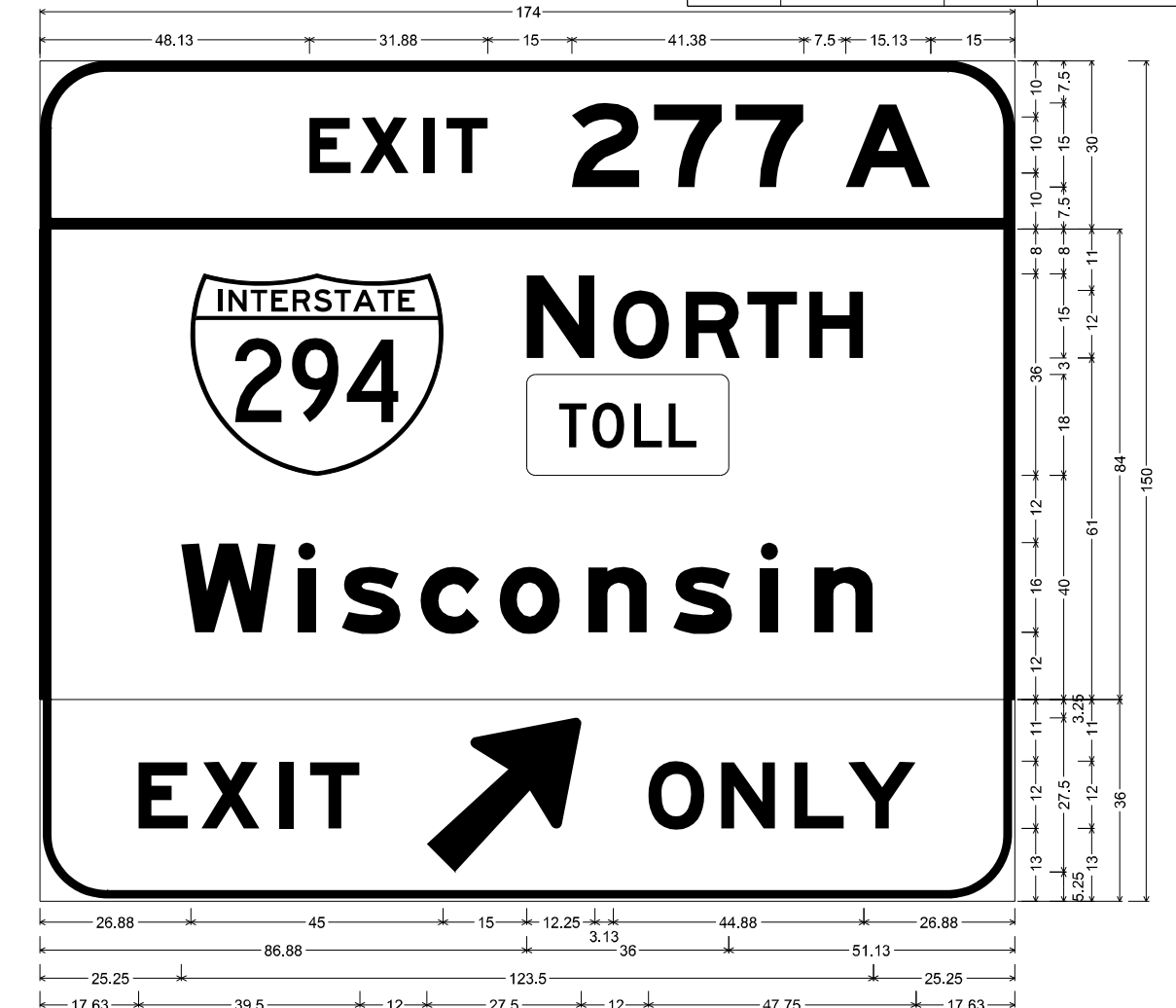

12.00" Radius, 2.00" Border, White on Green;  
"EXIT", E Mod 2K 120% spacing; "277", E Mod 2K; "A", E Mod 2K;  
12.00" Radius, 2.00" Border, White on Green;  
"NORTH", E Mod 2K; Rounded Rectangle 1.50" Radius Yellow;  
"Wisconsin", E Mod 2K;

12.00" Radius, 1.50" Border, 0.50" Indent, Black on Yellow;  
"EXIT", E Mod 2K specified length; Arrow 160 - 35.00" 45°; "ONLY", E Mod 2K specified length;  
Table of widths and spaces

48.13	E	7.38	1.63	X	8.75	2.50	I	2.00	2.13	T	7.38	15.00	2	12.25	2.50	7	12.13	2.38	T	12.25	7.50	A	15.13	15.00			
26.88	□	45.00	15.00	N	12.25	3.13	O	10.13	2.88	R	9.75	1.25	T	8.88	2.25	H	9.63	27.00									
86.88	□	36.00	51.13																								
25.25	W	17.00	3.75	i	3.25	4.63	s	10.50	3.63	c	10.50	3.50	o	10.88	5.00	n	10.50	4.75	s	10.50	5.00	i	3.13	6.38	n	10.63	25.25
17.63	E	8.88	2.38	X	10.38	3.50	I	2.38	3.13	T	8.88	11.88	□	27.63	12.00	O	10.00	2.88	N	9.75	3.38	L	8.88	0.75	Y	12.13	17.50

MODEL: P:\dxf\11... FILE NAME: S:\proj\Design\KKS\Signs\_Design\Contract-485565-Signs\_Structure\Design-155\_and-1290-County+Inc-Racine-Wisconsin-277A-Expressway-1290-County+Inc-Racine-Wisconsin-277A-Expressway-06-28-21.dwg

USER NAME = plascencia	DESIGNED -	KK	REVISED -	
PLOT SCALE = 40,0000 '*/ in.	DRAWN -	KK / IP	REVISED -	
PLOT DATE = 7/1/2021	CHECKED -	LP	REVISED -	
	DATE -	06/25/2021	REVISED -	

**STATE OF ILLINOIS  
DEPARTMENT OF TRANSPORTATION**

SIGN PANEL DESIGN				F.A.I. RTE.	SECTION	COUNTY	TOTAL SHEETS	SHEET NO.				
SCALE:	SHEET	OF	SHEETS	STA.	TO STA.	ILLINOIS	FED. AID PROJECT					
						55	2021-128-SG	VARIOUS	178	125	CONTRACT NO. 62P27	

STRUCTURE NUMBER		1C0161055L276.8-000	
LOCATION		78 EXPRESSWAY	
SIZE (W x H)	EXIT PLAQUE	-	
	MAIN PANEL	19' X 10.5'	
MOUNTING / TYPE		OVERHEAD / CANTILEVER	
MOUNTING LOC (L, M, R)			
SHEETING / COLOR	BACKGROUND	TYPE:	ZZ
		COLOR:	GREEN
		TYPE:	
		COLOR:	
	LEGEND / BORDER	TYPE:	ZZ
		COLOR:	WHITE
		TYPE:	
		COLOR:	

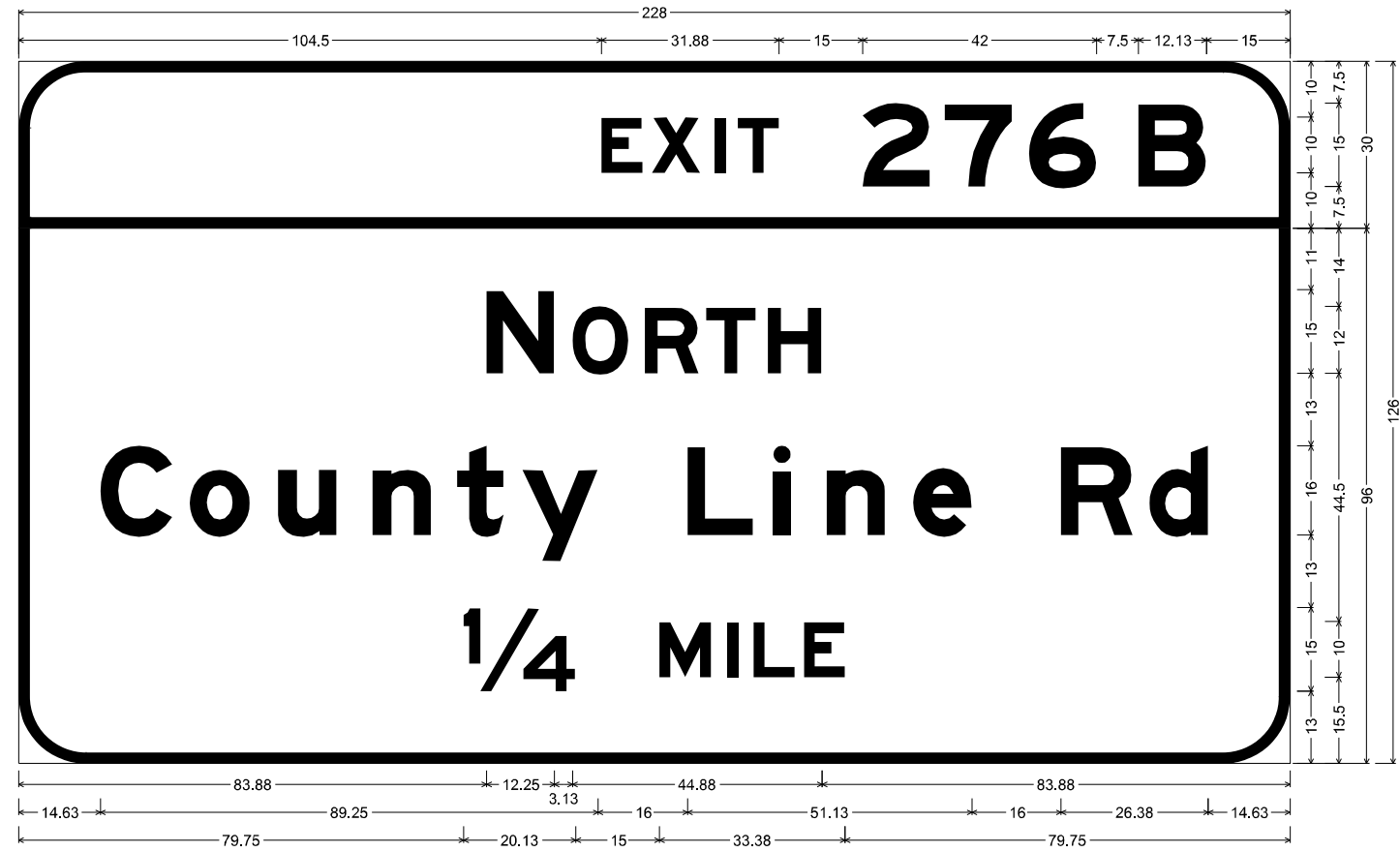

12.00" Radius, 2.00" Border, White on Green;  
 "EXIT", E Mod 2K 120% spacing; "276", E Mod 2K; "B", E Mod 2K;

12.00" Radius, 2.00" Border, White on Green;  
 "NORTH", E Mod 2K; "County Line Rd", E Mod 2K; "1/4 MILE", E Mod 2K;

Table of widths and spaces

104.50	E	7.38	1.75	X	8.63	2.50	I	2.00	2.25	T	7.38	15.00	2	12.13	2.50	7	12.13	3.00	6	12.25	7.50	B	12.13	15.00												
83.88	N	12.25	3.13	O	10.13	2.88	R	9.75	1.25	T	8.88	2.25	H	9.63	84.00																					
14.63	C	13.00	3.00	O	10.88	5.00	U	10.50	6.38	n	10.63	4.63	t	8.25	3.38	y	13.63	16.00	L	11.88	3.50	i	3.25	6.38	n	10.50	5.00	e	10.50	16.00	R	13.00	2.88	d	10.50	14.75
79.75	1/4	20.13	15.00	M	9.38	2.75	I	2.00	2.75	L	7.50	1.50	E	7.50	79.75																					

MODEL: Defalt  
 FILE NAME: S:\IP\Design\KKS\Signs-Design\Contract-48556-Signs-Structure-Design-L55-and-L200-County-Line-Rd-Signs-Structure-Design-L55-and-L200-County-Line-Rd-Signs-Structure-Design-06-28-21.dwg  
 DATE: 7/1/2021

USER NAME	= plascenciaj	DESIGNED -	KK	REVISED -	
DRAWN	- KK / IP	REVISED	-		
PLOT SCALE	= 40,0000 */ in.	CHECKED -	LP	REVISED -	
PLOT DATE	= 7/1/2021	DATE -	06/25/2021	REVISED -	

**STATE OF ILLINOIS**  
**DEPARTMENT OF TRANSPORTATION**

<b>SIGN PANEL DESIGN</b>	
SCALE:	SHEET OF SHEETS STA. TO STA.

F.A.I. RTE.	SECTION	COUNTY	TOTAL SHEETS	SHEET NO.
55	2021-128-SG	VARIOUS	178	126
CONTRACT NO. 62P27				
ILLINOIS FED. AID PROJECT				

STRUCTURE NUMBER		1S0161055L276.5-000	
LOCATION		79A EXPRESSWAY	
SIZE (W x H)	EXIT PLAQUE	-	
	MAIN PANEL	15.5' X 12.5'	
MOUNTING / TYPE		OVERHEAD / TRUSS	
MOUNTING LOC (L, M, R)		LEFT	
SHEETING / COLOR	BACKGROUND	TYPE:	ZZ
		COLOR:	GREEN
		TYPE:	
	LEGEND / BORDER	TYPE:	ZZ
		COLOR:	WHITE
		TYPE:	
	COLOR:		

STRUCTURE NUMBER		1S0161055L276.5-000	
LOCATION		79B EXPRESSWAY	
SIZE (W x H)	EXIT PLAQUE	-	
	MAIN PANEL	19' X 10.5'	
MOUNTING / TYPE		OVERHEAD / TRUSS	
MOUNTING LOC (L, M, R)		MIDDLE	
SHEETING / COLOR	BACKGROUND	TYPE:	ZZ
		COLOR:	GREEN
		TYPE:	
	LEGEND / BORDER	TYPE:	ZZ
		COLOR:	WHITE
		TYPE:	
	COLOR:		

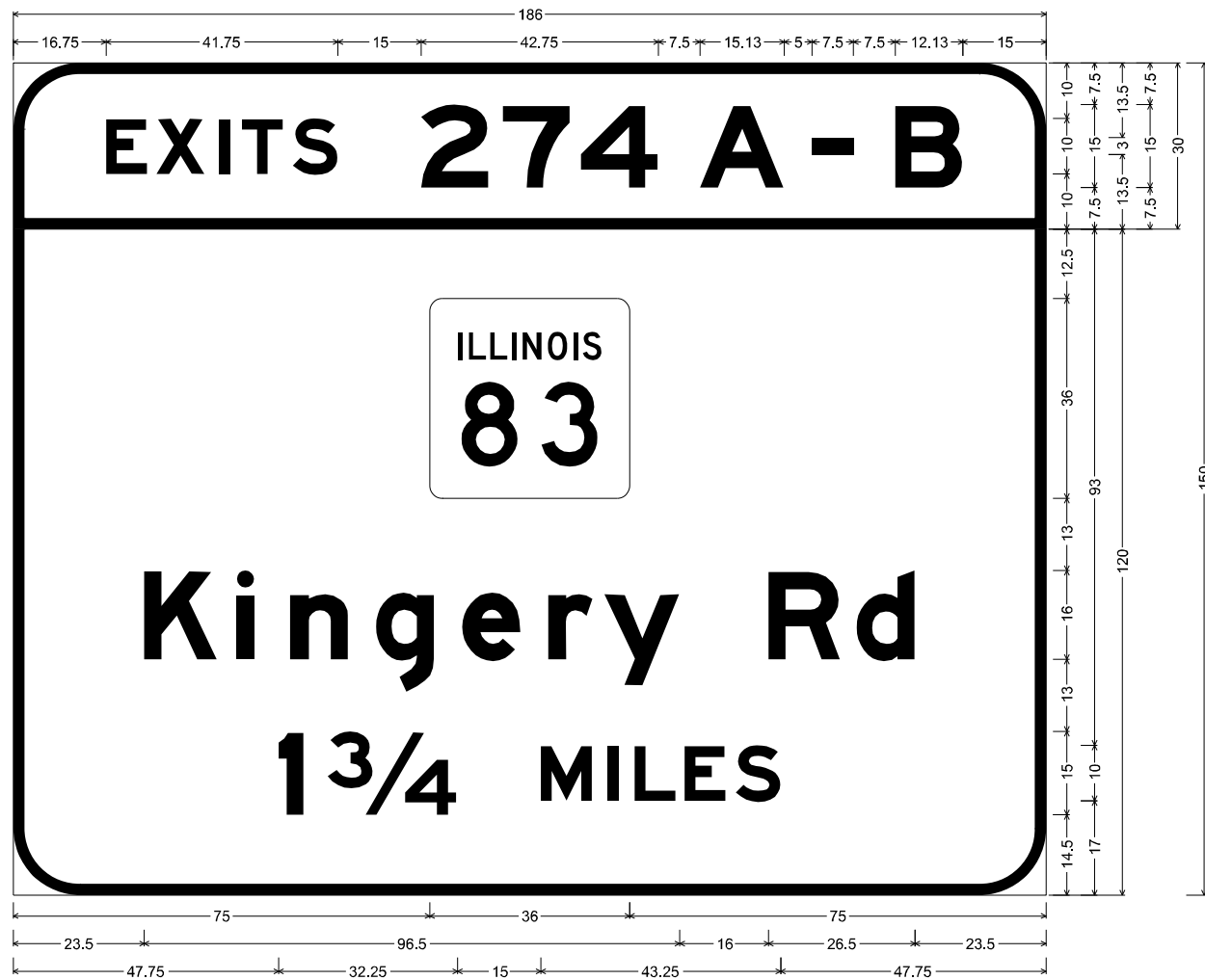

12.00" Radius, 2.00" Border, White on Green;  
 "EXITS", E Mod 2K 120% spacing; "274", E Mod 2K; "A", E Mod 2K; "B", E Mod 2K;

12.00" Radius, 2.00" Border, White on Green;  
 "Kingery Rd", E Mod 2K; "1 3/4 MILES", E Mod 2K;

Table of widths and spaces

16.75	E	7.38	X	1.63	8.75	I	2.50	T	2.00	S	1.88	2	12.25	7	12.13	4	13.88	A	15.25	□	7.50	B	12.13	15.00
75.00		36.00		75.00																				
23.50	K	13.13	i	3.63	n	10.63	g	10.63	e	10.63	r	8.00	2.00	y	13.63	R	13.00	d	10.50	23.63				
47.75	l	4.50	3/4	23.38	M	9.25	I	2.00	L	7.38	E	1.63	1.88	S	8.00	47.88								

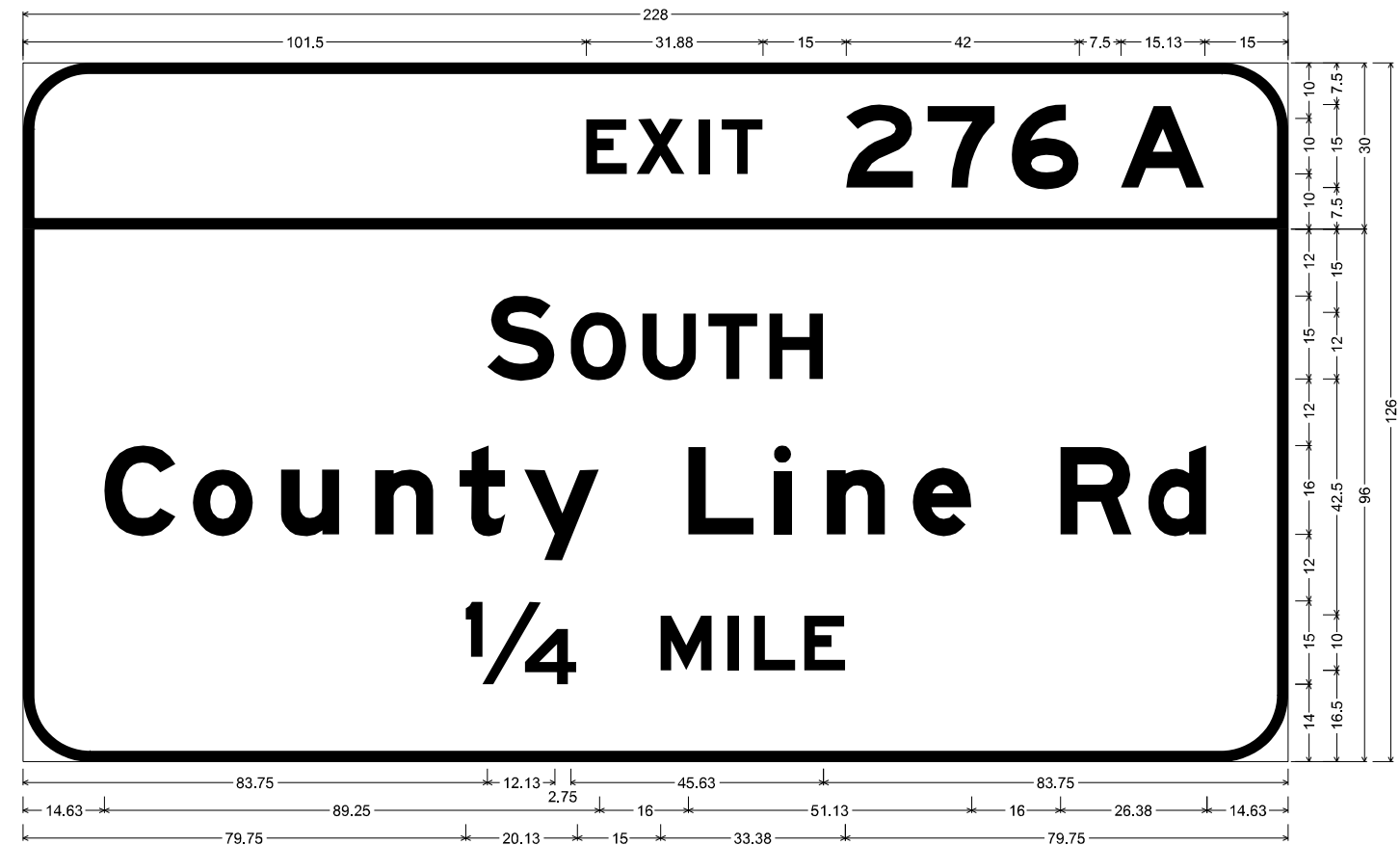

12.00" Radius, 2.00" Border, White on Green;

"EXIT", E Mod 2K 120% spacing; "276", E Mod 2K; "A", E Mod 2K;

12.00" Radius, 2.00" Border, White on Green;

"SOUTH", E Mod 2K; "County Line Rd", E Mod 2K; "1/4 MILE", E Mod 2K;

Table of widths and spaces

101.50	E	7.38	X	1.75	8.63	I	2.50	T	2.25	2	15.00	7	12.13	6	12.25	A	15.13	15.00										
83.75	S	12.13	O	2.75	10.13	U	2.88	T	2.13	H	9.75	83.75																
14.63	C	13.00	o	10.88	u	10.50	n	10.63	t	8.25	3.38	y	13.63	L	11.88	i	3.25	6.38	n	10.50	e	10.50	16.00	R	13.00	d	10.50	14.75
79.75	1/4	20.13	M	9.38	I	2.00	L	7.50	1.50	E	7.50	79.75																

MODEL: D:\p\p\Design\KKS\Signs - Design\Contract-46556-Signs-Structure-Design-155-And-1200-County-4-Line-Road-4-Water-Road-CDD\62P27-155\_Signs-IP-KK-CO\BIBED-06-28-21.com

USER NAME = plascncial	DESIGNED - KK	REVISED -
DRAWN - KK / IP	REVISED -	
PLOT SCALE = 40,0000 * / in.	CHECKED - LP	REVISED -
PLOT DATE = 7/1/2021	DATE - 06/25/2021	REVISED -

STATE OF ILLINOIS  
DEPARTMENT OF TRANSPORTATION

SIGN PANEL DESIGN

SCALE: SHEET OF SHEETS STA. TO STA.

F.A.I. RTE.	SECTION	COUNTY	TOTAL SHEETS	SHEET NO.
55	2021-128-SG	VARIOUS	178	127
CONTRACT NO. 62P27				
ILLINOIS FED. AID PROJECT				

STRUCTURE NUMBER		IS016I055L276.5-000	
LOCATION		79C	EXPRESSWAY
SIZE (W x H)	EXIT PLAQUE	-	
	MAIN PANEL	19' X 11.5'	
MOUNTING / TYPE		OVERHEAD / TRUSS	
MOUNTING LOC (L, M, R)		RIGHT	
SHEETING / COLOR	BACKGROUND	TYPE:	ZZ
		COLOR:	GREEN
		TYPE:	
	LEGEND / BORDER	COLOR:	
		TYPE:	ZZ
		COLOR:	WHITE

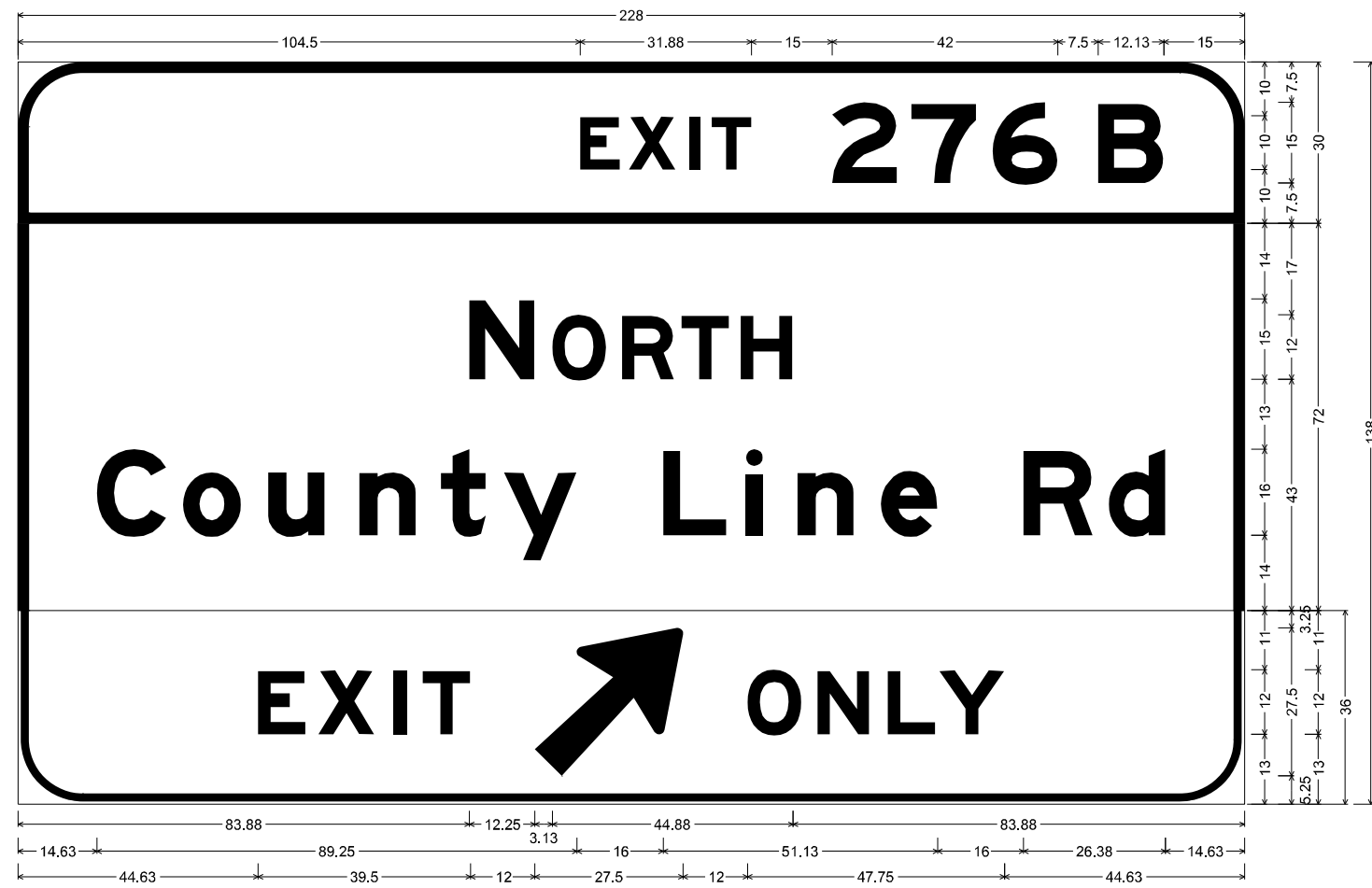

12.00" Radius, 2.00" Border, White on Green;  
 "EXIT", E Mod 2K 120% spacing; "276", E Mod 2K; "B", E Mod 2K;

12.00" Radius, 2.00" Border, White on Green;  
 "NORTH", E Mod 2K; "County Line Rd", E Mod 2K;

12.00" Radius, 1.50" Border, 0.50" Indent, Black on Yellow;  
 "EXIT", E Mod 2K specified length; Arrow 160 - 35.00" 45"; "ONLY", E Mod 2K specified length;

Table of widths and spaces

104.50	E	7.38	1.75	X	8.63	2.50	I	2.00	2.25	T	7.38	15.00	Z	12.13	2.50	7	12.13	3.00	6	12.25	7.50	B	12.13	15.00											
83.88	N	12.25	3.13	O	10.13	2.88	R	9.75	1.25	T	8.88	2.25	H	9.63	84.00																				
14.63	C	13.00	3.00	O	10.88	5.00	U	10.50	6.38	N	10.63	4.63	T	8.25	3.38	Y	13.63	16.00	L	11.88	3.50	I	6.38	N	10.50	5.00	E	10.50	16.00	R	13.00	2.88	D	10.50	14.75
44.63	E	8.88	2.38	X	10.38	3.50	I	2.38	3.13	T	8.88	11.88	↗	27.63	12.00	O	10.00	2.88	N	9.75	3.38	L	8.88	0.75	Y	12.13	44.50								

MODEL: D:\p\h\...  
 FILE NAME: S:\IP\Design\KKS\Signs\_Design\Contract-48556-Signs\_Structure\Design-455-and-4290-County-Line-Rd-co-Water-Rd\CDD\62P27155\_Signs-IP-KK-COMBRED-06-28-21.dwg

USER NAME = plascencjal	DESIGNED - KK	REVISED -
DRAWN - KK / IP	REVISED -	
PLOT SCALE = 40,0000 * / in.	CHECKED - LP	REVISED -
PLOT DATE = 7/1/2021	DATE - 06/25/2021	REVISED -

**STATE OF ILLINOIS**  
**DEPARTMENT OF TRANSPORTATION**

<b>SIGN PANEL DESIGN</b>			
SCALE:	SHEET	OF	SHEETS
	STA.		TO STA.

F.A.I. RTE.	SECTION	COUNTY	TOTAL SHEETS	SHEET NO.
55	2021-128-SG	VARIOUS	178	128
CONTRACT NO. 62P27				
ILLINOIS FED. AID PROJECT				

STRUCTURE NUMBER		1S022I055L274.9-000
LOCATION		80A EXPRESSWAY
SIZE (W x H)	EXIT PLAQUE	-
	MAIN PANEL	15.5' X 8.5'
MOUNTING / TYPE		OVERHEAD / TRUSS
MOUNTING LOC (L, M, R)		LEFT
SHEETING / COLOR	BACKGROUND	TYPE: ZZ
		COLOR: GREEN
		TYPE:
		COLOR:
	LEGEND / BORDER	TYPE: ZZ
		COLOR: WHITE
		TYPE:
		COLOR:

STRUCTURE NUMBER		1S022I055L274.9-000
LOCATION		80B EXPRESSWAY
SIZE (W x H)	EXIT PLAQUE	-
	MAIN PANEL	18' X 10.5'
MOUNTING / TYPE		OVERHEAD / TRUSS
MOUNTING LOC (L, M, R)		RIGHT
SHEETING / COLOR	BACKGROUND	TYPE: ZZ
		COLOR: GREEN
		TYPE:
		COLOR:
	LEGEND / BORDER	TYPE: ZZ
		COLOR: WHITE
		TYPE:
		COLOR:

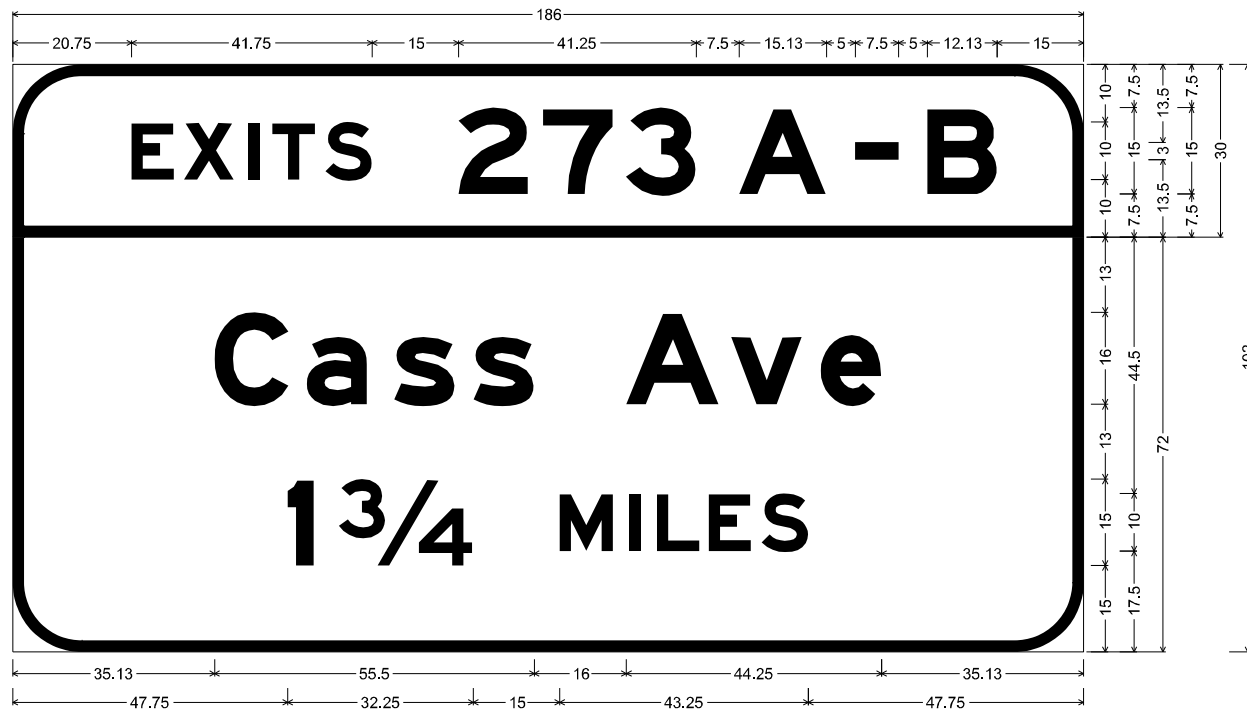

12.00" Radius, 2.00" Border, White on Green;  
 "EXITS", E Mod 2K 120% spacing; "273", E Mod 2K; "A", E Mod 2K; "B", E Mod 2K;

12.00" Radius, 2.00" Border, White on Green;  
 "Cass Ave", E Mod 2K; "1 3/4 MILES", E Mod 2K;  
 Table of widths and spaces

20.75	E	7.38	1.63	X	8.75	2.50	I	2.00	2.13	T	7.38	1.88	S	8.00	15.00	Z	12.25	2.50	7	12.13	2.25	3	12.13	7.50	A	15.25	5.00	□	7.50	5.00	B	12.13	15.00
35.13	C	12.88	3.13	a	10.50	4.63	s	10.63	3.13	s	10.63	16.00	A	16.13	2.00	v	12.38	3.25	e	10.50	35.13												
47.75	I	4.50	4.38	3/4	23.38	15.00	M	9.25	2.88	I	2.00	2.75	L	7.38	1.63	E	7.38	1.88	S	8.00	47.88												

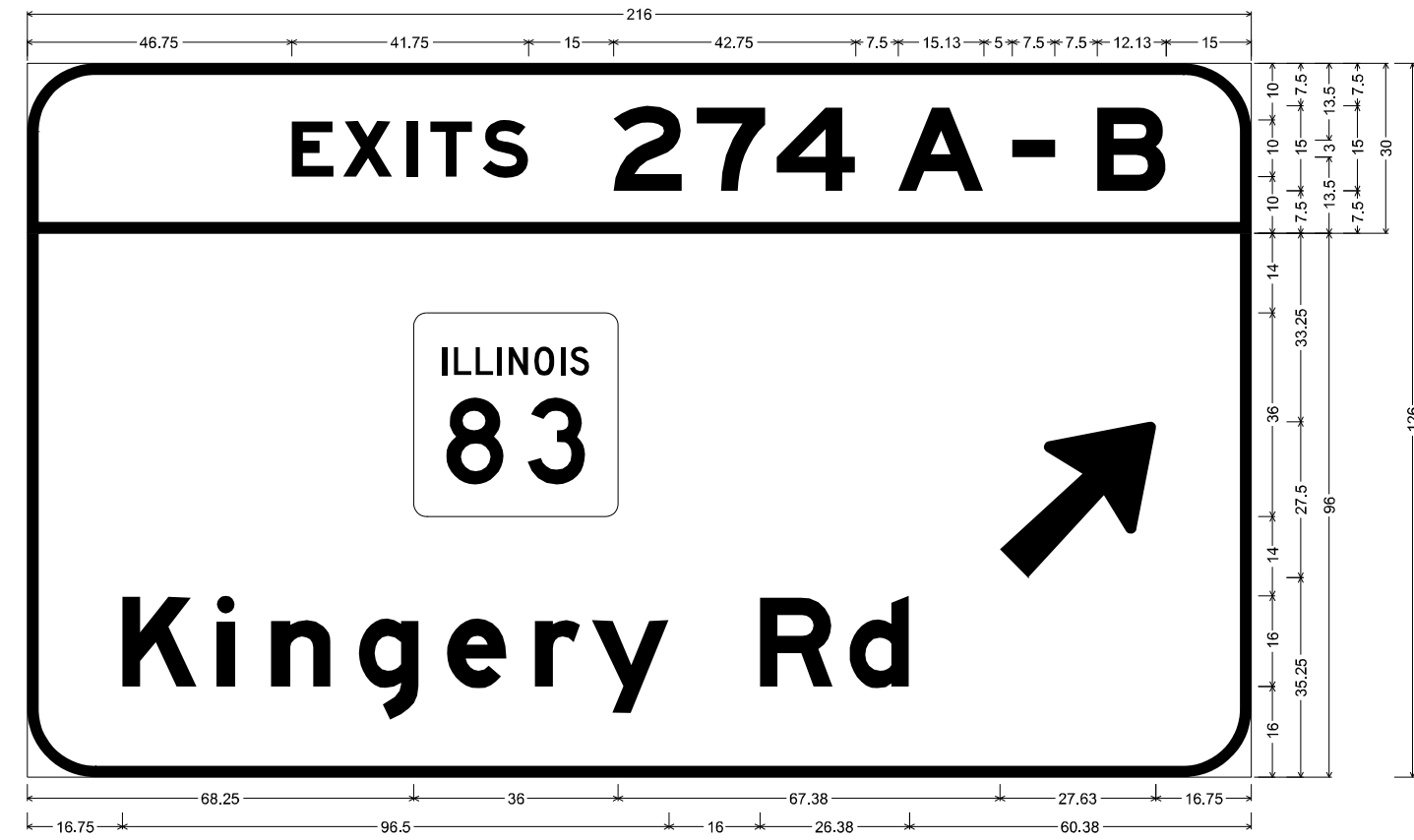

12.00" Radius, 2.00" Border, White on Green;  
 "EXITS", E Mod 2K 120% spacing; "274", E Mod 2K; "A", E Mod 2K; "B", E Mod 2K;

12.00" Radius, 2.00" Border, White on Green;  
 "Kingery Rd", E Mod 2K; Arrow 160 - 35.00" 45";  
 Table of widths and spaces

46.75	E	7.38	1.63	X	8.75	2.50	I	2.00	2.13	T	7.38	1.88	S	8.00	15.00	Z	12.25	2.50	7	12.13	2.00	4	13.88	7.50	A	15.25	5.00	□	7.50	7.50	B	12.13	15.00
68.25	□	36.00	67.38	27.63	16.75																												
16.75	K	13.13	3.50	i	3.25	6.38	n	10.63	4.88	g	10.63	4.88	e	10.63	5.00	r	8.00	2.00	y	13.63	16.00	R	13.00	2.88	d	10.50	60.38						

MODEL: D:\p\p\...  
 FILE NAME: S:\IP\Design\KKS\Signs\_Design\Contract-48556-Signs\_Structure-Design-155-And-1200-County-4-Enc-Rd-4-Webster-Rd\CADD\62P274.95\_Signs-IP-KK-CO\BIBED-06-28-21.dwg

USER NAME = plascenciaj	DESIGNED - KK	REVISED -
DRAWN - KK / IP	REVISIONS -	
PLOT SCALE = 40,0000 * / in.	CHECKED - LP	REVISED -
PLOT DATE = 7/1/2021	DATE - 06/25/2021	REVISED -

**STATE OF ILLINOIS  
DEPARTMENT OF TRANSPORTATION**

**SIGN PANEL DESIGN**

SCALE: SHEET OF SHEETS STA. TO STA.

F.A.I. RTE.	SECTION	COUNTY	TOTAL SHEETS	SHEET NO.
55	2021-128-SG	VARIOUS	178	129
CONTRACT NO. 62P27				
ILLINOIS FED. AID PROJECT				

STRUCTURE NUMBER		1S0221055L274.5-000	
LOCATION		81A	EXPRESSWAY
SIZE (W x H)	EXIT PLAQUE	-	
	MAIN PANEL	10.5' X 9.5'	
MOUNTING / TYPE		OVERHEAD / TRUSS	
MOUNTING LOC (L, M, R)		LEFT	
SHEETING / COLOR	BACKGROUND	TYPE:	ZZ
		COLOR:	GREEN
		TYPE:	
	LEGEND / BORDER	TYPE:	ZZ
		COLOR:	WHITE
		TYPE:	

STRUCTURE NUMBER		1S0221055L274.5-000	
LOCATION		81B	EXPRESSWAY
SIZE (W x H)	EXIT PLAQUE	-	
	MAIN PANEL	13.5' X 7.5'	
MOUNTING / TYPE		OVERHEAD / TRUSS	
MOUNTING LOC (L, M, R)		RIGHT	
SHEETING / COLOR	BACKGROUND	TYPE:	ZZ
		COLOR:	GREEN
		TYPE:	
	LEGEND / BORDER	TYPE:	ZZ
		COLOR:	WHITE
		TYPE:	



12.00" Radius, 2.00" Border, White on Green;  
 "NORTH", E Mod 2K; "Chicago", E Mod 2K; "1/4 MILE", E Mod 2K;  
 Table of widths and spaces

14.13	36.00	12.00	N	9.75	2.63	O	8.38	2.50	R	8.00	1.13	T	7.38	1.88	H	8.00	14.25				
21.88	C	10.88	3.75	h	8.75	5.38	i	2.63	4.13	c	8.75	3.00	a	8.75	4.13	g	8.88	4.13	o	9.00	22.00
28.75	1/4	20.13	15.00	M	9.38	2.75	I	2.00	2.75	L	7.50	1.50	E	7.50	28.75						

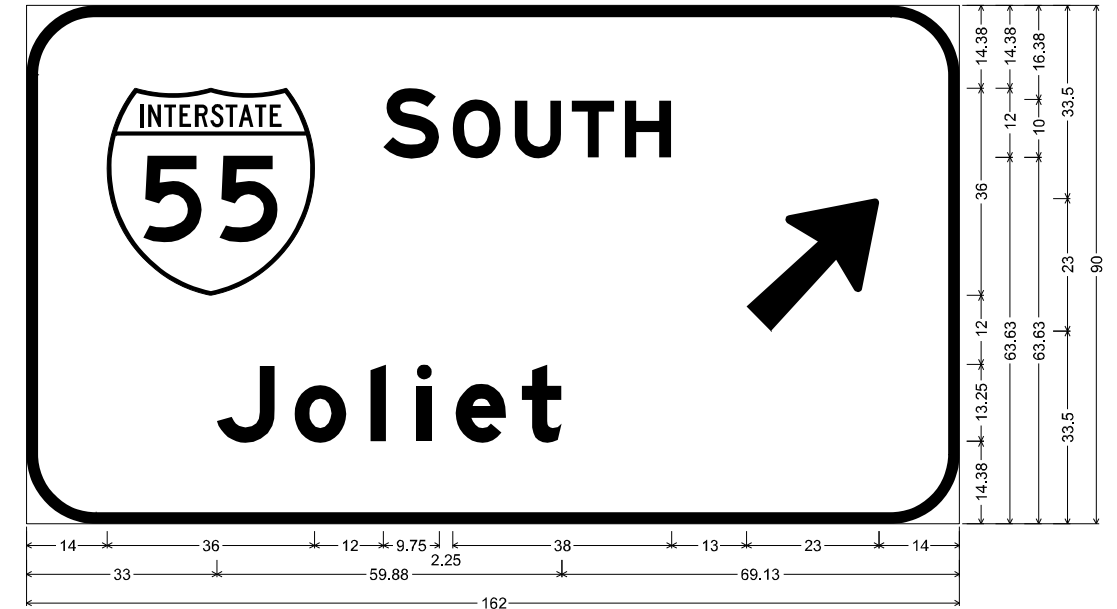

12.00" Radius, 2.00" Border, White on Green;  
 "SOUTH", E Mod 2K; "Joliet", E Mod 2K; Arrow Custom - 29.25" 45";  
 Table of widths and spaces

14.00	36.00	12.00	S	9.75	2.25	O	8.38	2.38	U	8.13	1.88	T	7.38	1.75	H	8.13	13.00	23.00	14.00		
33.00	J	10.25	3.25	o	9.13	4.13	i	2.63	5.38	i	2.63	4.13	e	8.75	2.75	t	6.88	69.13			

MODEL: D:\p\h\...  
 FILE NAME: S:\IP\Design\KKS\Signs\_Design\Contract-46556-Signs-Structure-Design-155\_and-1200-County-4-Enc-84-co-Water-Rd\CADD\62P27455\_Signs\IP-KK-CO\BIBED-06-28-21.dwg

USER NAME =	plascencjal	DESIGNED -	KK	REVISED -	
DRAWN -	KK / IP	REVISIONS -		REVISED -	
PLOT SCALE =	40,0000 * / in.	CHECKED -	LP	REVISED -	
PLOT DATE =	7/1/2021	DATE -	06/25/2021	REVISED -	

STATE OF ILLINOIS  
 DEPARTMENT OF TRANSPORTATION

SIGN PANEL DESIGN

SCALE: SHEET OF SHEETS STA. TO STA.

F.A.I. RTE.	SECTION	COUNTY	TOTAL SHEETS	SHEET NO.
55	2021-128-SG	VARIOUS	178	130
CONTRACT NO. 62P27				
ILLINOIS FED. AID PROJECT				

STRUCTURE NUMBER		1C022I055L274.6-000	
LOCATION		84 EXPRESSWAY	
SIZE (W x H)	EXIT PLAQUE	-	
	MAIN PANEL	18' X 10.5'	
MOUNTING / TYPE		OVERHEAD / CANTILEVER	
MOUNTING LOC (L, M, R)			
SHEETING / COLOR	BACKGROUND	TYPE:	ZZ
		COLOR:	GREEN
		TYPE:	
	LEGEND / BORDER	COLOR:	
		TYPE:	ZZ
		COLOR:	WHITE

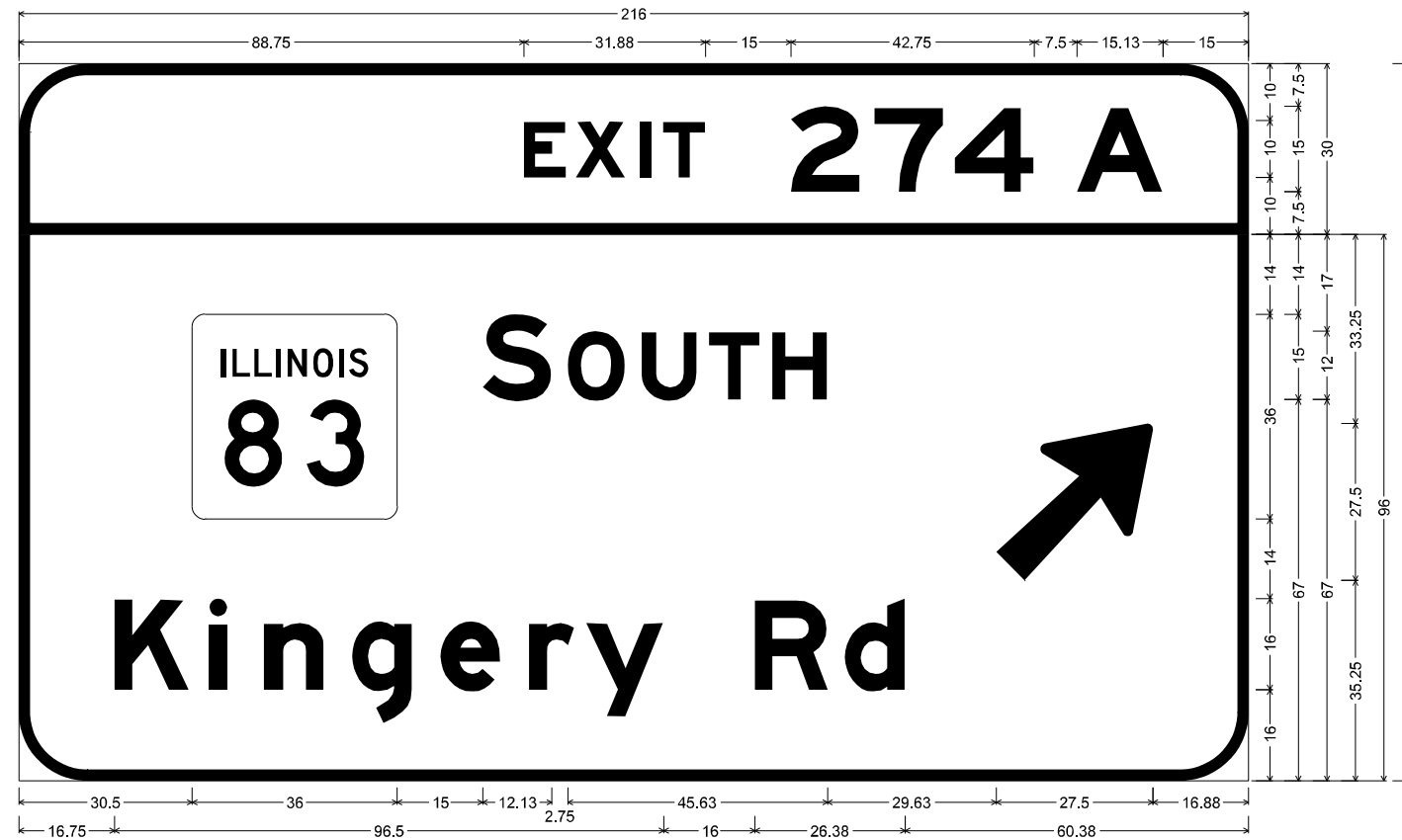

12.00" Radius, 2.00" Border, White on Green;  
 "EXIT", E Mod 2K 120% spacing; "274", E Mod 2K; "A", E Mod 2K;

12.00" Radius, 2.00" Border, White on Green;  
 "SOUTH", E Mod 2K; "Kingery Rd", E Mod 2K; Arrow 160 - 35.00" 45";

Table of widths and spaces

88.75	E	7.38	1.75	X	8.63	2.50	I	2.00	2.25	T	7.38	15.00	Z	12.13	2.50	7	12.13	2.00	4	14.00	7.50	A	15.13	15.00			
30.50		36.00	15.00	S	12.13	2.75	O	10.13	2.88	U	9.75	2.13	T	8.88	2.13	H	9.75	29.63		27.50	16.88						
16.75	K	13.13	3.50	i	3.25	6.38	n	10.63	4.88	g	10.63	4.88	e	10.63	5.00	r	8.00	2.00	y	13.63	16.00	R	13.00	2.88	d	10.50	60.38

MODEL: D:\p\p\Design\KKS\Signs Design\Contract-46556-Signs-Structure-Design-155-and-1200-County-4-Enc-84-co-Water-Rd\CADD\62P27-155\_Signs-IP-KK-COM\BRED-06-28-21.dwg  
 FILE NAME: SignIP\Design\KKS\Signs Design\Contract-46556-Signs-Structure-Design-155-and-1200-County-4-Enc-84-co-Water-Rd\CADD\62P27-155\_Signs-IP-KK-COM\BRED-06-28-21.dwg

USER NAME = plascencjal	DESIGNED - KK	REVISED -
DRAWN - KK / IP	REVISIONS -	
PLOT SCALE = 40,0000 * / in.	CHECKED - LP	REVISED -
PLOT DATE = 7/1/2021	DATE - 06/25/2021	REVISED -

**STATE OF ILLINOIS  
DEPARTMENT OF TRANSPORTATION**

**SIGN PANEL DESIGN**

SCALE: SHEET OF SHEETS STA. TO STA.

F.A.I. RTE.	SECTION	COUNTY	TOTAL SHEETS	SHEET NO.
55	2021-128-SG	VARIOUS	178	131
CONTRACT NO. 62P27			ILLINOIS FED. AID PROJECT	

STRUCTURE NUMBER		1S0221055L273. 2-000	
LOCATION		85A	EXPRESSWAY
SIZE (W x H)	EXIT PLAQUE	-	
	MAIN PANEL	15.5' X 8.5'	
MOUNTING / TYPE		OVERHEAD / TRUSS	
MOUNTING LOC (L, M, R)		LEFT	
SHEETING / COLOR	BACKGROUND	TYPE:	ZZ
		COLOR:	GREEN
		TYPE:	
	LEGEND / BORDER	TYPE:	ZZ
		COLOR:	WHITE
		TYPE:	

STRUCTURE NUMBER		1S0221055L273. 2-000	
LOCATION		85B	EXPRESSWAY
SIZE (W x H)	EXIT PLAQUE	-	
	MAIN PANEL	13' X 10.5'	
MOUNTING / TYPE		OVERHEAD / TRUSS	
MOUNTING LOC (L, M, R)		MIDDLE	
SHEETING / COLOR	BACKGROUND	TYPE:	ZZ
		COLOR:	GREEN
		TYPE:	
	LEGEND / BORDER	TYPE:	ZZ
		COLOR:	WHITE
		TYPE:	

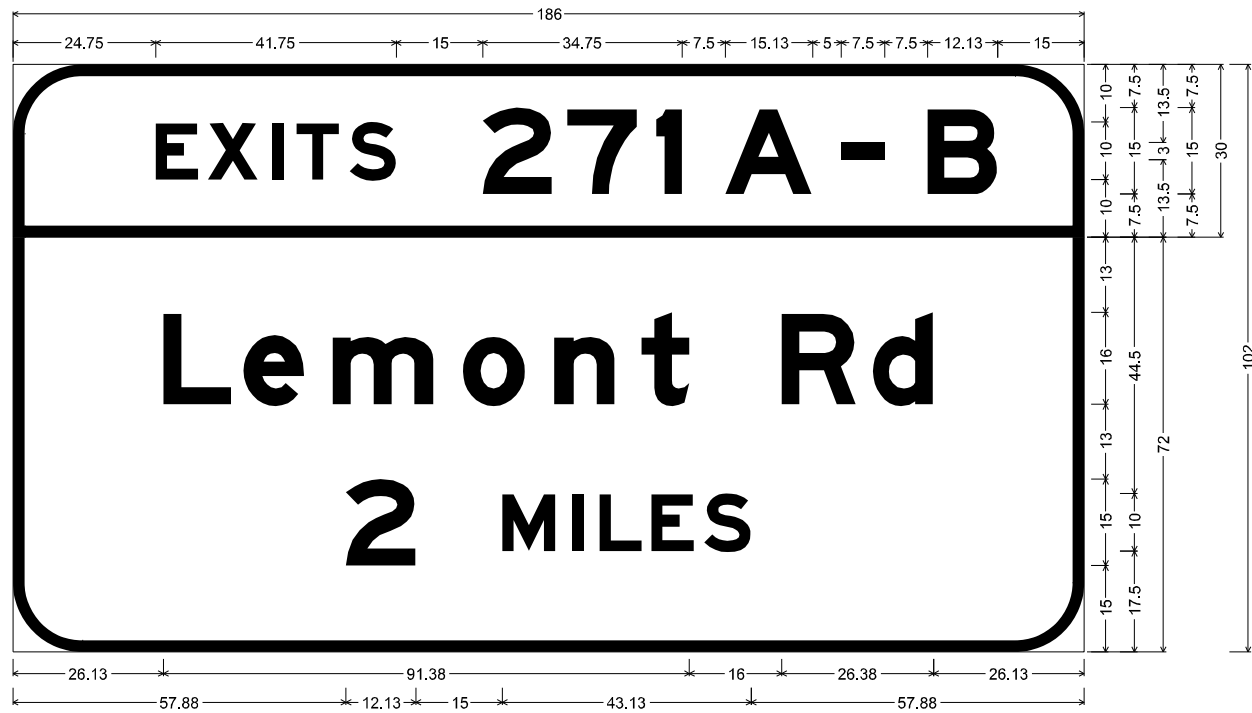

12.00" Radius, 2.00" Border, White on Green;  
 "EXITS", E Mod 2K 120% spacing; "271", E Mod 2K; "A", E Mod 2K; "B", E Mod 2K;

12.00" Radius, 2.00" Border, White on Green;  
 "Lemont Rd", E Mod 2K; "2 MILES", E Mod 2K;  
 Table of widths and spaces

24.75	E	7.50	1.63	X	8.75	2.50	I	2.00	2.13	T	7.38	1.75	S	8.13	15.00	Z	12.13	2.63	7	12.13	3.25	I	4.50	7.50	A	15.25	5.00	□	7.50	7.50	B	12.13	15.00	
26.13	L	11.88	2.00	e	10.63	4.88	m	17.63	5.00	o	10.88	4.88	n	10.63	4.63	t	8.25	16.00	R	13.00	2.88	d	10.63	26.13										
57.88	Z	12.13	15.00	M	9.25	2.88	I	1.88	2.88	L	7.38	1.63	E	7.38	1.75	S	8.13	57.88																

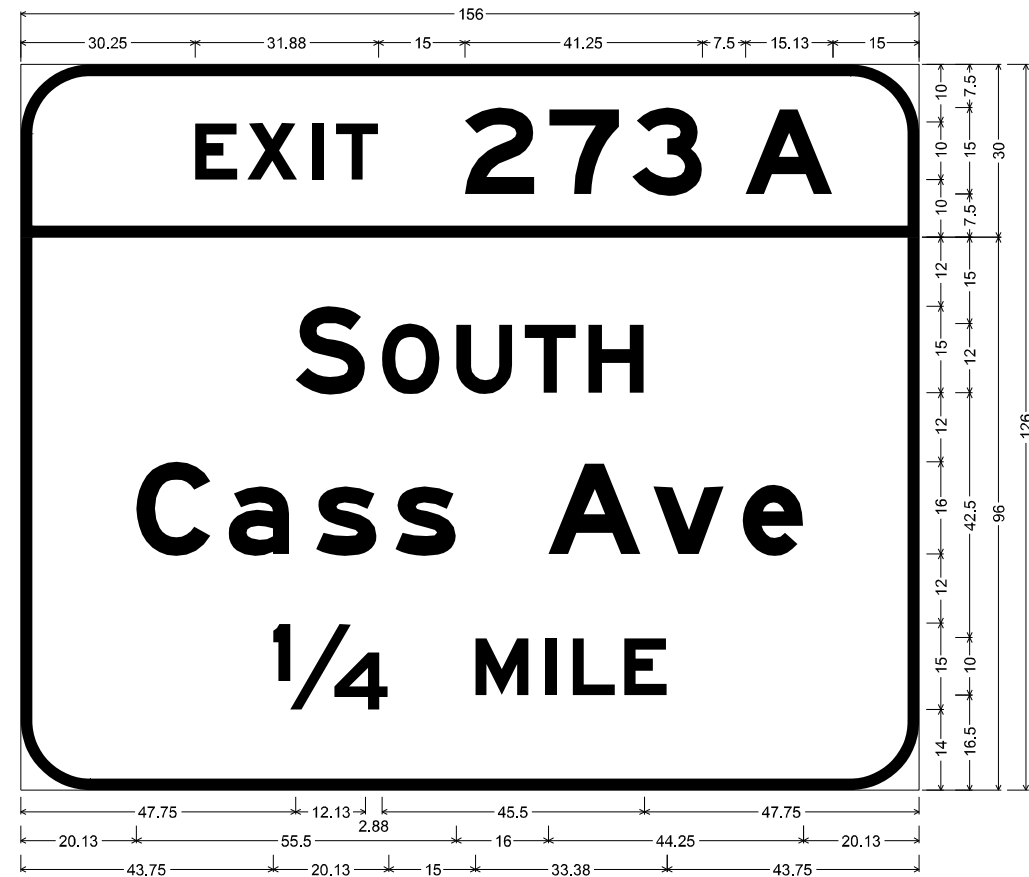

12.00" Radius, 2.00" Border, White on Green;  
 "EXIT", E Mod 2K 120% spacing; "273", E Mod 2K; "A", E Mod 2K;

12.00" Radius, 2.00" Border, White on Green;  
 "SOUTH", E Mod 2K; "Cass Ave", E Mod 2K; "1/4 MILE", E Mod 2K;  
 Table of widths and spaces

30.25	E	7.38	1.75	X	8.63	2.50	I	2.00	2.25	T	7.38	15.00	Z	12.13	2.50	7	12.13	2.25	3	12.25	7.50	A	15.13	15.00
47.75	S	12.13	2.88	O	10.00	2.88	U	9.75	2.13	T	8.88	2.13	H	9.75	47.75									
20.13	C	12.88	3.13	a	10.50	4.63	s	10.63	3.13	s	10.63	16.00	A	16.13	2.00	v	12.38	3.25	e	10.50	20.13			
43.75	1/4	20.13	15.00	M	9.38	2.75	I	2.00	2.75	L	7.50	1.50	E	7.50	43.75									

MODEL: D:\p\p\Design\KKS\Signs - Design\Contract-48556-Signs-Structure-Design-155-and-1200-County-4-Enc-84-cc-Webster-Rd\CADD\62P27155\_Signs\Color-KK-CO\BIBRED-06-28-21.com  
 FILE NAME: S:\P\Design\KKS\Signs - Design\Contract-48556-Signs-Structure-Design-155-and-1200-County-4-Enc-84-cc-Webster-Rd\CADD\62P27155\_Signs\Color-KK-CO\BIBRED-06-28-21.com

USER NAME = plascenciaj	DESIGNED - KK	REVISED -
DRAWN - KK / IP	REVISIONS -	
PLOT SCALE = 40,0000 * / in.	CHECKED - LP	REVISED -
PLOT DATE = 7/1/2021	DATE - 06/25/2021	REVISED -

**STATE OF ILLINOIS**  
**DEPARTMENT OF TRANSPORTATION**

<b>SIGN PANEL DESIGN</b>			
SCALE:	SHEET	OF	SHEETS
	STA.		TO STA.

F.A.I. RTE.	SECTION	COUNTY	TOTAL SHEETS	SHEET NO.
55	2021-128-SG	VARIOUS	178	132
CONTRACT NO. 62P27				
ILLINOIS FED. AID PROJECT				



STRUCTURE NUMBER		1S022I055L273.2-000	
LOCATION		85C EXPRESSWAY	
SIZE (W x H)	EXIT PLAQUE	-	
	MAIN PANEL	16' X 8.5'	
MOUNTING / TYPE		OVERHEAD / TRUSS	
MOUNTING LOC (L, M, R)		RIGHT	
SHEETING / COLOR	BACKGROUND	TYPE:	ZZ
		COLOR:	GREEN
		TYPE:	
	LEGEND / BORDER	COLOR:	
		TYPE:	ZZ
		COLOR:	WHITE



12.00" Radius, 2.00" Border, White on Green;  
 "EXIT", E Mod 2K 120% spacing; "273", E Mod 2K; "B", E Mod 2K;  
 12.00" Radius, 2.00" Border, White on Green;  
 "NORTH", E Mod 2K; "Cass Ave", E Mod 2K; Arrow 160 - 35.00" 45°;  
 Table of widths and spaces

69.25	E	7.38	X	1.75	8.63	2.50	I	2.00	2.25	T	7.38	15.00	2	12.13	2.50	7	12.13	2.25	3	12.25	7.50	B	12.13	15.00
44.13	N	12.13	O	3.25	10.13	2.88	R	9.75	1.25	T	8.88	2.25	H	9.63	43.88	27.50	16.38							
16.38	C	12.88	a	3.00	10.63	4.63	s	10.50	3.25	s	10.63	16.00	A	16.13	2.00	v	12.38	3.25	e	10.50	59.88			

MODEL: Default  
 FILE NAME: S:\IP\Design\KKS\Signs Design\Contract-46556-Signs-Structure-Design-155-and-1200-County-Highway-84-co-Wisconsin-Rd\06272155\_Signage-IP-KK-COMBINED-06-28-21.dwg

USER NAME = plascencjal	DESIGNED - KK	REVISED -
DRAWN - KK / IP	REVISIONS -	
PLOT SCALE = 40,0000 * / in.	CHECKED - LP	REVISED -
PLOT DATE = 7/1/2021	DATE - 06/25/2021	REVISED -

**STATE OF ILLINOIS**  
**DEPARTMENT OF TRANSPORTATION**

<b>SIGN PANEL DESIGN</b>			
SCALE:	SHEET	OF	SHEETS
	STA.		TO STA.

F.A.I. RTE.	SECTION	COUNTY	TOTAL SHEETS	SHEET NO.
55	2021-128-5G	VARIOUS	178	133
			CONTRACT NO. 62P27	
		ILLINOIS	FED. AID PROJECT	

STRUCTURE NUMBER		1C022I055L272.9-000	
LOCATION		86 EXPRESSWAY	
SIZE (W x H)	EXIT PLAQUE	-	
	MAIN PANEL	16' X 8.5'	
MOUNTING / TYPE		OVERHEAD / CANTILEVER	
MOUNTING LOC (L, M, R)			
SHEETING / COLOR	BACKGROUND	TYPE:	ZZ
		COLOR:	GREEN
		TYPE:	
	LEGEND / BORDER	COLOR:	
		TYPE:	ZZ
		COLOR:	WHITE

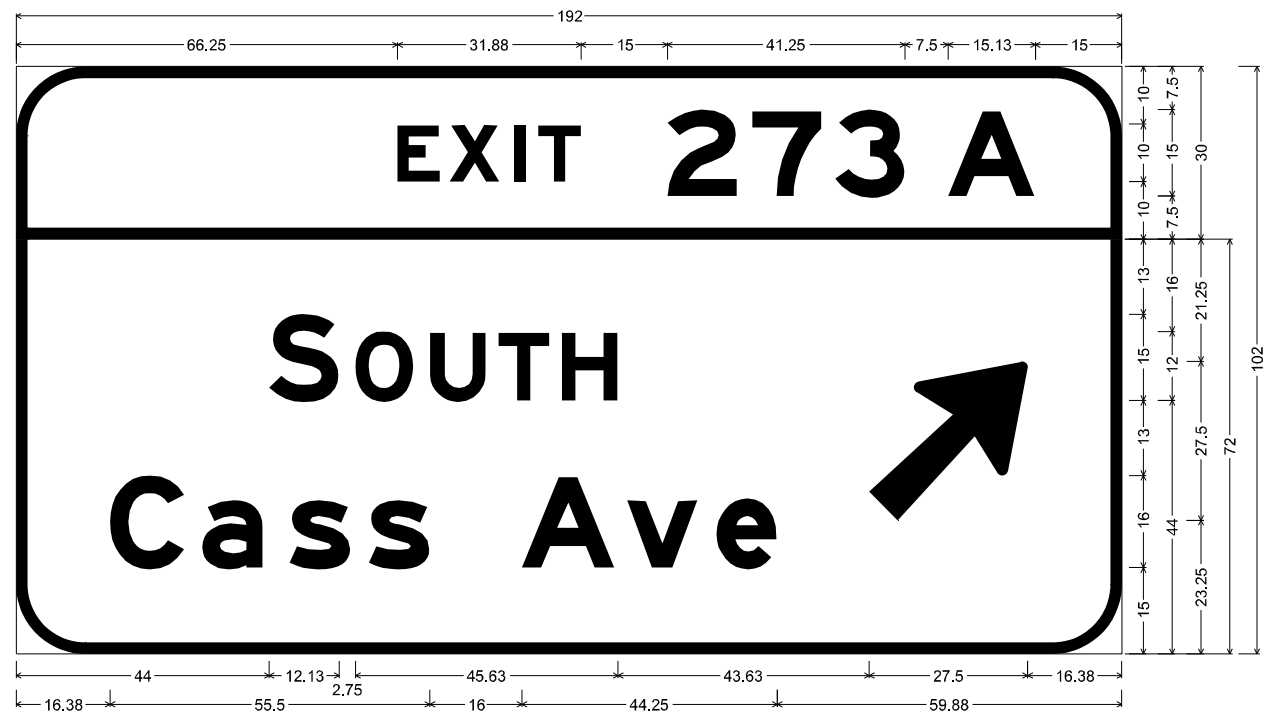

12.00" Radius, 2.00" Border, White on Green;  
 "EXIT", E Mod 2K 120% spacing; "273", E Mod 2K; "A", E Mod 2K;

12.00" Radius, 2.00" Border, White on Green;  
 "SOUTH", E Mod 2K; "Cass Ave", E Mod 2K; Arrow 160 - 35.00" 45°;

Table of widths and spaces

66.25	E	7.38	X	1.75	8.63	2.50	I	2.00	2.25	T	7.38	15.00	2	12.13	2.50	7	12.13	2.25	3	12.25	7.50	A	15.13	15.00
44.00	S	12.13	O	2.75	10.13	2.88	U	9.75	2.13	T	8.88	2.13	H	9.75	43.63	27.50	16.38							
16.38	C	12.88	a	3.00	10.63	4.63	s	10.50	3.25	s	10.63	16.00	A	16.13	2.00	v	12.38	3.25	e	10.50	59.88			

MODEL: D:\p\h  
 FILE NAME: S:\IP\Design\KKS\Signs Design\Contract-46556-Signs-Structure-Design-155-and-1200-County-1-Enc-84-co-Webor-Rd\00D\62P27-155\_Signs\IP-KK-CO\BIBRED-06-28-21.dwg

USER NAME = plascencjal	DESIGNED - KK	REVISED -
DRAWN - KK / IP	REVISIONS -	
PLOT SCALE = 40,0000 * / in.	CHECKED - LP	REVISED -
PLOT DATE = 7/1/2021	DATE - 06/25/2021	REVISED -

**STATE OF ILLINOIS**  
**DEPARTMENT OF TRANSPORTATION**

<b>SIGN PANEL DESIGN</b>			
SCALE:	SHEET	OF	SHEETS
STA.	TO STA.		

F.A.I. RTE.	SECTION	COUNTY	TOTAL SHEETS	SHEET NO.
55	2021-128-SG	VARIOUS	178	134
CONTRACT NO. 62P27				
ILLINOIS FED. AID PROJECT				

**DETAILS**

"TOLL" PLAQUE DETAIL DESIGN

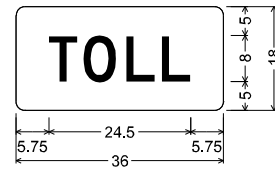

1.50" Radius, 0.00" Border, White on Yellow;

"TOLL" Black, D 2K;

Table of widths and spaces

T	4.88	1.13	O	5.63	1.75	L	5.00	1.13	L	5.00	5.75
---	------	------	---	------	------	---	------	------	---	------	------

STRUCTURE NUMBER		1S022I055L271.1-000	
LOCATION		87A EXPRESSWAY	
SIZE (W x H)	EXIT PLAQUE	-	
	MAIN PANEL	11' X 12'	
MOUNTING / TYPE		OVERHEAD / TRUSS	
MOUNTING LOC (L, M, R)		LEFT	
SHEETING / COLOR	BACKGROUND	TYPE:	ZZ
		COLOR:	GREEN
		TYPE:	
	COLOR:		
LEGEND / BORDER	TYPE:	ZZ	
	COLOR:	WHITE	
	TYPE:		
COLOR:			

STRUCTURE NUMBER		1S022I055L271.1-000	
LOCATION		87B EXPRESSWAY	
SIZE (W x H)	EXIT PLAQUE	-	
	MAIN PANEL	13.5' X 10.5'	
MOUNTING / TYPE		OVERHEAD / TRUSS	
MOUNTING LOC (L, M, R)		MIDDLE	
SHEETING / COLOR	BACKGROUND	TYPE:	ZZ
		COLOR:	GREEN
		TYPE:	
	COLOR:		
LEGEND / BORDER	TYPE:	ZZ	
	COLOR:	WHITE	
	TYPE:		
COLOR:			

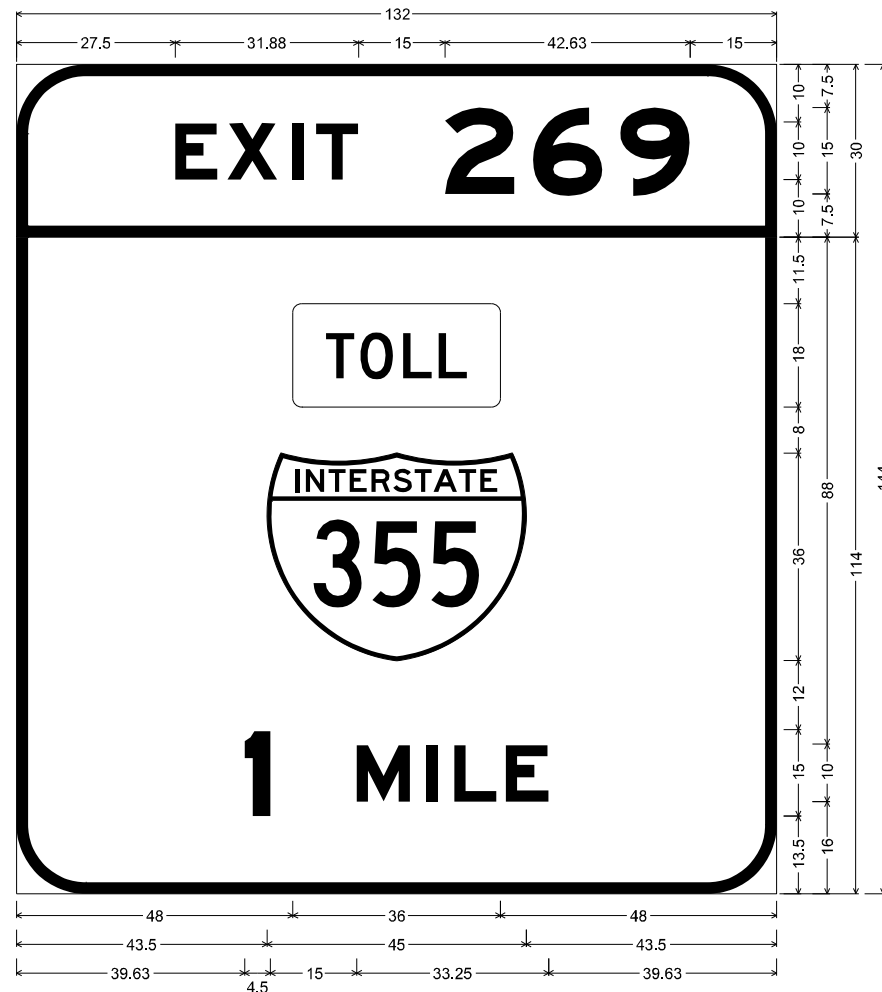

12.00" Radius, 2.00" Border, White on Green;  
"EXIT", E Mod 2K 120% spacing; "269", E Mod 2K;

12.00" Radius, 2.00" Border, White on Green;  
Rounded Rectangle 1.50" Radius Yellow;  
"1 MILE", E Mod 2K;

Table of widths and spaces

27.50	E	7.50	1.63	X	8.75	2.50	I	2.00	2.13	T	7.38	15.00	2	12.13	3.13	6	12.25	3.00	9	12.13	15.00
48.00		36.00	48.00																		
43.50		45.00	43.50																		
39.63	1	4.50	15.00	M	9.25	2.88	I	2.00	2.75	L	7.38	1.63	E	7.38	39.63						

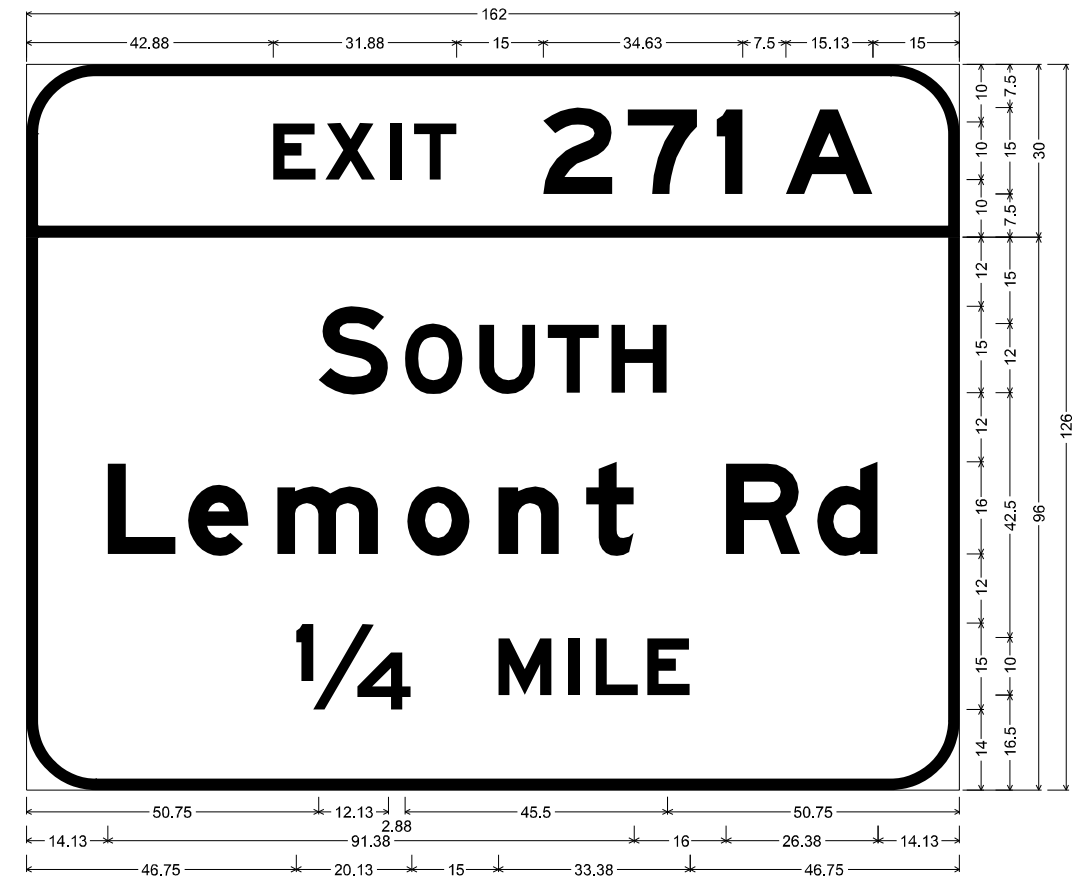

12.00" Radius, 2.00" Border, White on Green;  
"EXIT", E Mod 2K 120% spacing; "271", E Mod 2K; "A", E Mod 2K;

12.00" Radius, 2.00" Border, White on Green;  
"SOUTH", E Mod 2K; "Lemont Rd", E Mod 2K; "1/4 MILE", E Mod 2K;

Table of widths and spaces

42.88	E	7.38	1.63	X	8.75	2.50	I	2.00	2.13	T	7.38	15.00	2	12.25	2.50	7	12.13	3.38	1	4.50	7.50	A	15.13	15.00
50.75	S	12.13	2.88	O	10.00	2.88	U	9.75	2.13	T	8.88	2.13	H	9.75	50.75									
14.13	L	11.88	2.00	e	10.63	4.88	m	17.63	5.00	o	10.88	4.88	n	10.63	4.63	t	8.25	16.00	R	13.00	2.88	d	10.63	14.13
46.75	1/4	20.13	15.00	M	9.38	2.75	I	2.00	2.75	L	7.50	1.50	E	7.50	46.75									

MODEL: D:\p\p\Design\KKS\Signs - Design\Contract-48556-Signs-Structure-Design-455-and-230-County-4-Line-84-co-Wabor-Rn\CADD\62P27155\_Signs\KKS-IP-KK-CO\BIBRED-06-28-21.com

USER NAME = plascencjal	DESIGNED - KK	REVISED -
DRAWN - KK / IP	REVISIONS -	
PLOT SCALE = 40,0000 * / in.	CHECKED - LP	REVISED -
PLOT DATE = 7/1/2021	DATE - 06/25/2021	REVISED -

**STATE OF ILLINOIS  
DEPARTMENT OF TRANSPORTATION**

**SIGN PANEL DESIGN**

SCALE: SHEET OF SHEETS STA. TO STA.

F.A.I. RTE.	SECTION	COUNTY	TOTAL SHEETS	SHEET NO.
55	2021-128-SG	VARIOUS	178	135
CONTRACT NO. 62P27				
ILLINOIS FED. AID PROJECT				

STRUCTURE NUMBER		1S022I055L271.1-000	
LOCATION		87C EXPRESSWAY	
SIZE (W x H)	EXIT PLAQUE	-	
	MAIN PANEL	17.5' X 8.5'	
MOUNTING / TYPE		OVERHEAD / TRUSS	
MOUNTING LOC (L, M, R)		RIGHT	
SHEETING / COLOR	BACKGROUND	TYPE:	ZZ
		COLOR:	GREEN
		TYPE:	
	LEGEND / BORDER	COLOR:	
		TYPE:	ZZ
		COLOR:	WHITE

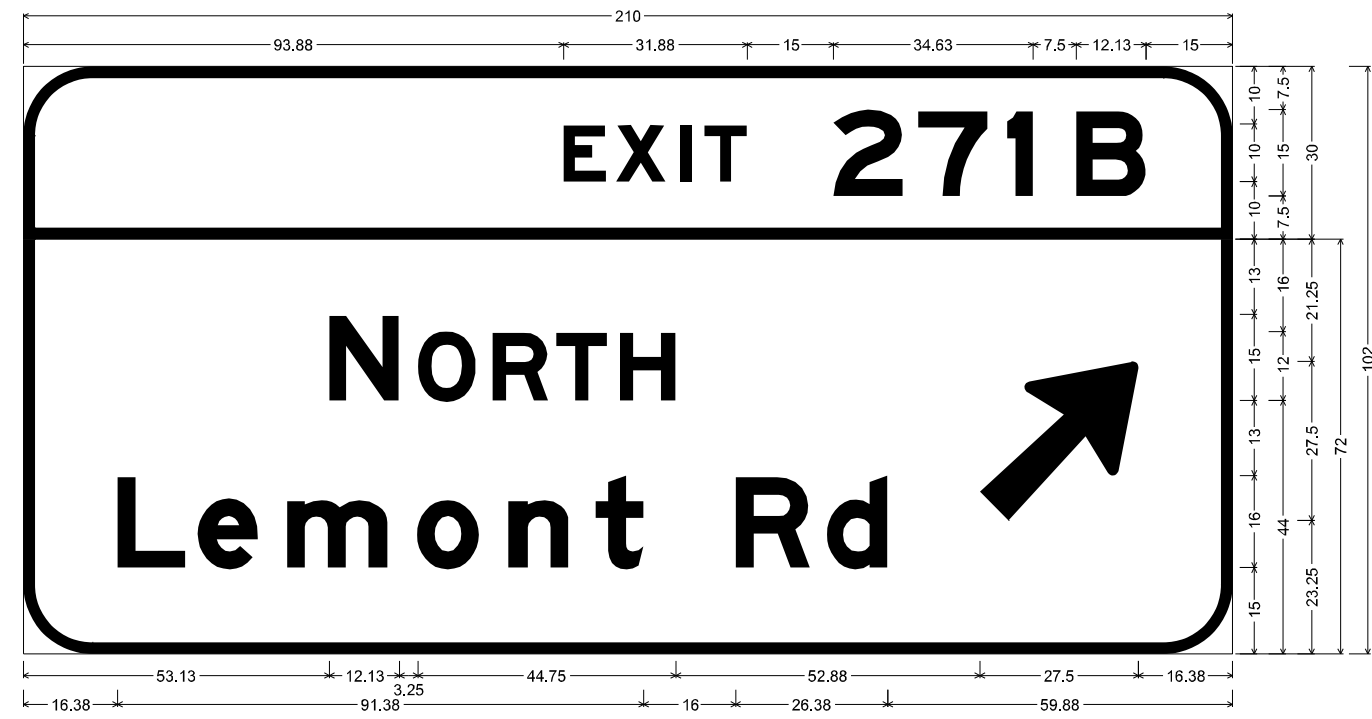

12.00" Radius, 2.00" Border, White on Green;  
 "EXIT", E Mod 2K 120% spacing; "271", E Mod 2K; "B", E Mod 2K;  
 12.00" Radius, 2.00" Border, White on Green;  
 "NORTH", E Mod 2K; "Lemont Rd", E Mod 2K; Arrow 160 - 35.00" 45";  
 Table of widths and spaces

93.88	E	7.38	1.63	X	8.75	2.50	2.00	2.13	T	7.38	15.00	12.25	2.50	7	12.13	3.38	4.50	i	7.50	B	12.13	15.00	
53.13	N	12.13	3.25	O	10.13	2.88	9.75	1.25	T	8.88	2.25	9.63	52.88	H	27.50	16.38							
16.38	L	11.88	2.00	e	10.63	4.88	m	17.63	5.00	o	10.88	4.88	n	10.63	4.63	8.25	16.00	R	13.00	2.88	d	10.63	59.88

MODEL: D:\p\h  
 FILE NAME: S:\IP\Design\KKS\Signs Design\Contract-46556-Signs-Structure-Design-155-and-1200-County-4-Enc-84-co-Water-Rd\CADD\62P27-155\_Signs-IP-KK-COMBINED-06-28-21.dwg

USER NAME = plascencjal	DESIGNED - KK	REVISED -
	DRAWN - KK / IP	REVISED -
PLOT SCALE = 40,0000 * / in.	CHECKED - LP	REVISED -
PLOT DATE = 7/1/2021	DATE - 06/25/2021	REVISED -

**STATE OF ILLINOIS**  
**DEPARTMENT OF TRANSPORTATION**

<b>SIGN PANEL DESIGN</b>	
SCALE:	SHEET OF SHEETS STA. TO STA.

F.A.I. RTE.	SECTION	COUNTY	TOTAL SHEETS	SHEET NO.
55	2021-128-5G	VARIOUS	178	136
CONTRACT NO. 62P27				
ILLINOIS FED. AID PROJECT				

**DETAILS**

"TOLL" PLAQUE DETAIL DESIGN

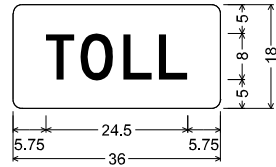

1.50" Radius, 0.00" Border, White on Yellow;  
 "TOLL" Black, D 2K;  
 Table of widths and spaces

5.75	T	4.88	1.13	O	5.63	1.75	L	5.00	1.13	L	5.00	5.75
------	---	------	------	---	------	------	---	------	------	---	------	------

STRUCTURE NUMBER		1C0221055L270.5-000	
LOCATION		89 EXPRESSWAY	
SIZE (W x H)	EXIT PLAQUE	-	
	MAIN PANEL	14.5' X 13'	
MOUNTING / TYPE		OVERHEAD / CANTILEVER	
MOUNTING LOC (L, M, R)			
SHEETING / COLOR	BACKGROUND	TYPE:	ZZ
		COLOR:	GREEN
		TYPE:	
	LEGEND / BORDER	COLOR:	
		TYPE:	ZZ
		COLOR:	WHITE
	TYPE:		
	COLOR:		

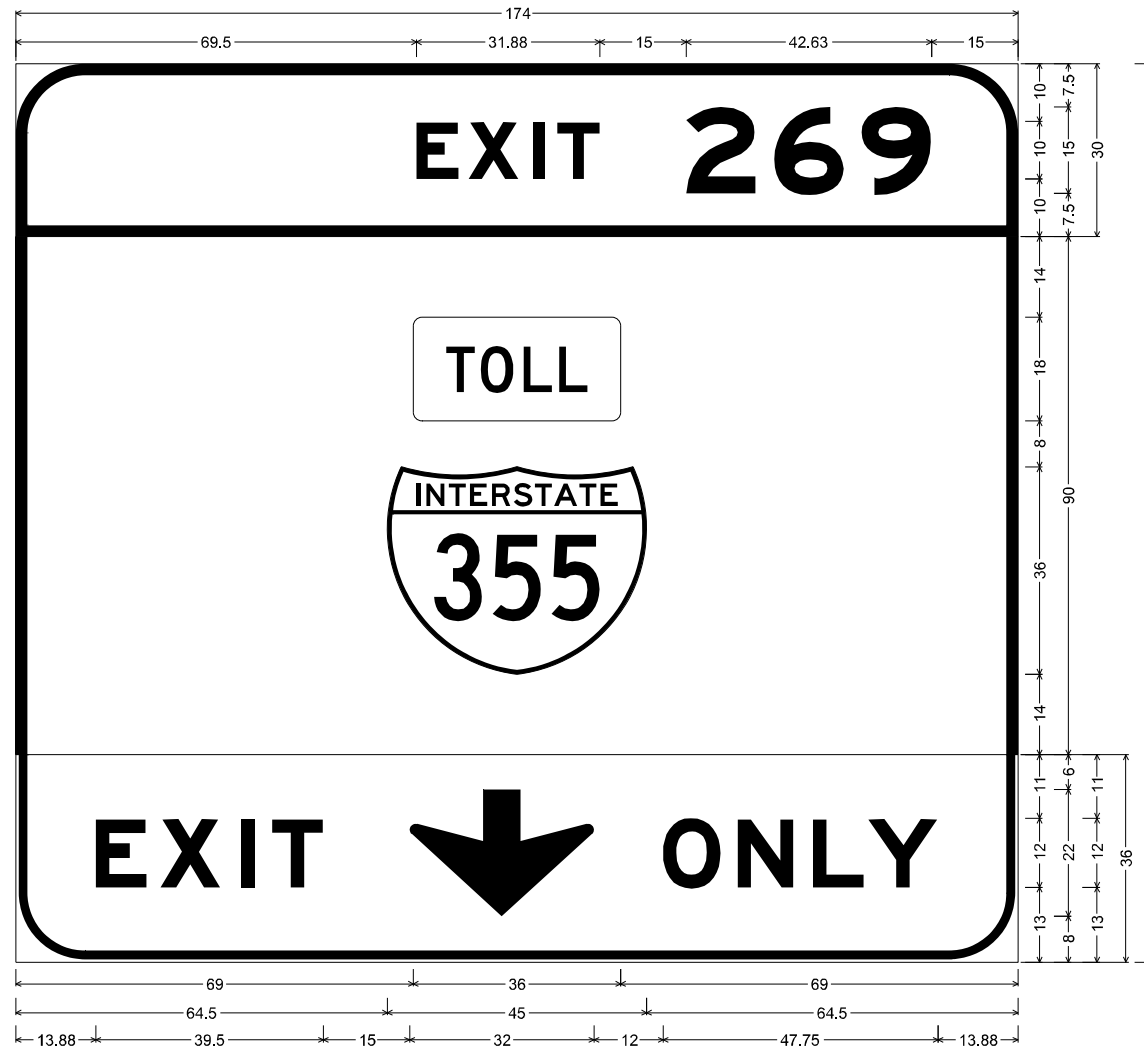

12.00" Radius, 2.00" Border, White on Green;  
 "EXIT", E Mod 2K 120% spacing; "269", E Mod 2K;  
 12.00" Radius, 2.00" Border, White on Green;  
 Rounded Rectangle 1.50" Radius Yellow;  
 12.00" Radius, 1.50" Border, 0.50" Indent, Black on Yellow;  
 "EXIT", E Mod 2K 140% spacing; Down Arrow 22.00" 270"; "ONLY", E Mod 2K;  
 Table of widths and spaces

69.50	E	7.50	1.63	X	8.75	2.50	I	2.00	2.13	T	7.38	15.00	Z	12.13	3.13	6	12.25	3.00	9	12.13	15.00				
69.00		36.00	69.00																						
64.50		45.00	64.50																						
13.88	E	8.88	2.38	X	10.38	3.50	I	2.50	3.00	T	8.88	15.00	↕	32.00	12.00	O	10.00	2.88	N	9.75	3.38	8.88	0.75	12.13	13.88

MODEL: D:\p\h  
 FILE NAME: S:\IP\Design\KKS\Signs Design\Contract-46556-Signs-Structure-Design-155-and-1200-County-4-Enc-84-co-Water-Rd\00DD\6272155\_Signs-IP-KK-COMBINED-06-28-21.dwg

USER NAME = plascencjal	DESIGNED - KK	REVISED -
DRAWN - KK / IP	REVISIONS -	
PLOT SCALE = 40,0000 * / in.	CHECKED - LP	REVISED -
PLOT DATE = 7/1/2021	DATE - 06/25/2021	REVISED -

**STATE OF ILLINOIS  
 DEPARTMENT OF TRANSPORTATION**

**SIGN PANEL DESIGN**

SCALE: SHEET OF SHEETS STA. TO STA.

F.A.I. RTE.	SECTION	COUNTY	TOTAL SHEETS	SHEET NO.
55	2021-128-SG	VARIOUS	178	137
CONTRACT NO. 62P27			ILLINOIS FED. AID PROJECT	

STRUCTURE NUMBER		1S022I055L270.4-000	
LOCATION		90A	EXPRESSWAY
SIZE (W x H)	EXIT PLAQUE	-	
	MAIN PANEL	28.5' X 10.5'	
MOUNTING / TYPE		OVERHEAD / TRUSS	
MOUNTING LOC (L, M, R)		LEFT	
SHEETING / COLOR	BACKGROUND	TYPE:	ZZ
		COLOR:	GREEN
		TYPE:	
	LEGEND / BORDER	COLOR:	
		TYPE:	ZZ
		COLOR:	WHITE

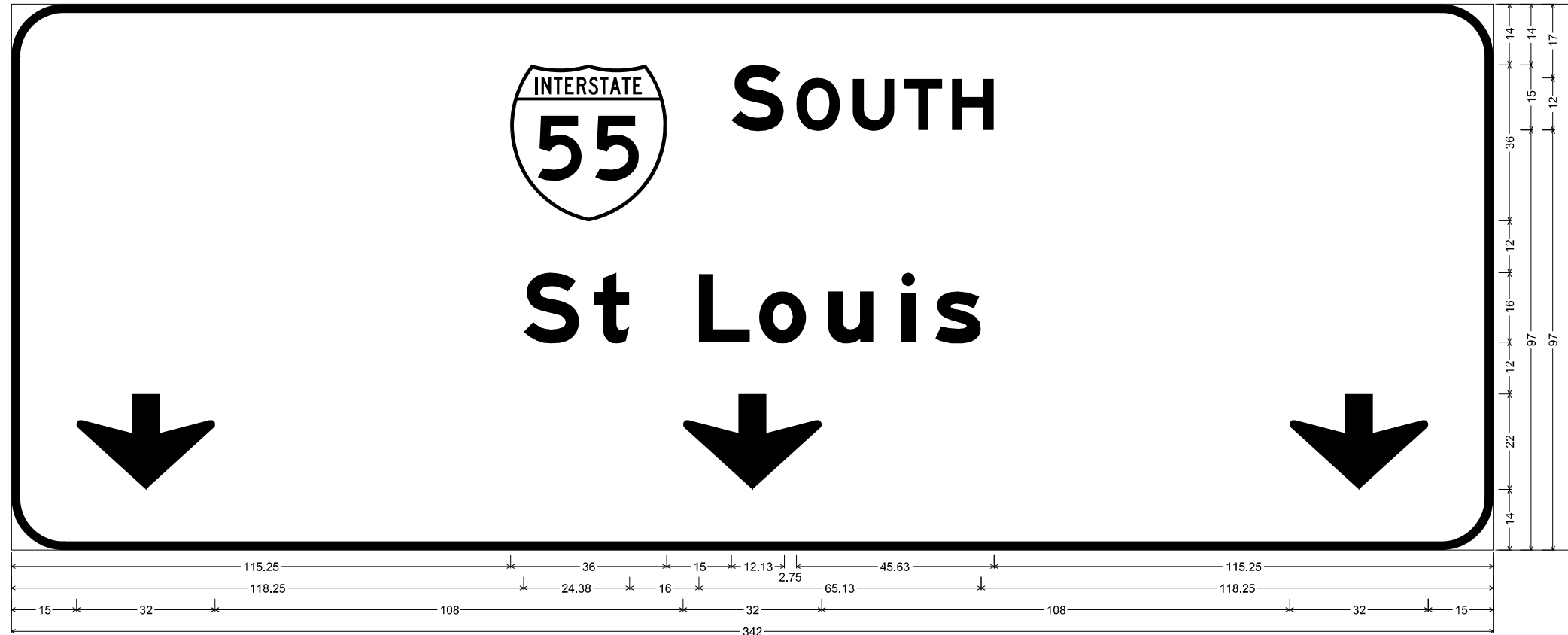

12.00" Radius, 2.00" Border, White on Green;  
 "SOUTH", E Mod 2K; "St Louis", E Mod 2K; Down Arrow 22.00" 270°; Down Arrow 22.00" 270°; Down Arrow 22.00" 270°;  
 Table of widths and spaces

115.25	36.00	15.00	S	12.13	2.75	O	10.13	2.88	9.75	2.13	8.88	2.13	H	9.75	115.25			
118.25	S	12.88	3.25	t	8.25	L	11.88	2.13	10.88	4.88	u	10.63	6.38	i	3.25	4.63	10.50	118.25
15.00	32.00	108.00	32.00	108.00	32.00	15.00												

MODEL: Default  
 FILE NAME: S:\WP\Design\KKS\Signs\_Design\Contract-48556-Signs\_Structure-Design-155\_and-1200-County4-Line-84-co-Water-Rd\CADD\62P27-155\_Signs-IP-KK-CO\BIBRED-06-28-21.dwg

USER NAME = plascencjal	DESIGNED - KK	REVISED -
DRAWN - KK / IP	REVISIONS	
PLOT SCALE = 40,0000 * / in.	CHECKED - LP	REVISED -
PLOT DATE = 7/1/2021	DATE - 06/25/2021	REVISED -

**STATE OF ILLINOIS  
DEPARTMENT OF TRANSPORTATION**

**SIGN PANEL DESIGN**

SCALE: SHEET OF SHEETS STA. TO STA.

F.A.I. RTE.	SECTION	COUNTY	TOTAL SHEETS	SHEET NO.
55	2021-128-SG	VARIOUS	178	138
CONTRACT NO. 62P27			ILLINOIS FED. AID PROJECT	

**DETAILS**

"TOLL" PLAQUE DETAIL DESIGN

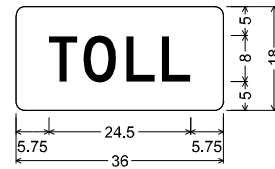

1.50" Radius, 0.00" Border, White on Yellow;

"TOLL" Black, D 2K;

Table of widths and spaces

	T	O	L	L
5.75	4.88	1.13	5.63	1.75
	L	L		
	5.00	1.13	5.00	5.75

STRUCTURE NUMBER		1S022I055L270.4-000	
LOCATION		90B EXPRESSWAY	
SIZE (W x H)	EXIT PLAQUE	-	
	MAIN PANEL	18.5' X 13'	
MOUNTING / TYPE		OVERHEAD / TRUSS	
MOUNTING LOC (L, M, R)		RIGHT	
SHEETING / COLOR	BACKGROUND	TYPE:	ZZ
		COLOR:	GREEN
		TYPE:	
	LEGEND / BORDER	COLOR:	
		TYPE:	ZZ
		COLOR:	WHITE
	TYPE:		
	COLOR:		

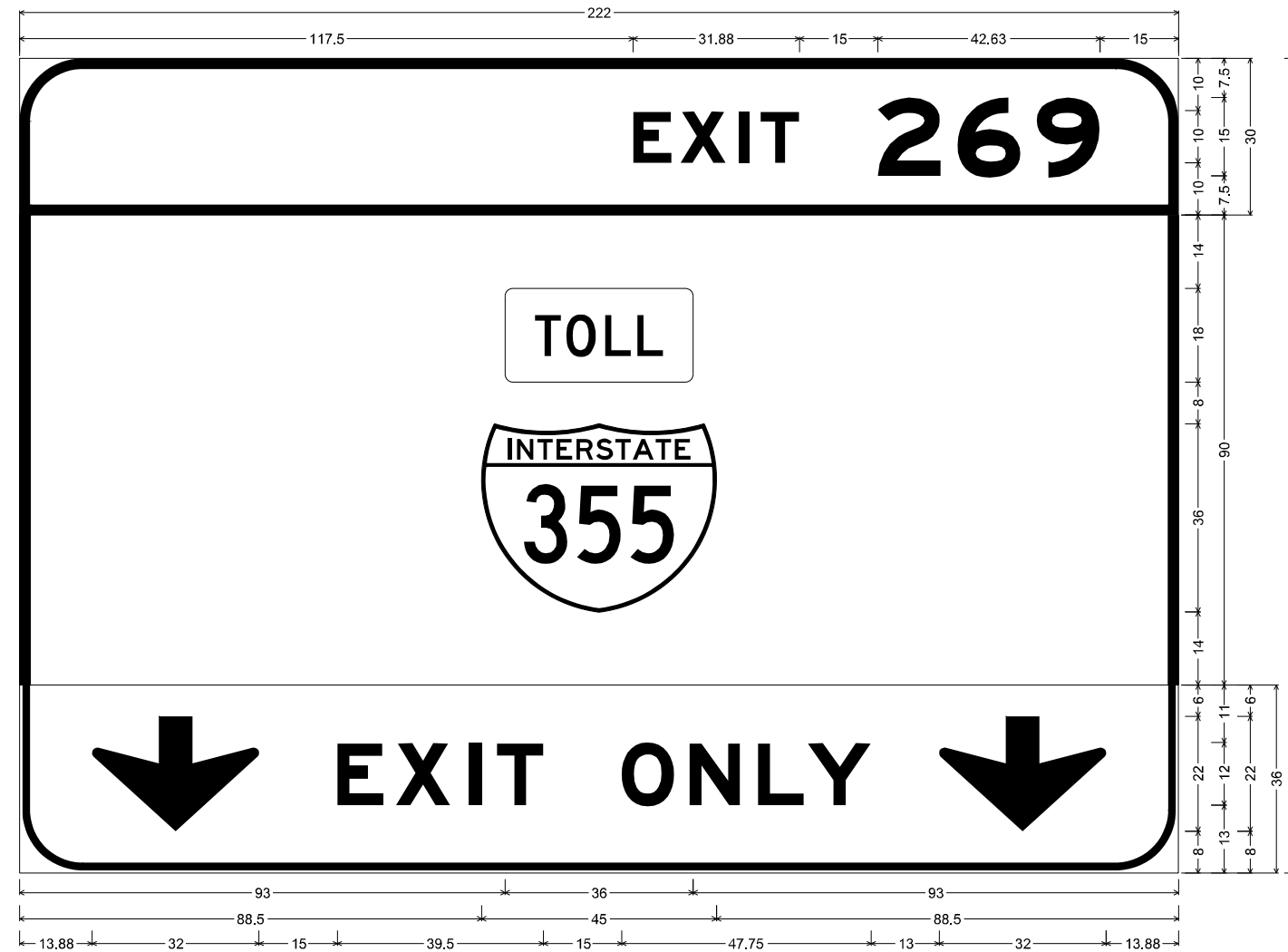

12.00" Radius, 2.00" Border, White on Green;  
 "EXIT", E Mod 2K 120% spacing; "269", E Mod 2K;

12.00" Radius, 2.00" Border, White on Green;  
 Rounded Rectangle 1.50" Radius Yellow;

12.00" Radius, 1.50" Border, 0.50" Indent, Black on Yellow;  
 Down Arrow 22.00" 270"; "EXIT", E Mod 2K specified length; "ONLY", E Mod 2K specified length; Down Arrow 22.00" 270";

Table of widths and spaces

117.50	E	7.50	X	1.63	I	2.50	T	2.13	2	15.00	6	12.25	3.00	9	12.13	15.00
93.00		36.00		93.00												
88.50		45.00		88.50												
13.88	↓	32.00	E	15.00	X	8.88	I	2.38	T	3.13	O	10.00	N	2.88	L	8.88
			2.38		3.50		3.13		8.88		0.75		12.13		13.00	↓
																32.00
																13.88

MODEL: D:\p\h...  
 FILE NAME: S:\IP\Design\KKS\Signs Design\Contract-46556-Signs-Structure-Design-155-and-1200-County-4-Enc-84-co-Water-Rd\CADD\62P27-155\_Signs-IP-KK-COMBINED-06-28-21.dwg

USER NAME = plascencjal	DESIGNED - KK	REVISED -
DRAWN - KK / IP	REVISIONS -	
PLOT SCALE = 40,0000 * / in.	CHECKED - LP	REVISED -
PLOT DATE = 7/1/2021	DATE - 06/25/2021	REVISED -

**STATE OF ILLINOIS**  
**DEPARTMENT OF TRANSPORTATION**

<b>SCALE:</b>		<b>SHEET</b>		<b>OF</b>		<b>SHEETS</b>		<b>STA.</b>		<b>TO STA.</b>	
---------------	--	--------------	--	-----------	--	---------------	--	-------------	--	----------------	--

F.A.I. RTE.	SECTION	COUNTY	TOTAL SHEETS	SHEET NO.
55	2021-128-SG	VARIOUS	178	139
CONTRACT NO. 62P27				
ILLINOIS FED. AID PROJECT				

STRUCTURE NUMBER		1S022I055L270.0-000	
LOCATION		91A EXPRESSWAY	
SIZE (W x H)	EXIT PLAQUE	-	
	MAIN PANEL	12' X 10.5'	
MOUNTING / TYPE		OVERHEAD / TRUSS	
MOUNTING LOC (L, M, R)		LEFT	
SHEETING / COLOR	BACKGROUND	TYPE:	ZZ
		COLOR:	GREEN
		TYPE:	
		COLOR:	
	LEGEND / BORDER	TYPE:	ZZ
		COLOR:	WHITE
		TYPE:	
		COLOR:	

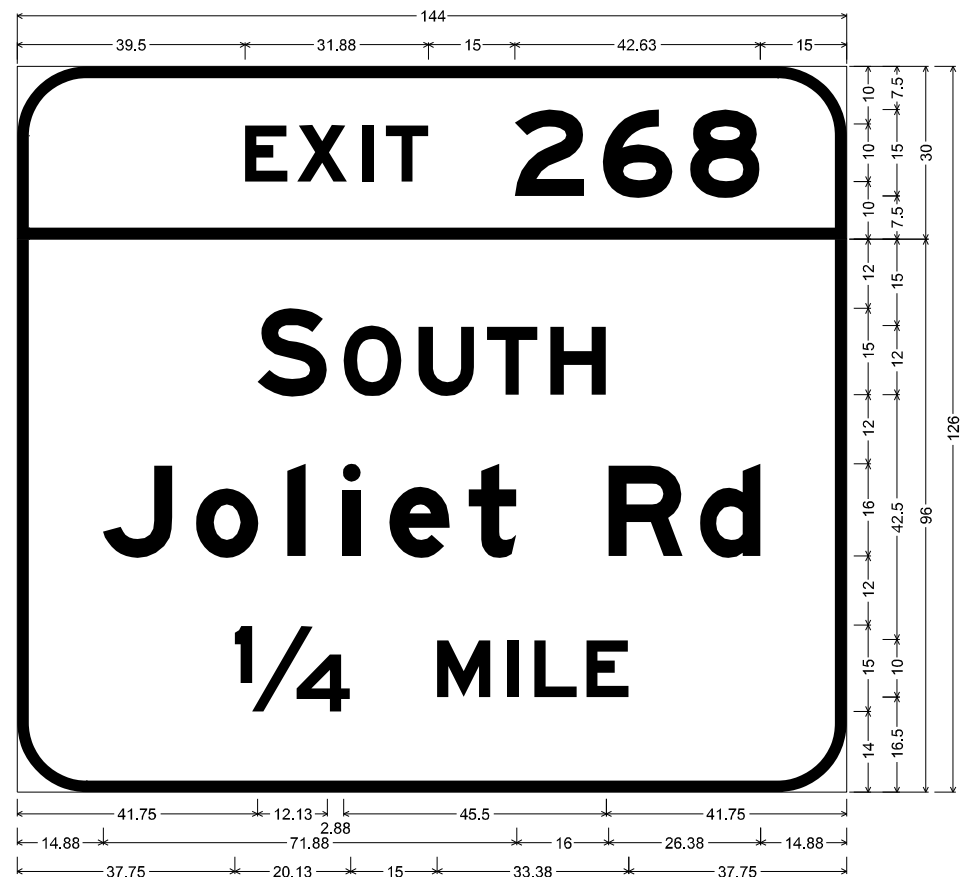

12.00" Radius, 2.00" Border, White on Green;  
 "EXIT", E Mod 2K 120% spacing; "268", E Mod 2K;

12.00" Radius, 2.00" Border, White on Green;  
 "SOUTH", E Mod 2K; "Joliet Rd", E Mod 2K; "1/4 MILE", E Mod 2K;

Table of widths and spaces

39.50	E	7.50	1.63	X	8.75	2.50	I	2.00	2.13	T	7.38	15.00	2	12.13	3.13	6	12.25	3.00	B	12.13	15.00			
41.75	S	12.13	2.88	O	10.00	2.88	U	9.75	2.13	T	8.88	2.13	H	9.75	41.75									
14.88	J	12.13	4.00	o	10.88	5.00	i	3.25	6.38	i	3.13	5.00	e	10.50	3.25	t	8.38	16.00	R	12.88	2.88	d	10.63	14.88
37.75	1/4	20.13	15.00	M	9.38	2.75	I	2.00	2.75	L	7.50	1.50	E	7.50	37.75									

MODEL: D:\p\h  
 FILE NAME: S:\IP\Design\KKS\Signs Design\Contract-46556-Signs-Structure-Design-155-and-1200-County-4-Enc-84-co-Water-Rd\CDD\62P27155\_Signs-IP-KK-CO\BIBED-06-28-21.dwg

USER NAME = plascencjal	DESIGNED - KK	REVISED -
DRAWN - KK / IP	CHECKED - LP	REVISED -
PLOT SCALE = 40,0000 * / in.	DATE - 06/25/2021	REVISED -
PLOT DATE = 7/1/2021		

**STATE OF ILLINOIS**  
**DEPARTMENT OF TRANSPORTATION**

<b>SIGN PANEL DESIGN</b>			
SCALE:	SHEET	OF	SHEETS
	STA.		TO STA.

F.A.I. RTE.	SECTION	COUNTY	TOTAL SHEETS	SHEET NO.
55	2021-128-SG	VARIOUS	178	140
CONTRACT NO. 62P27				
ILLINOIS FED. AID PROJECT				



MODEL: D:\p\p\Drawings\Signs\Design\Contract-48545-Signs-Structure\Structure-Design-48545-Signs-Structure\WorBook\CADD\62P27-155\_Signs\Sign-1-KK-COM\BRED-06-28-21.dwg  
 FILE NAME: Sign\Drawings\Signs\Design\Contract-48545-Signs-Structure\Structure-Design-48545-Signs-Structure\WorBook\CADD\62P27-155\_Signs\Sign-1-KK-COM\BRED-06-28-21.dwg

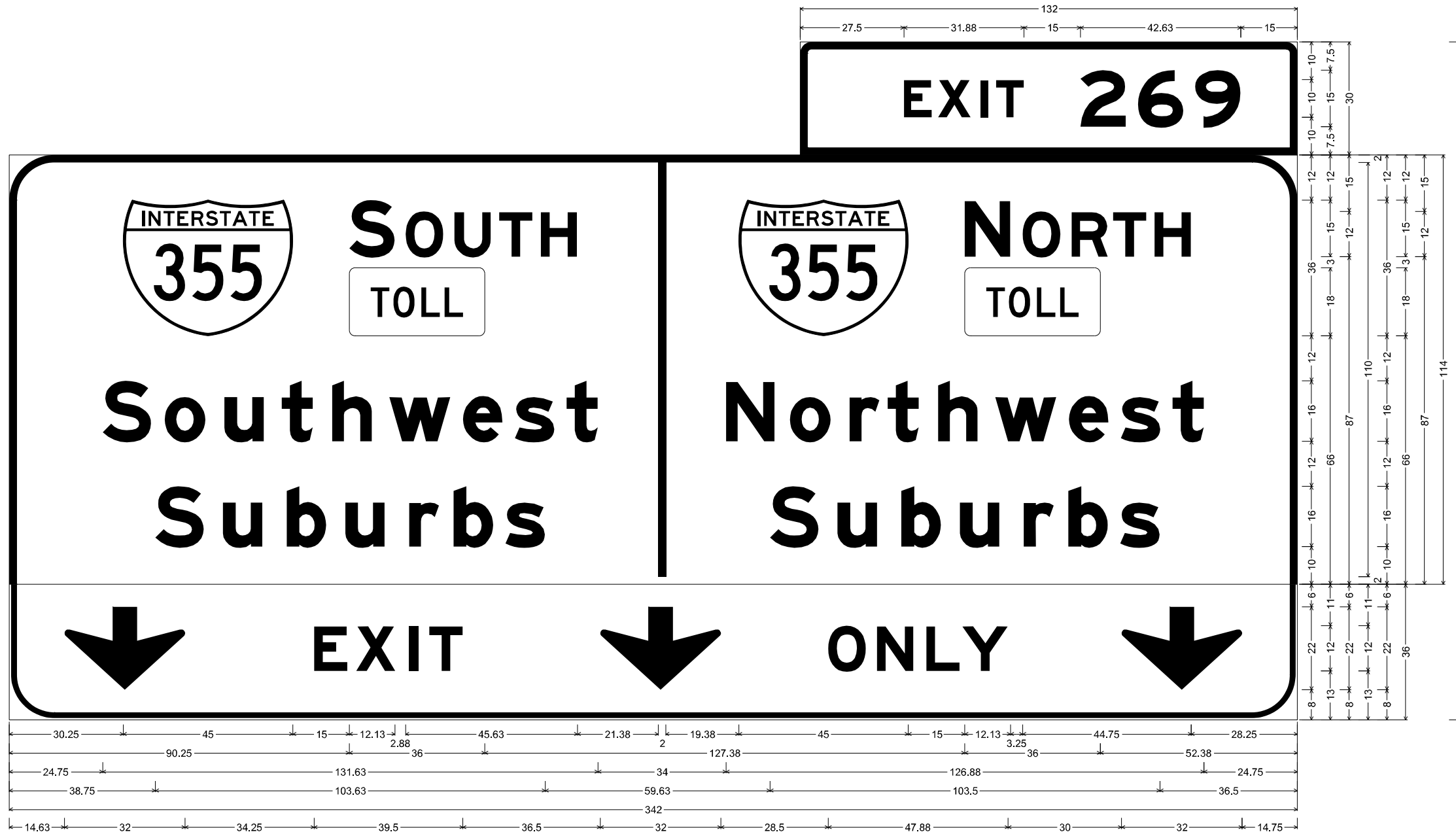

3.00" Radius, 2.00" Border, White on Green;  
 "EXIT", E Mod 2K 120% spacing; "269", E Mod 2K;  
 12.00" Radius, 2.00" Border, White on Green;  
 "SOUTH", E Mod 2K; Rounded Rectangle 1.50" Radius Yellow;  
 "Southwest", E Mod 2K; "Suburbs", E Mod 2K; "NORTH", E Mod 2K; Rounded Rectangle 1.50" Radius Yellow;  
 "Northwest", E Mod 2K; "Suburbs", E Mod 2K;  
 12.00" Radius, 1.50" Border, 0.50" Indent, Black on Yellow;  
 Down Arrow 22.00" 270"; "EXIT", E Mod 2K 140% spacing; Down Arrow 22.00" 270"; "ONLY", E Mod 2K; Down Arrow 22.00" 270";  
 Table of widths and spaces

237.50	E	7.50	1.63	X	8.75	2.50	I	2.00	2.13	T	7.38	15.00	Z	12.13	3.13	6	12.25	3.00	9	12.13	15.00																																
30.25	45.00	15.00	S	12.13	2.88	O	10.13	2.88	U	9.63	2.25	T	8.88	2.13	H	9.75	21.38	2.00	19.38	45.00	15.00	12.13	3.25	O	10.13	2.88	R	9.75	1.25	T	8.88	2.13	H	9.75	28.13																		
90.25	36.00	127.38	36.00	52.38																																																	
24.75	13.00	3.50	O	10.88	5.00	U	10.50	4.75	T	8.25	5.13	H	10.50	4.75	W	16.25	3.25	E	10.50	3.25	S	10.50	3.25	T	8.25	34.00	N	13.00	4.00	O	10.88	5.00	R	8.00	2.00	T	8.38	5.13	H	10.50	4.75	W	16.25	3.25	E	10.50	3.25	S	10.50	3.25	T	8.25	24.88
38.75	13.00	5.00	U	10.50	6.38	B	10.63	5.00	U	10.50	6.38	R	8.00	3.88	B	10.50	3.25	S	10.50	59.75	S	13.00	4.88	U	10.63	6.38	B	10.50	5.00	U	10.50	6.50	R	8.00	3.75	B	10.63	3.13	S	10.63	36.50												
14.63	32.00	34.25	E	8.88	2.38	X	10.50	3.50	I	2.38	3.00	T	8.88	36.50	32.00	28.50	O	10.13	2.88	N	9.75	3.38	L	8.88	0.63	Y	12.13	30.13	32.00	14.75																							

STRUCTURE NUMBER		1S022I055L270.0-000	
LOCATION		91B & 91C EXPRESSWAY	
SIZE (W x H)	EXIT PLAQUE	11' X 2.5'	
	MAIN PANEL	28.5' X 12.5'	
MOUNTING / TYPE		OVERHEAD / TRUSS	
MOUNTING LOC (L, M, R)		RIGHT	
SHEETING / COLOR	BACKGROUND	TYPE:	ZZ
		COLOR:	GREEN
		TYPE:	
		COLOR:	
	LEGEND / BORDER	TYPE:	ZZ
		COLOR:	WHITE
		TYPE:	
		COLOR:	

**DETAILS**

"TOLL" PLAQUE DETAIL DESIGN

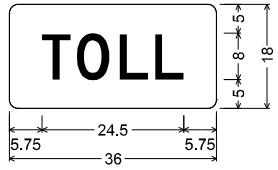

1.50" Radius, 0.00" Border, White on Yellow;  
 "TOLL" Black, D 2K;  
 Table of widths and spaces

T	4.88	1.13	O	5.63	1.75	L	5.00	1.13	L	5.00	5.75
---	------	------	---	------	------	---	------	------	---	------	------

USER NAME = plascencia	DESIGNED - KK	REVISED -
PLOT SCALE = 40,0000 */ in.	DRAWN - KK / IP	REVISED -
PLOT DATE = 7/1/2021	CHECKED - LP	REVISED -
	DATE - 06/25/2021	REVISED -

**STATE OF ILLINOIS**  
**DEPARTMENT OF TRANSPORTATION**

SCALE:		SHEET	OF	SHEETS	STA.	TO	STA.
--------	--	-------	----	--------	------	----	------

F.A.I. RTE.	SECTION	COUNTY	TOTAL SHEETS	SHEET NO.
55	2021-128-SG	VARIOUS	178	141
CONTRACT NO. 62P27				
ILLINOIS FED. AID PROJECT				

**DETAILS**

"TOLL" PLAQUE DETAIL DESIGN

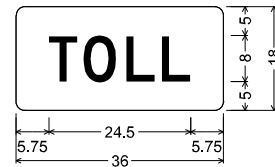

1.50" Radius, 0.00" Border, White on Yellow;  
"TOLL" Black, D 2K;

Table of widths and spaces

T	O	L	L
5.75	4.88	1.13	5.63
1.75	5.00	1.13	5.00
5.75			

STRUCTURE NUMBER		1B0221055L269. 8-000	
LOCATION		92A EXPRESSWAY	
SIZE (W x H)	EXIT PLAQUE	-	
MAIN PANEL		14.5' X 13'	
MOUNTING / TYPE		OVERHEAD / BRIDGE	
MOUNTING LOC (L, M, R)		LEFT	
SHEETING / COLOR	BACKGROUND	TYPE:	ZZ
		COLOR:	GREEN
		TYPE:	
	LEGEND / BORDER	TYPE:	ZZ
		COLOR:	WHITE
		TYPE:	

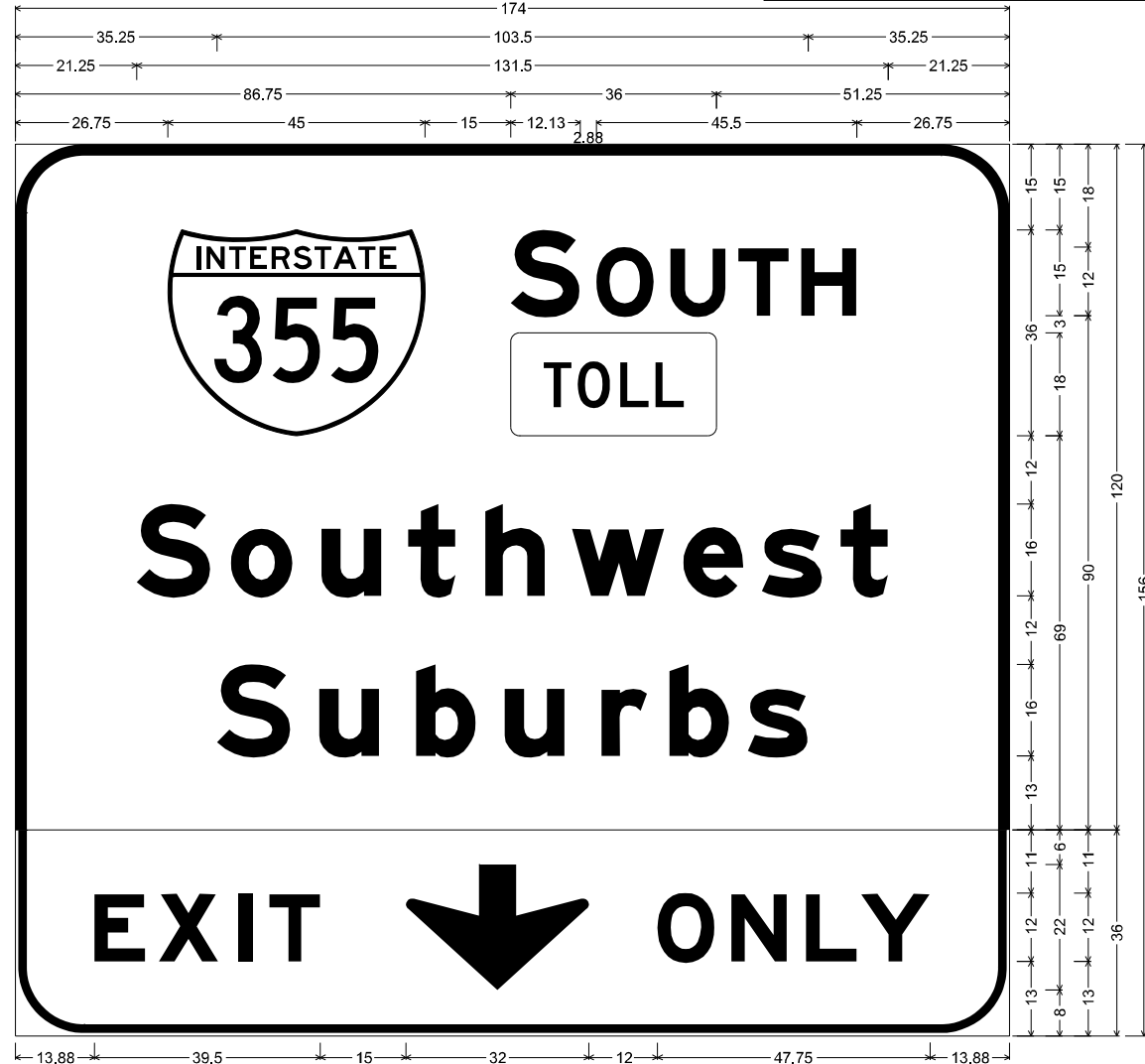

12.00" Radius, 2.00" Border, White on Green;  
"SOUTH", E Mod 2K; Rounded Rectangle 1.50" Radius Yellow;  
"Southwest", E Mod 2K; "Suburbs", E Mod 2K;

12.00" Radius, 1.50" Border, 0.50" Indent, Black on Yellow;  
"EXIT", E Mod 2K 140% spacing; Down Arrow 22.00" 270"; "ONLY", E Mod 2K;

Table of widths and spaces

26.75	45.00	15.00	12.13	2.88	10.00	2.88	9.75	2.13	8.88	2.13	9.75	26.75						
86.75	36.00	51.25																
21.25	13.00	3.50	10.88	4.88	10.63	4.63	8.25	5.13	10.63	4.63	16.25	3.25	10.63	3.13	10.63	3.13	8.38	21.25
35.25	13.00	4.88	10.63	6.38	10.50	5.00	10.50	6.50	8.00	3.75	10.63	3.13	10.63	35.25				
13.88	8.88	2.38	10.38	3.50	1.25	3.00	8.88	15.00	32.00	12.00	10.00	2.88	9.75	3.38	8.88	0.75	12.13	13.88

**DETAILS**

"TOLL" PLAQUE DETAIL DESIGN

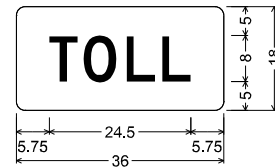

1.50" Radius, 0.00" Border, White on Yellow;  
"TOLL" Black, D 2K;

Table of widths and spaces

T	O	L	L
5.75	4.88	1.13	5.63
1.75	5.00	1.13	5.00
5.75			

STRUCTURE NUMBER		1B0221055L269. 8-000	
LOCATION		92B EXPRESSWAY	
SIZE (W x H)	EXIT PLAQUE	-	
MAIN PANEL		18.5' X 13'	
MOUNTING / TYPE		OVERHEAD / BRIDGE	
MOUNTING LOC (L, M, R)		RIGHT	
SHEETING / COLOR	BACKGROUND	TYPE:	ZZ
		COLOR:	GREEN
		TYPE:	
	LEGEND / BORDER	TYPE:	ZZ
		COLOR:	WHITE
		TYPE:	

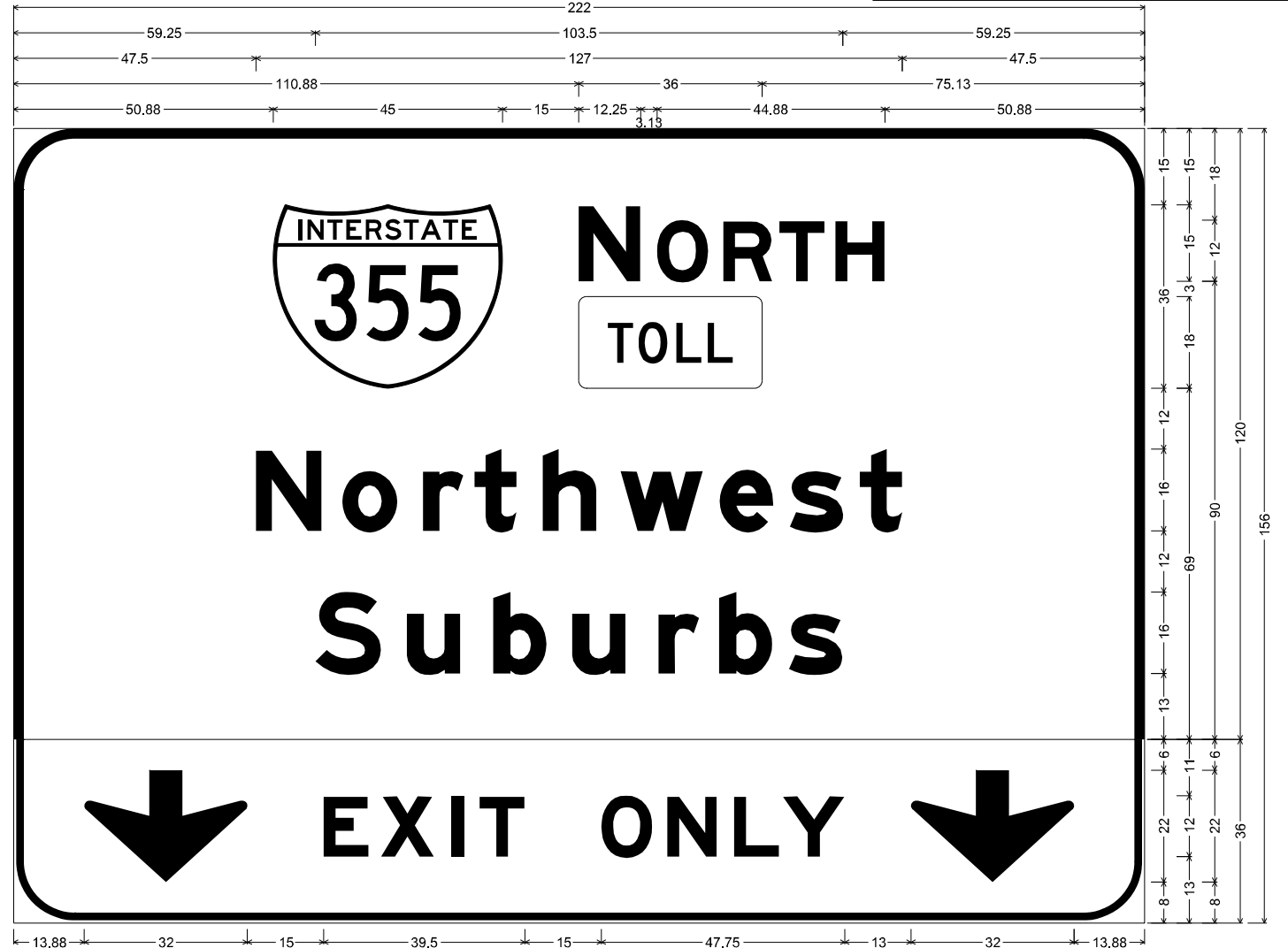

12.00" Radius, 2.00" Border, White on Green;  
"NORTH", E Mod 2K; Rounded Rectangle 1.50" Radius Yellow;  
"Northwest", E Mod 2K; "Suburbs", E Mod 2K;

12.00" Radius, 1.50" Border, 0.50" Indent, Black on Yellow;  
Down Arrow 22.00" 270"; "EXIT", E Mod 2K specified length; "ONLY", E Mod 2K specified length; Down Arrow 22.00" 270";

Table of widths and spaces

50.88	45.00	15.00	12.25	3.13	10.13	2.88	9.75	1.25	8.88	2.25	9.63	51.00								
110.88	36.00	75.13																		
47.50	13.00	4.00	10.88	5.00	8.00	2.00	8.38	5.13	10.50	4.75	16.25	3.25	10.50	3.25	10.50	3.25	8.25	47.63		
59.25	13.00	4.88	10.63	6.38	10.50	5.00	10.50	6.50	8.00	3.75	10.63	3.13	10.63	59.25						
13.88	32.00	15.00	8.88	2.38	10.38	3.50	1.25	3.13	8.88	15.00	10.00	2.88	9.75	3.38	8.88	0.75	12.13	13.00	32.00	13.88

MODEL: D:\p1\... FILE NAME: SW\IP\Design\KKS\Sigs Design\Contract-48546-Sigs-Structure-Design-155-And-1200-County-4-Enc-84-co-Wisner-Rd\006272155\_Signage-IP-KK-CO\BIBREB-06-28-21.com

USER NAME = plascenciaj	DESIGNED - KK	REVISED -
PLOT SCALE = 40,0000 * / in.	DRAWN - KK / IP	REVISED -
PLOT DATE = 7/1/2021	CHECKED - LP	REVISED -
	DATE - 06/25/2021	REVISED -

**STATE OF ILLINOIS  
DEPARTMENT OF TRANSPORTATION**

<b>SIGN PANEL DESIGN</b>			
SCALE:	SHEET	OF SHEETS	STA. TO STA.

F.A.I. RTE.	SECTION	COUNTY	TOTAL SHEETS	SHEET NO.
55	2021-128-SG	VARIOUS	178	142
CONTRACT NO. 62P27				
ILLINOIS FED. AID PROJECT				

STRUCTURE NUMBER		1B022I055L269.8-001	
LOCATION		93 EXPRESSWAY	
SIZE (W x H)	EXIT PLAQUE	-	
	MAIN PANEL	17' X 9'	
MOUNTING / TYPE		OVERHEAD / BRIDGE	
MOUNTING LOC (L, M, R)			
SHEETING / COLOR	BACKGROUND	TYPE:	ZZ
		COLOR:	GREEN
		TYPE:	
	LEGEND / BORDER	COLOR:	
		TYPE:	ZZ
		COLOR:	WHITE

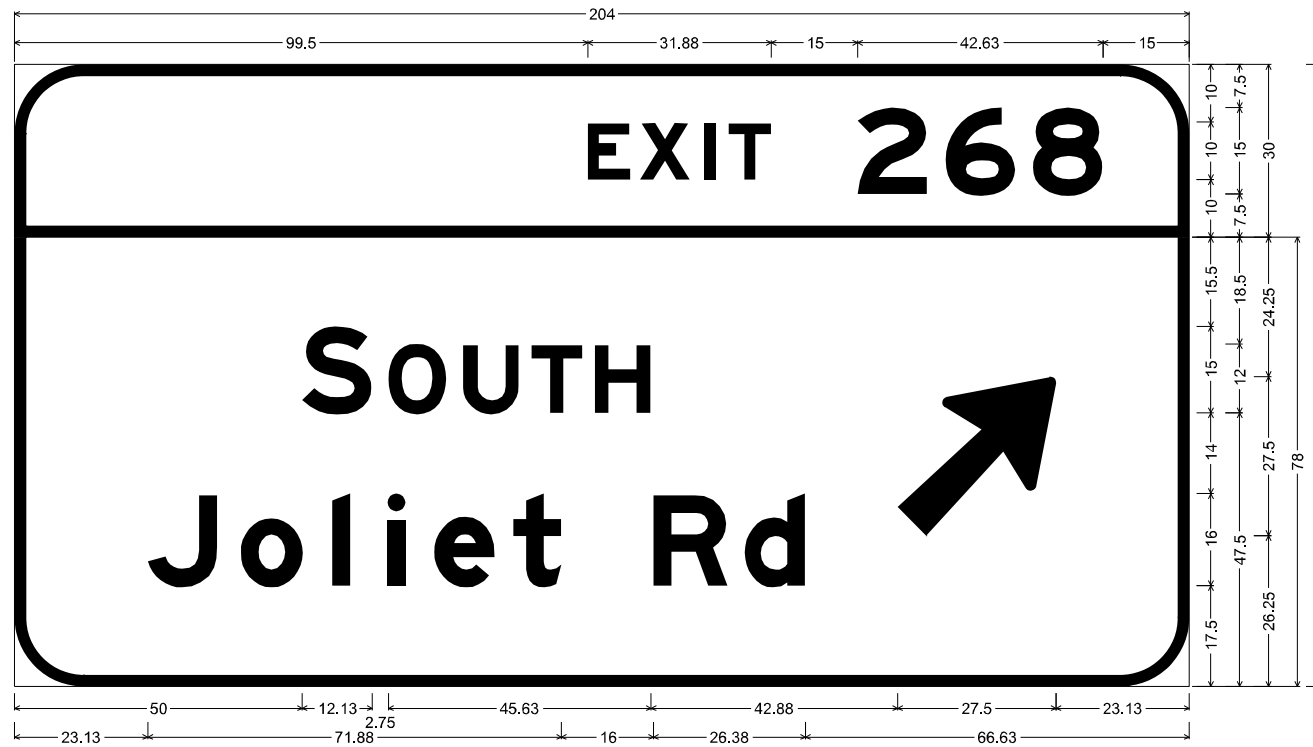

12.00" Radius, 2.00" Border, White on Green;  
 "EXIT", E Mod 2K 120% spacing; "268", E Mod 2K;  
 12.00" Radius, 2.00" Border, White on Green;  
 "SOUTH", E Mod 2K; "Joliet Rd", E Mod 2K; Arrow 160 - 35.00" 45";  
 Table of widths and spaces

99.50	E	7.50	1.63	X	8.75	2.50	I	2.00	2.13	T	7.38	15.00	Z	12.13	3.13	6	12.25	3.00	B	12.13	15.00			
50.00	S	12.13	2.75	O	10.13	2.88	U	9.75	2.13	T	8.88	2.13	H	9.75	42.88	27.50	23.13							
23.13	J	12.13	4.00	O	10.88	5.00	I	3.13	6.50	I	3.13	5.00	e	10.50	3.25	t	8.25	16.00	R	13.00	2.88	d	10.63	66.63

MODEL: D:\p\p\...  
 FILE NAME: S:\p\p\Design\KKS\Signs Design\Contract-46556-Signs-Structure-Design-155-and-1200-County-4-Enc-84-co-Water-Rd\CADD\62P27155\_Signs-IP-KK-COMBINED-06-28-21.dwg

USER NAME = plascencjal	DESIGNED - KK	REVISED -
	DRAWN - KK / IP	REVISED -
PLOT SCALE = 40,0000 * / in.	CHECKED - LP	REVISED -
PLOT DATE = 7/1/2021	DATE - 06/25/2021	REVISED -

**STATE OF ILLINOIS  
DEPARTMENT OF TRANSPORTATION**

**SIGN PANEL DESIGN**

SCALE: SHEET OF SHEETS STA. TO STA.

F.A.I. RTE.	SECTION	COUNTY	TOTAL SHEETS	SHEET NO.
55	2021-128-SG	VARIOUS	178	143
			CONTRACT NO. 62P27	
		ILLINOIS	FED. AID PROJECT	

STRUCTURE NUMBER		1C099I055L268.1-000	
LOCATION		97 EXPRESSWAY	
SIZE (W x H)	EXIT PLAQUE	-	
	MAIN PANEL	15' X 12.5'	
MOUNTING / TYPE		OVERHEAD / CANTILEVER	
MOUNTING LOC (L, M, R)			
SHEETING / COLOR	BACKGROUND	TYPE:	ZZ
		COLOR:	GREEN
		TYPE:	
	LEGEND / BORDER	COLOR:	
		TYPE:	ZZ
		COLOR:	WHITE

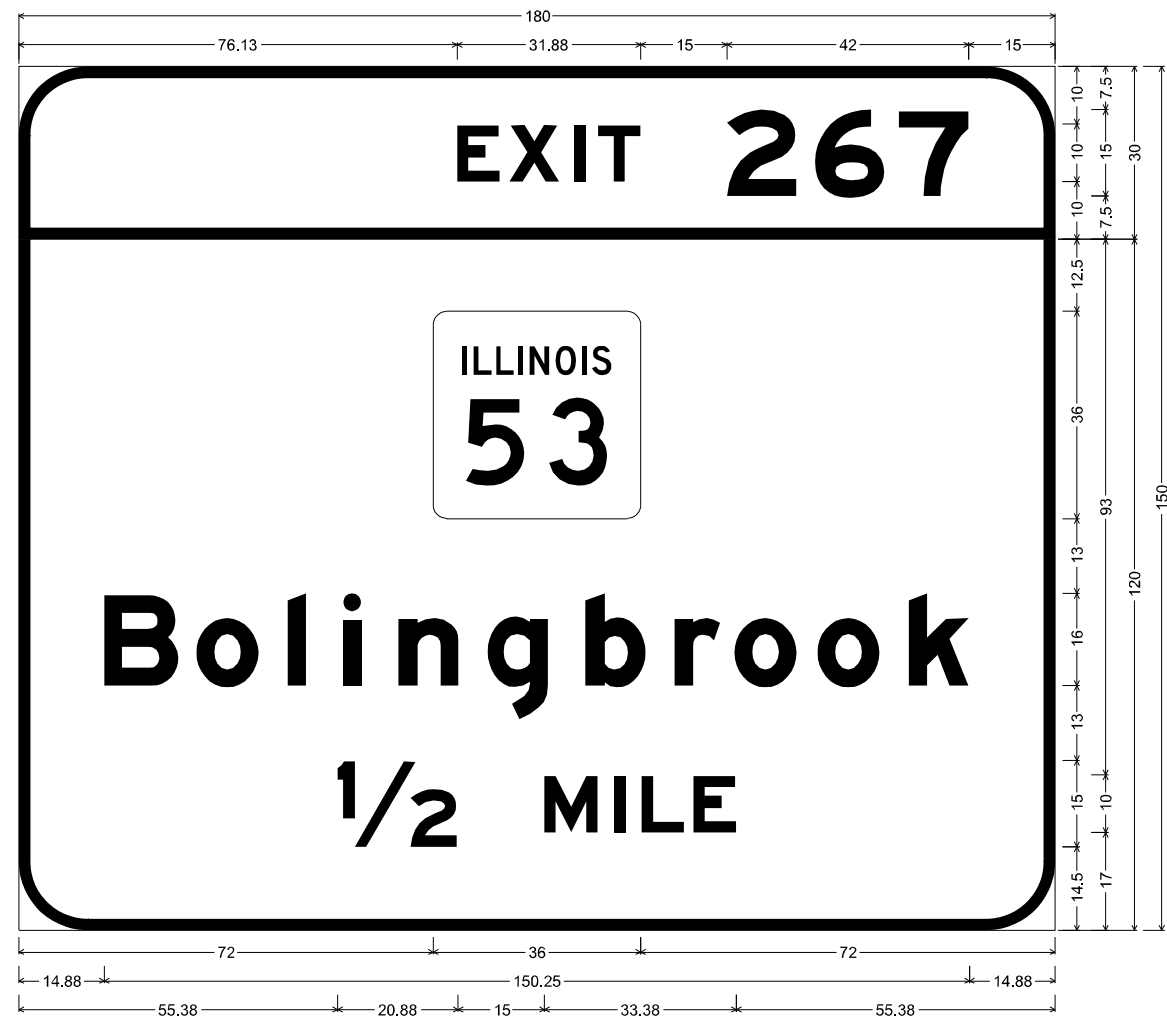

12.00" Radius, 2.00" Border, White on Green;  
 "EXIT", E Mod 2K 120% spacing; "267", E Mod 2K;

12.00" Radius, 2.00" Border, White on Green;  
 "Bolingbrook", E Mod 2K; "1/2 MILE", E Mod 2K;

Table of widths and spaces

76.13	E	7.38	X	1.75	8.63	I	2.50	2.00	2.25	T	7.38	15.00	Z	12.13	3.13	6	12.13	2.50	7	12.13	15.00												
72.00		36.00		72.00																													
14.88	B	13.00	3.00	o	10.88	5.00	i	3.13	6.38	i	3.25	6.38	n	10.63	4.88	g	10.63	6.38	b	10.50	5.00	r	8.00	2.38	o	10.88	3.50	o	10.88	5.00	k	10.50	15.00
55.38	1/2	20.88	15.00	M	9.38	2.75	I	2.00	2.88	L	7.38	1.63	E	7.38	55.38																		

MODEL: D:\p\p\Design\KKS\Signs - Design\Contract-46556-Signs-Structure-Design-155-and-1200-County-4-Enc-84-co-Water-Rd\CADD\62P27-155\_Signs\KKS-IP-KK-COM\BIBED-06-28-21.dwg  
 FILE NAME: Sign\IP\Design\KKS\Signs - Design\Contract-46556-Signs-Structure-Design-155-and-1200-County-4-Enc-84-co-Water-Rd\CADD\62P27-155\_Signs\KKS-IP-KK-COM\BIBED-06-28-21.dwg

USER NAME = plascencjal	DESIGNED - KK	REVISED -
DRAWN - KK / IP	REVISIONS	
PLOT SCALE = 40,0000 * / in.	CHECKED - LP	REVISED -
PLOT DATE = 7/1/2021	DATE - 06/25/2021	REVISED -

**STATE OF ILLINOIS**  
**DEPARTMENT OF TRANSPORTATION**

<b>SIGN PANEL DESIGN</b>			
SCALE:	SHEET	OF	SHEETS
	STA.		TO STA.

F.A.I. RTE.	SECTION	COUNTY	TOTAL SHEETS	SHEET NO.
55	2021-128-SG	VARIOUS	178	144
			CONTRACT NO. 62P27	
		ILLINOIS	FED. AID PROJECT	

STRUCTURE NUMBER		1S0991055L268.0-000	
LOCATION		98A	EXPRESSWAY
SIZE (W x H)	EXIT PLAQUE	-	
	MAIN PANEL	10.5' X 8'	
MOUNTING / TYPE		OVERHEAD / TRUSS	
MOUNTING LOC (L, M, R)		LEFT	
SHEETING / COLOR	BACKGROUND	TYPE:	ZZ
		COLOR:	GREEN
		TYPE:	
	LEGEND / BORDER	TYPE:	ZZ
		COLOR:	WHITE
		TYPE:	
		COLOR:	

STRUCTURE NUMBER		1S0991055L268.0-000	
LOCATION		98B	EXPRESSWAY
SIZE (W x H)	EXIT PLAQUE	-	
	MAIN PANEL	15' X 13'	
MOUNTING / TYPE		OVERHEAD / TRUSS	
MOUNTING LOC (L, M, R)		RIGHT	
SHEETING / COLOR	BACKGROUND	TYPE:	ZZ
		COLOR:	GREEN
		TYPE:	
	LEGEND / BORDER	TYPE:	ZZ
		COLOR:	WHITE
		TYPE:	
		COLOR:	

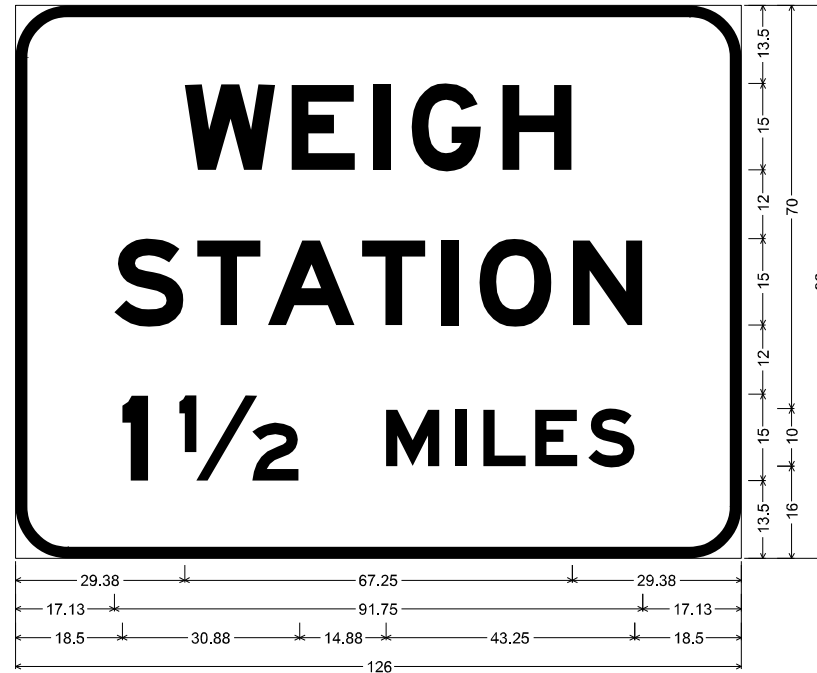

9.00" Radius, 2.00" Border, White on Green;  
 "WEIGH", E Mod 2K; "STATION", E Mod 2K; "1 1/2 MILES", E Mod 2K;

Table of widths and spaces

29.38	W	15.88	2.63	E	11.13	3.13	I	3.00	3.63	G	12.13	3.63	H	12.13	29.38						
17.13	S	12.13	2.25	T	11.13	1.13	A	15.13	1.25	T	11.13	2.63	I	3.00	3.63	O	12.63	3.63	N	12.13	17.13
18.50	I	4.50	5.38	1/2	20.88	15.00	M	9.38	2.75	I	2.00	2.88	L	7.38	1.50	E	7.50	1.75	S	8.13	18.50

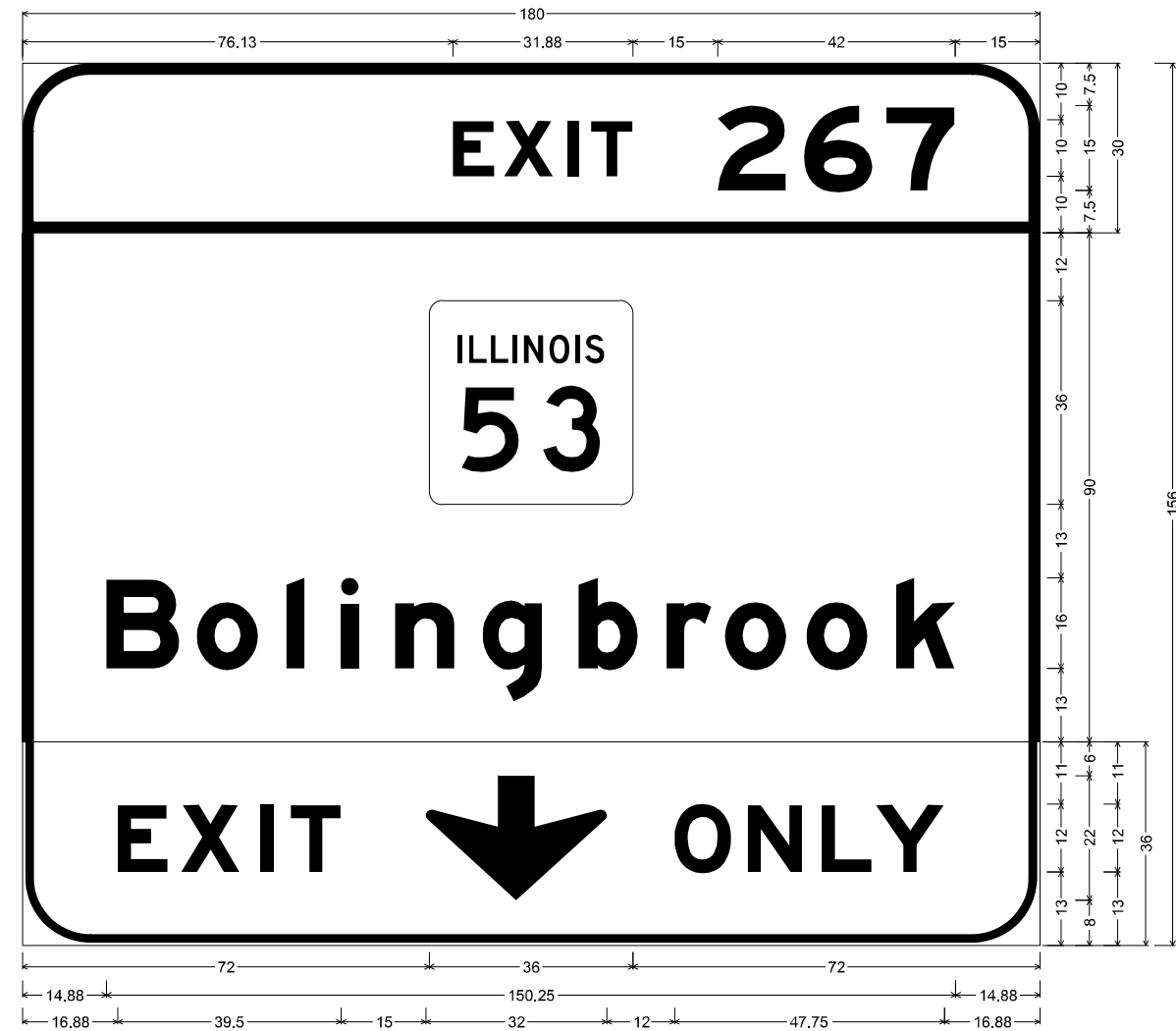

12.00" Radius, 2.00" Border, White on Green;  
 "EXIT", E Mod 2K 120% spacing; "267", E Mod 2K;

12.00" Radius, 2.00" Border, White on Green;  
 "Bolingbrook", E Mod 2K;

12.00" Radius, 1.50" Border, 0.50" Indent, Black on Yellow;  
 "EXIT", E Mod 2K 140% spacing; Down Arrow 22.00" 270"; "ONLY", E Mod 2K;

Table of widths and spaces

76.13	E	7.38	1.75	X	8.63	2.50	I	2.00	2.25	T	7.38	15.00	2	12.13	3.13	6	12.13	2.50	7	12.13	15.00											
72.00		36.00	72.00																													
14.88	B	13.00	3.00	O	10.88	5.00	I	3.13	6.38	3.25	6.38	n	10.63	4.88	g	10.63	6.38	b	10.50	5.00	r	8.00	2.38	O	10.88	3.50	O	10.88	5.00	k	10.50	15.00
16.88	E	8.88	2.38	X	10.38	3.50	I	2.50	3.00	T	8.88	15.00	32.00	12.00	O	10.00	2.88	N	9.75	3.38	L	8.88	0.75	Y	12.13	16.88						

MODEL: D:\p\p\Design\KKS\Signs - Design\Contract-48546-Signs-Structure-Design-155-and-1200-County-4-Enc-84-co-Water-80-CDD\62P27-155\_Signs-IP-KK-CO\BIBED-06-28-21.com

USER NAME = plascencia	DESIGNED - KK	REVISED -
DRAWN - KK / IP	REVISIONS -	
PLOT SCALE = 40,0000 * / in.	CHECKED - LP	REVISED -
PLOT DATE = 7/1/2021	DATE - 06/25/2021	REVISED -

STATE OF ILLINOIS  
DEPARTMENT OF TRANSPORTATION

SIGN PANEL DESIGN

SCALE: SHEET OF SHEETS STA. TO STA.

F.A.I. RTE.	SECTION	COUNTY	TOTAL SHEETS	SHEET NO.
55	2021-128-SG	VARIOUS	178	145
				CONTRACT NO. 62P27
		ILLINOIS	FED. AID PROJECT	

STRUCTURE NUMBER		1C0991055L267.7-000	
LOCATION		99 EXPRESSWAY	
SIZE (W x H)	EXIT PLAQUE	-	
	MAIN PANEL	18.5' X 13'	
MOUNTING / TYPE		OVERHEAD / CANTILEVER	
MOUNTING LOC (L, M, R)			
SHEETING / COLOR	BACKGROUND	TYPE:	ZZ
		COLOR:	GREEN
		TYPE:	
		COLOR:	
	LEGEND / BORDER	TYPE:	ZZ
		COLOR:	WHITE
		TYPE:	
		COLOR:	

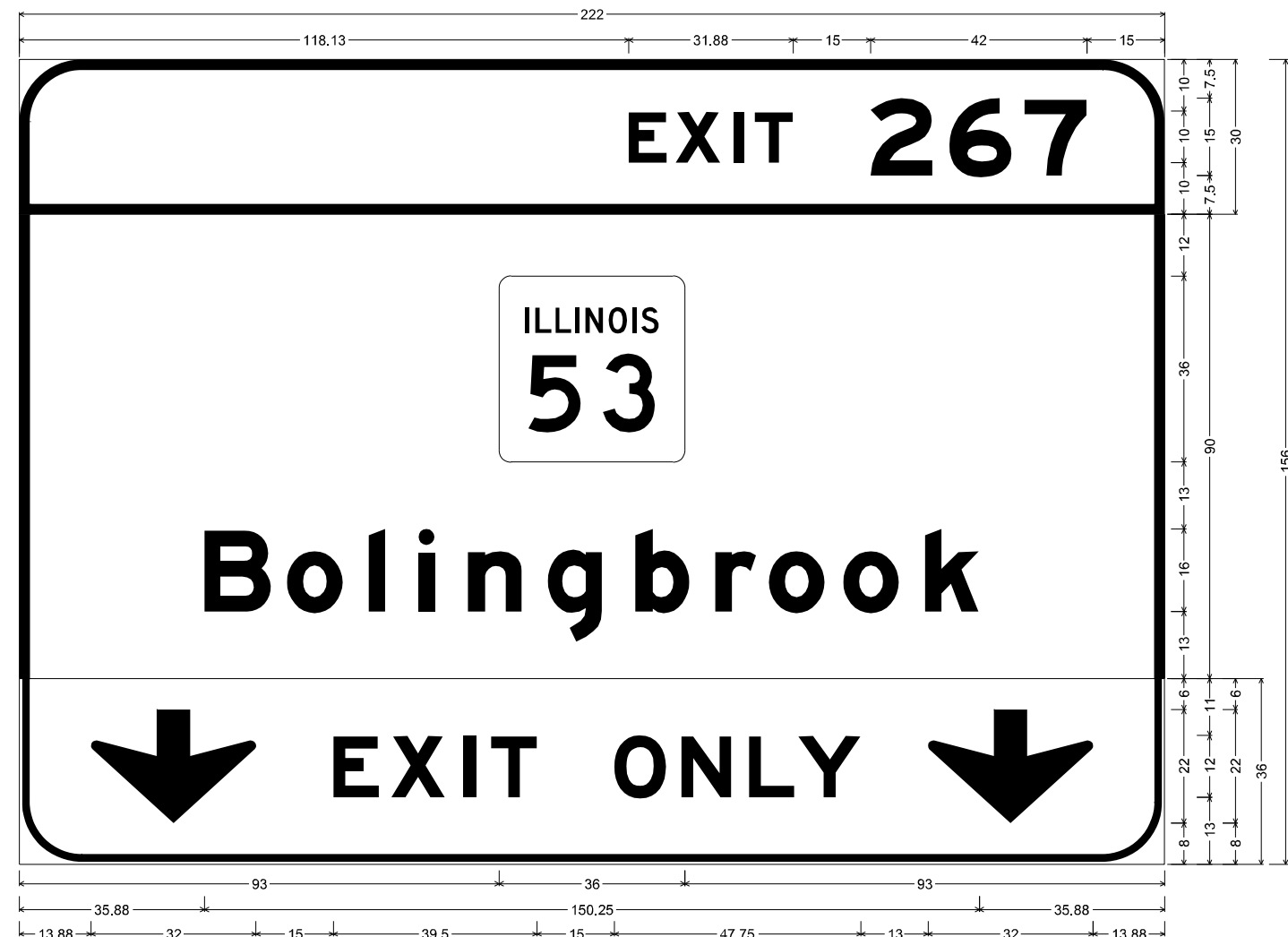

12.00" Radius, 2.00" Border, White on Green;  
 "EXIT", E Mod 2K 120% spacing; "267", E Mod 2K;

12.00" Radius, 2.00" Border, White on Green;  
 "Bolingbrook", E Mod 2K;

12.00" Radius, 1.50" Border, 0.50" Indent, Black on Yellow;  
 Down Arrow 22.00" 270°; "EXIT", E Mod 2K specified length; "ONLY", E Mod 2K specified length; Down Arrow 22.00" 270°;

Table of widths and spaces

118.13	E	7.38	1.75	X	8.63	2.50	I	2.00	2.25	T	7.38	15.00	2	12.13	3.13	6	12.13	2.50	7	12.13	15.00										
93.00	53	36.00	93.00																												
35.88	B	13.00	3.00	o	10.88	5.00	i	3.13	6.38	3.25	6.38	10.63	4.88	g	10.63	6.38	b	10.50	5.00	r	8.00	2.38	o	10.88	3.50	o	10.88	5.00	k	10.50	36.00
13.88	32.00	15.00	E	8.88	2.38	X	10.38	3.50	I	2.38	3.13	T	8.88	15.00	O	10.00	2.88	N	9.75	3.38	L	8.88	0.75	Y	12.13	13.00	32.00	13.88			

MODEL: D:\p\p\Design\KKS\Signs - Design\Contract-46556-Signs-Structure-Design-155-and-1200-County-4-Enc-84-co-Water-Rd\CADD\62P27-155\_Signs\KKS-IP-KK-COM\BIBED-06-28-21.dwg  
 FILE NAME: Sign\IP\Design\KKS\Signs - Design\Contract-46556-Signs-Structure-Design-155-and-1200-County-4-Enc-84-co-Water-Rd\CADD\62P27-155\_Signs\KKS-IP-KK-COM\BIBED-06-28-21.dwg

USER NAME = plascencjal DRAWN - KK / IP PLOT SCALE = 40,0000 * / in. PLOT DATE = 7/1/2021	DESIGNED - KK DRAWN - KK / IP CHECKED - LP DATE - 06/25/2021	REVISED - REVISED - REVISED - REVISED -	<b>STATE OF ILLINOIS</b> <b>DEPARTMENT OF TRANSPORTATION</b>	<b>SIGN PANEL DESIGN</b>		F.A.I. RTE.	SECTION	COUNTY	TOTAL SHEETS	SHEET NO.
						55	2021-128-SG	VARIOUS	178	146
						SCALE:		SHEET OF SHEETS		STA. TO STA.
						ILLINOIS		FED. AID PROJECT		CONTRACT NO. 62P27

STRUCTURE NUMBER		1C0991055L265.9-000	
LOCATION		100 EXPRESSWAY	
SIZE (W x H)	EXIT PLAQUE	-	
	MAIN PANEL	13' X 5.5'	
MOUNTING / TYPE		OVERHEAD / CANTILEVER	
MOUNTING LOC (L, M, R)			
SHEETING / COLOR	BACKGROUND	TYPE:	ZZ
		COLOR:	GREEN
		TYPE:	
	LEGEND / BORDER	COLOR:	
		TYPE:	ZZ
		COLOR:	WHITE

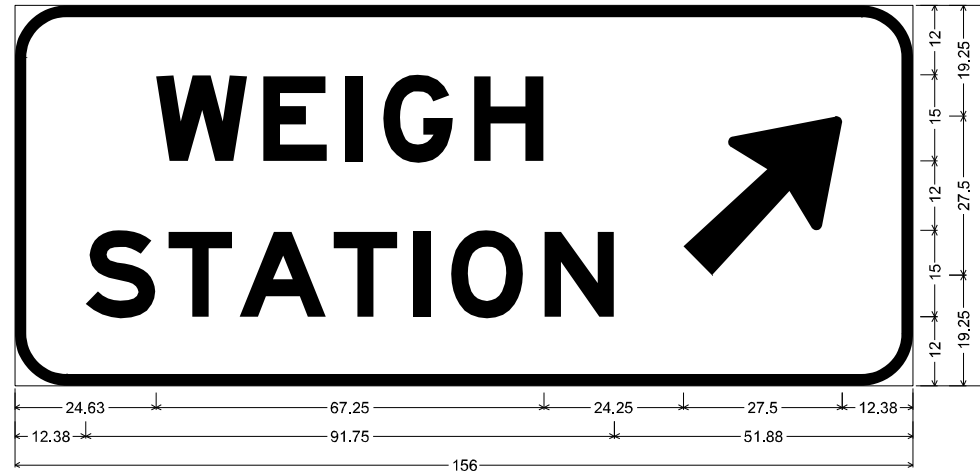

9.00" Radius, 2.00" Border, White on Green;  
 "WEIGH", E Mod 2K; "STATION", E Mod 2K; Arrow 160 - 35.00" 45";

Table of widths and spaces

24.63	W	15.88	2.63	E	11.13	3.13	I	3.00	3.63	G	12.13	3.63	H	12.13	24.25	↗	27.50	12.38			
12.38	S	12.13	2.25	T	11.13	1.13	A	15.13	1.25	T	11.13	2.63	I	3.00	3.63	O	12.63	3.63	N	12.13	51.88

MODEL: D:\p\h  
 FILE NAME: S:\IP\Design\KKS\Signs Design\Contract-48556\Sign-Structure-Design-155\_and-1200-County-4-Enc-84-co-Water-Rd\CADD\62P27-155\_Signs-IP-KK-COMBINED-06-28-21.dwg

USER NAME = plascencjal	DESIGNED - KK	REVISED -
DRAWN - KK / IP	REVISIONS -	
PLOT SCALE = 40,0000 * / in.	CHECKED - LP	REVISED -
PLOT DATE = 7/1/2021	DATE - 06/25/2021	REVISED -

**STATE OF ILLINOIS  
DEPARTMENT OF TRANSPORTATION**

**SIGN PANEL DESIGN**

SCALE: SHEET OF SHEETS STA. TO STA.

F.A.I. RTE.	SECTION	COUNTY	TOTAL SHEETS	SHEET NO.
55	2021-128-SG	VARIOUS	178	147
CONTRACT NO. 62P27			ILLINOIS FED. AID PROJECT	

STRUCTURE NUMBER		1C0991055L264.7-000	
LOCATION		101	EXPRESSWAY
SIZE (W x H)	EXIT PLAQUE	-	
	MAIN PANEL	12' X 8.5'	
MOUNTING / TYPE		OVERHEAD / CANTILEVER	
MOUNTING LOC (L, M, R)			
SHEETING / COLOR	BACKGROUND	TYPE:	ZZ
		COLOR:	GREEN
		TYPE:	
	LEGEND / BORDER	COLOR:	
		TYPE:	ZZ
		COLOR:	WHITE

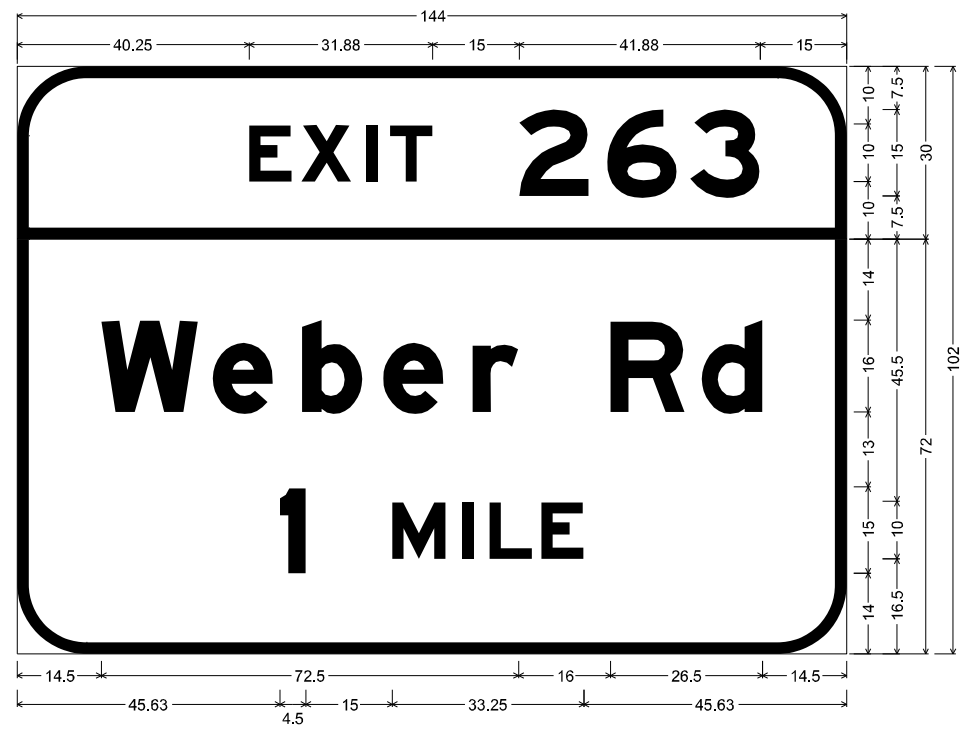

12.00" Radius, 2.00" Border, White on Green;  
 "EXIT", E Mod 2K 120% spacing; "263", E Mod 2K;

12.00" Radius, 2.00" Border, White on Green;  
 "Weber Rd", E Mod 2K; "1 MILE", E Mod 2K;

Table of widths and spaces

40.25	<b>E</b>	7.50	<b>X</b>	1.63	8.75	2.50	<b>I</b>	2.00	2.13	7.38	15.00	<b>2</b>	12.13	3.13	<b>6</b>	12.25	2.25	<b>3</b>	12.13	15.00	
14.50	<b>W</b>	17.00	2.38	<b>e</b>	10.63	4.88	<b>b</b>	10.63	3.50	<b>e</b>	10.50	5.00	<b>r</b>	8.00	16.00	<b>R</b>	13.00	2.88	<b>d</b>	10.50	14.63
45.63	<b>I</b>	4.50	15.00	<b>M</b>	9.25	2.88	<b>I</b>	2.00	2.75	<b>L</b>	7.38	1.63	<b>E</b>	7.38	45.63						

MODEL: D:\p\p\Design\KKS\Signs Design\Contract-46556\Signs\Structure\Design-155\and-1200\County\Hinc\464\Weber-Rd\CADD\62P27-155\_Signs\IP-KK-COMBINED-06-28-21.dwg  
 FILE NAME: Sign\IP\Design\KKS\Signs Design\Contract-46556\Signs\Structure\Design-155\and-1200\County\Hinc\464\Weber-Rd\CADD\62P27-155\_Signs\IP-KK-COMBINED-06-28-21.dwg

USER NAME = plascencjal	DESIGNED - KK	REVISED -
	DRAWN - KK / IP	REVISED -
PLOT SCALE = 40,0000 * / in.	CHECKED - LP	REVISED -
PLOT DATE = 7/1/2021	DATE - 06/25/2021	REVISED -

**STATE OF ILLINOIS  
DEPARTMENT OF TRANSPORTATION**

<b>SIGN PANEL DESIGN</b>			
SCALE:	SHEET	OF	SHEETS
	STA.		TO STA.

F.A.I. RTE.	SECTION	COUNTY	TOTAL SHEETS	SHEET NO.
55	2021-128-5G	VARIOUS	178	148
			CONTRACT NO. 62P27	
		ILLINOIS	FED. AID PROJECT	



STRUCTURE NUMBER		1C0991055L264.2-000	
LOCATION		102 EXPRESSWAY	
SIZE (W x H)	EXIT PLAQUE	-	
	MAIN PANEL	12' X 8.5'	
MOUNTING / TYPE		OVERHEAD / CANTILEVER	
MOUNTING LOC (L, M, R)			
SHEETING / COLOR	BACKGROUND	TYPE:	ZZ
		COLOR:	GREEN
		TYPE:	
	LEGEND / BORDER	COLOR:	
		TYPE:	ZZ
		COLOR:	WHITE

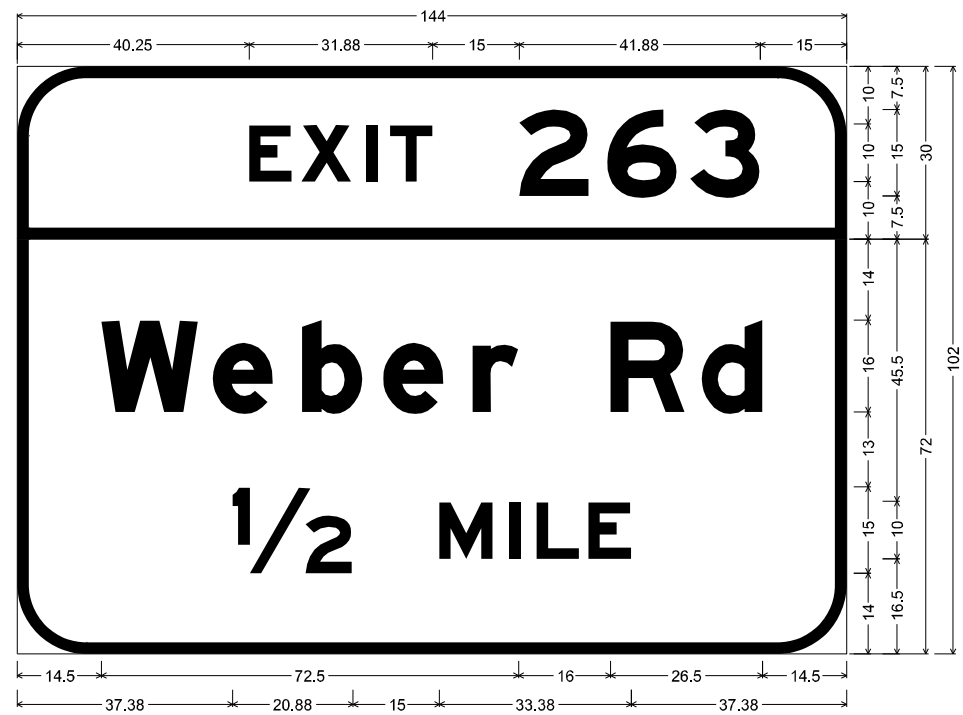

12.00" Radius, 2.00" Border, White on Green;  
 "EXIT", E Mod 2K 120% spacing; "263", E Mod 2K;  
 12.00" Radius, 2.00" Border, White on Green;  
 "Weber Rd", E Mod 2K; "1/2 MILE", E Mod 2K;

Table of widths and spaces

40.25	<b>E</b>	7.50	<b>X</b>	1.63	8.75	<b>I</b>	2.50	2.00	2.13	<b>T</b>	7.38	15.00	<b>2</b>	12.13	3.13	<b>6</b>	12.25	2.25	<b>3</b>	12.13	15.00
14.50	<b>W</b>	17.00	<b>e</b>	2.38	10.63	<b>b</b>	4.88	10.63	3.50	<b>e</b>	10.50	5.00	<b>r</b>	8.00	16.00	<b>R</b>	13.00	2.88	<b>d</b>	10.50	14.63
37.38	1/2	20.88	<b>M</b>	15.00	9.38	<b>I</b>	2.75	2.00	2.88	<b>L</b>	7.38	1.63	<b>E</b>	7.38	37.38						

MODEL: D:\p\p\Design\KKS\Signs\_Design\Contract-46556\Signs\_Structure\Design-155\_and-1200\County\Weber-Rd\CADD\62P27-155\_Signs\KKS-IP-KK-COMBINED-06-28-21.dwg  
 FILE NAME: Sign\IP\Design\KKS\Signs\_Design\Contract-46556\Signs\_Structure\Design-155\_and-1200\County\Weber-Rd\CADD\62P27-155\_Signs\KKS-IP-KK-COMBINED-06-28-21.dwg

USER NAME = plascencjal	DESIGNED - KK	REVISED -
PLOT SCALE = 40,0000 * / in.	DRAWN - KK / IP	REVISED -
PLOT DATE = 7/1/2021	CHECKED - LP	REVISED -
	DATE - 06/25/2021	REVISED -

**STATE OF ILLINOIS**  
**DEPARTMENT OF TRANSPORTATION**

<b>SIGN PANEL DESIGN</b>			
SCALE:	SHEET	OF	SHEETS
	STA.		TO STA.

F.A.I. RTE.	SECTION	COUNTY	TOTAL SHEETS	SHEET NO.
55	2021-128-5G	VARIOUS	178	149
CONTRACT NO. 62P27				
ILLINOIS FED. AID PROJECT				

STRUCTURE NUMBER		1G016I055L276.3-000	
LOCATION		104A EXPRESSWAY	
SIZE (W x H)	EXIT PLAQUE	-	
	MAIN PANEL	23' x 8.5'	
MOUNTING / TYPE		GROUND	
MOUNTING LOC (L, M, R)		RIGHT	
SHEETING / COLOR	BACKGROUND	TYPE:	ZZ
		COLOR:	GREEN
		TYPE:	
	LEGEND / BORDER	COLOR:	
		TYPE:	ZZ
		COLOR:	WHITE

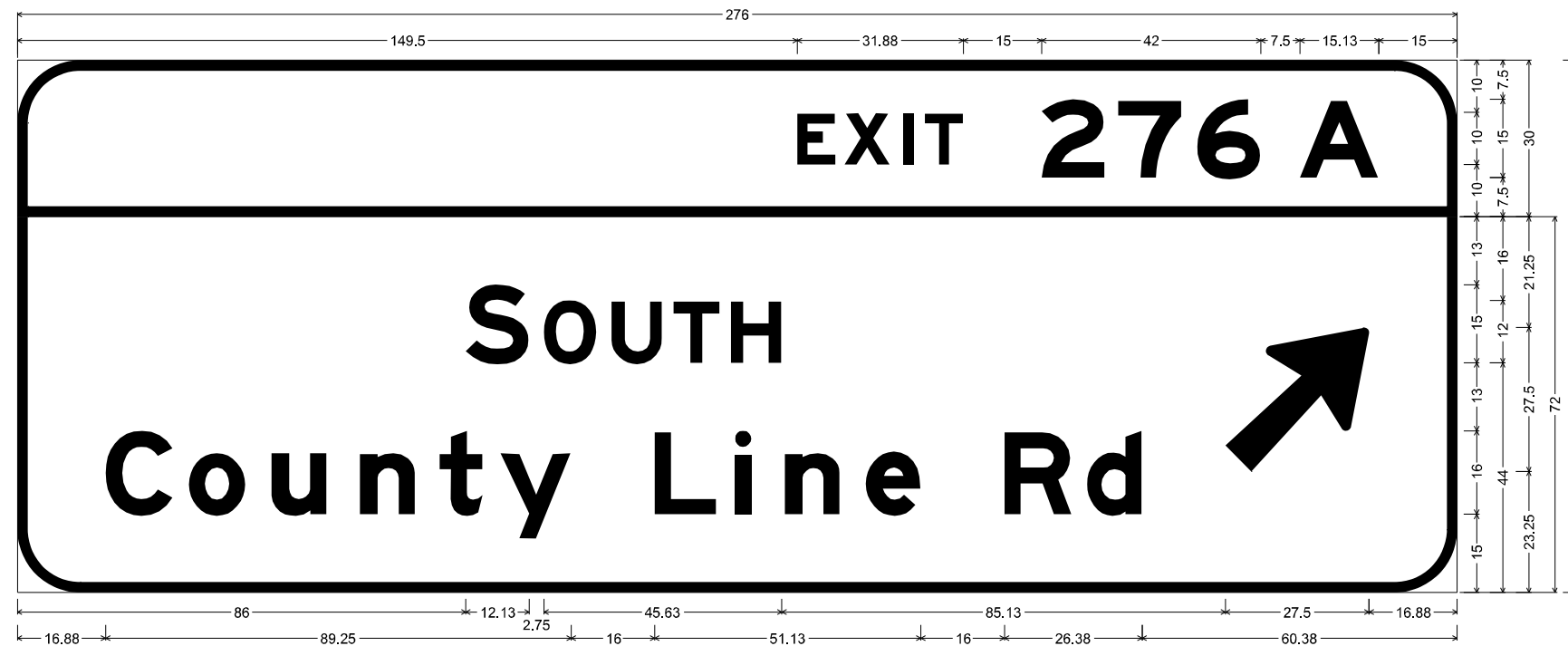

12.00" Radius, 2.00" Border, White on Green;  
 "EXIT", E Mod 2K 120% spacing; "276", E Mod 2K; "A", E Mod 2K;  
 12.00" Radius, 2.00" Border, White on Green;  
 "SOUTH", E Mod 2K; "County Line Rd", E Mod 2K; Arrow 160 - 35.00" 45°;  
 Table of widths and spaces

149.50	E	7.38	1.75	X	8.63	2.50	I	2.00	2.25	T	7.38	15.00	Z	12.13	2.50	7	12.13	3.00	6	12.25	7.50	A	15.13	15.00												
86.00	S	12.13	2.75	O	10.13	2.88	U	9.75	2.13	T	8.88	2.13	H	9.75	85.13	27.50	16.88																			
16.88	C	13.00	3.00	O	10.88	5.00	U	10.50	6.38	n	10.63	4.63	t	8.25	3.38	y	13.63	16.00	L	11.88	3.50	i	3.13	6.50	n	10.50	5.00	e	10.50	16.00	R	13.00	2.88	d	10.50	60.50

MODEL: D:\p\h  
 FILE NAME: S:\IP\Design\KKS\Signs Design\Contract-48556-Signs-Structure-Design-155-and-1200-County-Line-Rd-co-Water-Rd\CADD\62P27-155\_Signs-IP-KK-COMBINED-06-28-21.dwg

USER NAME = plascenciaj	DESIGNED - KK	REVISED -
DRAWN - KK / IP	REVISIONS -	
PLOT SCALE = 40,0000 * / in.	CHECKED - LP	REVISED -
PLOT DATE = 7/1/2021	DATE - 06/25/2021	REVISED -

**STATE OF ILLINOIS  
DEPARTMENT OF TRANSPORTATION**

**SIGN PANEL DESIGN**

SCALE: SHEET OF SHEETS STA. TO STA.

F.A.I. RTE.	SECTION	COUNTY	TOTAL SHEETS	SHEET NO.
55	2021-128-SG	VARIOUS	178	150
CONTRACT NO. 62P27			ILLINOIS FED. AID PROJECT	

STRUCTURE NUMBER		1G022I055L275.4-000	
LOCATION		105 EXPRESSWAY	
SIZE (W x H)	EXIT PLAQUE	-	
	MAIN PANEL	15.5' X 12.5'	
MOUNTING / TYPE		GROUND	
MOUNTING LOC (L, M, R)		RIGHT	
SHEETING / COLOR	BACKGROUND	TYPE:	ZZ
		COLOR:	GREEN
		TYPE:	
	LEGEND / BORDER	COLOR:	
		TYPE:	ZZ
		COLOR:	WHITE

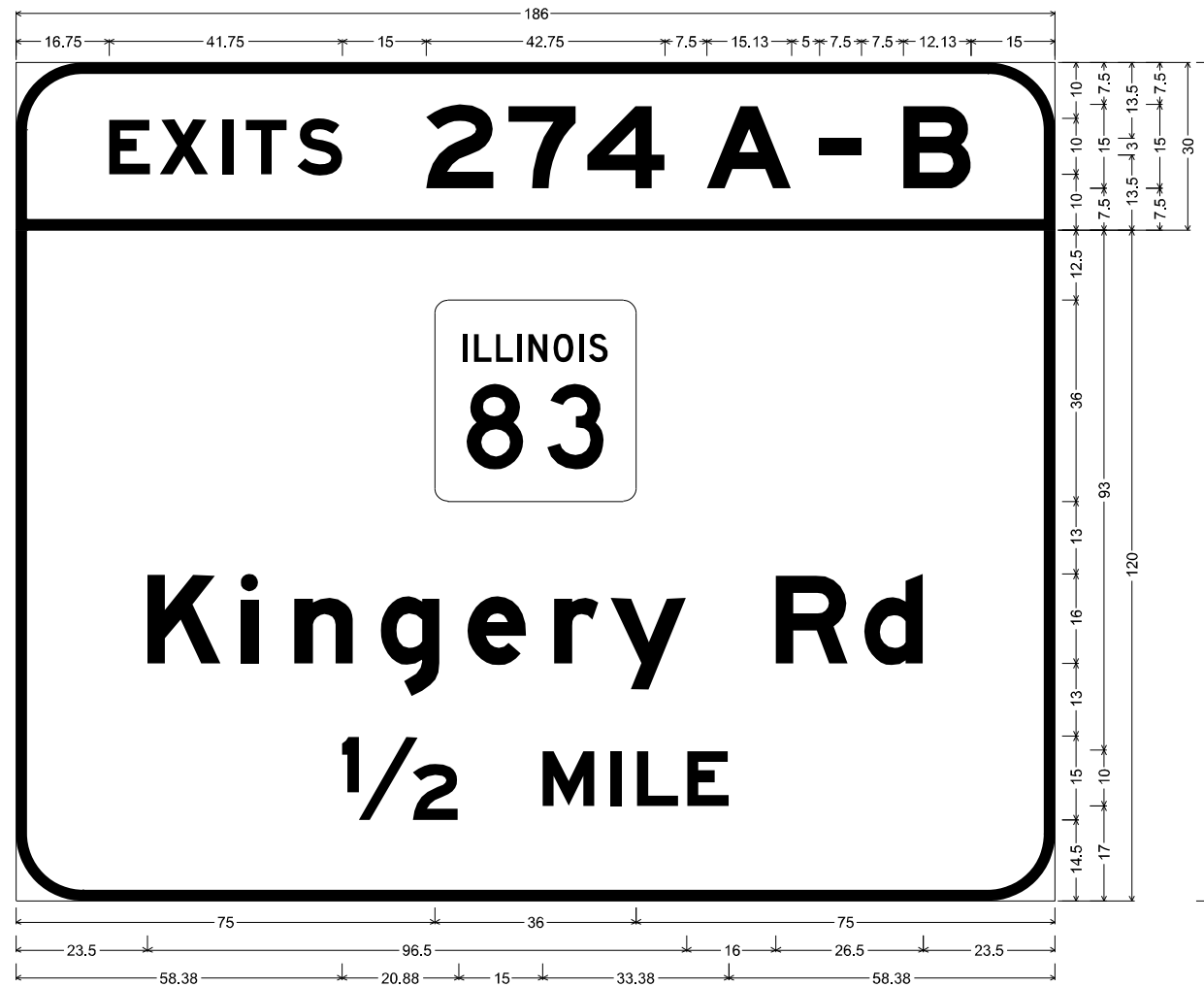

12.00" Radius, 2.00" Border, White on Green;  
 "EXITS", E Mod 2K 120% spacing; "274", E Mod 2K; "A", E Mod 2K; "B", E Mod 2K;

12.00" Radius, 2.00" Border, White on Green;  
 "Kingery Rd", E Mod 2K; "1/2 MILE", E Mod 2K;

Table of widths and spaces

16.75	E	7.38	X	1.63	8.75	I	2.50	2.00	2.13	T	7.38	1.88	8.00	S	15.00	Z	12.25	2.50	7	12.13	2.00	4	13.88	7.50	A	15.25	5.00	□	7.50	7.50	B	12.13	15.00
75.00	36.00		75.00																														
23.50	K	13.13	3.63	i	3.13	6.38	n	10.63	4.88	g	10.63	4.88	e	10.63	5.00	r	8.00	2.00	y	13.63	16.00	R	13.00	2.88	d	10.50	23.63						
58.38	1/2	20.88	15.00	M	9.38	2.75	I	2.00	2.88	L	7.38	1.63	E	7.38	58.38																		

MODEL: D:\p\h  
 FILE NAME: S:\IP\Design\KKS\Signs - Design\Contract-48556-Signs-Structure-Design-155-and-1200-County-4-Enc-84-co-Water-Rd\CADD\62P27155\_Signs-IP-KK-COMBINED-06-28-21.dwg  
 DATE: 7/1/2021

USER NAME = plascencjal	DESIGNED - KK	REVISED -
DRAWN - KK / IP	REVISOR -	
PLOT SCALE = 40,0000 * / in.	CHECKED - LP	REVISOR -
PLOT DATE = 7/1/2021	DATE - 06/25/2021	REVISOR -

**STATE OF ILLINOIS  
DEPARTMENT OF TRANSPORTATION**

**SIGN PANEL DESIGN**

SCALE: SHEET OF SHEETS STA. TO STA.

F.A.I. RTE.	SECTION	COUNTY	TOTAL SHEETS	SHEET NO.
55	2021-128-SG	VARIOUS	178	151
CONTRACT NO. 62P27			ILLINOIS FED. AID PROJECT	

STRUCTURE NUMBER		1G022I055L274.0-001	
LOCATION		106 EXPRESSWAY	
SIZE (W x H)	EXIT PLAQUE	-	
	MAIN PANEL	14.5' X 10.5'	
MOUNTING / TYPE		GROUND	
MOUNTING LOC (L, M, R)		RIGHT	
SHEETING / COLOR	BACKGROUND	TYPE:	ZZ
		COLOR:	GREEN
		TYPE:	
		COLOR:	
	LEGEND / BORDER	TYPE:	ZZ
		COLOR:	WHITE
		TYPE:	
		COLOR:	



12.00" Radius, 2.00" Border, White on Green;  
 "Darrien", E Mod 2K; "Argonne Nat'l", E Mod 2K; "Laboratory", E Mod 2K; "EXIT 273A", E Mod 2K;  
 Table of widths and spaces

53.88	D	10.88	2.75	a	8.88	5.25	r	6.75	3.13	i	2.63	4.13	e	8.88	4.13	n	8.75	54.00												
2.00	170.00		2.00																											
14.50	A	13.38	3.25	r	6.63	2.00	g	8.88	4.13	o	9.00	4.13	n	8.88	5.25	n	8.88	4.13	e	8.75										
	N	13.38	10.75	3.38	a	8.75	3.88	t	6.88	2.25	2.63	3.13	l	2.75	14.38															
29.50	L	9.88	1.75	a	8.75	5.38	b	8.75	3.00	o	9.00	4.25	r	6.63	2.00	a	8.75	3.88	t	7.00	3.00	o	9.13	4.13	r	6.63	1.75	y	11.25	29.63
34.88	E	7.38	1.38	x	8.75	2.00	i	2.00	1.88	T	7.38	15.00	2	12.13	2.63	7	12.13	2.25	3	12.13	2.13	A	15.13	34.88						

MODEL: D:\p\p\Design\KKS\Signs\_Design\Contract-46556-Signs\_Structure-Design-155-and-1200-County-4-Enc-84-co-Water-Rd\CADD\62P27-155\_Signs\KKS-IP-KK-COM\BIBED-06-28-21.dwg  
 FILE NAME: S:\IP\Design\KKS\Signs\_Design\Contract-46556-Signs\_Structure-Design-155-and-1200-County-4-Enc-84-co-Water-Rd\CADD\62P27-155\_Signs\KKS-IP-KK-COM\BIBED-06-28-21.dwg

USER NAME = plascencjal	DESIGNED - KK	REVISED -
DRAWN - KK / IP	REVISIONS -	
PLOT SCALE = 40,0000 * / in.	CHECKED - LP	REVISED -
PLOT DATE = 7/1/2021	DATE - 06/25/2021	REVISED -

**STATE OF ILLINOIS**  
**DEPARTMENT OF TRANSPORTATION**

<b>SIGN PANEL DESIGN</b>			
SCALE:	SHEET	OF	SHEETS
STA.	TO	STA.	

F.A.I. RTE.	SECTION	COUNTY	TOTAL SHEETS	SHEET NO.
55	2021-128-SG	VARIOUS	178	152
CONTRACT NO. 62P27			ILLINOIS FED. AID PROJECT	

STRUCTURE NUMBER		1G0221055L273.5-000	
LOCATION		107 EXPRESSWAY	
SIZE (W x H)	EXIT PLAQUE	-	
	MAIN PANEL	13' X 11'	
MOUNTING / TYPE		GROUND	
MOUNTING LOC (L, M, R)		RIGHT	
SHEETING / COLOR	BACKGROUND	TYPE:	ZZ
		COLOR:	GREEN
		TYPE:	
		COLOR:	
	LEGEND / BORDER	TYPE:	ZZ
		COLOR:	WHITE
		TYPE:	
		COLOR:	

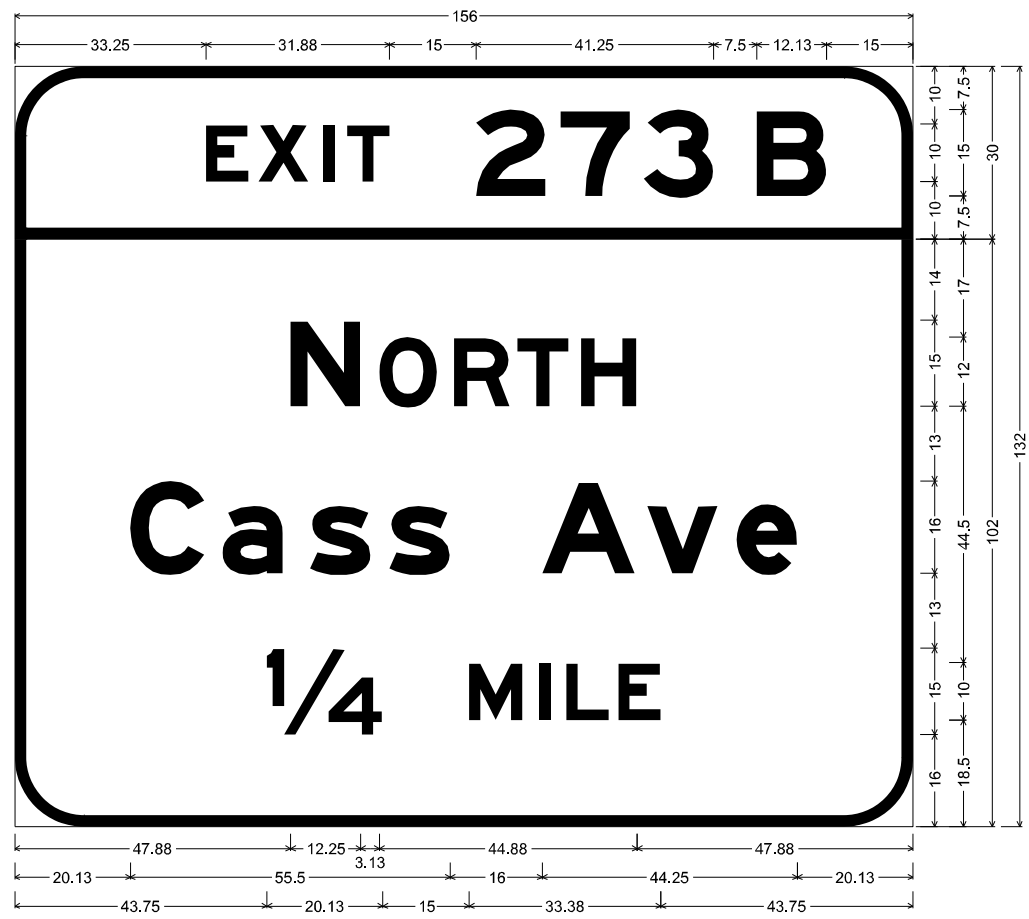

12.00" Radius, 2.00" Border, White on Green;  
"EXIT", E Mod 2K 120% spacing; "273", E Mod 2K; "B", E Mod 2K;  
12.00" Radius, 2.00" Border, White on Green;  
"NORTH", E Mod 2K; "Cass Ave", E Mod 2K; "1/4 MILE", E Mod 2K;  
Table of widths and spaces

33.25	E	7.38	1.75	X	8.63	2.50	I	2.00	2.25	T	7.38	15.00	2	12.13	2.50	7	12.13	2.25	3	12.25	7.50	B	12.13	15.00
47.88	N	12.25	3.13	O	10.13	2.88	R	9.75	1.25	T	8.88	2.25	H	9.63	48.00									
20.13	C	12.88	3.13	a	10.50	4.63	s	10.63	3.13	s	10.63	16.00	A	16.13	2.00	v	12.38	3.25	e	10.50	20.13			
43.75	1/4	20.13	15.00	M	9.38	2.75	I	2.00	2.75	L	7.50	1.50	E	7.50	43.75									

MODEL: D:\p\p\Design\KKS\Signs\_Design\Contract-46556\Signs\_Structure\Design-155\_and-1200\_Comp\4-Enc-84-co\Wcnc-R01\CDD\6127155\_Signs\csp-IP-KK-COM\BIBED-06-28-21.com  
FILE NAME: S:\IP\Design\KKS\Signs\_Design\Contract-46556\Signs\_Structure\Design-155\_and-1200\_Comp\4-Enc-84-co\Wcnc-R01\CDD\6127155\_Signs\csp-IP-KK-COM\BIBED-06-28-21.com

USER NAME = plascencal	DESIGNED - KK	REVISED -
DRAWN - KK / IP	REVISOR -	
PLOT SCALE = 40,0000 * / in.	CHECKED - LP	REVISOR -
PLOT DATE = 7/1/2021	DATE - 06/25/2021	REVISOR -

**STATE OF ILLINOIS**  
**DEPARTMENT OF TRANSPORTATION**

<b>SIGN PANEL DESIGN</b>			
SCALE:	SHEET	OF	SHEETS
	STA.		TO STA.

F.A.I. RTE.	SECTION	COUNTY	TOTAL SHEETS	SHEET NO.
55	2021-128-SG	VARIOUS	178	153
CONTRACT NO. 62P27				
ILLINOIS FED. AID PROJECT				

**DETAILS**

"TOLL" PLAQUE DETAIL DESIGN

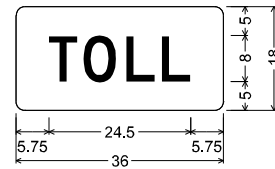

1.50" Radius, 0.00" Border, White on Yellow;

"TOLL" Black, D 2K;

Table of widths and spaces

5.75	T	4.88	1.13	O	5.63	1.75	L	5.00	1.13	L	5.00	5.75
------	---	------	------	---	------	------	---	------	------	---	------	------

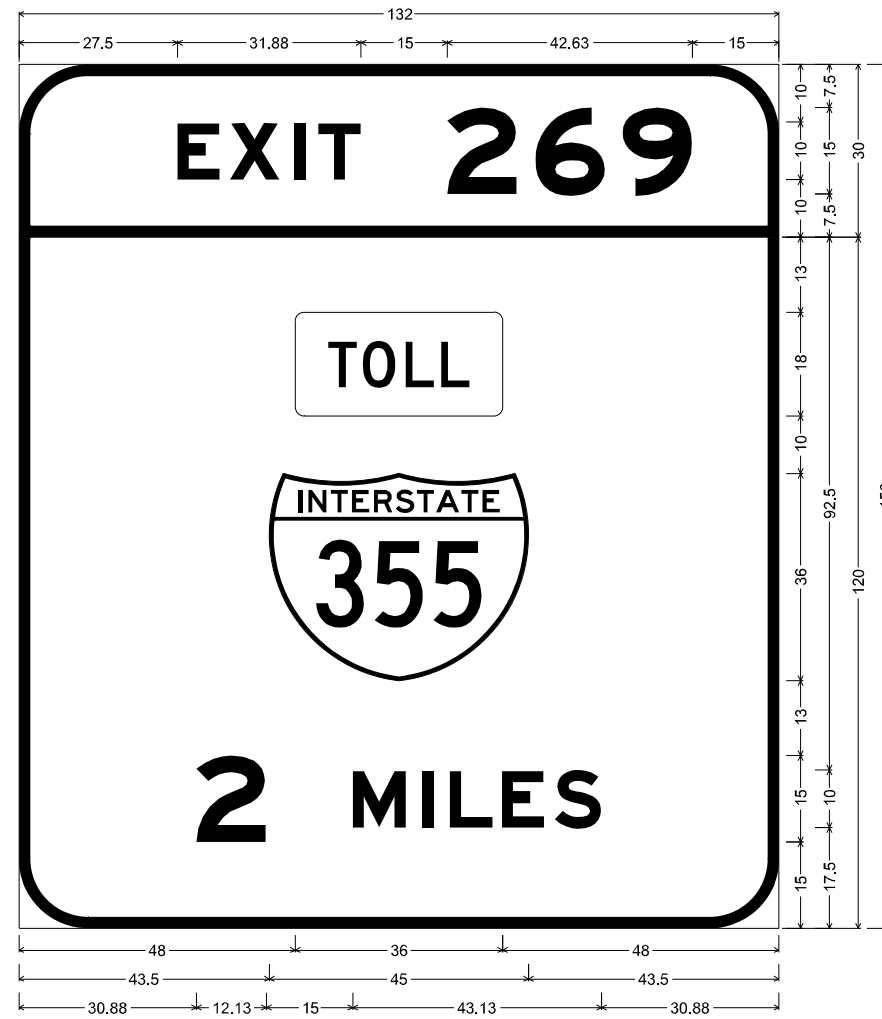

12.00" Radius, 2.00" Border, White on Green;  
 "EXIT", E Mod 2K 120% spacing; "269", E Mod 2K;

12.00" Radius, 2.00" Border, White on Green;  
 Rounded Rectangle 1.50" Radius Yellow;  
 "2 MILES", E Mod 2K;

Table of widths and spaces

27.50	E	7.50	1.63	X	8.75	2.50	I	2.00	2.13	T	7.38	15.00	2	12.13	3.13	6	12.25	3.00	9	12.13	15.00
48.00	□		36.00	48.00																	
43.50	⬮		45.00	43.50																	
30.88	2	12.13	15.00	M	9.25	2.88	I	1.88	2.88	L	7.38	1.63	E	7.38	1.75	S	8.13	30.88			

STRUCTURE NUMBER		1G022I055L272.0-000	
LOCATION		108 EXPRESSWAY	
SIZE (W x H)	EXIT PLAQUE	-	
	MAIN PANEL	11' X 12.5'	
MOUNTING / TYPE		GROUND	
MOUNTING LOC (L, M, R)		RIGHT	
SHEETING / COLOR	BACKGROUND	TYPE:	ZZ
		COLOR:	GREEN
		TYPE:	
	LEGEND / BORDER	COLOR:	
		TYPE:	ZZ
		COLOR:	WHITE

MODEL: D:\p\h  
 FILE NAME: S:\IP\Design\KKS\Signs Design\Contract-46556-Signs-Structure-Design-155-and-1200-County-4-Line-84-co-Water-Rd\CADD\62P27155\_Signs-IP-KK-COMBINED-06-28-21.dwg

USER NAME = plascencjal	DESIGNED - KK	REVISED -
DRAWN - KK / IP	DRAWN - KK / IP	REVISED -
PLOT SCALE = 40,0000 * / in.	CHECKED - LP	REVISED -
PLOT DATE = 7/1/2021	DATE - 06/25/2021	REVISED -

**STATE OF ILLINOIS  
 DEPARTMENT OF TRANSPORTATION**

**SIGN PANEL DESIGN**

SCALE: SHEET OF SHEETS STA. TO STA.

F.A.I. RTE.	SECTION	COUNTY	TOTAL SHEETS	SHEET NO.
55	2021-128-SG	VARIOUS	178	154
CONTRACT NO. 62P27				
ILLINOIS FED. AID PROJECT				

STRUCTURE NUMBER		1G022I055L271.5-000	
LOCATION		109 EXPRESSWAY	
SIZE (W x H)	EXIT PLAQUE	-	
	MAIN PANEL	13.5' X 11'	
MOUNTING / TYPE		GROUND	
MOUNTING LOC (L, M, R)		RIGHT	
SHEETING / COLOR	BACKGROUND	TYPE:	ZZ
		COLOR:	GREEN
		TYPE:	
		COLOR:	
	LEGEND / BORDER	TYPE:	ZZ
		COLOR:	WHITE
		TYPE:	
		COLOR:	

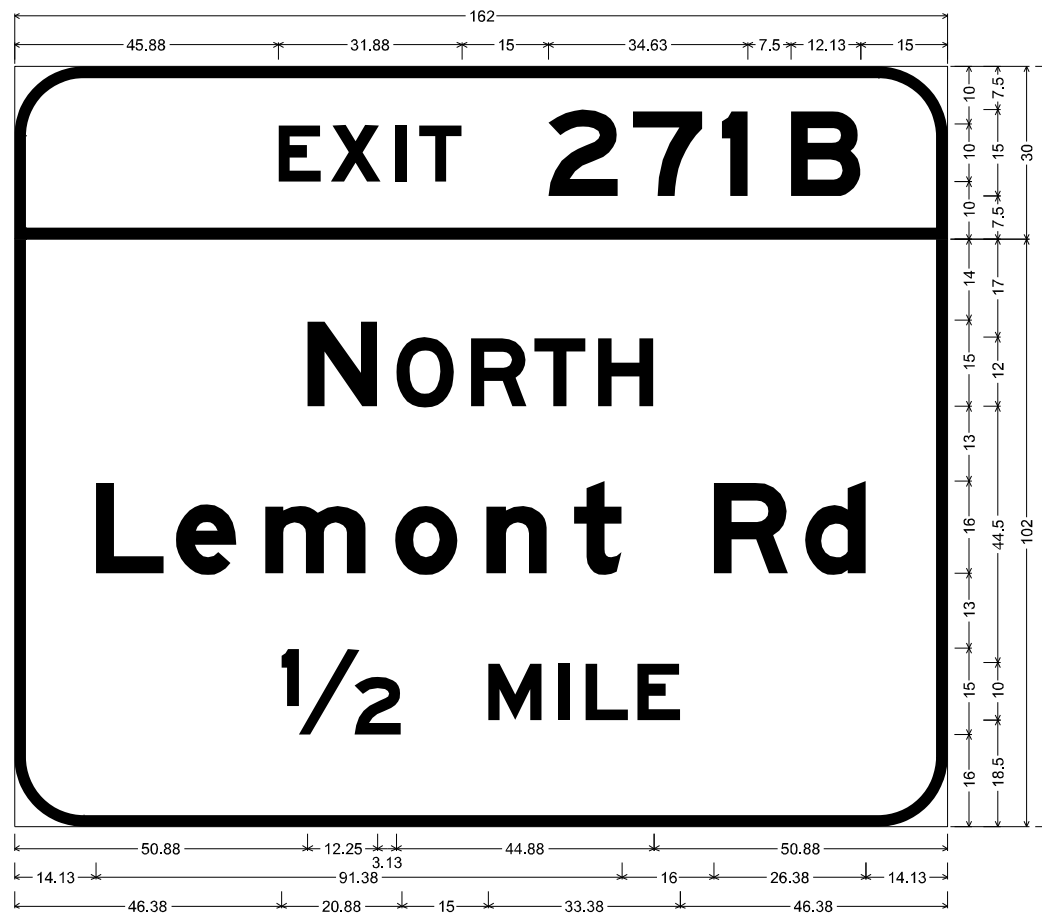

12.00" Radius, 2.00" Border, White on Green;  
 "EXIT", E Mod 2K 120% spacing; "271", E Mod 2K; "B", E Mod 2K;

12.00" Radius, 2.00" Border, White on Green;  
 "NORTH", E Mod 2K; "Lemont Rd", E Mod 2K; "1/2 MILE", E Mod 2K;

Table of widths and spaces

45.88	E	7.38	1.63	X	8.75	2.50	2.00	2.13	T	7.38	15.00	2	12.25	2.50	7	12.13	3.38	1	4.50	7.50	B	12.13	15.00	
50.88	N	12.25	3.13	O	10.13	2.88	9.75	1.25	T	8.88	2.25	H	9.63	51.00										
14.13	L	11.88	2.00	e	10.63	4.88	m	17.63	5.00	o	10.88	4.88	n	10.63	4.63	t	8.25	16.00	R	13.00	2.88	d	10.63	14.13
46.38	1/2	20.88	15.00	M	9.38	2.75	I	2.00	2.88	L	7.38	1.63	E	7.38	46.38									

MODEL: D:\p1\...  
 FILE NAME: S:\P1\Design\KKS\Signs Design\Contract-46556-Signs-Structure-Design-155-and-1200-County-4-Hwy-84-co-Water-Rd\CADD\62P27155\_Signs\KKS-IP-KK-CO\BIBED-06-28-21.dwg

USER NAME = plascencjal	DESIGNED - KK	REVISED -
DRAWN - KK / IP	REVISOR -	
PLOT SCALE = 40,0000 * / in.	CHECKED - LP	REVISED -
PLOT DATE = 7/1/2021	DATE - 06/25/2021	REVISED -

**STATE OF ILLINOIS  
 DEPARTMENT OF TRANSPORTATION**

<b>SIGN PANEL DESIGN</b>				
SCALE:	SHEET	OF	SHEETS	STA. TO STA.

F.A.I. RTE.	SECTION	COUNTY	TOTAL SHEETS	SHEET NO.
55	2021-128-SG	VARIOUS	178	155
CONTRACT NO. 62P27				
ILLINOIS FED. AID PROJECT				

STRUCTURE NUMBER		1G022I055L270.5-000
LOCATION		110 EXPRESSWAY
SIZE (W x H)	EXIT PLAQUE	-
	MAIN PANEL	12' X 11'
MOUNTING / TYPE		GROUND
MOUNTING LOC (L, M, R)		RIGHT
SHEETING / COLOR	BACKGROUND	TYPE: ZZ
		COLOR: GREEN
		TYPE:
	LEGEND / BORDER	TYPE: ZZ
		COLOR: WHITE
		TYPE:
		COLOR:

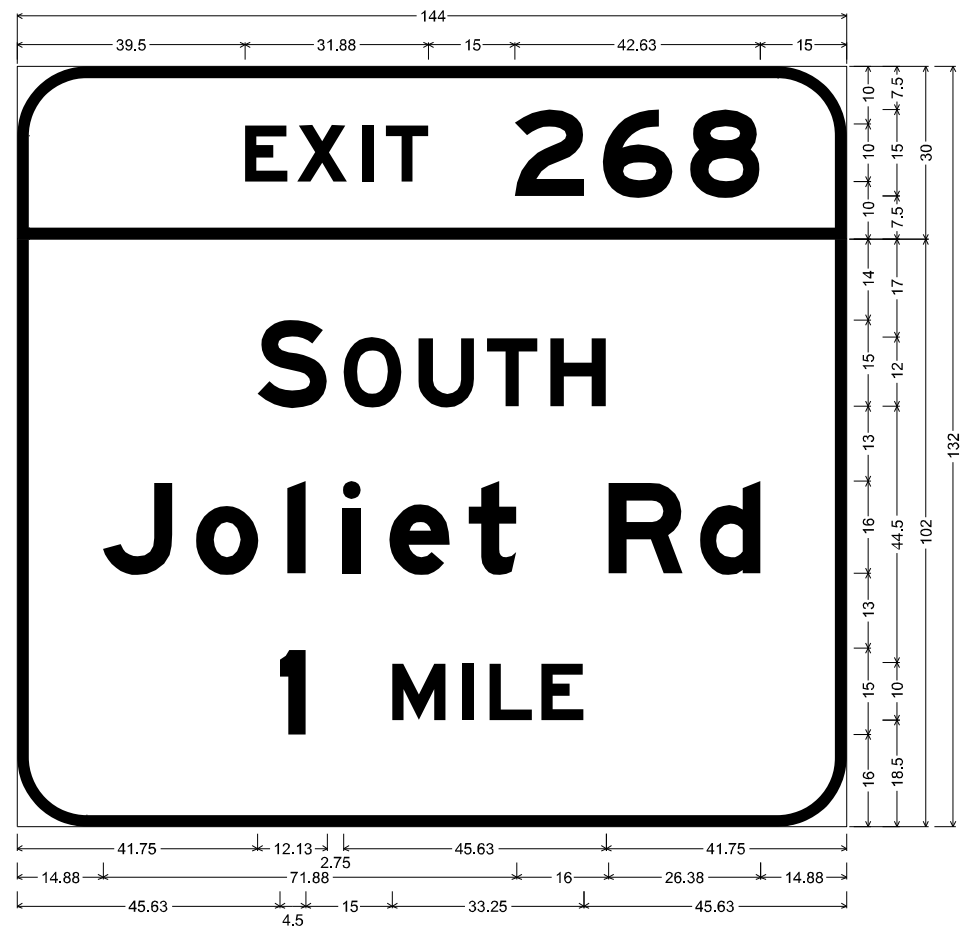

12.00" Radius, 2.00" Border, White on Green;  
 "EXIT", E Mod 2K 120% spacing; "268", E Mod 2K;  
 12.00" Radius, 2.00" Border, White on Green;  
 "SOUTH", E Mod 2K; "Joliet Rd", E Mod 2K; "1 MILE", E Mod 2K;  
 Table of widths and spaces

39.50	E	7.50	1.63	X	8.75	2.50	I	2.00	2.13	T	7.38	15.00	2	12.13	3.13	6	12.25	3.00	8	12.13	15.00			
41.75	S	12.13	2.75	O	10.13	2.88	U	9.75	2.13	T	8.88	2.13	H	9.75	41.75									
14.88	J	12.13	4.00	o	10.88	5.00	i	3.25	6.38	i	3.13	5.00	e	10.50	3.25	t	8.38	16.00	R	12.88	2.88	d	10.63	14.88
45.63	I	4.50	15.00	M	9.25	2.88	I	2.00	2.75	L	7.38	1.63	E	7.38	45.63									

MODEL: D:\p\p\Design\KKS\Signs\_Design\Contract-48556\Signs\_Structure\Design-155\_and-1200\County4\Enc-84\co\Water-Rd\CADD\62P27155\_Signs\cIP-KK.COM\BIBED-06-28-21.com  
 FILE NAME: S:\IP\Design\KKS\Signs\_Design\Contract-48556\Signs\_Structure\Design-155\_and-1200\County4\Enc-84\co\Water-Rd\CADD\62P27155\_Signs\cIP-KK.COM\BIBED-06-28-21.com

USER NAME = plascencjal	DESIGNED - KK	REVISED -
DRAWN - KK / IP	REVISIONS -	
PLOT SCALE = 40,0000 * / in.	CHECKED - LP	REVISED -
PLOT DATE = 7/1/2021	DATE - 06/25/2021	REVISED -

**STATE OF ILLINOIS**  
**DEPARTMENT OF TRANSPORTATION**

<b>SIGN PANEL DESIGN</b>			
SCALE:	SHEET	OF	SHEETS
	STA.		TO STA.

F.A.I. RTE.	SECTION	COUNTY	TOTAL SHEETS	SHEET NO.
55	2021-128-SG	VARIOUS	178	156
			CONTRACT NO. 62P27	
		ILLINOIS	FED. AID PROJECT	



STRUCTURE NUMBER		1G022I055L270.0-000	
LOCATION		111 EXPRESSWAY	
SIZE (W x H)	EXIT PLAQUE	-	
	MAIN PANEL	14' X 6'	
MOUNTING / TYPE		GROUND	
MOUNTING LOC (L, M, R)		RIGHT	
SHEETING / COLOR	BACKGROUND	TYPE:	ZZ
		COLOR:	GREEN
		TYPE:	
	LEGEND / BORDER	COLOR:	
		TYPE:	ZZ
		COLOR:	WHITE

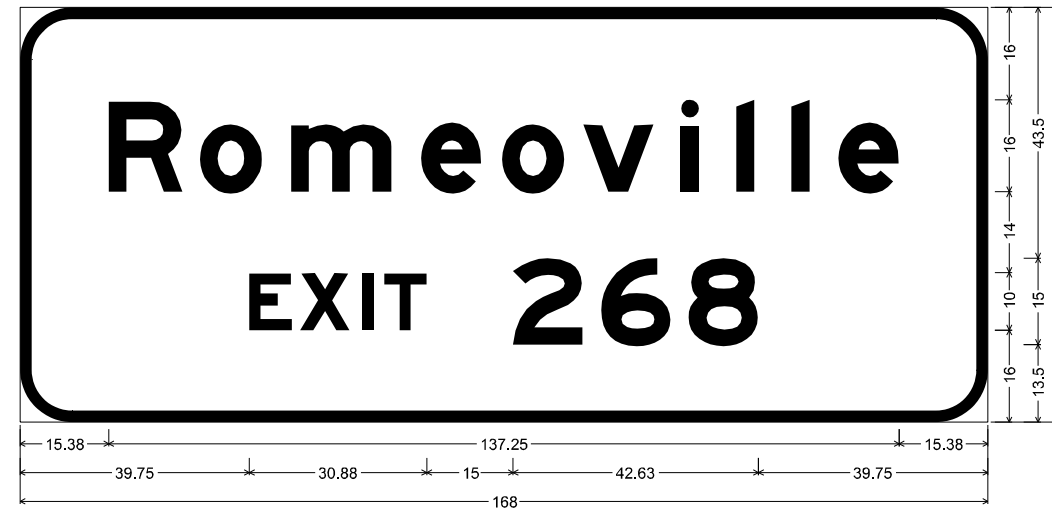

9.00" Radius, 2.00" Border, White on Green;  
 "Romeoville", E Mod 2K; "EXIT 268", E Mod 2K;

Table of widths and spaces

15.38	R	13.00	2.88	o	10.88	4.88	m	17.63	5.00	e	10.50	3.50	o	10.88	3.25	v	12.25	4.75	i	3.13	6.38	l	3.25	6.38	l	3.25	4.88	e	10.63	15.38
39.75	E	7.50	1.38	X	8.63	2.13	l	2.00	1.75	T	7.50	15.00	z	12.13	3.13	6	12.13	3.00	8	12.13	39.88									

MODEL: D:\p\h  
 FILE NAME: S:\IP\Design\KKS\Signs Design\Contract-48556-Signs-Structure-Design-155-and-1200-County-4-Enc-84-co-Water-Rd\CADD\62P27-155\_Signs\KKS-IP-KK-COMBINED-06-28-21.dwg

USER NAME = plascencjal	DESIGNED - KK	REVISED -
	DRAWN - KK / IP	REVISED -
PLOT SCALE = 40,0000 * / in.	CHECKED - LP	REVISED -
PLOT DATE = 7/1/2021	DATE - 06/25/2021	REVISED -

**STATE OF ILLINOIS  
DEPARTMENT OF TRANSPORTATION**

**SIGN PANEL DESIGN**

SCALE: SHEET OF SHEETS STA. TO STA.

F.A.I. RTE.	SECTION	COUNTY	TOTAL SHEETS	SHEET NO.
55	2021-128-SG	VARIOUS	178	157
CONTRACT NO. 62P27			ILLINOIS FED. AID PROJECT	

STRUCTURE NUMBER		1G099I055L268.0-001	
LOCATION		112 EXPRESSWAY	
SIZE (W x H)	EXIT PLAQUE	-	
	MAIN PANEL	15' X 12.5'	
MOUNTING / TYPE		GROUND	
MOUNTING LOC (L, M, R)		RIGHT	
SHEETING / COLOR	BACKGROUND	TYPE:	ZZ
		COLOR:	GREEN
		TYPE:	
	LEGEND / BORDER	COLOR:	
		TYPE:	ZZ
		COLOR:	WHITE

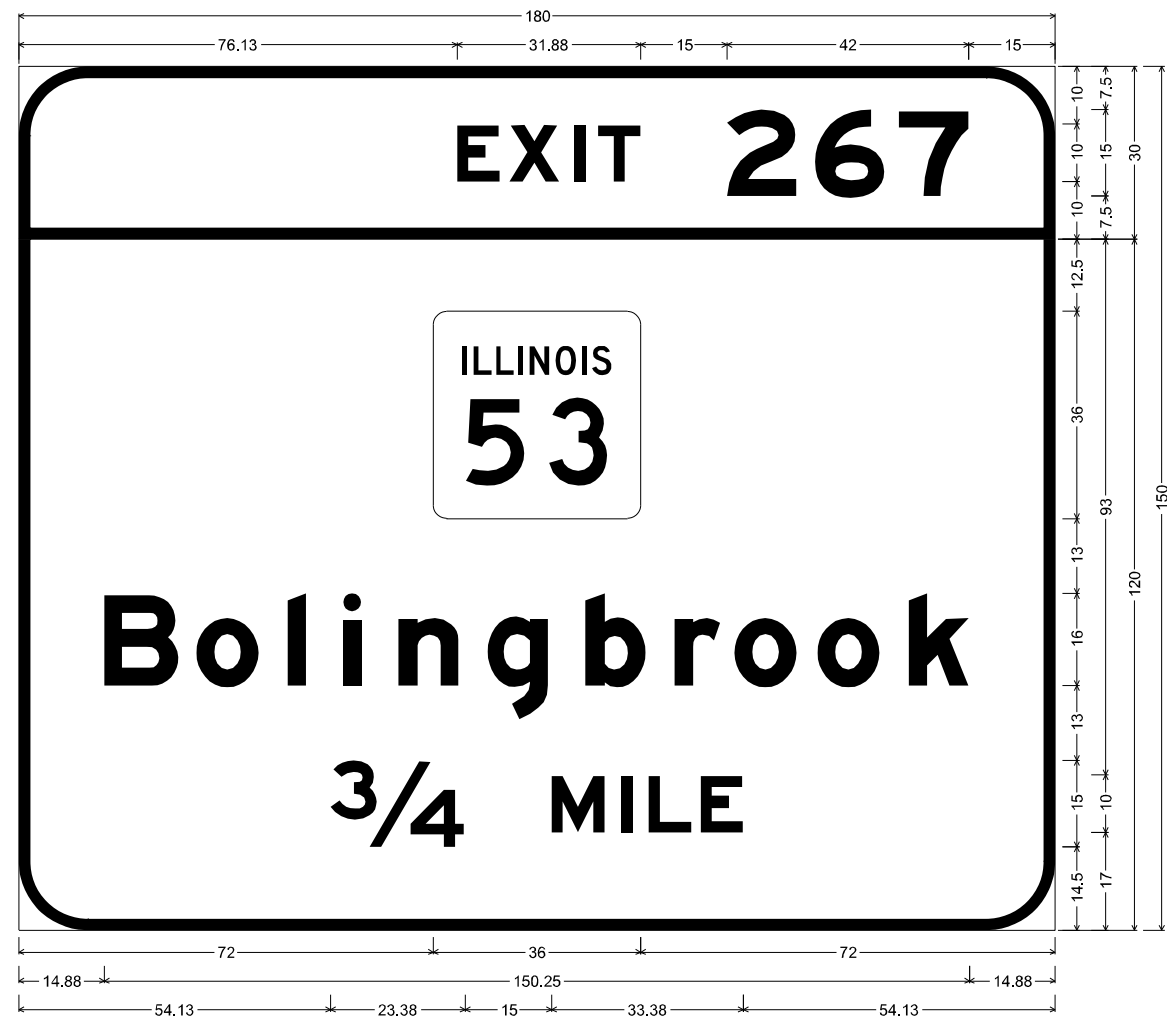

12.00" Radius, 2.00" Border, White on Green;  
 "EXIT", E Mod 2K 120% spacing; "267", E Mod 2K;

12.00" Radius, 2.00" Border, White on Green;  
 "Bolingbrook", E Mod 2K; "3/4 MILE", E Mod 2K;

Table of widths and spaces

76.13	E	7.38	X	1.75	8.63	I	2.50	2.00	2.25	T	7.38	15.00	Z	12.13	3.13	6	12.13	2.50	7	12.13	15.00												
72.00	B			36.00	M			72.00																									
14.88	B	13.00	3.00	o	10.88	5.00	i	3.13	6.38	i	3.25	6.38	n	10.63	4.88	g	10.63	6.38	b	10.50	5.00	r	8.00	2.38	o	10.88	3.50	o	10.88	5.00	k	10.50	15.00
54.13	3/4	23.38	15.00	M	9.38	2.75	I	2.00	2.75	L	7.50	1.50	E	7.50	54.13																		

MODEL: D:\p\p\...  
 FILE NAME: S:\P\Design\KKS\Signs\_Design\Contract-46556-Signs-Structure-Design-155\_and-1200-County-4-Enc-84-co-Water-Rd\CADD\62P27155\_Signs\KKS-IP-KK-COM\BRED-06-28-21.dwg

USER NAME = plascencjal	DESIGNED - KK	REVISED -
DRAWN - KK / IP	REVISOR -	
PLOT SCALE = 40,0000 * / in.	CHECKED - LP	REVISOR -
PLOT DATE = 7/1/2021	DATE - 06/25/2021	REVISOR -

**STATE OF ILLINOIS  
DEPARTMENT OF TRANSPORTATION**

**SIGN PANEL DESIGN**

SCALE: SHEET OF SHEETS STA. TO STA.

F.A.I. RTE.	SECTION	COUNTY	TOTAL SHEETS	SHEET NO.
55	2021-128-SG	VARIOUS	178	158
CONTRACT NO. 62P27			ILLINOIS FED. AID PROJECT	

STRUCTURE NUMBER		1G0991055L266.8-000	
LOCATION		113 EXPRESSWAY	
SIZE (W x H)	EXIT PLAQUE	-	
	MAIN PANEL	13.5' X 8'	
MOUNTING / TYPE		GROUND	
MOUNTING LOC (L, M, R)		RIGHT	
SHEETING / COLOR	BACKGROUND	TYPE:	ZZ
		COLOR:	GREEN
		TYPE:	
		COLOR:	
	LEGEND / BORDER	TYPE:	ZZ
		COLOR:	WHITE
		TYPE:	
		COLOR:	

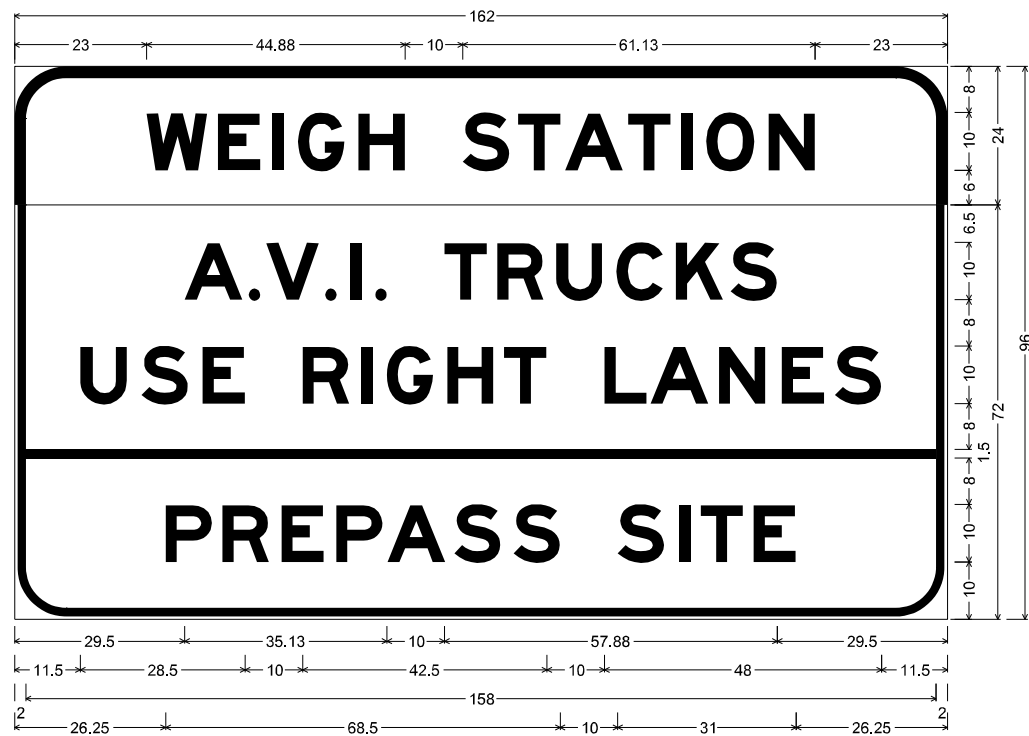

9.00" Radius, 2.00" Border, White on Green;  
 "WEIGH STATION", E Mod 2K;

9.00" Radius, 1.50" Border, 0.50" Indent, Black on White;  
 "A.V.I.", E Mod 2K 130% spacing; "TRUCKS", E Mod 2K; "USE RIGHT LANES", E Mod 2K;  
 "PREPASS SITE", E Mod 2K;

Table of widths and spaces

23.00	W	10.50	E	1.88	7.38	I	2.00	2.38	G	8.13	H	8.13																				
10.00	S	8.00	T	1.50	7.50	A	0.75	10.13	T	7.38	I	1.88	2.00	2.38	O	8.38	2.38	N	8.13	22.88												
29.50	A	10.13	1.00	2.00	1.13	V	9.13	1.13	2.00	2.25	I	2.38	2.00																			
10.00	T	7.38	1.88	8.00	2.13	U	8.13	2.38	C	8.13	2.13	K	8.25	1.25	8.13	29.50																
11.50	U	8.00	2.50	8.13	2.50	E	7.38	10.00	8.13	2.13	I	2.00	2.38	G	8.13	2.38	H	8.13	1.75	T	7.38											
10.00	L	7.38	0.63	A	10.13	N	1.75	8.13	2.75	E	7.50	1.75	S	8.13	11.38																	
2.00	158.00																					2.00										
26.25	P	8.13	1.75	R	8.13	2.13	7.38	2.13	P	8.00	0.88	A	10.13	1.50	8.00	2.25	S	8.13														
10.00	S	8.00	2.50	I	2.00	1.88	T	7.38	1.75	E	7.50	26.25																				

MODEL: D:\p\h...  
 FILE NAME: S:\IP\Design\KKS\Signs\_Design\Contract-46556-Signs-Structure-Design-155-and-1200-County-4-Enc-R4-co-Water-Rd\CADD\62P27-155\_Signs\KKS-IP-KK-COMBINED-06-28-21.dwg

USER NAME = plascencjal PLOT SCALE = 40,0000 */ in. PLOT DATE = 7/1/2021	DESIGNED - KK DRAWN - KK / IP CHECKED - LP DATE - 06/25/2021	REVISED - REVISED - REVISED - REVISED -	<b>STATE OF ILLINOIS          DEPARTMENT OF TRANSPORTATION</b>	<b>SIGN PANEL DESIGN</b>				F.A.I. RTE. 55 SECTION 2021-128-SG COUNTY VARIOUS ILLINOIS FED. AID PROJECT	TOTAL SHEETS 178 SHEET NO. 159 CONTRACT NO. 62P27
				SCALE:	SHEET OF SHEETS	STA. TO STA.			

STRUCTURE NUMBER		1G0991055L266.0-000	
LOCATION		114 EXPRESSWAY	
SIZE (W x H)	EXIT PLAQUE	-	
	MAIN PANEL	11' X 7'	
MOUNTING / TYPE		GROUND	
MOUNTING LOC (L, M, R)		RIGHT	
SHEETING / COLOR	BACKGROUND	TYPE:	ZZ
		COLOR:	GREEN
		TYPE:	
		COLOR:	
	LEGEND / BORDER	TYPE:	ZZ
		COLOR:	WHITE
		TYPE:	
		COLOR:	

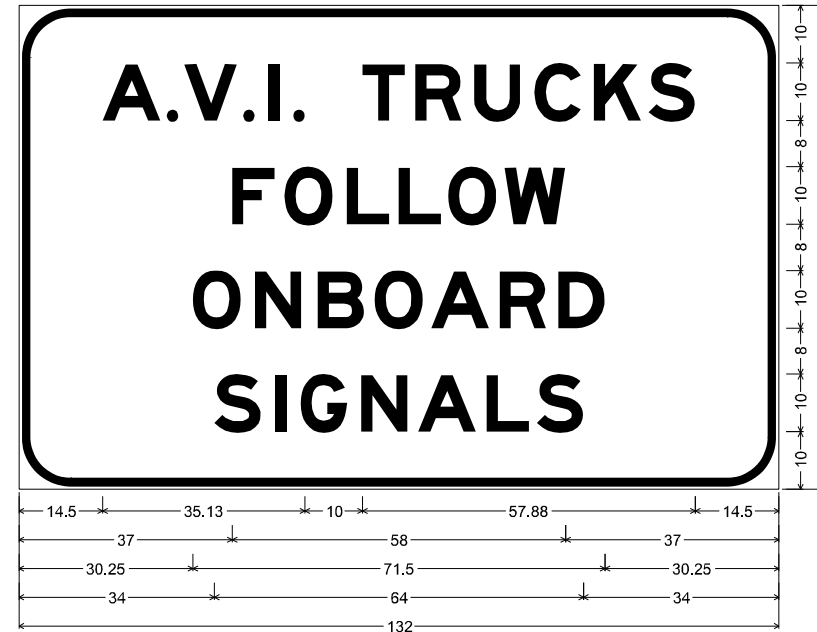

9.00" Radius, 1.50" Border, 0.50" Indent, Black on White;  
 "A.V.I.", E Mod 2K 130% spacing; "TRUCKS", E Mod 2K; "FOLLOW", E Mod 2K;  
 "ONBOARD", E Mod 2K; "SIGNALS", E Mod 2K;

Table of widths and spaces

14.50	A	10.13	1.00	2.00	1.13	V	9.13	1.13	2.00	2.25	I	2.00	2.38	2.00
	T	7.38	1.88	R	8.00	2.13	U	8.13	2.38	8.13	2.13	8.25	1.25	8.13
37.00	F	7.50	1.63	O	8.38	2.50	L	7.38	1.50	7.50	1.13	O	8.38	1.50
	N	8.38	2.38	8.13	2.75	B	8.13	1.75	8.38	1.50	10.00	1.88	8.13	2.00
30.25	S	8.00	2.50	I	2.00	G	8.00	2.50	8.00	1.88	A	10.13	1.75	7.38
	L	7.38	1.25	S	8.13	34.00								

MODEL: D:\p\p\Design\KKS\Signs Design\Contract-48556\Signs\Structure\Design-155\_and-1200\County\Hec-84\Loc\Wagon-Rd\CDD\62P27-155\_Signs\KKS-IP-KK-COMBINED-06-28-21.dwg  
 FILE NAME: Sign\IP\Design\KKS\Signs Design\Contract-48556\Signs\Structure\Design-155\_and-1200\County\Hec-84\Loc\Wagon-Rd\CDD\62P27-155\_Signs\KKS-IP-KK-COMBINED-06-28-21.dwg

USER NAME = plascenciaj	DESIGNED - KK	REVISED -
DRAWN - KK / IP	REVISIONS	REVISED -
PLOT SCALE = 40,0000 * / in.	CHECKED - LP	REVISED -
PLOT DATE = 7/1/2021	DATE - 06/25/2021	REVISED -

**STATE OF ILLINOIS**  
**DEPARTMENT OF TRANSPORTATION**

**SIGN PANEL DESIGN**

SCALE: SHEET OF SHEETS STA. TO STA.

F.A.I. RTE.	SECTION	COUNTY	TOTAL SHEETS	SHEET NO.
55	2021-128-5G	VARIOUS	178	160
CONTRACT NO. 62P27				
ILLINOIS FED. AID PROJECT				

STRUCTURE NUMBER		1G099I055L265.9-000	
LOCATION		115 EXPRESSWAY	
SIZE (W x H)	EXIT PLAQUE	-	
	MAIN PANEL	9.5' X 6'	
MOUNTING / TYPE		GROUND	
MOUNTING LOC (L, M, R)		RIGHT	
SHEETING / COLOR	BACKGROUND	TYPE:	ZZ
		COLOR:	GREEN
		TYPE:	
	LEGEND / BORDER	COLOR:	
		TYPE:	ZZ
		COLOR:	WHITE

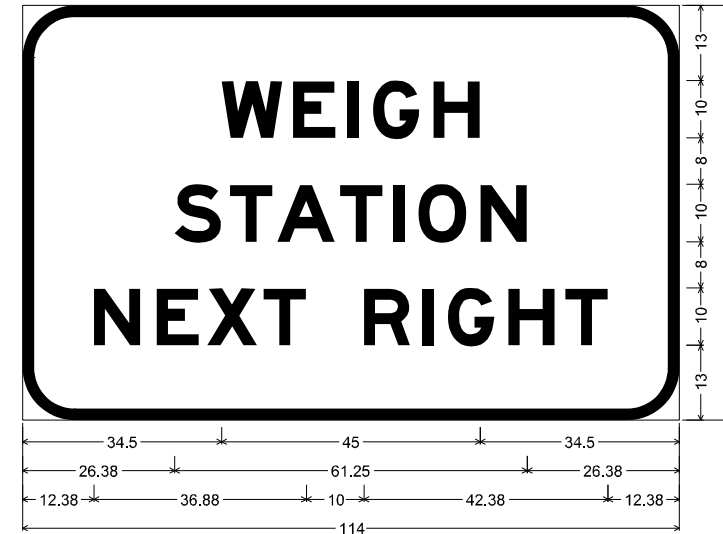

9.00" Radius, 2.00" Border, White on Green;  
 "WEIGH", E Mod 2K; "STATION", E Mod 2K; "NEXT RIGHT", E Mod 2K;  
 Table of widths and spaces

34.50	W	10.63	1.88	E	7.38	2.00	I	2.00	2.50	G	8.00	2.50	H	8.00	34.63				
26.38	S	8.13	1.50	T	7.38	0.75	A	10.13	0.88	T	7.38	1.75	I	2.00	2.38	8.50	2.38	8.00	26.50
12.38	N	8.13	2.75	E	7.38	1.38	X	8.75	1.13	T	7.38								
	R	10.00	8.13	2.00	I	2.00	2.50	G	8.00	2.50	H	8.00	1.88	T	7.38	12.38			

MODEL: D:\p\h  
 FILE NAME: S:\IP\Design\KKS\Signs Design\Contract-48556-Signs-Structure-Design-155-and-1200-County-4-Enc-84-co-Water-Rd\CADD\62P27-155\_Signs-IP-KK-COMBINED-06-28-21.dwg

USER NAME = plascencjal	DESIGNED - KK	REVISED -
DRAWN - KK / IP	CHECKED - LP	REVISED -
PLOT SCALE = 40,0000 * / in.	DATE - 06/25/2021	REVISED -
PLOT DATE = 7/1/2021		

**STATE OF ILLINOIS  
DEPARTMENT OF TRANSPORTATION**

**SIGN PANEL DESIGN**

SCALE: SHEET OF SHEETS STA. TO STA.

F.A.I. RTE.	SECTION	COUNTY	TOTAL SHEETS	SHEET NO.
55	2021-128-SG	VARIOUS	178	161
CONTRACT NO. 62P27				
ILLINOIS FED. AID PROJECT				

STRUCTURE NUMBER		1G0991055L265.5-000	
LOCATION		116	EXPRESSWAY
SIZE (W x H)	EXIT PLAQUE	-	
	MAIN PANEL	9.5' X 8.5'	
MOUNTING / TYPE		GROUND	
MOUNTING LOC (L, M, R)		RIGHT	
SHEETING / COLOR	BACKGROUND	TYPE:	ZZ
		COLOR:	GREEN
		TYPE:	
	LEGEND / BORDER	COLOR:	
		TYPE:	ZZ
		COLOR:	WHITE

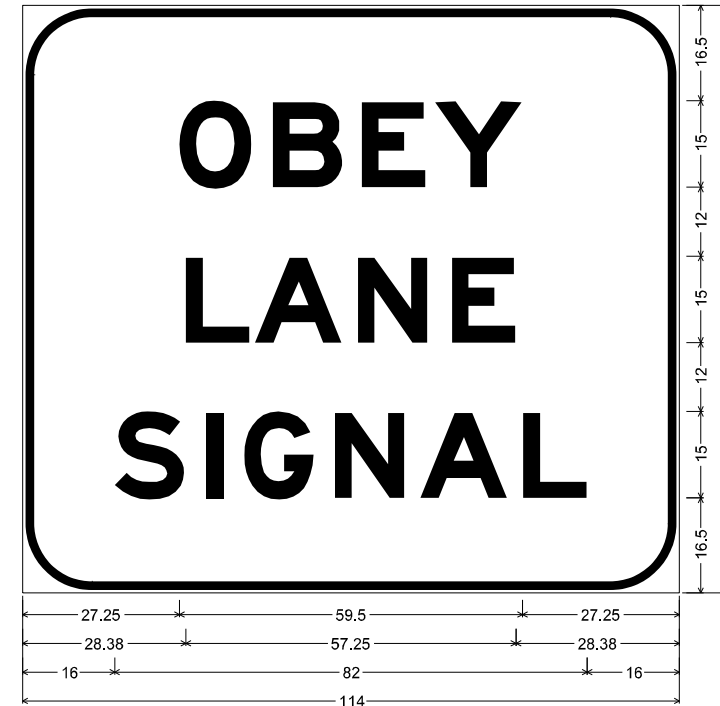

12.00" Radius, 1.50" Border, 0.50" Indent, Black on White;  
 "OBEY", E Mod 2K; "LANE", E Mod 2K; "SIGNAL", E Mod 2K;

Table of widths and spaces

27.25	<b>O</b>	12.63	3.50	<b>B</b>	12.25	3.25	<b>E</b>	11.13	1.63	<b>Y</b>	15.13	27.25						
28.38	<b>L</b>	11.13	0.88	<b>A</b>	15.13	2.63	<b>N</b>	12.25	4.13	<b>E</b>	11.13	28.38						
16.00	<b>S</b>	12.13	3.75	<b>I</b>	3.00	3.63	<b>G</b>	12.13	3.63	<b>N</b>	12.13	2.63	<b>A</b>	15.25	2.63	<b>L</b>	11.13	16.00

MODEL: Default  
 FILE NAME: S:\IP\Design\KKS\Signs Design\Contract-46556-Signs-Structure-Design-155-and-1200-County-1-Enc-84-co-1\Wor-60\CDD\62P27-155\_Signs\KKS-IP-KK-COM\BRED-06-28-21.dwg

USER NAME = plascencjal	DESIGNED - KK	REVISED -
	DRAWN - KK / IP	REVISED -
PLOT SCALE = 40,0000 * / in.	CHECKED - LP	REVISED -
PLOT DATE = 7/1/2021	DATE - 06/25/2021	REVISED -

**STATE OF ILLINOIS  
DEPARTMENT OF TRANSPORTATION**

**SIGN PANEL DESIGN**

SCALE: SHEET OF SHEETS STA. TO STA.

F.A.I. RTE.	SECTION	COUNTY	TOTAL SHEETS	SHEET NO.
55	2021-128-SG	VARIOUS	178	162
CONTRACT NO. 62P27			ILLINOIS FED. AID PROJECT	

STRUCTURE NUMBER		1G0991055R264.0-000	
LOCATION		118 EXPRESSWAY	
SIZE (W x H)	EXIT PLAQUE	-	
	MAIN PANEL	12' X 8.5'	
MOUNTING / TYPE		GROUND	
MOUNTING LOC (L, M, R)		RIGHT	
SHEETING / COLOR	BACKGROUND	TYPE:	ZZ
		COLOR:	GREEN
		TYPE:	
		COLOR:	
	LEGEND / BORDER	TYPE:	ZZ
		COLOR:	WHITE
		TYPE:	
		COLOR:	

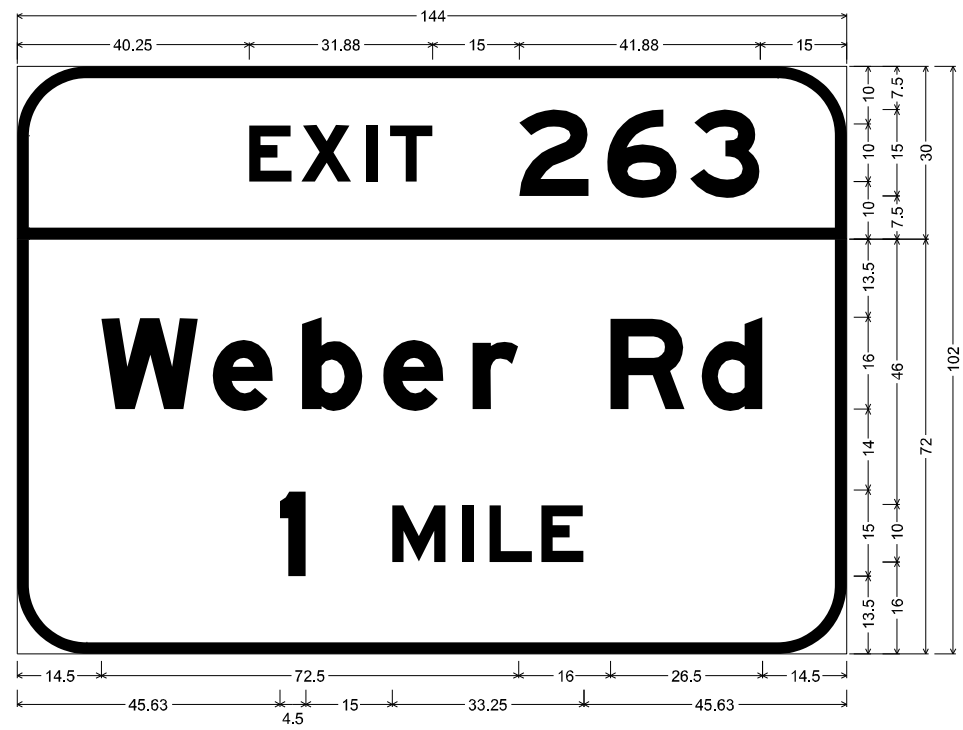

12.00" Radius, 2.00" Border, White on Green;  
 "EXIT", E Mod 2K 120% spacing; "263", E Mod 2K;

12.00" Radius, 2.00" Border, White on Green;  
 "Weber Rd", E Mod 2K; "1 MILE", E Mod 2K;

Table of widths and spaces

40.25	<b>E</b>	7.50	<b>X</b>	1.63	8.75	2.50	<b>I</b>	2.00	2.13	7.38	15.00	<b>2</b>	12.13	3.13	<b>6</b>	12.25	2.25	<b>3</b>	12.13	15.00
14.50	<b>W</b>	17.00	<b>e</b>	2.38	10.63	4.88	<b>b</b>	10.63	3.50	10.50	5.00	<b>r</b>	8.00	16.00	<b>R</b>	13.00	2.88	<b>d</b>	10.50	14.63
45.63	<b>I</b>	4.50	15.00	<b>M</b>	9.25	2.88	<b>I</b>	2.00	2.75	7.38	1.63	<b>E</b>	7.38	45.63						

MODEL: Default  
 FILE NAME: S:\IP\Design\KKS\Signs Design\Contract-48556-Signs-Structure-Design-155-and-1200-County-Weber-Rd\CADD\62P27-155\_Signs-IP-KK-COMBINED-06-28-21.dwg

USER NAME = plascencjal	DESIGNED - KK	REVISED -
DRAWN - KK / IP	REVISIONS -	
PLOT SCALE = 40,0000 * / in.	CHECKED - LP	REVISED -
PLOT DATE = 7/1/2021	DATE - 06/25/2021	REVISED -

**STATE OF ILLINOIS  
DEPARTMENT OF TRANSPORTATION**

<b>SIGN PANEL DESIGN</b>			
SCALE:	SHEET	OF	SHEETS
	STA.		TO STA.

F.A.I. RTE.	SECTION	COUNTY	TOTAL SHEETS	SHEET NO.
55	2021-128-5G	VARIOUS	178	163
			CONTRACT NO. 62P27	
		ILLINOIS	FED. AID PROJECT	

STRUCTURE NUMBER		1G0991055R264.7-000	
LOCATION		119	EXPRESSWAY
SIZE (W x H)	EXIT PLAQUE	-	
	MAIN PANEL	15' X 15'	
MOUNTING / TYPE		GROUND	
MOUNTING LOC (L, M, R)		RIGHT	
SHEETING / COLOR	BACKGROUND	TYPE:	ZZ
		COLOR:	GREEN
		TYPE:	
	LEGEND / BORDER	TYPE:	ZZ
		COLOR:	WHITE
		COLOR:	



12.00" Radius, 2.00" Border, White on Green;  
 "EXIT", E Mod 2K 120% spacing; "267", E Mod 2K;  
 12.00" Radius, 2.00" Border, White on Green;  
 "Bolingbrook", E Mod 2K; "Romeoville", E Mod 2K; "2 MILES", E Mod 2K;  
 Table of widths and spaces

76.13	E	7.38	X	1.75	I	8.63	2.50	I	2.00	T	2.25	7.38	15.00	2	12.13	3.13	6	12.13	2.50	7	12.13	15.00											
72.00																																	
14.88	B	13.00	3.00	o	10.88	5.00	I	3.13	6.38	i	3.25	6.38	n	10.63	4.88	g	10.63	6.38	b	10.50	5.00	r	8.00	2.38	o	10.88	3.50	o	10.88	5.00	k	10.50	15.00
21.38	R	13.00	2.88	o	10.88	4.88	m	17.63	5.00	e	10.50	3.50	o	10.88	3.25	v	12.25	4.75	i	3.13	6.38	3.25	6.38	3.25	4.88	e	10.63	21.38					
54.88	2	12.13	15.00	M	9.25	2.88	I	1.88	2.88	L	7.38	1.63	E	7.38	1.75	S	8.13	54.88															

MODEL: D:\p\p\Design\KKS\Signs - Design\Contract-48556\Signs-Structure\Design-155\and-1200-County-4\Enc-84\co\Wesner-Rol\CADD\62P27-155\_Signs\csp-IP-KK-COM\BRED-06-28-21.dwg  
 FILE NAME: Sign\IP\Design\KKS\Signs - Design\Contract-48556\Signs-Structure\Design-155\and-1200-County-4\Enc-84\co\Wesner-Rol\CADD\62P27-155\_Signs\csp-IP-KK-COM\BRED-06-28-21.dwg

USER NAME = plascenciaj	DESIGNED - KK	REVISED -
DRAWN - KK / IP	REVISOR -	
PLOT SCALE = 40,0000 * / in.	CHECKED - LP	REVISOR -
PLOT DATE = 7/1/2021	DATE - 06/25/2021	REVISOR -

**STATE OF ILLINOIS**  
**DEPARTMENT OF TRANSPORTATION**

<b>SIGN PANEL DESIGN</b>			
SCALE:	SHEET	OF	SHEETS
	STA.		TO STA.

F.A.I. RTE.	SECTION	COUNTY	TOTAL SHEETS	SHEET NO.
55	2021-128-SG	VARIOUS	178	164
			CONTRACT NO. 62P27	
		ILLINOIS	FED. AID PROJECT	





12.00" Radius, 2.00" Border, White on Green;  
 "EXIT", E Mod 2K 120% spacing; "267", E Mod 2K;

12.00" Radius, 2.00" Border, White on Green;  
 "Bolingbrook", E Mod 2K; "Romeoville", E Mod 2K; "1/4 MILE", E Mod 2K;

Table of widths and spaces

76.13	E	7.38	1.75	X	8.63	2.50	I	2.00	2.25	T	7.38	15.00	Z	12.13	3.13	6	12.13	2.50	7	12.13	15.00												
72.00	36.00	72.00																															
14.88	B	13.00	3.00	o	10.88	5.00	i	3.13	3.25	6.38	3.25	6.38	n	10.63	4.88	g	10.63	6.38	b	10.50	5.00	r	8.00	2.38	o	10.88	3.50	o	10.88	5.00	k	10.50	15.00
21.38	R	13.00	2.88	o	10.88	4.88	m	17.63	5.00	e	10.50	3.50	o	10.88	3.25	v	12.25	4.75	i	3.13	6.38	3.25	6.38	3.25	6.38	3.25	4.88	10.63	21.38				
55.75	1/4	20.13	15.00	M	9.38	2.75	I	2.00	2.75	L	7.50	1.50	E	7.50	55.75																		

STRUCTURE NUMBER	1G0991055R266.0-000	
LOCATION	120A	EXPRESSWAY
SIZE (W x H)	EXIT PLAQUE	-
	MAIN PANEL	15' X 15'
MOUNTING / TYPE	GROUND	
MOUNTING LOC (L, M, R)	TOP	
SHEETING / COLOR	BACKGROUND	TYPE: ZZ
		COLOR: GREEN
		TYPE:
		COLOR:
LEGEND / BORDER	LEGEND / BORDER	TYPE: ZZ
		COLOR: WHITE
		TYPE:
		COLOR:

**DETAILS**

ILLINOIS STANDARD SIGN XM-10  
 24" X 30"

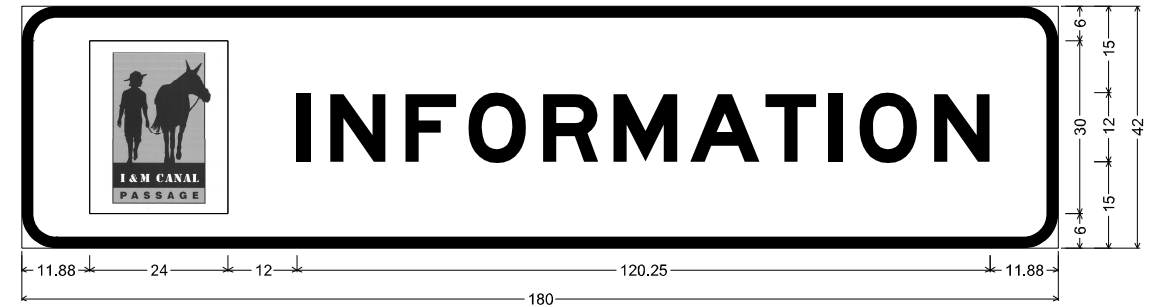
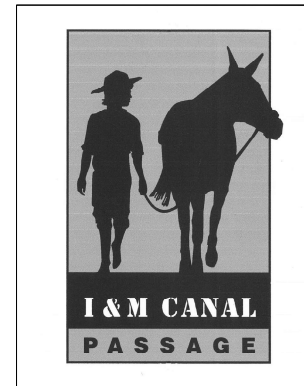

6.00" Radius, 2.00" Border, White on Brown;  
 "INFORMATION", E Mod 2K;

Table of widths and spaces

11.88	24.00																																
12.00	I	2.38	3.38	N	9.63	3.38	F	8.88	2.00	O	10.13	2.88	R	9.75	2.50	M	11.13	2.13	A	12.13	1.00	T	8.88	2.13	I	2.38	2.88	O	10.13	2.88	N	9.75	11.75

STRUCTURE NUMBER	1G0991055R266.0-000			
LOCATION	120B	EXPRESSWAY		
SIZE (W x H)	EXIT PLAQUE	-		
	MAIN PANEL	15' X 3.5'		
MOUNTING / TYPE	GROUND			
MOUNTING LOC (L, M, R)	BOTTOM			
SHEETING / COLOR	BACKGROUND	TYPE: AP		
		COLOR: BROWN		
		TYPE:		
	LEGEND / BORDER	TYPE: ZZ		
		COLOR: WHITE		
		TYPE:		
COLOR:				

MODEL: D:\p\p\...  
 FILE NAME: ...  
 USER: ...  
 DATE: ...  
 SCALE: ...  
 PLOT DATE: ...

USER NAME = plascencal	DESIGNED - KK	REVISED -
PLOT SCALE = 40,0000 * / in.	CHECKED - LP	REVISED -
PLOT DATE = 7/1/2021	DATE - 06/25/2021	REVISED -

**STATE OF ILLINOIS  
 DEPARTMENT OF TRANSPORTATION**

**SIGN PANEL DESIGN**

SCALE: SHEET OF SHEETS STA. TO STA.

F.A.I. RTE.	SECTION	COUNTY	TOTAL SHEETS	SHEET NO.
55	2021-128-SG	VARIOUS	178	165
CONTRACT NO. 62P27				
ILLINOIS FED. AID PROJECT				

**DETAILS**

"TOLL" PLAQUE DETAIL DESIGN

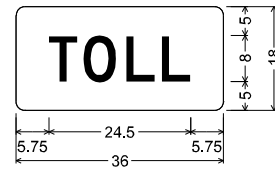

1.50" Radius, 0.00" Border, White on Yellow;

"TOLL" Black, D 2K;

Table of widths and spaces

5.75	T	4.88	1.13	O	5.63	1.75	L	5.00	1.13	L	5.00	5.75
------	---	------	------	---	------	------	---	------	------	---	------	------

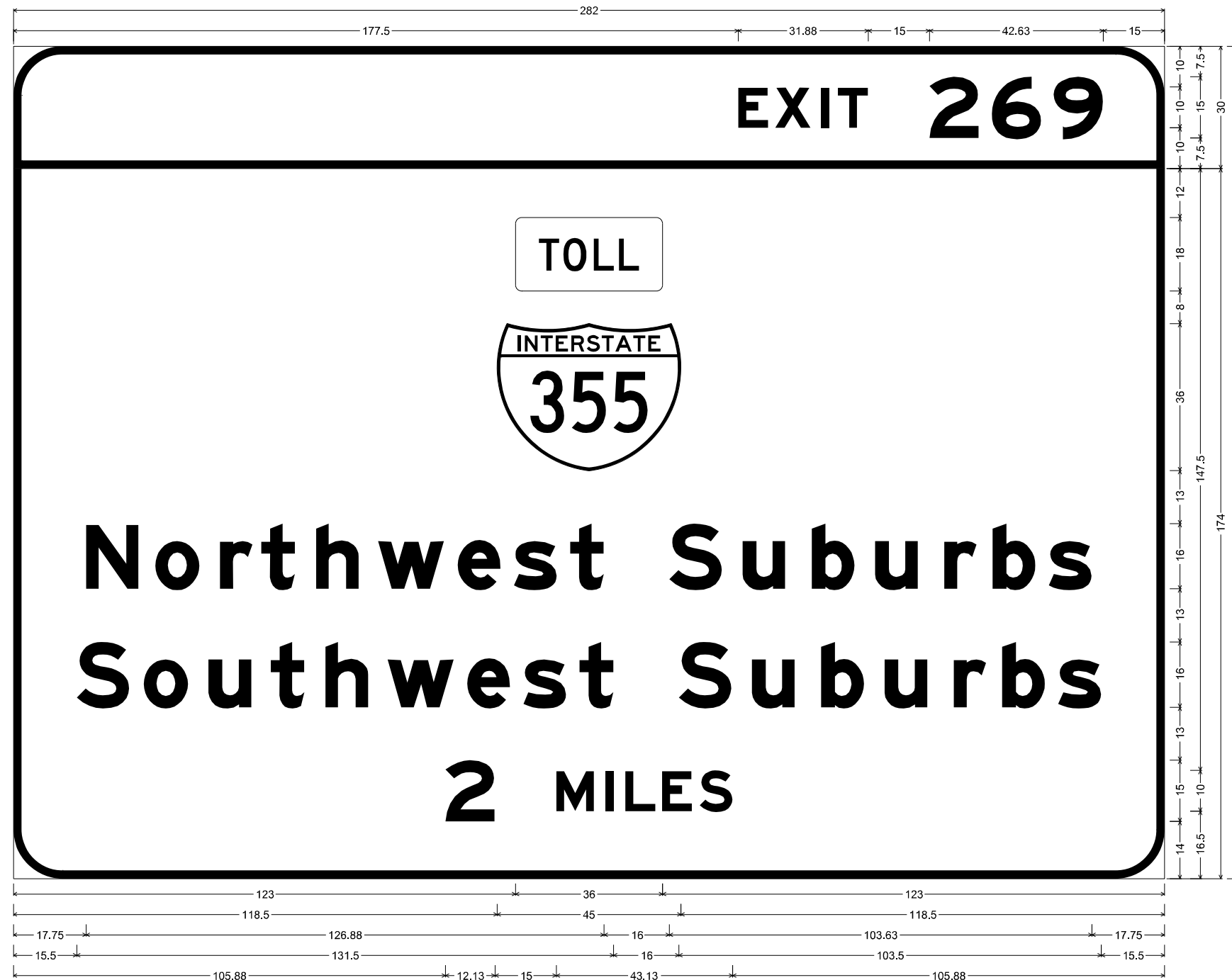

12.00" Radius, 2.00" Border, White on Green;  
 "EXIT", E Mod 2K 120% spacing; "269", E Mod 2K;  
 12.00" Radius, 2.00" Border, White on Green;  
 Rounded Rectangle 1.50" Radius Yellow;  
 "Northwest Suburbs", E Mod 2K; "Southwest Suburbs", E Mod 2K; "2 MILES", E Mod 2K;  
 Table of widths and spaces

177.50	E	7.50	1.63	X	8.75	2.50	I	2.00	2.13	T	7.38	15.00	2	12.13	3.13	6	12.25	3.00	9	12.13	15.00																									
123.00		36.00		123.00																																										
118.50		45.00		118.50																																										
17.75	N	13.00	4.00	o	10.88	5.00	r	8.00	2.00	t	8.38	5.13	h	10.50	4.63	w	16.38	3.25	e	10.50	3.25	10.50	3.25	t	8.25	16.00	S	13.00	5.00	u	10.50	6.38	b	10.63	4.88	10.63	6.38	r	8.00	3.88	b	10.50	3.25	s	10.50	17.88
15.50	S	13.00	3.50	o	10.88	4.88	u	10.63	4.63	t	8.25	5.13	h	10.63	4.63	w	16.25	3.25	e	10.50	3.25	10.63	3.13	8.38	16.00	S	12.88	5.00	u	10.50	6.50	b	10.50	5.00	u	10.50	6.38	r	8.00	3.88	b	10.63	3.13	s	10.63	15.38
105.88	2	12.13	15.00	M	9.25	2.88	1.88	2.88	L	7.38	1.63	7.38	1.75	E	8.13	105.88																														

STRUCTURE NUMBER	1G0991055R266.2-000		
LOCATION	121	EXPRESSWAY	
SIZE (W x H)	EXIT PLAQUE	-	
	MAIN PANEL	23.5' X 17'	
MOUNTING / TYPE	GROUND		
MOUNTING LOC (L, M, R)	RIGHT		
SHEETING / COLOR	BACKGROUND	TYPE:	ZZ
		COLOR:	GREEN
		TYPE:	
	LEGEND / BORDER	COLOR:	
		TYPE:	ZZ
		COLOR:	WHITE
TYPE:			
COLOR:			

MODEL: D:\p\p\Design\KKS\Signs Design\Contract-48556-Signs-Structure-Design-155-and-1200-County-4-Enc-84-co-Wabor-Rd\000\62P27155\_Signs\KKS-IP-KK-COM\BRED-06-28-21.com  
 FILE NAME: S:\IP\Design\KKS\Signs Design\Contract-48556-Signs-Structure-Design-155-and-1200-County-4-Enc-84-co-Wabor-Rd\000\62P27155\_Signs\KKS-IP-KK-COM\BRED-06-28-21.com

USER NAME = plascencjal	DESIGNED - KK	REVISED -
DRAWN - KK / IP	REVISED -	
PLOT SCALE = 40,0000 * / in.	CHECKED - LP	REVISED -
PLOT DATE = 7/1/2021	DATE - 06/25/2021	REVISED -

**STATE OF ILLINOIS**  
**DEPARTMENT OF TRANSPORTATION**

<b>SIGN PANEL DESIGN</b>				
SCALE:	SHEET	OF	SHEETS	STA.
				TO STA.

F.A.I. RTE.	SECTION	COUNTY	TOTAL SHEETS	SHEET NO.
55	2021-128-SG	VARIOUS	178	166
CONTRACT NO. 62P27				
ILLINOIS FED. AID PROJECT				

STRUCTURE NUMBER		1G022I055R272.0-000	
LOCATION		122 EXPRESSWAY	
SIZE (W x H)	EXIT PLAQUE	-	
	MAIN PANEL	14.5' X 10.5'	
MOUNTING / TYPE		GROUND	
MOUNTING LOC (L, M, R)		RIGHT	
SHEETING / COLOR	BACKGROUND	TYPE:	ZZ
		COLOR:	GREEN
		TYPE:	
		COLOR:	
	LEGEND / BORDER	TYPE:	ZZ
		COLOR:	WHITE
		TYPE:	
		COLOR:	



12.00" Radius, 2.00" Border, White on Green;  
 "Darrien", E Mod 2K; "Argonne Nat'l", E Mod 2K; "Laboratory", E Mod 2K; "EXIT 273A", E Mod 2K;  
 Table of widths and spaces

53.88	D	10.88	2.75	a	8.88	5.25	r	6.75	3.13	i	2.63	4.13	e	8.88	4.13	n	8.75	54.00												
2.00	170.00		2.00																											
14.50	A	13.38	3.25	r	6.63	2.00	g	8.88	4.13	o	9.00	4.13	n	8.88	5.25	n	8.88	4.13	e	8.75										
	N	13.38	10.75	3.38	a	8.75	3.88	t	6.88	2.25	2.63	3.13	l	2.75	14.38															
29.50	L	9.88	1.75	a	8.75	5.38	b	8.75	3.00	o	9.00	4.25	r	6.63	2.00	a	8.75	3.88	t	7.00	3.00	o	9.13	4.13	r	6.63	1.75	y	11.25	29.63
34.88	E	7.38	1.38	x	8.75	2.00	i	2.00	1.88	t	7.38	15.00	2	12.13	2.63	7	12.13	2.25	3	12.13	2.13	A	15.13	34.88						

MODEL: Default  
 FILE NAME: S:\V\Design\KKS\Signs\_Design\Contract-46556-Signs\_Structure-Design-155-and-1200-County-4-Enc-84-co-Water-Rd\CADD\62P27-155\_Signs-IP-KK-COMBINED-06-28-21.dwg  
 DATE: 7/1/2021

USER NAME = plascenciaj	DESIGNED - KK	REVISED -
DRAWN - KK / IP	REVISIONS	
PLOT SCALE = 40,0000 * / in.	CHECKED - LP	REVISED -
PLOT DATE = 7/1/2021	DATE - 06/25/2021	REVISED -

**STATE OF ILLINOIS**  
**DEPARTMENT OF TRANSPORTATION**

<b>SIGN PANEL DESIGN</b>			
SCALE:	SHEET	OF	SHEETS
	STA.		TO STA.

F.A.I. RTE.	SECTION	COUNTY	TOTAL SHEETS	SHEET NO.
55	2021-128-SG	VARIOUS	178	167
			CONTRACT NO. 62P27	
		ILLINOIS	FED. AID PROJECT	

STRUCTURE NUMBER		1G022I055R272.3-000	
LOCATION		123 EXPRESSWAY	
SIZE (W x H)	EXIT PLAQUE	-	
	MAIN PANEL	13' X 11'	
MOUNTING / TYPE		GROUND	
MOUNTING LOC (L, M, R)		RIGHT	
SHEETING / COLOR	BACKGROUND	TYPE:	ZZ
		COLOR:	GREEN
		TYPE:	
		COLOR:	
	LEGEND / BORDER	TYPE:	ZZ
		COLOR:	WHITE
		TYPE:	
		COLOR:	

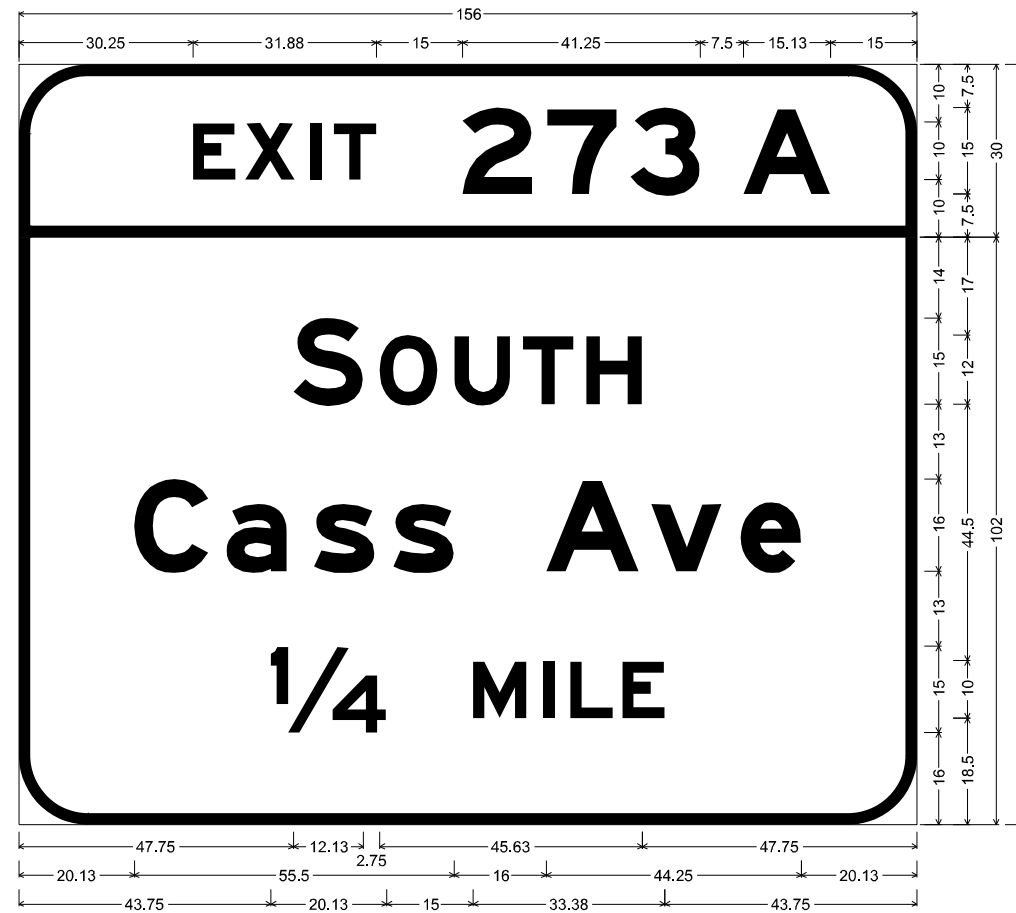

12.00" Radius, 2.00" Border, White on Green;  
 "EXIT", E Mod 2K 120% spacing; "273", E Mod 2K; "A", E Mod 2K;  
 12.00" Radius, 2.00" Border, White on Green;  
 "SOUTH", E Mod 2K; "Cass Ave", E Mod 2K; "1/4 MILE", E Mod 2K;

Table of widths and spaces

30.25	E	7.38	1.75	X	8.63	2.50	I	2.00	2.25	T	7.38	15.00	2	12.13	2.50	7	12.13	2.25	3	12.25	7.50	A	15.13	15.00
47.75	S	12.13	2.75	O	10.13	2.88	U	9.75	2.13	T	8.88	2.13	H	9.75	47.75									
20.13	C	12.88	3.13	a	10.50	4.63	s	10.63	3.13	s	10.63	16.00	A	16.13	2.00	v	12.38	3.25	e	10.50	20.13			
43.75	1/4	20.13	15.00	M	9.38	2.75	I	2.00	2.75	L	7.50	1.50	E	7.50	43.75									

MODEL: D:\p\p\Design\KKS\Signs - Design\Contract-46556-Signs-Structure-Design-155-and-1200-County-4-Enc-84-co-Wabor-Rd\CDD\62P27155\_Signs\csp-IP-KK-COM\BIBED-06-28-21.dwg  
 FILE NAME: S:\IP\Design\KKS\Signs - Design\Contract-46556-Signs-Structure-Design-155-and-1200-County-4-Enc-84-co-Wabor-Rd\CDD\62P27155\_Signs\csp-IP-KK-COM\BIBED-06-28-21.dwg

USER NAME = plascencjal	DESIGNED - KK	REVISED -
DRAWN - KK / IP	REVISOR -	
PLOT SCALE = 40,0000 * / in.	CHECKED - LP	REVISOR -
PLOT DATE = 7/1/2021	DATE - 06/25/2021	REVISOR -

**STATE OF ILLINOIS**  
**DEPARTMENT OF TRANSPORTATION**

**SIGN PANEL DESIGN**

SCALE: SHEET OF SHEETS STA. TO STA.

F.A.I. RTE.	SECTION	COUNTY	TOTAL SHEETS	SHEET NO.
55	2021-128-SG	VARIOUS	178	168
CONTRACT NO. 62P27			ILLINOIS FED. AID PROJECT	

STRUCTURE NUMBER		1G022I055R273.9-001	
LOCATION		124 EXPRESSWAY	
SIZE (W x H)	EXIT PLAQUE	-	
	MAIN PANEL	15.5' X 12.5'	
MOUNTING / TYPE		GROUND	
MOUNTING LOC (L, M, R)		RIGHT	
SHEETING / COLOR	BACKGROUND	TYPE:	ZZ
		COLOR:	GREEN
		TYPE:	
	LEGEND / BORDER	COLOR:	
		TYPE:	ZZ
		COLOR:	WHITE

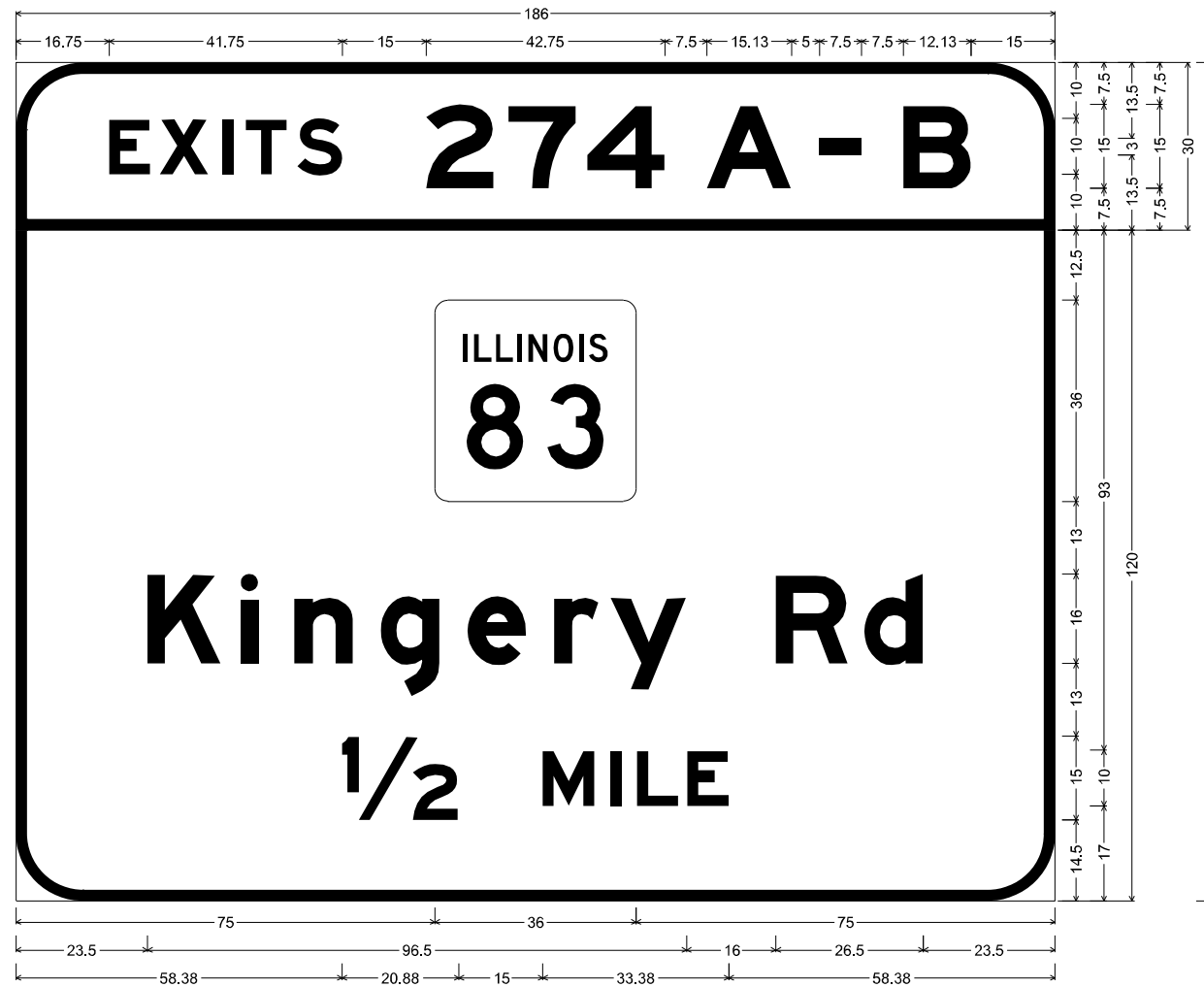

12.00" Radius, 2.00" Border, White on Green;  
 "EXITS", E Mod 2K 120% spacing; "274", E Mod 2K; "A", E Mod 2K; "B", E Mod 2K;

12.00" Radius, 2.00" Border, White on Green;  
 "Kingery Rd", E Mod 2K; "1/2 MILE", E Mod 2K;

Table of widths and spaces

E	X	I	T	S	Z	7	4	A	□	B													
16.75	7.38	1.63	8.75	2.50	2.00	2.13	7.38	1.88	8.00	15.00	12.25	2.50	12.13	2.00	13.88	7.50	15.25	5.00	7.50	7.50	12.13	15.00	
75.00	36.00	75.00																					
K	i	n	g	e	r	y	R	d															
23.50	13.13	3.63	3.13	6.38	10.63	4.88	10.63	4.88	10.63	5.00	8.00	2.00	13.63	16.00	13.00	2.88	10.50	23.63					
58.38	20.88	15.00	M	I	L	E																	
			9.38	2.75	2.00	2.88	7.38	1.63	7.38	58.38													

MODEL: D:\p\p\Design\KKS\Signs - Design\Contract-48556-Signs-Structure-Design-155-and-1200-County-4-Enc-84-co-Water-Rd\CADD\62P27-155\_Signs-IP-KK-COMBINED-06-28-21.dwg  
 FILE NAME: S:\IP\Design\KKS\Signs - Design\Contract-48556-Signs-Structure-Design-155-and-1200-County-4-Enc-84-co-Water-Rd\CADD\62P27-155\_Signs-IP-KK-COMBINED-06-28-21.dwg

USER NAME = plascencjal	DESIGNED - KK	REVISED -
DRAWN - KK / IP	REVISOR -	
PLOT SCALE = 40,0000 * / in.	CHECKED - LP	REVISOR -
PLOT DATE = 7/1/2021	DATE - 06/25/2021	REVISOR -

**STATE OF ILLINOIS  
DEPARTMENT OF TRANSPORTATION**

**SIGN PANEL DESIGN**

SCALE: SHEET OF SHEETS STA. TO STA.

F.A.I. RTE.	SECTION	COUNTY	TOTAL SHEETS	SHEET NO.
55	2021-128-SG	VARIOUS	178	169
CONTRACT NO. 62P27			ILLINOIS FED. AID PROJECT	

**DETAILS**

"TOLL" PLAQUE DETAIL DESIGN

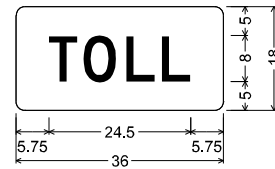

1.50" Radius, 0.00" Border, White on Yellow;

"TOLL" Black, D 2K;

Table of widths and spaces

	T	O	L	L	
5.75	4.88	1.13	5.63	1.75	5.00

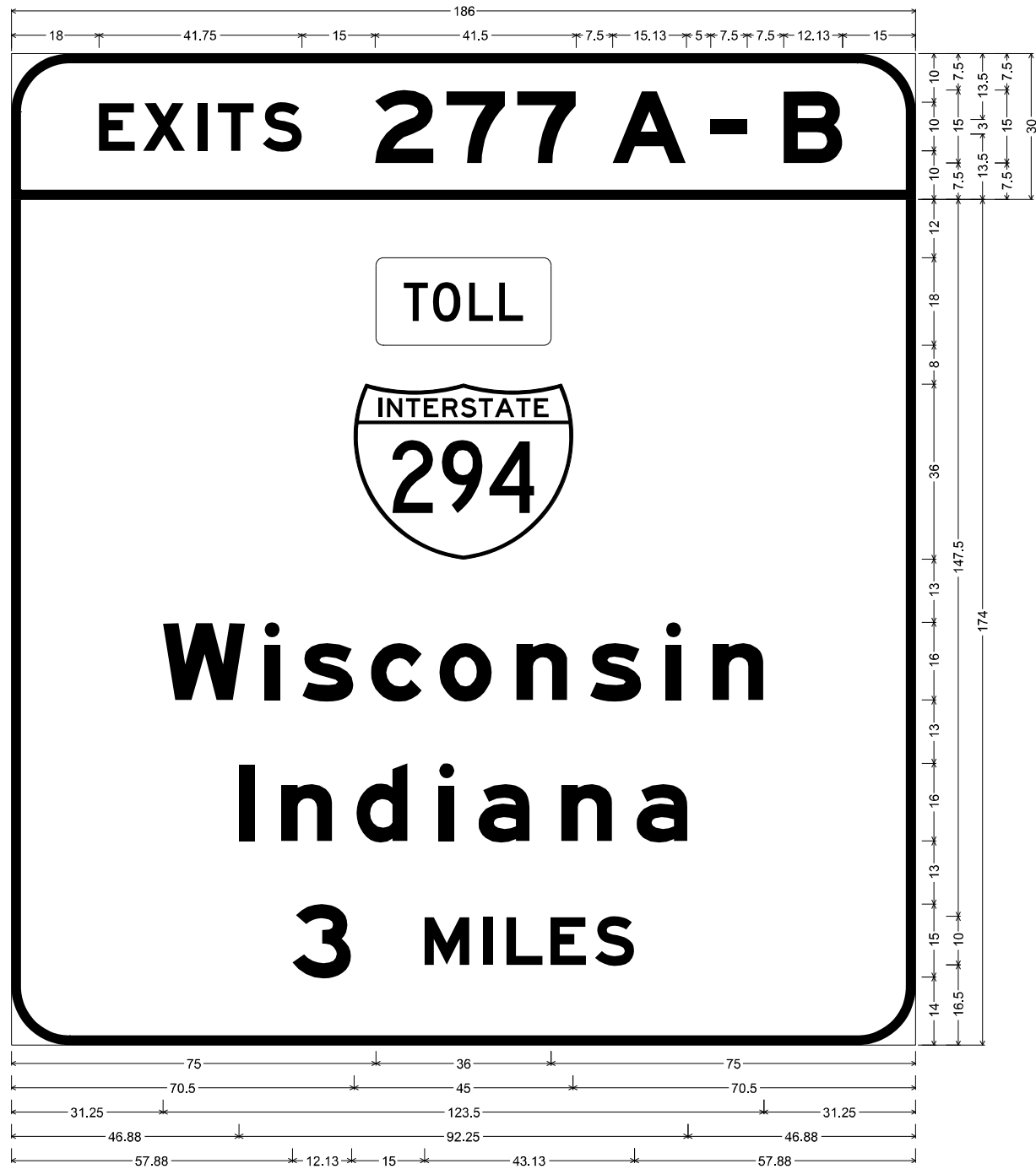

12.00" Radius, 2.00" Border, White on Green;  
 "EXITS", E Mod 2K 120% spacing; "277", E Mod 2K; "A", E Mod 2K; "B", E Mod 2K;

12.00" Radius, 2.00" Border, White on Green;  
 Rounded Rectangle 1.50" Radius Yellow;  
 "Wisconsin", E Mod 2K; "Indiana", E Mod 2K; "3 MILES", E Mod 2K;

Table of widths and spaces

18.00	7.50	1.63	8.75	2.50	2.00	2.13	7.38	1.75	8.13	15.00	12.13	2.63	12.13	2.38	12.13	7.50	15.13	5.00	7.50	7.50	12.25	15.00
75.00	36.00	75.00																				
70.50	45.00	70.50																				
31.25	17.00	3.75	3.25	4.63	10.50	3.63	10.50	3.50	10.88	5.00	10.50	4.75	10.50	5.00	3.13	6.38	10.63	31.25				
46.88	3.13	5.50	10.50	5.00	10.50	6.50	3.13	5.00	10.50	6.50	10.50	5.00	10.50	46.88								
57.88	12.13	15.00	9.25	2.88	1.88	2.88	7.38	1.63	7.38	1.75	8.13	57.88										

STRUCTURE NUMBER		1G022I055R274.0-000	
LOCATION		125 EXPRESSWAY	
SIZE (W x H)	EXIT PLAQUE	-	
	MAIN PANEL	15.5' X 17'	
MOUNTING / TYPE		GROUND	
MOUNTING LOC (L, M, R)		RIGHT	
SHEETING / COLOR	BACKGROUND	TYPE:	ZZ
		COLOR:	GREEN
		TYPE:	
	LEGEND / BORDER	TYPE:	ZZ
		COLOR:	WHITE
		COLOR:	

MODEL: D:\p\p\Design\KKS\Sigs Design\Contract-46546-Sigs-Structure-Design-155-and-1200-County-4-Enc-84-co-Wiscon-84-CDD\62P27-155\_Signage-IP-KK-COMBINED-06-28-21.dwg

USER NAME = plascencjal	DESIGNED - KK	REVISED -
PLOT SCALE = 40,0000 * / in.	DRAWN - KK / IP	REVISED -
PLOT DATE = 7/1/2021	CHECKED - LP	REVISED -
	DATE - 06/25/2021	REVISED -

**STATE OF ILLINOIS  
DEPARTMENT OF TRANSPORTATION**

**SIGN PANEL DESIGN**

SCALE: SHEET OF SHEETS STA. TO STA.

F.A.I. RTE.	SECTION	COUNTY	TOTAL SHEETS	SHEET NO.
55	2021-128-SG	VARIOUS	178	170
CONTRACT NO. 62P27			ILLINOIS FED. AID PROJECT	

STRUCTURE NUMBER		1G022I055R274.6-000	
LOCATION		126 EXPRESSWAY	
SIZE (W x H)	EXIT PLAQUE	-	
	MAIN PANEL	15' X 7.5'	
MOUNTING / TYPE		GROUND	
MOUNTING LOC (L, M, R)		RIGHT	
SHEETING / COLOR	BACKGROUND	TYPE:	ZZ
		COLOR:	GREEN
		TYPE:	
		COLOR:	
	LEGEND / BORDER	TYPE:	ZZ
		COLOR:	WHITE
		TYPE:	
		COLOR:	

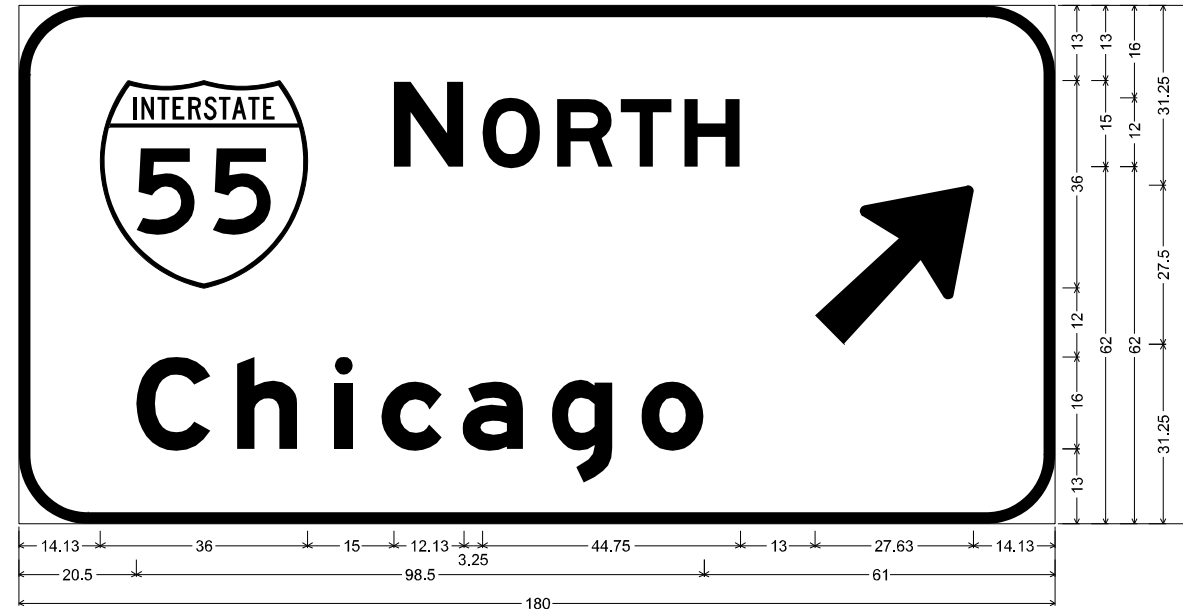

MODEL: D:\p\p\Design\KKS\Signs Design\Contract-46556-5\Sign-Structure-Design-155-and-1200-County-4-Enc-84-co-Water-Rd\CADD\62P27-155\_Signs\KKS-IP-KK-COMBINED-06-28-21.dwg  
 FILE NAME: S:\IP\Design\KKS\Signs Design\Contract-46556-5\Sign-Structure-Design-155-and-1200-County-4-Enc-84-co-Water-Rd\CADD\62P27-155\_Signs\KKS-IP-KK-COMBINED-06-28-21.dwg

USER NAME = plascencjal	DESIGNED - KK	REVISED -
	DRAWN - KK / IP	REVISED -
PLOT SCALE = 40,0000 * / in.	CHECKED - LP	REVISED -
PLOT DATE = 7/1/2021	DATE - 06/25/2021	REVISED -

**STATE OF ILLINOIS  
DEPARTMENT OF TRANSPORTATION**

**SIGN PANEL DESIGN**

SCALE: SHEET OF SHEETS STA. TO STA.

F.A.I. RTE.	SECTION	COUNTY	TOTAL SHEETS	SHEET NO.
55	2021-128-SG	VARIOUS	178	171
CONTRACT NO. 62P27				
ILLINOIS FED. AID PROJECT				

STRUCTURE NUMBER		1G022I055R275.7-000	
LOCATION		127	EXPRESSWAY
SIZE (W x H)	EXIT PLAQUE	-	
	MAIN PANEL	19' X 10.5'	
MOUNTING / TYPE		GROUND	
MOUNTING LOC (L, M, R)		RIGHT	
SHEETING / COLOR	BACKGROUND	TYPE:	ZZ
		COLOR:	GREEN
		TYPE:	
		COLOR:	
	LEGEND / BORDER	TYPE:	ZZ
		COLOR:	WHITE
		TYPE:	
		COLOR:	

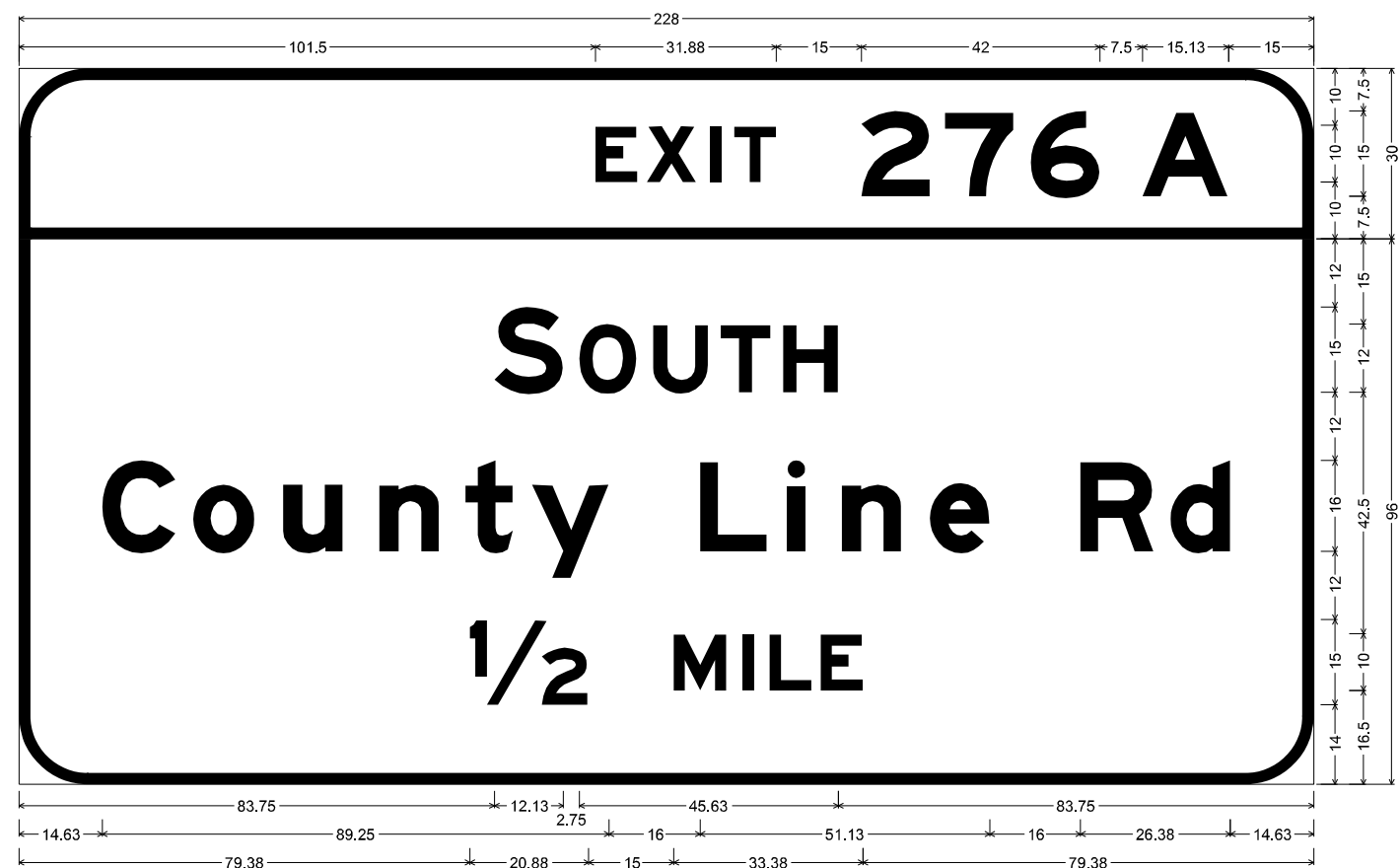

12.00" Radius, 2.00" Border, White on Green;  
 "EXIT", E Mod 2K 120% spacing; "276", E Mod 2K; "A", E Mod 2K;  
 12.00" Radius, 2.00" Border, White on Green;  
 "SOUTH", E Mod 2K; "County Line Rd", E Mod 2K; "1/2 MILE", E Mod 2K;

Table of widths and spaces

101.50	E	7.38	X	1.75	8.63	2.50	I	2.00	2.25	T	7.38	15.00	Z	12.13	2.50	7	12.13	3.00	6	12.25	7.50	A	15.13	15.00												
83.75	S	12.13	O	2.75	10.13	2.88	U	9.75	2.13	T	8.88	2.13	H	9.75	83.75																					
14.63	C	13.00	o	3.00	10.88	5.00	u	10.50	6.38	n	10.63	4.63	t	8.25	3.38	y	13.63	16.00	L	11.88	3.50	i	3.25	6.38	n	10.50	5.00	e	10.50	16.00	R	13.00	2.88	d	10.50	14.75
79.38	1/2	20.88	M	15.00	9.38	2.75	I	2.00	2.88	L	7.38	1.63	E	7.38	79.38																					

MODEL: D:\p\h  
 FILE NAME: S:\IP\Design\KKS\Signs Design\Contract-48556-Signs-Structure-Design-155-and-1200-County-Line-Rd-to-Western-Rd\CADD\62P27155\_Signs-IP-KK-COMBINED-06-28-21.dwg

USER NAME = plascencjal	DESIGNED - KK	REVISED -
DRAWN - KK / IP	REVISOR -	
PLOT SCALE = 40,0000 * / in.	CHECKED - LP	REVISED -
PLOT DATE = 7/1/2021	DATE - 06/25/2021	REVISED -

**STATE OF ILLINOIS  
DEPARTMENT OF TRANSPORTATION**

**SIGN PANEL DESIGN**

SCALE: SHEET OF SHEETS STA. TO STA.

F.A.I. RTE.	SECTION	COUNTY	TOTAL SHEETS	SHEET NO.
55	2021-128-SG	VARIOUS	178	172
CONTRACT NO. 62P27			ILLINOIS FED. AID PROJECT	



STRUCTURE NUMBER		1G0221055R276.2-001	
LOCATION		129A	EXPRESSWAY
SIZE (W x H)	EXIT PLAQUE	-	
	MAIN PANEL	22.5' X 8.5'	
MOUNTING / TYPE		GROUND	
MOUNTING LOC (L, M, R)		RIGHT	
SHEETING / COLOR	BACKGROUND	TYPE:	ZZ
		COLOR:	GREEN
		TYPE:	
	LEGEND / BORDER	COLOR:	
		TYPE:	ZZ
		COLOR:	WHITE

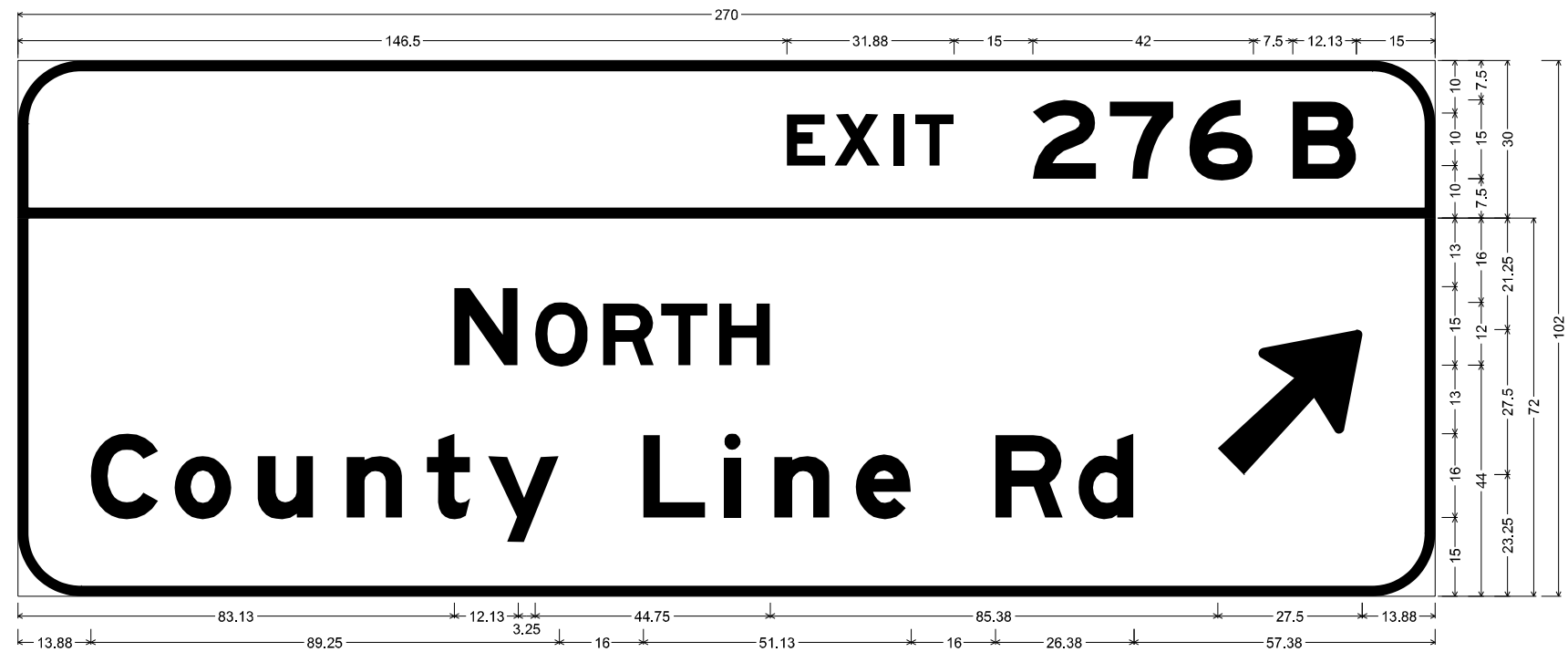

12.00" Radius, 2.00" Border, White on Green;  
 "EXIT", E Mod 2K 120% spacing; "276", E Mod 2K; "B", E Mod 2K;  
 12.00" Radius, 2.00" Border, White on Green;  
 "NORTH", E Mod 2K; "County Line Rd", E Mod 2K; Arrow 160 - 35.00" 45";  
 Table of widths and spaces

146.50	E	7.38	1.75	X	8.63	2.50	I	2.00	2.25	T	7.38	15.00	Z	12.13	2.50	7	12.13	3.00	6	12.25	7.50	B	12.13	15.00
83.13	N	12.13	3.25	O	10.13	2.88	R	9.75	1.25	T	8.88	2.25	H	9.63	85.38	27.50	13.88							
13.88	C	13.00	3.00	o	10.88	5.00	u	10.50	6.38	n	10.63	4.63	t	8.25	3.38	y	13.63	16.00	L	11.88	3.50	i	3.13	6.50

MODEL: D:\p\h\p\...  
 FILE NAME: S:\p\p\Design\KKS\Signs\_Design\Contract-46556-Signs\_Structure-Design-155\_and-1200-County-Line-Rd-44-cc-Webster-Rd\CDD\6127155\_Signs\KKS-IP-KK-COMBINED-06-28-21.dwg

USER NAME = plascencjal	DESIGNED - KK	REVISED -	<b>STATE OF ILLINOIS</b> <b>DEPARTMENT OF TRANSPORTATION</b>	<b>SIGN PANEL DESIGN</b>		F.A.I. RTE.	SECTION	COUNTY	TOTAL SHEETS	SHEET NO.
DRAWN - KK / IP	REVISED -	55				2021-128-SG	VARIOUS	178	173	
PLOT SCALE = 40,0000 * / in.	CHECKED - LP	REVISED -		SCALE: SHEET OF SHEETS STA. TO STA.		CONTRACT NO. 62P27				
PLOT DATE = 7/1/2021	DATE - 06/25/2021	REVISED -		ILLINOIS FED. AID PROJECT						

STRUCTURE NUMBER		1B022I055L269.8-002	
LOCATION		131 EXPRESSWAY	
SIZE (W x H)	EXIT PLAQUE	-	
	MAIN PANEL	6.5' X 5'	
MOUNTING / TYPE		OVERHEAD / BRIDGE	
MOUNTING LOC (L, M, R)			
SHEETING / COLOR	BACKGROUND	TYPE:	ZZ
		COLOR:	GREEN
		TYPE:	
	LEGEND / BORDER	COLOR:	
		TYPE:	ZZ
		COLOR:	WHITE

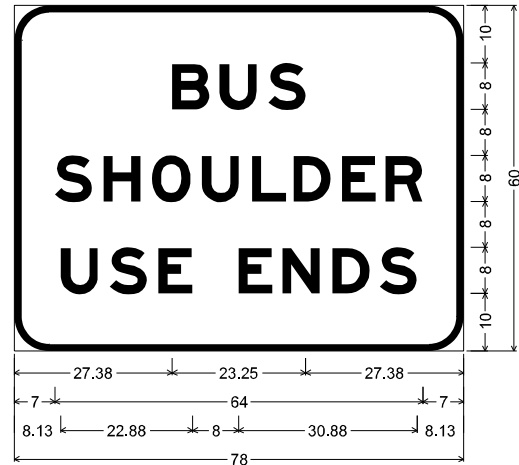

6.00" Radius, 1.25" Border, Black on White;  
 "BUS", E Mod 2K; "SHOULDER", E Mod 2K;  
 "USE ENDS", E Mod 2K;

Table of widths and spaces

	B		U		S															
27.38	6.50	1.75	6.50	2.00	6.50	27.38														
	S		H		O		U		L		D		E		R					
7.00	6.50	2.00	6.50	1.88	6.75	1.88	6.50	2.25	6.00	1.25	6.50	1.88	5.88	1.75	6.50	7.00				
	U		S		E															
8.13	6.38	2.00	6.50	2.00	6.00															
	E		N		D		S													
	8.00	5.88	1.63	6.50	2.25	6.50	1.63	6.50	8.13											

MODEL Path:\p  
 FILE NAME: S:\IP\Design\KKS\Signs Design\Contract-46556\Sign-Structure-Design-155-and-1200-County-Hwy-84-co-West-84-co-CADD\62P27-155\_Sign-Struc-IP-KK-COMBINED-06-28-21.dwg

USER NAME = plascenciaj	DESIGNED - KK	REVISED -
DRAWN - KK / IP	REVISIONS -	
PLOT SCALE = 40,0000 * / in.	CHECKED - LP	REVISED -
PLOT DATE = 7/1/2021	DATE - 06/25/2021	REVISED -

**STATE OF ILLINOIS  
 DEPARTMENT OF TRANSPORTATION**

**SIGN PANEL DESIGN**

SCALE: SHEET OF SHEETS STA. TO STA.

F.A.I. RTE.	SECTION	COUNTY	TOTAL SHEETS	SHEET NO.
55	2021-128-SG	VARIOUS	178	174
CONTRACT NO. 62P27				
ILLINOIS FED. AID PROJECT				

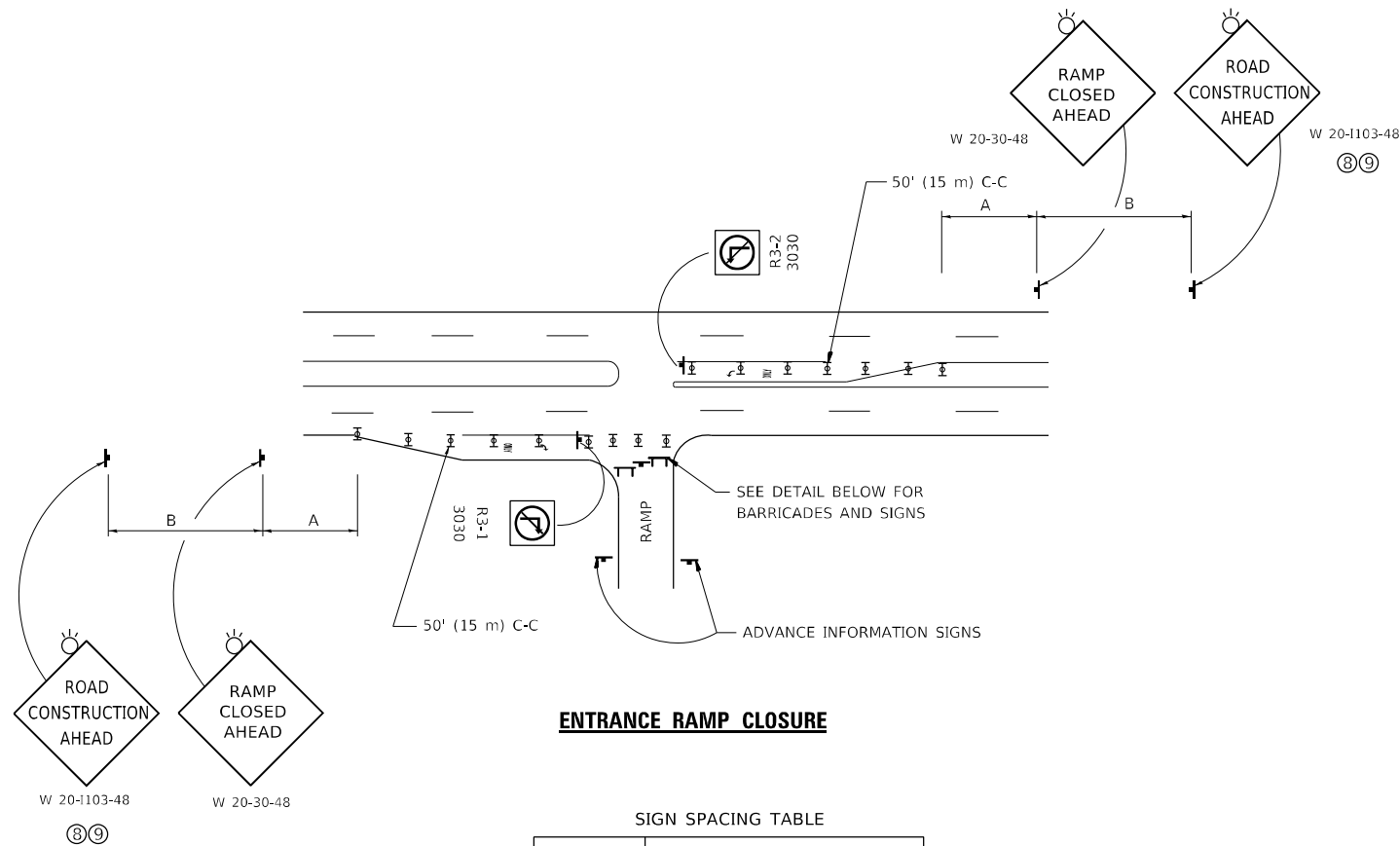

**ENTRANCE RAMP CLOSURE**

SIGN SPACING TABLE

FACILITY	DISTANCE BETWEEN SIGNS	
	A	B
EXPRESSWAY >24 HOURS	1000' (300 m)	1500' (450 m)
EXPRESSWAY ≤24 HOURS	500' (150 m)	500' (150 m)
ARTERIAL 55 MPH	500' (150 m)	500' (150 m)
ARTERIAL 50-45 MPH	350' (100 m)	350' (100 m)
ARTERIAL <45 MPH	200' (60 m)	200' (60 m)

DISTANCES MAY BE SHORTENED DEPENDING UPON THE PROXIMITY OF ADJACENT RAMPS OR INTERSECTIONS.

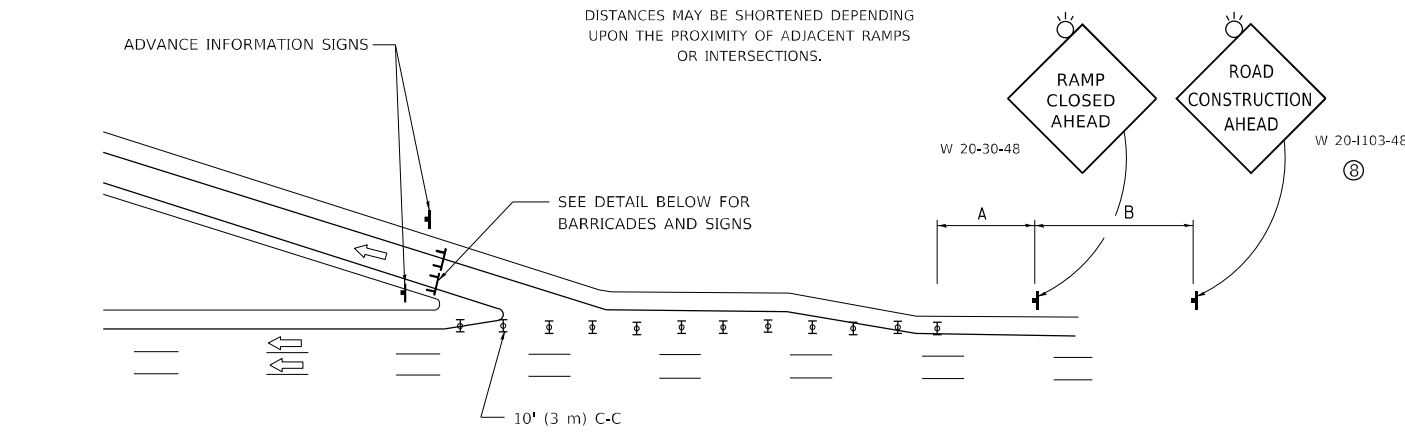

**EXIT RAMP CLOSURE**

**SYMBOLS**

- ☐ TYPE II BARRICADE OR DRUM
- ☐ TYPE III BARRICADE WITH 2 FLASHING LIGHTS

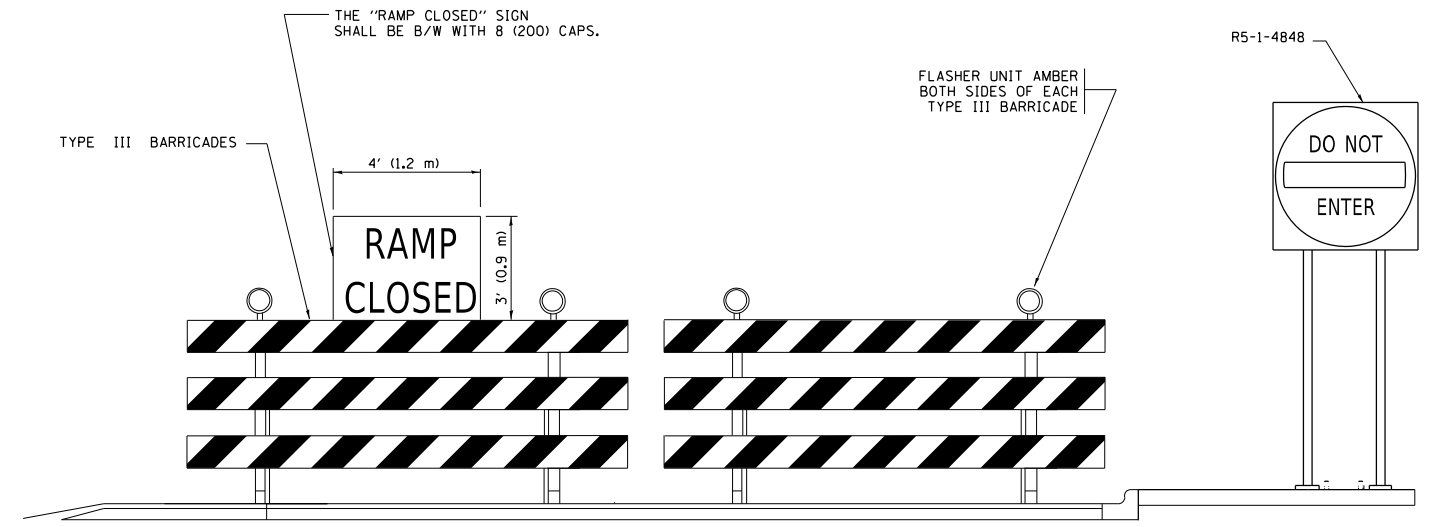

**DETAIL FOR REQUIRED BARRICADES & SIGNS**

**RAMP CLOSURE ADVANCE WARNING SIGN**

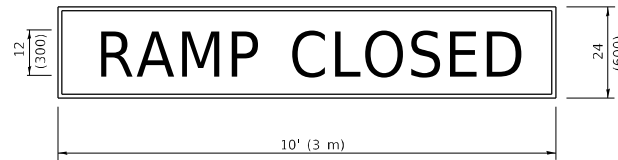

BLACK LEGEND ON ORANGE BACKGROUND MOUNTED DIAGONALLY  
E MOD FONT  
1 (25) BORDER

THESE SIGNS ARE REQUIRED ON ALL THE EXIT GUIDE SIGNS FOR EXIT RAMPS THAT WILL BE CLOSED FOR MORE THAN FOUR (4) CONSECUTIVE DAYS.

**RAMP CLOSURE ADVANCE INFORMATION SIGN**

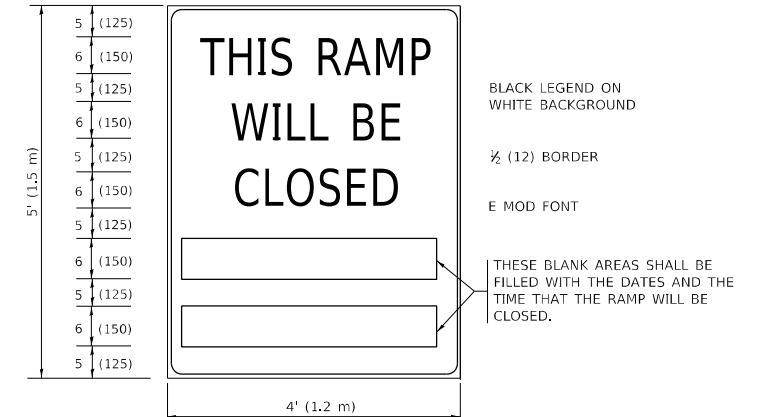

THESE SIGNS ARE REQUIRED ON BOTH SIDES OF THE RAMP, MINIMUM OF 1 WEEK IN ADVANCE OF THE CLOSURE.

THESE SIGNS SHALL BE FABRICATED AND PAID FOR ACCORDING TO THE TEMPORARY INFORMATION SIGNING SPECIAL PROVISION

**GENERAL NOTES:**

- ① CONES MAY BE SUBSTITUTED FOR DRUMS OR TYPE II BARRICADES DURING DAY OPERATIONS. CONES SHALL BE A MINIMUM OF 28 (700) HIGH.
- ② VERTICAL BARRICADES SHALL NOT BE USED FOR RAMP CLOSURES.
- ③ A FLAGGER SHALL BE POSITIONED AT EACH CLOSED RAMP THAT IS OPEN TO CONSTRUCTION VEHICLES, PRECEDED BY A W20-7 FLAGGER WARNING SIGN.
- ④ ALL ROUTE MARKERS AND TRAILBLAZER ASSEMBLIES WHICH DIRECT MOTORISTS TO A CLOSED ENTRANCE RAMP SHALL BE COVERED WHEN THE RAMP IS CLOSED FOR MORE THAN FOUR (4) DAYS.
- ⑤ THE SIGNING AND BARRICADING WHICH IS REQUIRED BY THIS DETAIL SHALL BE INCLUDED IN THE COST OF TRAFFIC CONTROL AND PROTECTION (EXPRESSWAYS).
- ⑥ AUTHORIZATION FROM THE DISTRICT'S BUREAU OF TRAFFIC IS REQUIRED FOR ALL RAMP CLOSURES.
- ⑦ THE RAMP CLOSURE ADVANCE INFORMATION SIGNS SHALL BE ERECTED IF THE CLOSURE TIME EXCEEDS TWENTY-FOUR (24) HOURS. ADDITIONAL ADVANCE WARNING SIGNS ON EXIT GUIDE SIGNING WILL BE REQUIRED FOR EXIT RAMP CLOSURES THAT EXCEED FOUR (4) DAYS IN LENGTH
- ⑧ ROAD CONSTRUCTION AHEAD SIGNS MAY BE OMITTED WHEN THIS DETAIL IS USED IN CONJUNCTION WITH OTHER TRAFFIC CONTROL THAT ALREADY INCLUDES A ROAD CONSTRUCTION AHEAD SIGN.
- ⑨ ARTERIAL ROAD CONSTRUCTION AHEAD SIGNS SHALL BE INSTALLED ON THE LEFT SIDE OF TRAFFIC IF THE MEDIAN IS MORE THAN 10 FT WIDE.

ALL DIMENSIONS ARE IN INCHES (MILLIMETERS) UNLESS OTHERWISE SHOWN.

MODEL: Default  
FILE NAME: S:\WP\Design\Ibvan10\_Signs\6727\_145\_Signage\CADD\6727\_145-general.dgn

USER NAME = plascencia	DESIGNED - D.W.S.	REVISED - S.P.B._01-07
PLOT SCALE = 100,0000' / in.	CHECKED -	REVISED - S.P.B._12-09
PLOT DATE = 7/1/2021	DATE - 02-83	REVISED - M.D._06-13
		REVISED - M.D._01-18

**STATE OF ILLINOIS  
DEPARTMENT OF TRANSPORTATION**

**ENTRANCE\_AND\_EXIT\_RAMP  
CLOSURE\_DETAILS**

SCALE: NONE SHEET 1 OF 1 SHEETS STA. TO STA.

F.A.I. RTE.	SECTION	COUNTY	TOTAL SHEETS	SHEET NO.
55	2021-128-SG	VARIOUS	178	175
<b>TC-08</b>			CONTRACT NO. 62P27	
		ILLINOIS	FED. AID PROJECT	

# SINGLE LANE WEAVE

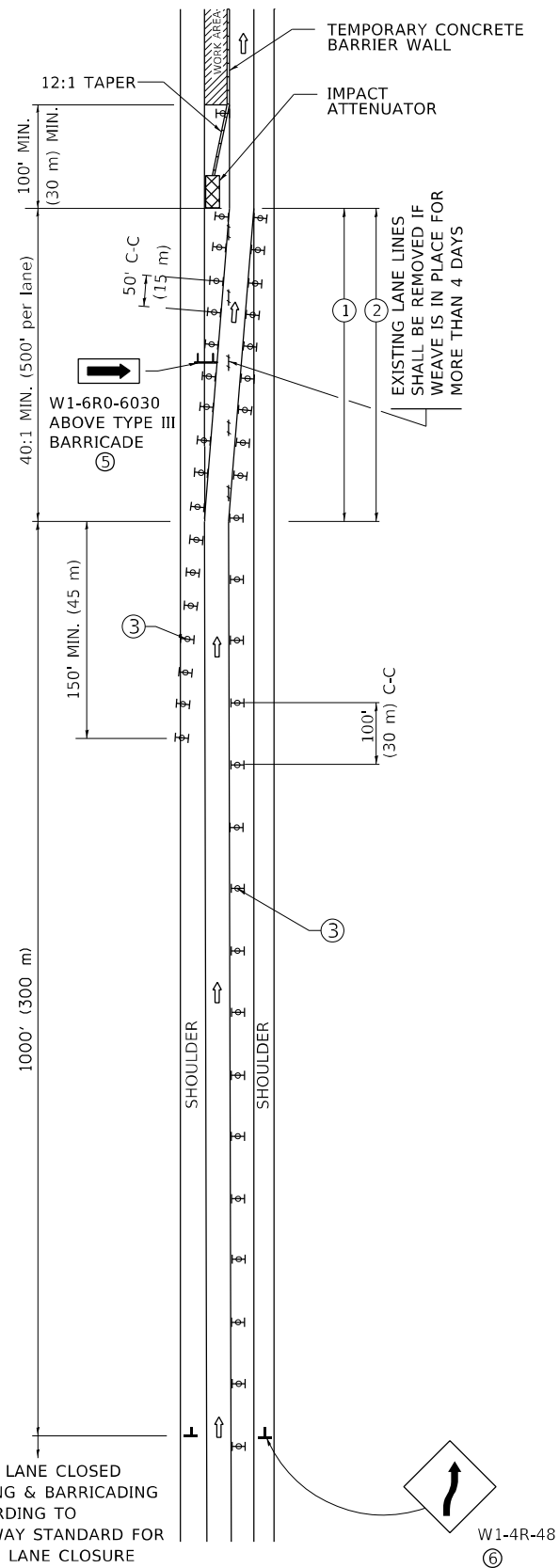

# MULTI-LANE WEAVE

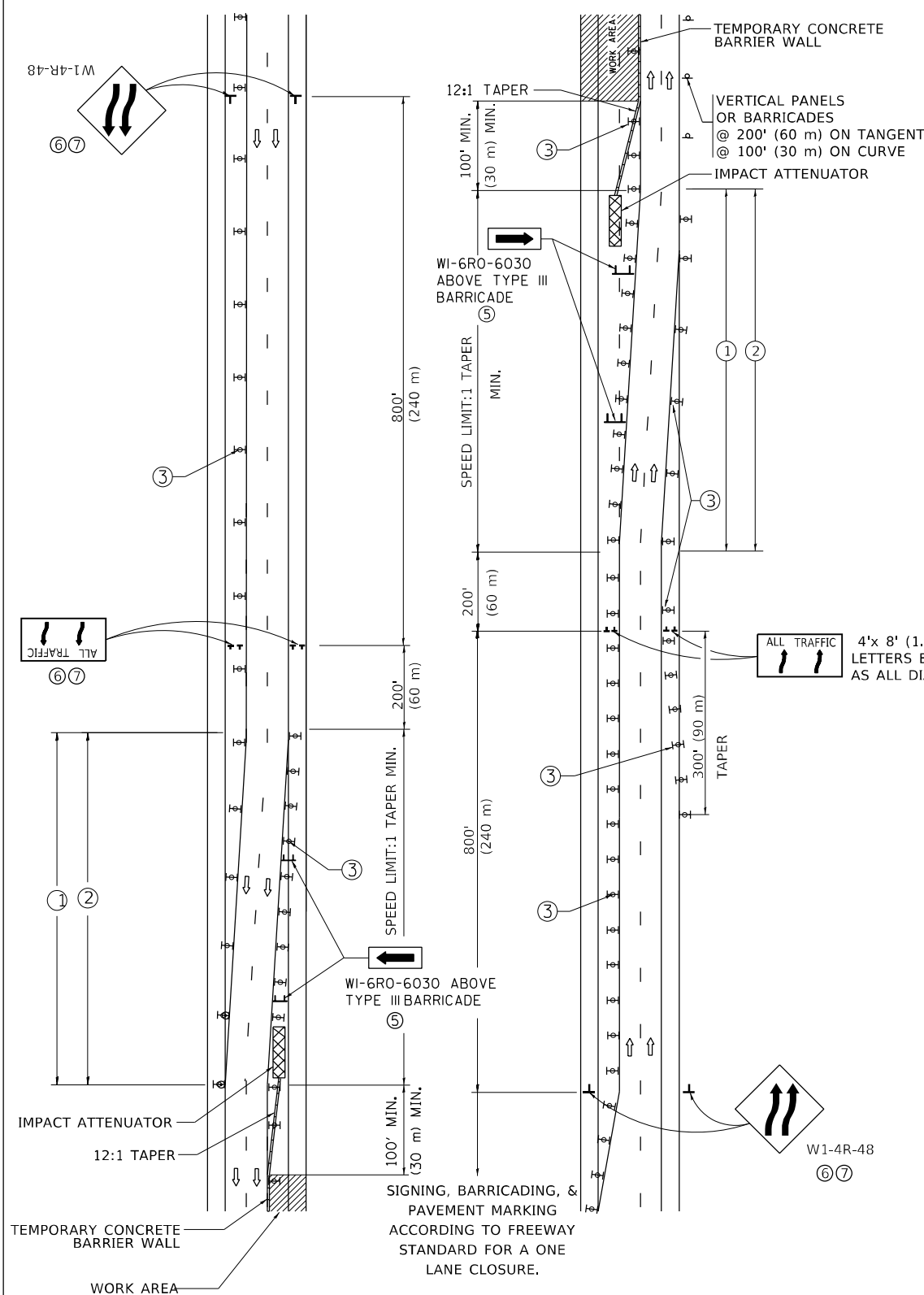

### GENERAL NOTES:

- ① EXISTING CONFLICTING PAVEMENT MARKING LINES SHALL BE REMOVED. PAVEMENT MARKING REMOVAL SHALL NOT BE REQUIRED FOR SINGLE LANE WEAVES UNDER 4 DAYS IN DURATION.
- ② CONTINUOUS REFLECTIVE TEMPORARY PAVEMENT MARKING TAPE SHALL BE PLACED THROUGHOUT THE TAPER AND FOR 300' (90 m) ALONG SIDE THE WORK AREA WHERE THE CLOSURE TIME IS GREATER THAN FOURTEEN DAYS. THE LEFT EDGE LINE SHALL BE YELLOW AND THE RIGHT EDGE LINE SHALL BE WHITE. FOR MULTI-LANE WEAVES LANE LINES SHALL BE 5 INCH, 10'-30' (3 m-9 m) SKIP DASH, WHITE.
- ③ PLASTIC DRUMS WITH STEADY BURN LIGHTS AT 50' (15 m) C-C SPACING IN TAPERS AND 100' (30 m) C-C SPACING IN TANGENTS.
- ④ ALL SIGNS SHALL BE POST MOUNTED IF THE CLOSURE TIME EXCEEDS FOUR DAYS.
- ⑤ TYPE III BARRICADES MAY BE OMITTED FOR SINGLE-LANE WEAVES UNDER 24-HOURS IN DURATION. W1-6 SIGNS WILL STILL BE REQUIRED. IF THE WIDTH OF OFFSET IS LESS THAN 6' THEN THE TYPE III BARRICADE WITH ATTACHED ARROW SIGN PANEL CAN BE ELIMINATED IN THE TAPER AREAS.
- ⑥ WHEN THE LENGTH OF THE SHIFTED SEGMENT (DISTANCE BETWEEN WEAVE POINTS) IS LESS THAN 1500', DOUBLE REVERSE CURVE SIGNS (W24-1) SHOULD BE USED INSTEAD OF THE REVERSE CURVE (W1-4) SIGNS. ARROWS ON THE 4'X8' "ALL TRAFFIC" SIGNS SHALL BE THE SAME SHAPE.
- ⑦ THE NUMBER OF ARROWS ON THESE SIGNS SHALL MATCH THE NUMBER OF LANES OPEN TO TRAFFIC.

### SYMBOLS

- DIRECTION OF TRAFFIC
- WORK AREA
- SIGN ON PORTABLE OR PERMANENT SUPPORT
- TYPE II BARRICADE OR DRUM WITH MONO-DIRECTIONAL STEADY BURNING LIGHT
- TEMPORARY CONCRETE BARRIER WALL
- IMPACT ATTENUATOR
- W1-4R-48
- W24-1-48

ALL DIMENSIONS ARE IN INCHES (MILLIMETERS) UNLESS OTHERWISE SHOWN

MODEL: D:\p\h\... FILE NAME: SWIP\Design\Drawn10\_Signs\62P27\_545\_Signage\CADD\62P27\_sht-general.dgn

USER NAME = plascencal	DESIGNED - D.W.S.	REVISED - J.A.F. 02-06
	DRAWN -	REVISED - S.P.B. 01-07
PLOT SCALE = 100,000' / in.	CHECKED -	REVISED - S.P.B. 12-09
PLOT DATE = 7/1/2021	DATE - 02-87	REVISED - M.D. 06-13

STATE OF ILLINOIS  
DEPARTMENT OF TRANSPORTATION

TRAFFIC CONTROL DETAILS FOR  
FREEWAY SINGLE & MULTI-LANE WEAVE

SCALE: NONE SHEET 1 OF 1 SHEETS STA. TO STA.

F.A.I. RTE.	SECTION	COUNTY	TOTAL SHEETS	SHEET NO.
55	2021-128-SG	VARIOUS	178	176
TC-09			CONTRACT NO. 62P27	
ILLINOIS FED. AID PROJECT				

**PARTIAL RAMP CLOSURE DETAILS**

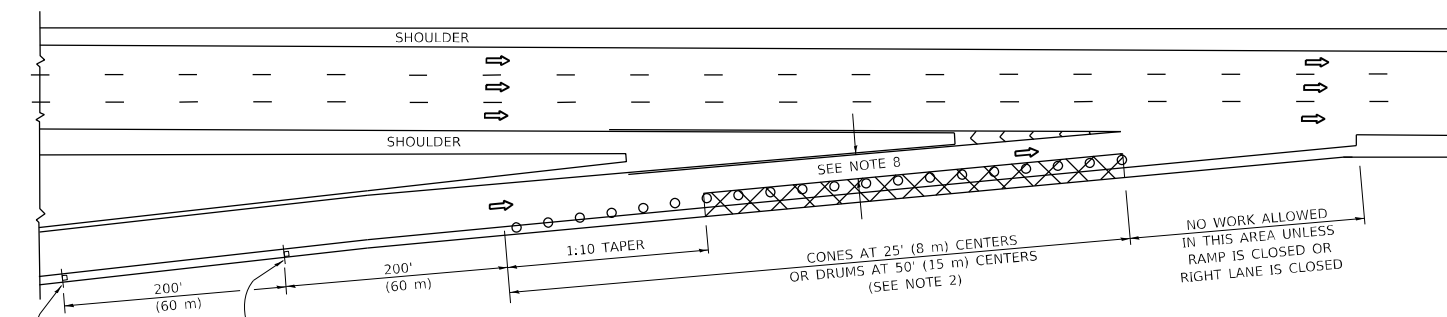

**TYPICAL ENTRANCE RAMP**

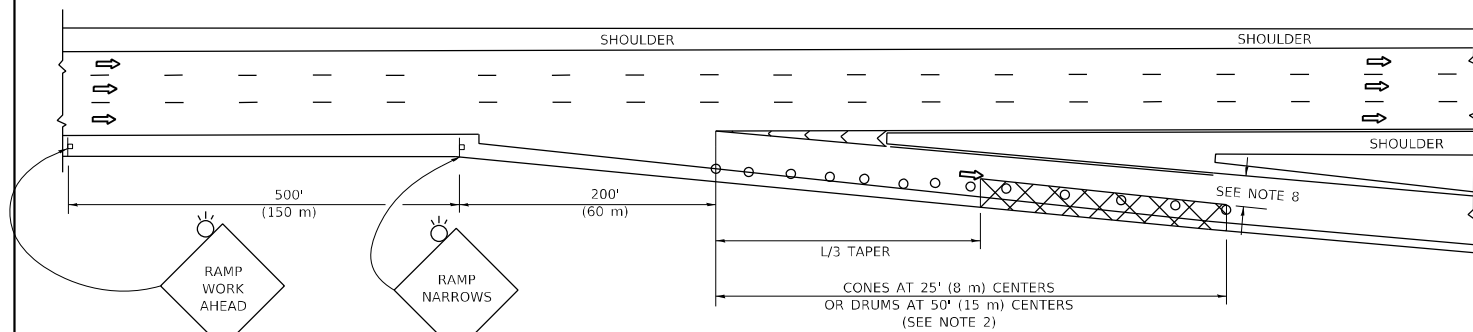

**TYPICAL EXIT RAMP**

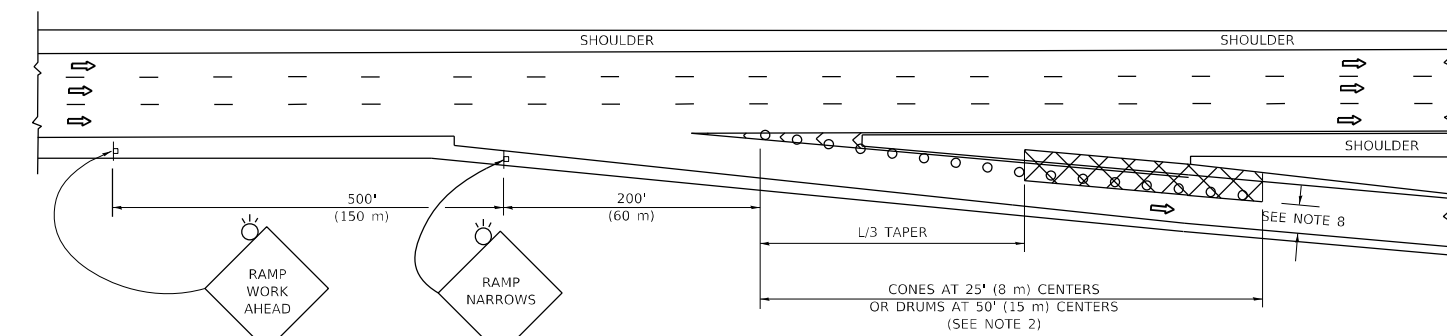

**TYPICAL EXIT RAMP**

**SYMBOLS**

- ACTIVE WORK AREA
- SIGN ON PORTABLE OR PERMANENT SUPPORT
- FLAGGER WITH CONTROL SIGN
- TYPE II BARRICADE OR DRUM
- CONE, DRUM OR BARRICADE
- IMPACT ATTENUATOR OF TYPE AND TEST LEVEL SPECIFIED

**GENERAL NOTES:**

1. THE "L" DISTANCE EQUALS:  

$L = \frac{W \cdot S}{S - V}$	$L = \frac{W \cdot S}{S - V}$	$L = \frac{W \cdot S}{S - V}$
45 mph (80 km/h) OR GREATER:	METRIC	ENGLISH
	$L = 0.65(W/S)$	$L = (W/S)$

W = WIDTH OF OFFSET IN FEET (METERS)  
 S = NORMAL POSTED SPEED MPH (KM/H)
2. TYPE II BARRICADES OR DRUMS ARE REQUIRED FOR ALL NIGHTTIME CLOSURES. TYPE II BARRICADES OR DRUMS WITH MONODIRECTIONAL STEADY BURN LIGHTS ARE REQUIRED FOR DELINEATING OBSTACLES, EXCAVATIONS, OR HAZARDS EXCEEDING 100 FT (30m) IN LENGTH AT NIGHT.
3. ALL SIGNS SHALL BE POST MOUNTED IF THE CLOSURE TIME EXCEEDS FOUR DAYS.
4. FLASHING LIGHTS SHALL BE USED DURING THE HOURS OF DARKNESS AND SHALL BE INSTALLED ABOVE THE FIRST TWO SETS OF SIGNS.

**SHOULDER CLOSURE DETAILS**

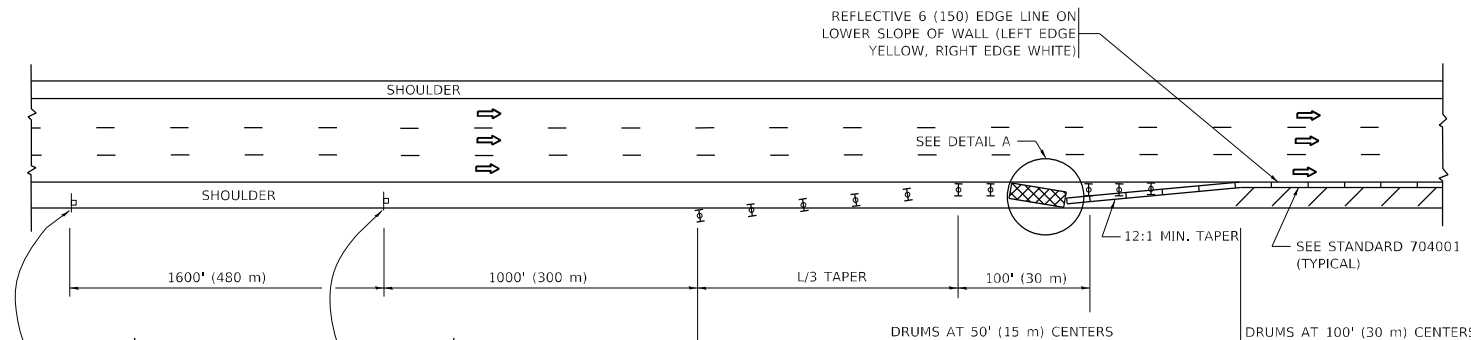

**PERMANENT SHOULDER CLOSURE**

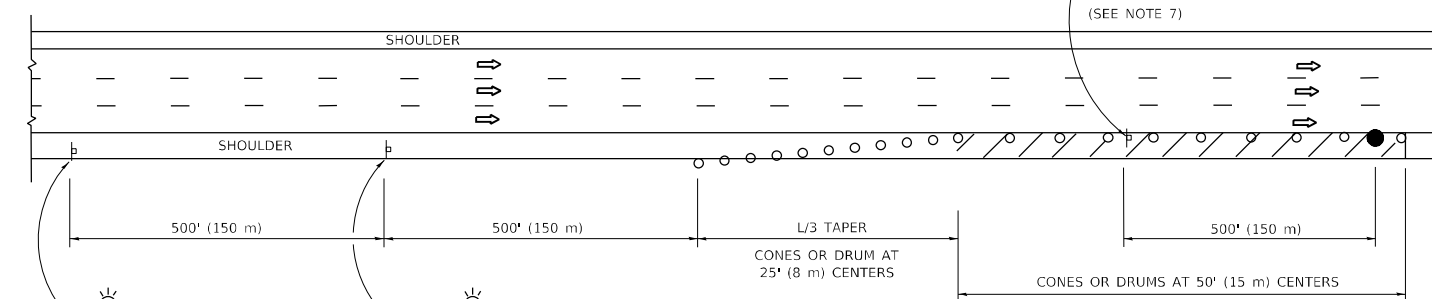

**TEMPORARY SHOULDER CLOSURE**

- THIS DETAIL IS USED WHERE:
1. VEHICLES, EQUIPMENT, WORKERS OR THEIR ACTIVITIES ENCR OACH IN AN AREA CLOSER THAN 15' (4.5 m) TO THE EDGE OF PAVEMENT FOR A PERIOD IN EXCESS OF 15 MINUTES.



**DETAIL "A"  
IMPACT ATTENUATOR, TEMPORARY  
(SEE NOTE 5)**

5. THE IMPACT ATTENUATOR, TEMPORARY IS NOT REQUIRED WHEN THE TEMPORARY CONCRETE BARRIER WALL IS PROTECTED BY OR IS TIED INTO THE EXISTING GUARDRAIL. IF OFFSET IS LESS THAN 5 FEET USE NARROW USE TYPE DEVICE TO MEET NCHRP350/MASH.
6. AUTHORIZATION FROM THE DISTRICT'S BUREAU OF TRAFFIC IS REQUIRED FOR ALL FREEWAY CLOSURES.
7. THE FLAGGER AND FLAGGER SIGN ARE REQUIRED AT THE ABOVE WORK SITES WHEN:
  - a. FOUR OR MORE WORK VEHICLES ENTER THE TRAFFIC LANES IN A ONE HOUR PERIOD.
  - b. THE WORK AVTIVITY REQUIRES FREQUENT ENCR OACHMENT INTO THE LANE OPEN TO TRAFFIC.
 THE FLAGGER SHALL BE STATIONED APPROXIMATELY 100' (30 m) TO 200' (60 m) IN ADVANCE OF THE WORKERS.
8. 12' MIN. WIDTH TANGENT SECTION  
16' MIN. WIDTH CURVE SECTION.
9. TEMPORARY SHOULDER AND NON-SYSTEM INTERCHANGE PARTIAL RAMP CLOSURES ARE ALLOWED WEEKDAYS BETWEEN 9:00 A.M. AND 3:00 P.M. AND BETWEEN 7:00 P.M. AND 5:00 A.M. OR AS APPROVED BY THE EXPRESSWAY TRAFFIC OPERATIONS ENGINEER. PERMANENT SHOULDER AND PARTIAL RAMP CLOSURES WILL ONLY BE PERMITTED IF CALLED FOR IN THE PLANS OR AS APPROVED BY THE EXPRESSWAY OPERATIONS ENGINEER.

ALL DIMENSIONS ARE IN INCHES (MILLIMETERS) UNLESS OTHERWISE SHOWN.

MODEL: Default  
FILE NAME: SWIPDesign\boan10\_Spinns63727\_545\_Signage\CADD\62P27-2ht-general.dgn

USER NAME = plascencia	DESIGNED -	REVISED - S.P.B. 12-09
	DRAWN - D.W.S.	REVISED - M.D. 06-13
PLOT SCALE = 100,0000' / in.	CHECKED -	REVISED - M.D. 01-18
PLOT DATE = 7/1/2021	DATE - 11-96	REVISED - M.D. 10-20

**STATE OF ILLINOIS  
DEPARTMENT OF TRANSPORTATION**

**TRAFFIC CONTROL DETAILS FOR FREEWAY  
SHOULDER CLOSURES AND PARTIAL RAMP CLOSURES**

SCALE: NONE SHEET 1 OF 1 SHEETS STA. TO STA.

F.A.I. RTE.	SECTION	COUNTY	TOTAL SHEETS	SHEET NO.
55	2021-128-SG	VARIOUS	178	177
TC-17			CONTRACT NO. 62P27	
ILLINOIS FED. AID PROJECT				

**SIDE VIEW**

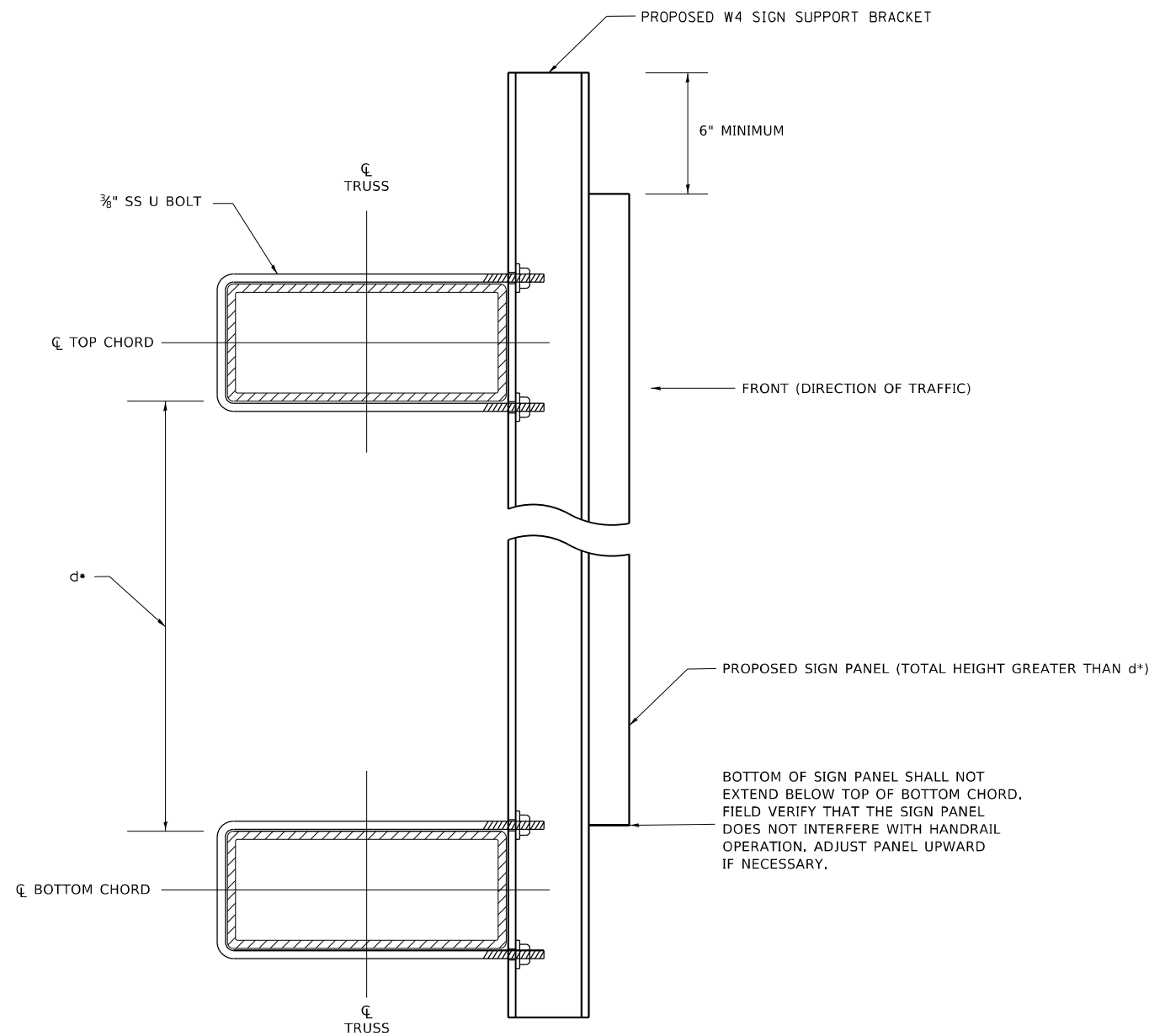

BOTTOM OF SIGN PANEL SHALL NOT EXTEND BELOW TOP OF BOTTOM CHORD. FIELD VERIFY THAT THE SIGN PANEL DOES NOT INTERFERE WITH HANDRAIL OPERATION. ADJUST PANEL UPWARD IF NECESSARY.

d\* - CLEAR SPAN BETWEEN TOP AND BOTTOM CHORDS

NOT TO SCALE

**TOP VIEW**

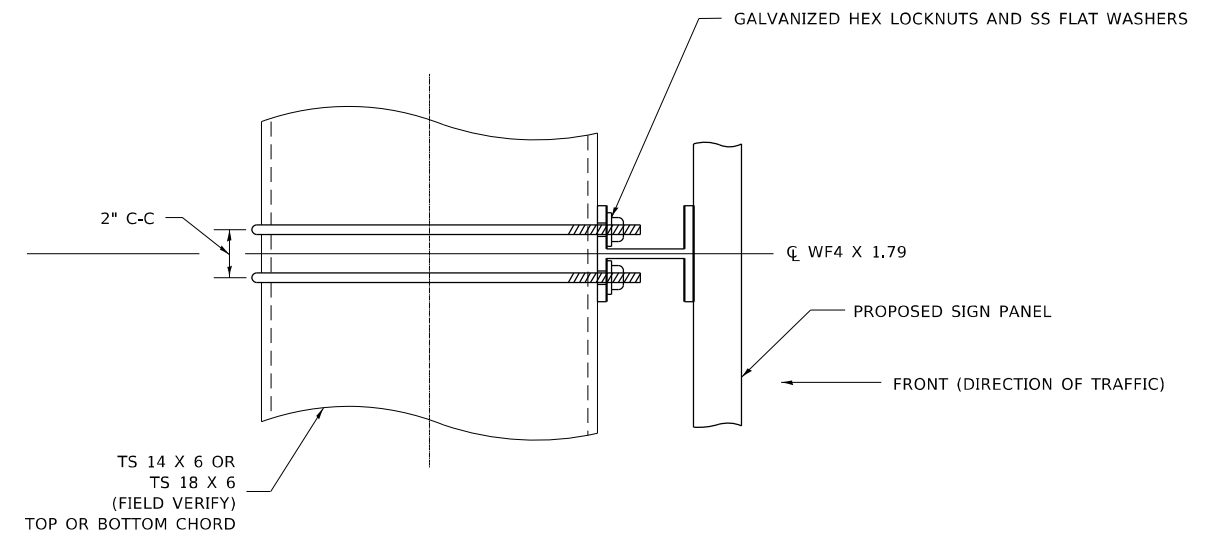

**BRACKET TABLE**

WF(A-N)4x1.79 ASTM B308, ALLOY 6061-T6		
SIGN WIDTH		NUMBER BRACKETS REQUIRED
GREATER THAN	LESS THAN OR EQUAL TO	
	8'-0"	2
8'-0"	14'-0"	3
14'-0"	20'-0"	4
20'-0"	26'-0"	5
26'-0"	32'-0"	6

**NOTES:**

1. CONTRACTOR SHALL FIELD VERIFY ALL DIMENSIONS PRIOR TO FABRICATION.
2. PROPOSED SIGN SUPPORT BRACKETS ARE REQUIRED FOR SIGN PANELS WITH ANY SEGMENT HEIGHT EXCEEDING d\*.
3. THE ENTIRE HEIGHT OF ANY SIGN PANEL SEGMENT SHALL BE FULLY SUPPORTED.
4. SPACING OF PROPOSED SIGN SUPPORT BRACKETS SHALL BE PER BRACKET TABLE WITH A MAXIMUM C-C DISTANCE OF 6'-0"
5. SIGN PANELS OF VARYING SEGMENT HEIGHTS SHALL HAVE A MINIMUM OF TWO (2) SUPPORT BRACKETS PER SEGMENT.

MODEL: D:\p\h\p\Drawings\10\_Signs\62P27\_145\_Signage\CADD\62P27\_145-general.dgn

USER NAME = plascenciaj	DESIGNED - M. MULLER	REVISED -
	DRAWN - G. DRIVAKOS	REVISED -
PLOT SCALE = 100,0000' / in.	CHECKED -	REVISED -
PLOT DATE = 7/1/2021	DATE - 10-01-15	REVISED -

**STATE OF ILLINOIS  
DEPARTMENT OF TRANSPORTATION**

**OVERHEAD SIGN STRUCTURE SUPPORT DETAIL FOR SIGN PANELS  
EXCEEDING HEIGHT IF EXISTING TRUSS**

SCALE: NONE SHEET 1 OF 1 SHEETS STA. TO STA.

F.A.I. RTE.	SECTION	COUNTY	TOTAL SHEETS	SHEET NO.
55	2021-128-SG	VARIOUS	178	178
<b>TC 32</b>			CONTRACT NO. 62P27	
ILLINOIS FED. AID PROJECT				