

STATE OF ILLINOIS
DEPARTMENT OF TRANSPORTATION

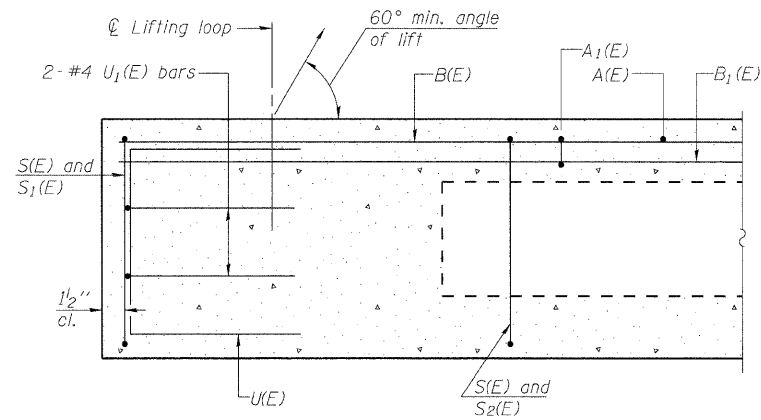

SECTION C-C

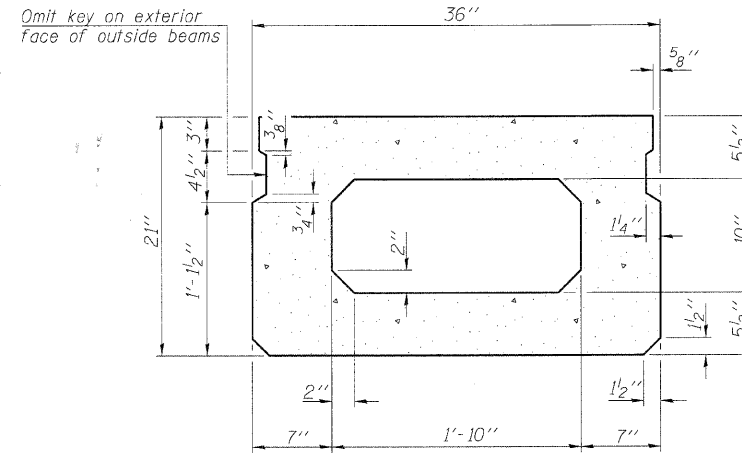

SECTION A-A
(Showing dimensions)

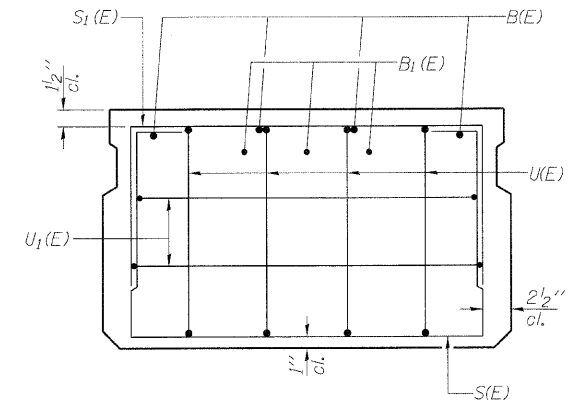

VIEW B-B

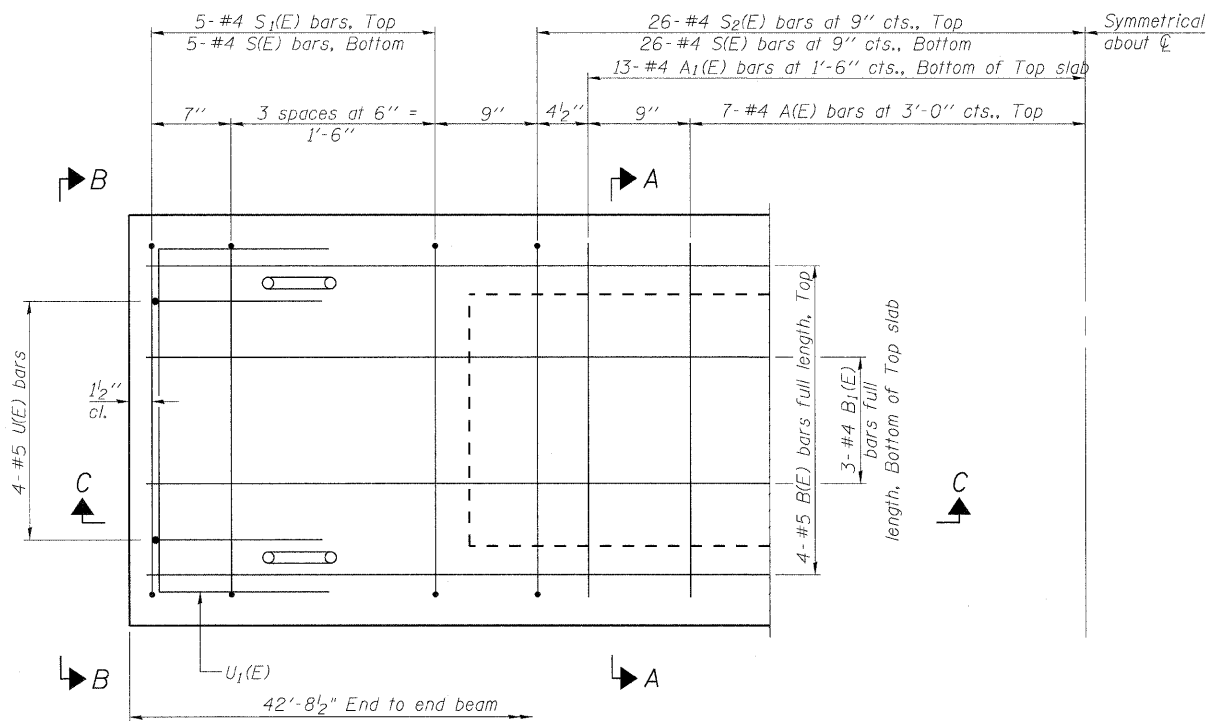

PLAN VIEW

Note: Spacing of S(E) and S2(E) bars may be adjusted up to 4" in the immediate area of the transverse tie diaphragms to miss the block outs for the transverse ties.

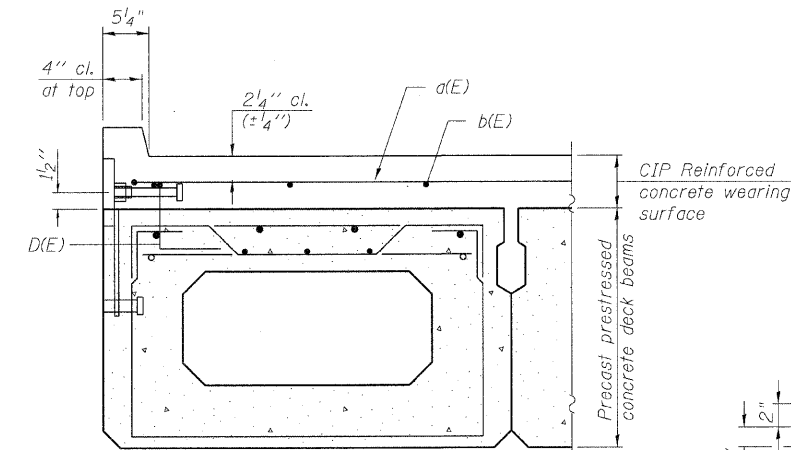

SECTION THRU EXTERIOR BEAM

See Typical Section Thru Interior Beam for strand pattern, dimensions and bar call outs. CWS and Curb shall be poured in the field.

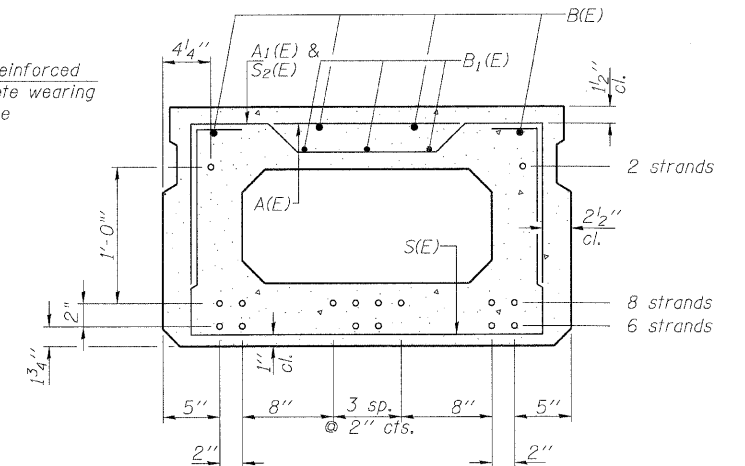

SECTION A-A

(Showing reinforcement and permissible strand locations)

Note: Place the number of strands specified in each row symmetrically about the centerline of beam in the permissible strand locations shown.

BAR LIST
ONE BEAM ONLY
(For information only)

Bar	No.	Size	Length	Shape
A(E)	14	#4	2'-7"	—
A1(E)	26	#4	2'-11"	~
B(E)	4	#5	42'-4"	—
B1(E)	3	#4	42'-4"	—
D(E)	16	#4	2'-9"	⌋
S(E)	62	#4	6'-5"	⌋
S1(E)	10	#4	4'-11"	⌋
S2(E)	52	#4	5'-2"	⌋
U(E)	8	#5	4'-0"	⌋
U1(E)	4	#4	5'-0"	⌋

Note: See sheet S-5 for additional details and Bill of Material.

* Exterior Beams only

21" x 36" PPC DECK BEAM
US 52 OVER FORKED CREEK
STA. 65+70
S.N. 099-0133

DESIGNED	B. Sauter
CHECKED	E. Mroczek
DRAWN	R. Danley
CHECKED	B. Sauter

PD-2136-0 5-16-08



Ciorba Group, Inc.
CONSULTING ENGINEERS
5507 North Cumberland Avenue, Suite 402 Chicago, Illinois 60656
Tel. 773.775.4009 Fax 773.775.4014 Email chicago@ciorba.com

SHEET NO. S-4	F.A.P R.T.E.	SECTION	COUNTY	TOTAL SHEETS	SHEET NO.
	852	18B	WILL	31	19
S-13 SHEETS	CONTRACT NO. 60D87				
FED. ROAD DIST. NO.		ILLINOIS	FED. AID PROJECT		