

STATE OF ILLINOIS
DEPARTMENT OF TRANSPORTATION

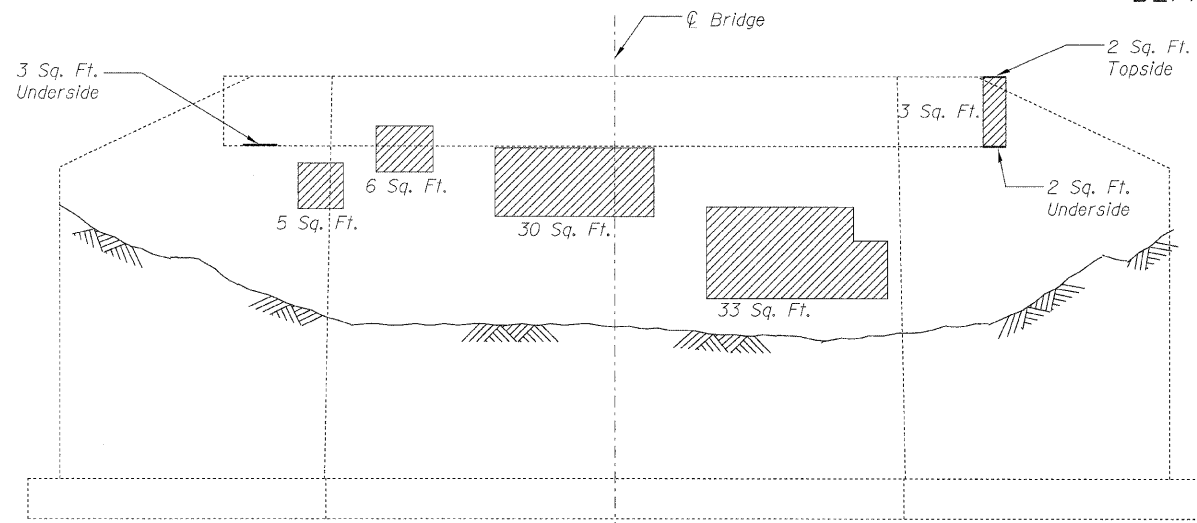

NORTH ABUTMENT ELEVATION

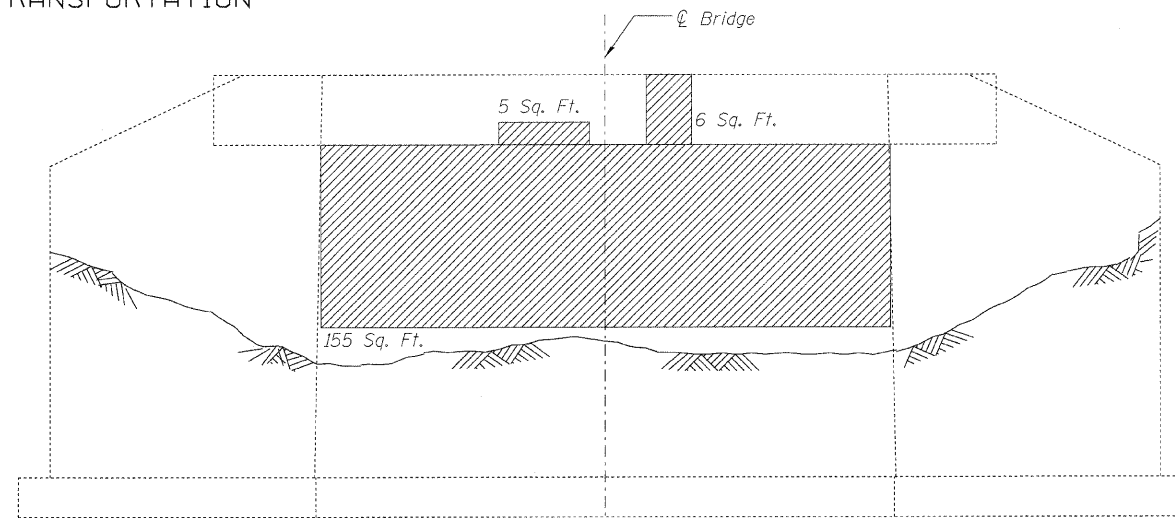

SOUTH ABUTMENT ELEVATION



NORTH ABUTMENT PLAN

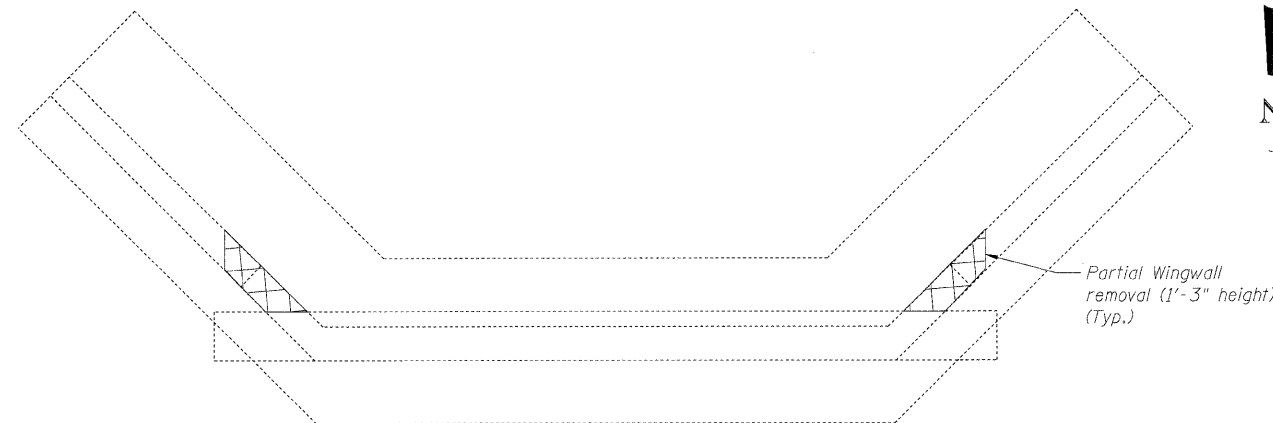

SOUTH ABUTMENT PLAN

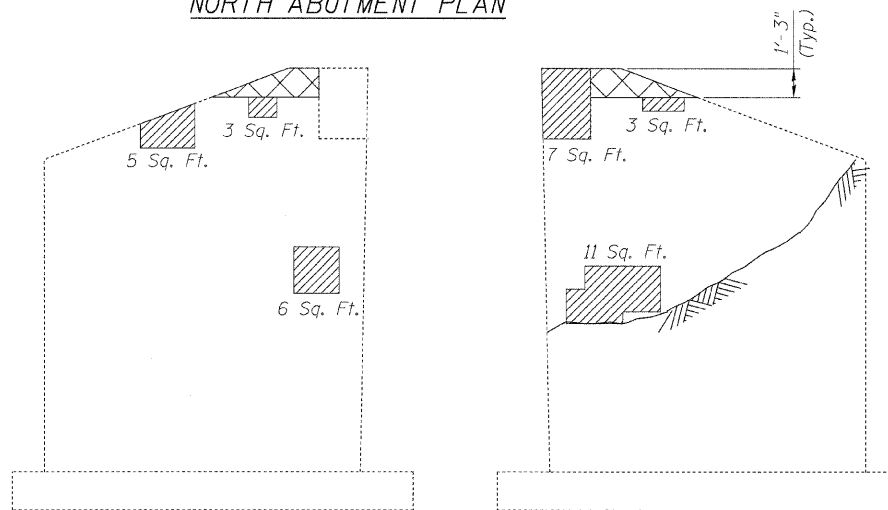

NW WINGWALL
(looking east)

NE WINGWALL
(looking west)

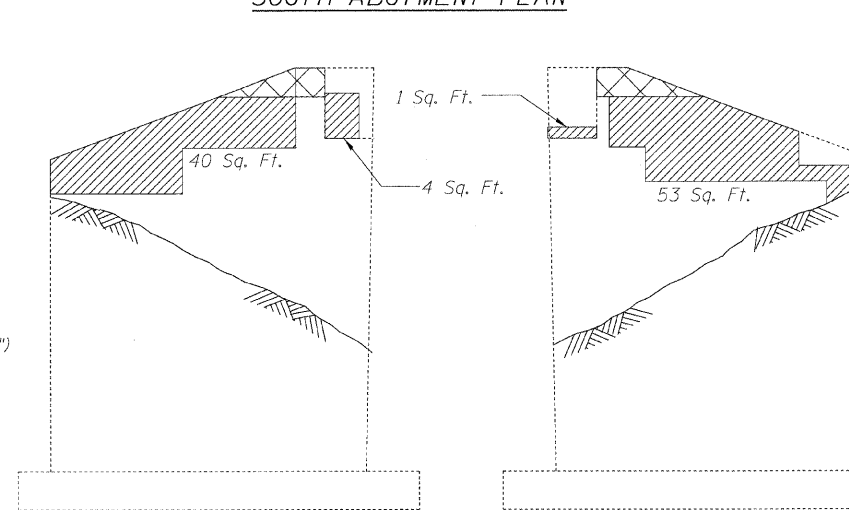

SE WINGWALL
(looking west)

SW WINGWALL
(looking east)

NOTE:
Repairs of the existing abutments shall include but not be limited to the areas shown. The actual areas to be determined by the engineer at the time of construction.

**NORTH AND SOUTH
ABUTMENT REPAIRS**
US 52 OVER FORKED CREEK
STA. 65+70
S.N. 099-0133

LEGEND
 Structural Repair of Concrete (≤ 5")
 Concrete Removal

BILL OF MATERIAL

Item	Unit	Quantity
Structural Repair of Concrete (Depth Equal to or Less than 5")	Sq. Ft.	385
Concrete Removal	Cu. Yd.	0.5

DESIGNED	B. Sauter
CHECKED	E. Mroczek
DRAWN	R. Danley
CHECKED	B. Sauter

Ciorba Group, Inc.
CONSULTING ENGINEERS
5507 North Cumberland Avenue, Suite 402 Chicago, Illinois 60656
Tel. 773.775.4009 Fax 773.775.4014 Email chicago@ciorba.com

SHEET NO. S-9	F.A.P. RTE.	SECTION	COUNTY	TOTAL SHEETS	SHEET NO.
	852	18B	WILL	31	24
S-13 SHEETS		CONTRACT NO. 60D87			
FED. ROAD DIST. NO.		ILLINOIS	FED. AID PROJECT		

7/8/2008

nt:\pro_1\3329_23\design\structural\road\sheet_3329_23.dwg Abutments.sht